

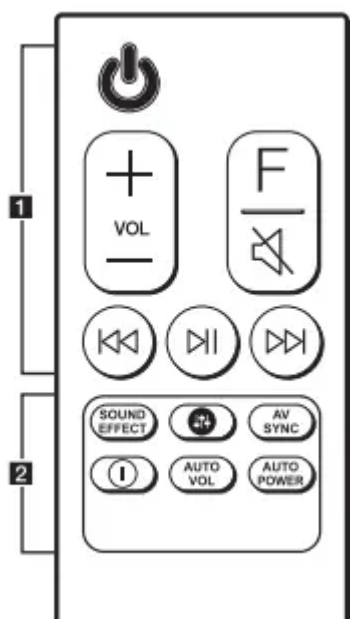

User manual Sound Bar



Replacement of Battery

Remove the battery cover on the rear of the remote control, and insert the battery with  and  matched correctly

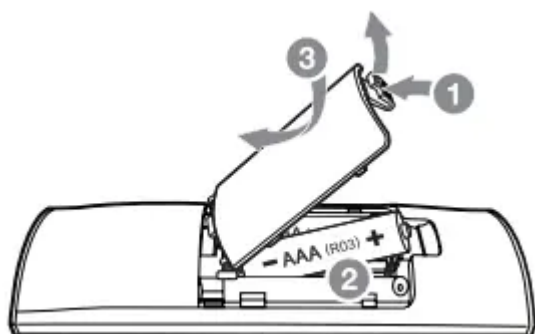

..... **1**

 (Standby) : Switches the unit ON or OFF.

VOL (Volume)  : Adjusts speaker volume.

F (Function) : Selects the function and the input source.

Input source / Function	Display
Wi-Fi	WI-FI
Optical ARC LG Sound Sync (Wired)	OPT/HDMI ARC
Bluetooth	BT
LG Sound Sync (Wireless)	LG TV
HDMI IN	HDMI IN
Portable	PORTABLE

 (Mute) : Mutes the sound.

 (Skip) : Skips Fast backward or Forward.

 (Play/Pause) : Starts playback. / Pauses playback.

..... **2**

SOUND EFFECT : Selects a sound effect mode.

 : Adjusts sound level of each speaker. (Page 37)

AV SYNC :

- Synchronizes the audio and video.
- Controls TV remote. (Page 33)

 :

- Displays the input source information.
- Displays the connected **Bluetooth** device name on **Bluetooth** function.

AUTO VOL :

- Turns on or off the AUTO VOLUME mode.
- Turns on or off the surround sound. (Page 17)

AUTO POWER :

- Turns on or off AUTO POWER function. (Page 35)
- Turns on or off the **Bluetooth** connection lock. (Page 33)

Front panel

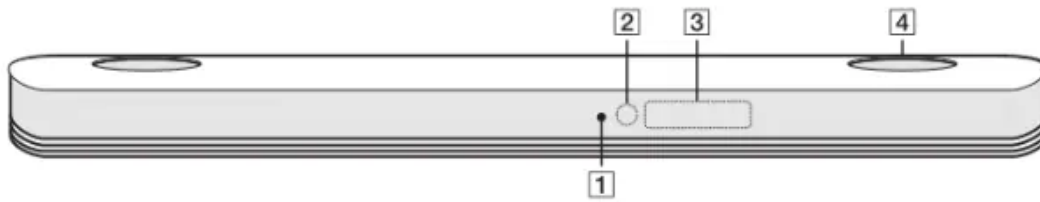

1 LED indicator

- Shows connection status.
- White (Blinking): Waiting for network connection on Wi-Fi function
- White (Staying on): Network connection is completed on Wi-Fi function or the other functions are selected.
- White (Dimmed): Standby mode with network connection.
- Red (Staying on): Standby mode without network connection.

2 Remote sensor

3 Display window

4 The buttons are located on the rear.

Rear panel

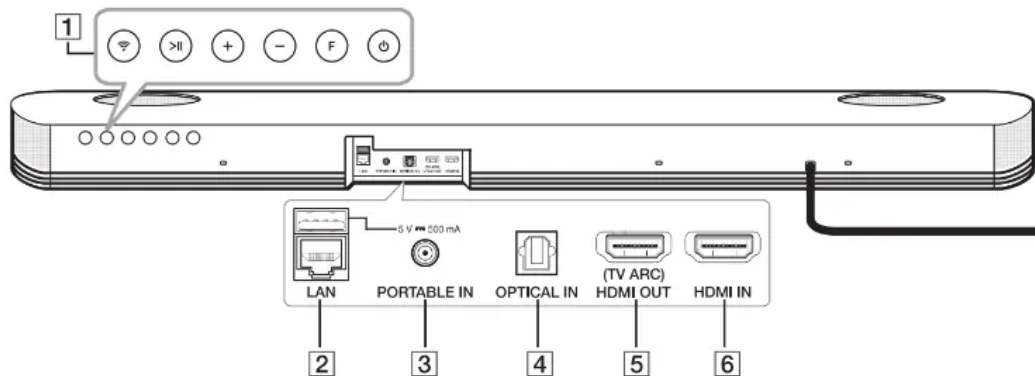

1 (Standby)

Switches the unit ON or OFF.

F (Function)

Selects the function and input source. (WI-FI, OPT/HDMI ARC, BT, LG TV, HDMI IN, PORTABLE)

 (Volume)

 (Play/Pause)

Starts playback. / Pauses playback

 (Wi-Fi)

Selects Wi-Fi function.

2 LAN port

Connect to a router.

3 PORTABLE IN connector

Connect portable device.

4 OPTICAL IN connector

Connect to an optical device.

5 HDMI OUT (TV ARC)

Connect to HDMI IN (ARC) on TV.

6 HDMI IN

Connect to device with HDMI OUT.

Connecting

Connecting to your TV

Please connect with this unit and TV using the optical digital cable or HDMI cable considering the state of the TV

Using an OPTICAL cable

1. Connect the OPTICAL IN jack on the back of the unit to OPTICAL OUT jack on the TV using an OPTICAL cable.

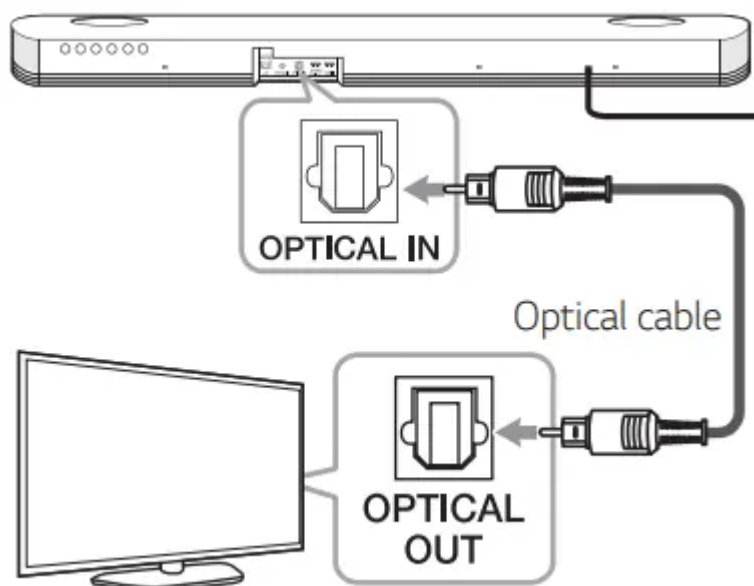

2. Select the input source to OPT/HDMI ARC by pressing F button on the remote or unit repeatedly.

You can see “OPTICAL” on the display window if connecting normally between this unit and your TV

Note

- Before connecting the optical cable, be sure to remove the protection plug cover if your cable has the cover
- You can enjoy the TV audio through the speakers of this unit. In the case of some TV models, you must select the external speaker option from the TV menu. (For details, reference your TV user manual.)
- Set up the sound output of TV to listen to the sound through this unit : TV setting menu → [Sound] → [TV Sound output] → [External speaker (Optical)]
- Details of TV setting menu vary depending on the manufacturers or models of your TV
- If this unit is connected by OPTICAL and ARC at the same time, the ARC signal is a high priority

Using an HDMI cable

If you connect this unit to a TV that supports HDMI CEC and ARC (Audio Return Channel), you can enjoy the TV audio through the speakers of this unit without connecting the optical cable.

1. Connect the HDMI OUT (TV ARC) jack on the back of the unit to ARC jack on the TV using an HDMI cable.

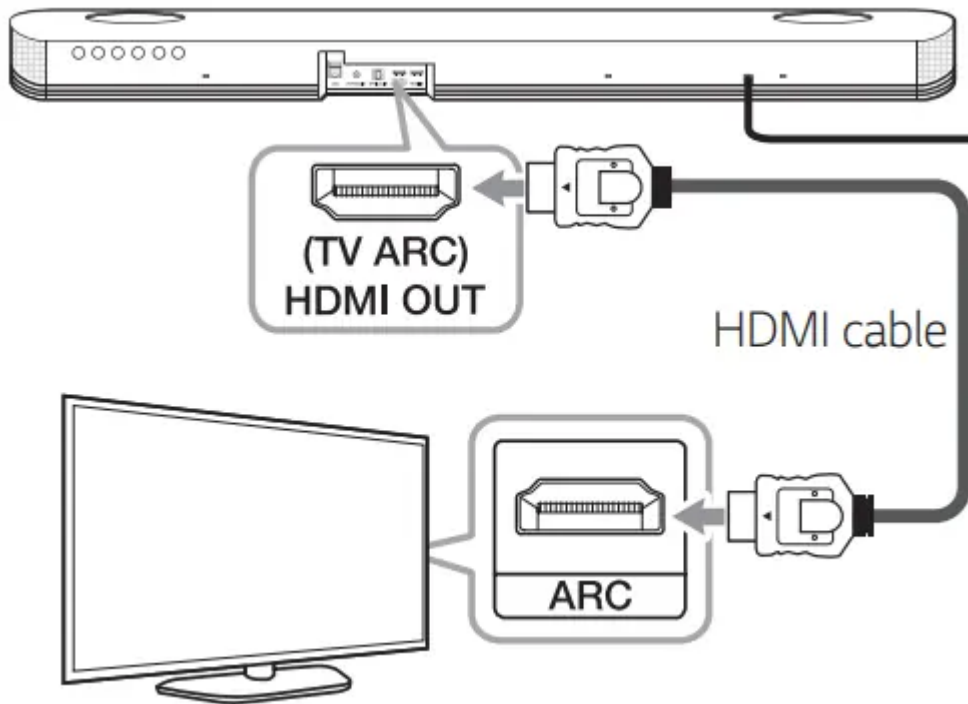

2. Select the input source to OPT/HDMI ARC by pressing F button on the remote or unit repeatedly

You can see “ARC” on the display window if connecting normally between this unit and your TV.

Note

You can enjoy the TV audio through the speakers of this unit. In the case of some TV models, you must select the external speaker option from the TV menu. (For details, reference your TV user manual.)

- Set up the sound output of TV to listen to the sound through this unit : TV setting menu → [Sound] → [TV Sound output] → [External speaker (HDMI ARC)]
- Details of TV setting menu vary depending on the manufacturers or models of your TV.
- Depending on your LG TV model, you may need to turn on the SIMPLINK function on your LG TV.
- When you return to ARC function from another function, you need to select the input source to OPT/HDMI ARC. Then this unit changes to ARC function automatically

ARC (Audio Return Channel) function

The ARC function enables an HDMI capable TV to send the audio stream to HDMI OUT of the unit.

To use this function :

- Your TV must support the HDMI-CEC and ARC function and the HDMI-CEC and ARC must be set to On.

- The setting method of HDMI-CEC and ARC may differ depending on the TV. For details about ARC function, refer to your TV manual.
- You must use the HDMI cable (Type A, High Speed HDMI™ cable with Ethernet).
- You must connect the HDMI OUT on the unit with HDMI IN of the TV that supports ARC function using an HDMI cable.
- You can connect only one Sound bar to TV compatible with ARC.

HDMI connection

You can enjoy the sound from the external device which is connected to HDMI IN jack on this unit.

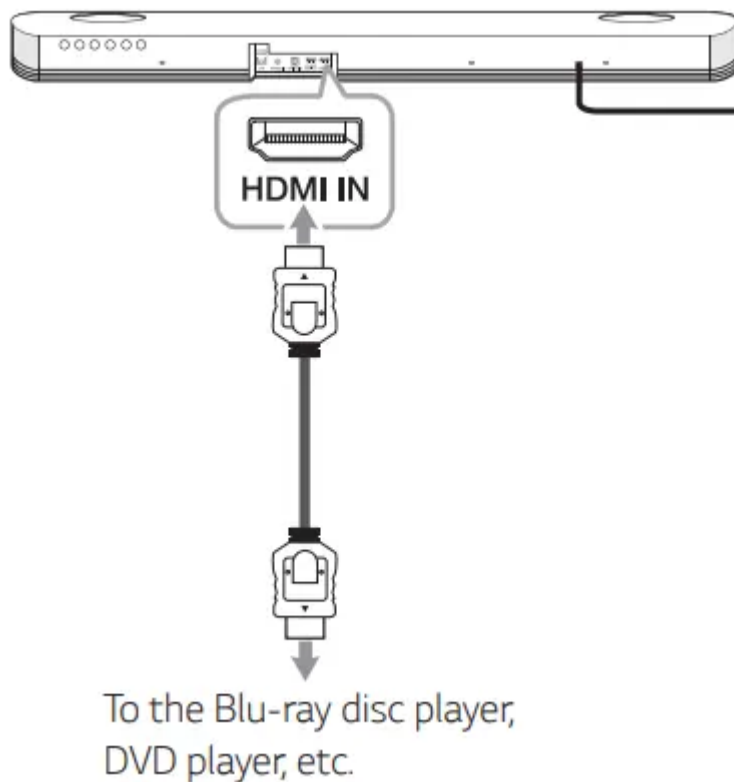

1. Connect HDMI IN jack on the back of the unit to HDMI OUT jack on the audio device such as Blu-ray disc player, DVD player, etc.
2. Set the input source to HDMI IN. Press repeatedly F on the remote control or F on the unit until the function is selected.

OPTICAL IN connection

Connect an optical output jack of external devices to the OPTICAL IN jack.

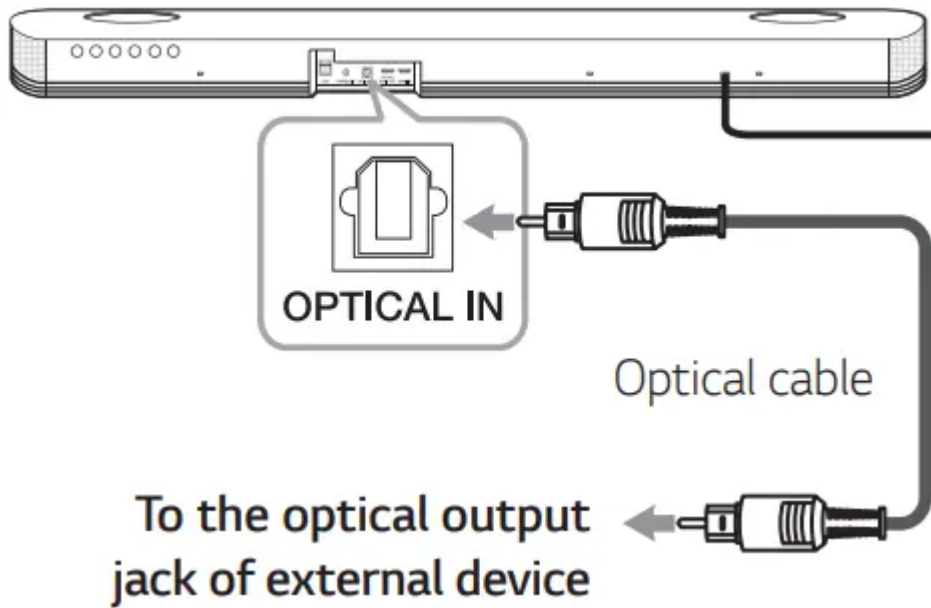

1. Connect the OPTICAL IN jack on the back of the unit to optical out jack of your external device.
2. Select the input source to OPT/HDMI ARC by pressing F button on the remote or unit repeatedly.

You can see “OPTICAL” on the display window if connecting normally between this unit and your device.

Note Before connecting the optical cable, be sure to remove the protection plug cover if your cable has the cover.

PORTABLE IN connection

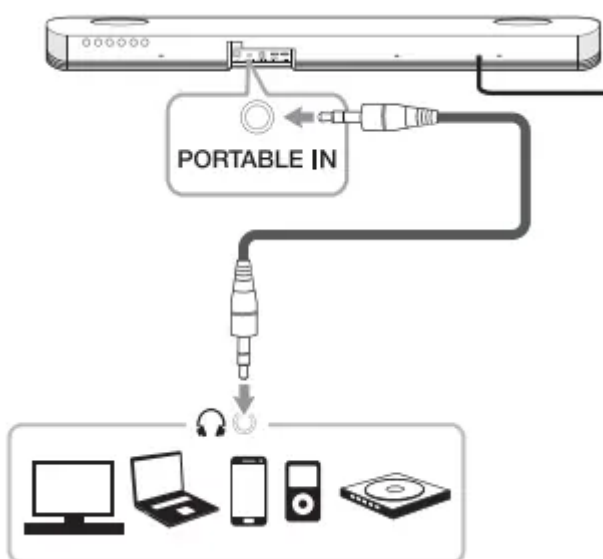

Listening to music from your portable player

The unit can be used to play the music from many types of portable players or external devices.

1. Connect the portable player to the PORTABLE IN connector of the unit.
2. Turn the power on by pressing  (Power).
3. Select the PORTABLE function by pressing F on the remote control or F on the unit until the function is selected.
4. Turn on the portable player or external device and start playing it.

Optional equipment connection

You can enjoy both sound and picture from the external device you connect.

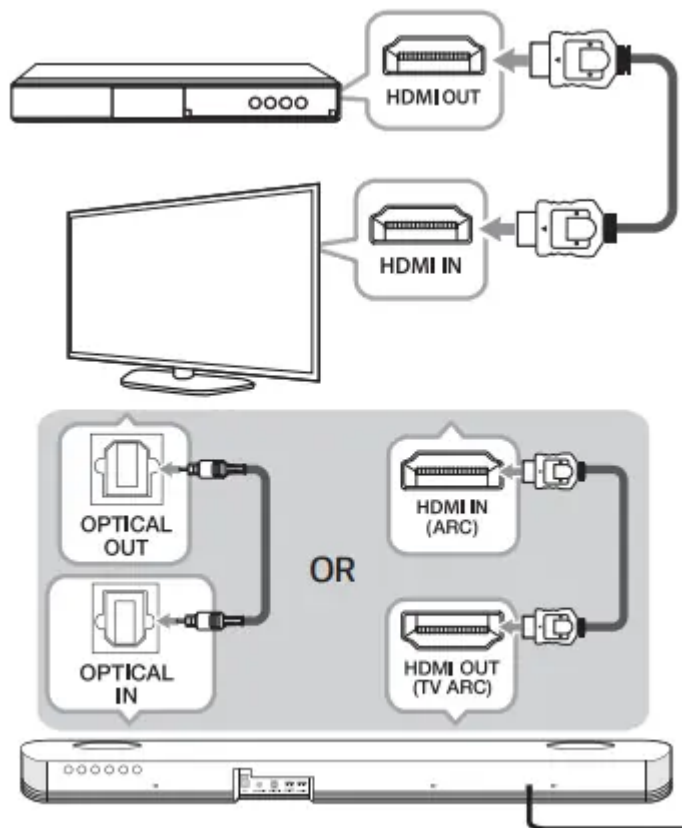

1. Connect HDMI IN jack of your TV to HDMI OUT jack on the external device such as Blu-ray disc player, DVD player, etc.
2. Connect the OPTICAL IN jack on the back of the unit to OPTICAL OUT jack on the TV using an OPTICAL cable.
Or connect the HDMI OUT (TV ARC) jack on the back of the unit to HDMI IN (ARC) jack on the TV using an HDMI cable.
3. Set the input source to OPT/HDMI ARC. Press repeatedly F on the remote control or F on the unit until the function is selected.

Note If the sound bar does not have sound or the video on TV is not smooth, the HDMI cable may be the problem. Refer to the HDMI cable checklist. (Page 24)

Network connection

You can enjoy various functions of this sound bar by connecting to network and your smart device with “LG Wi-Fi Speaker” app.

Choose the connection method considering your network environment.

Note

- In a network environment (Router, Internet and Internet Service Provider) that supports both IPv4 and IPv6, the network automatically connects to IPv4 or IPv6 when connecting to the network.
- You can check the each network status by selecting the settings of My Speakers ([Settings]>[IP Info.]) on the “LG Wi-Fi Speaker” app.

Wired connection

Using a wired connection provides the best performance, because the attached devices connect directly to the network without radio frequency interference.

Connect your sound bar to the home router using LAN cable.

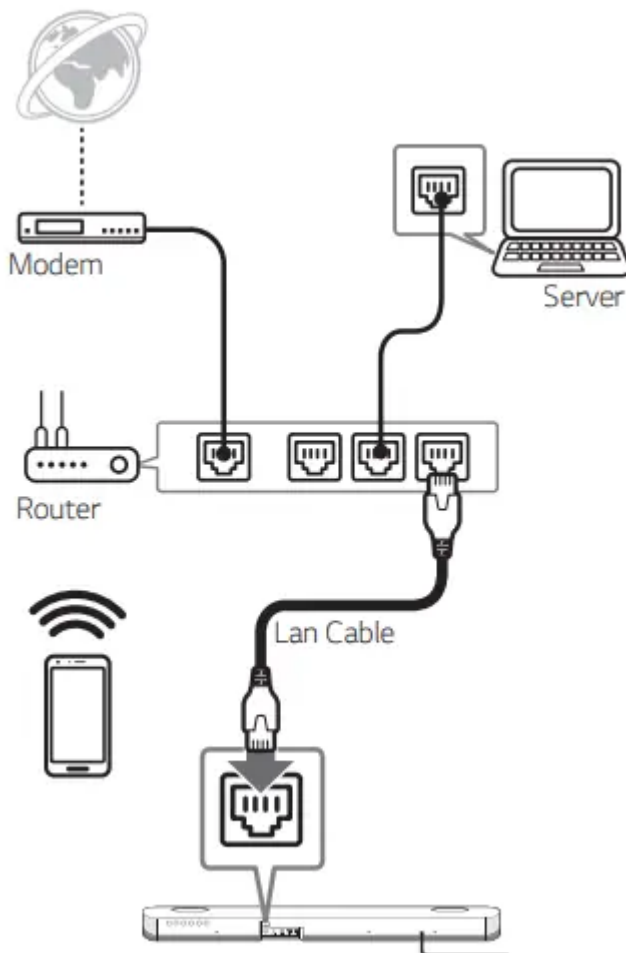

Wireless connection

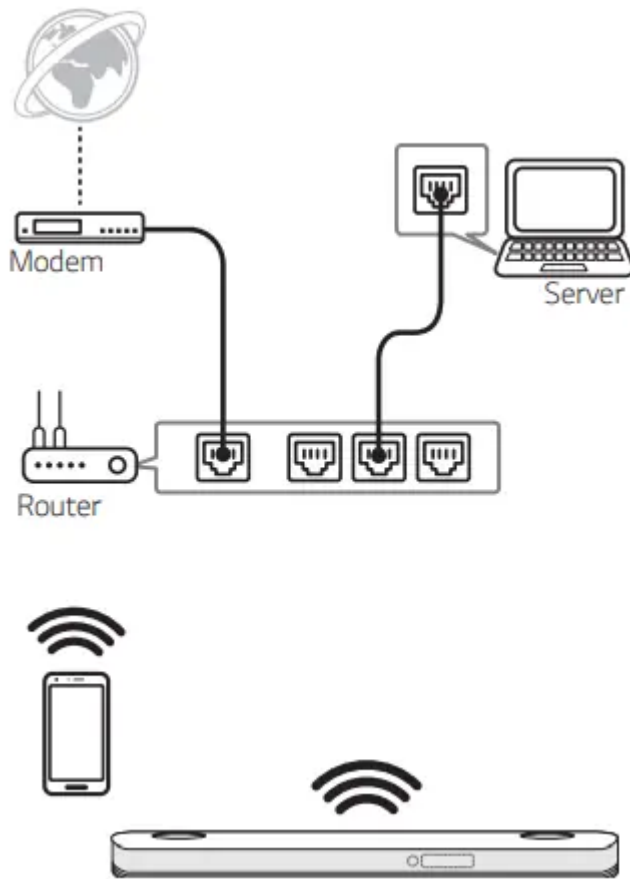

When the wired connection is unavailable between your sound bar and home router, you can connect it wirelessly.

The “LG Wi-Fi Speaker” app is required to connect the sound bar wirelessly to the network.

Download and install the “LG Wi-Fi Speaker” app on your smart device. Launch the application and follow the instructions on the screen of your smart device, so that you can connect the sound bar wirelessly

Operating

Using a Bluetooth Wireless Technology

About Bluetooth

Bluetooth is wireless communication technology for short range connection.

The sound may be interrupted when the connection interfered by the other electronic wave or you connect the Bluetooth in the other rooms.

Connecting individual devices under Bluetooth wireless technology does not incur any charges. A mobile phone with Bluetooth wireless technology can be operated via the Cascade if the connection was made via Bluetooth wireless technology.

- Available Devices : Smart phone, MP3, Notebook, etc.

- Version: 4.0
- Codec: SBC, AAC

Bluetooth profiles

In order to use Bluetooth wireless technology, devices must be able to interpret certain profiles. This speaker is compatible with following profile.

A2DP (Advanced Audio Distribution Profile)

Listening to Music of a Bluetooth Device

Before you start the pairing procedure, make sure that the Bluetooth feature on your smart device is turned on. Refer to your Bluetooth device's user guide. Once a pairing operation is performed, it does not need to be performed again.

1. Select the Bluetooth function by using F on the remote control or F on the unit until the function is selected. Appears "BT" and then "BT READY" in display window.
2. Operate the Bluetooth device and perform the pairing operation. When searching for this speaker on your Bluetooth device, a list of the devices found may appear in the Bluetooth device display depending on the type of Bluetooth device. Your speaker appears as "LG SK9Y (XX:XX)".
3. Select the "LG SK9Y (XX:XX)".

Note

- XX:XX means the last four digits of address. For example, if your unit has a MAC address such as 20:C3:8F:C9:31:55, you will see "LG SK9Y (31:55)" on your Bluetooth device.
 - Depending on the Bluetooth device type, some device have a different pairing way. Enter the PIN code (0000) as needed.
4. When this unit is successfully connected with your Bluetooth device, "PAIRED" → your device's name → "BT" appears on the display window.

Note

- If it is unavailable to display device name on the unit, "-" will be displayed.
 - To check the connected device's name, press  on the remote control. The connected Bluetooth device's name is displayed.
5. Listen to music.

To play music in your Bluetooth device, refer to your Bluetooth device's user guide.

According to your Bluetooth device's volume level, the volume level of Bluetooth will be adjusted.

Note

- When using Bluetooth technology, you have to make a connection between the unit and the Bluetooth device as close as possible and keep the distance.

However it may not work well in the case below :

- There is an obstacle between the unit and the Bluetooth device.
- There is a device using same frequency with Bluetooth technology such as a medical equipment, a microwave or a wireless LAN device.

Note

- This unit supports Bluetooth auto pairing. However it does not operate in the case below:
 - When you restart this unit.
 - When you disconnect this unit by yourself.
 - When you disconnect this unit on the connected Bluetooth device.
- The sound may be interrupted when the connection is interfered with by the some other electronic wave.
- You cannot control the Bluetooth device with this unit.
- Pairing is limited to “One” Bluetooth device. Multi-Pairing is not supported.
- Depending on the type of the device, you may not be able to use the Bluetooth function.
- You can enjoy using Bluetooth when using Phone, MP3, Notebook, etc..
- The more distance between the unit and the Bluetooth device, the lower the sound quality becomes.
- The Bluetooth connection will be disconnected when the unit is turned off or the Bluetooth device gets too far from the unit.
- If the Bluetooth connection is disconnected, connect the Bluetooth device again.
- When a Bluetooth device is not connected, “BT READY” appears on the display window.
- If you set the WI-FI function in the state of unconnected network, Bluetooth and Wireless TV Sound Sync may not be connected.
- If you change to another function after connecting Bluetooth device, Bluetooth connection will be disconnected. And you return to Bluetooth function, Bluetooth connection will be connected automatically.

Bluetooth connection lock (BT LOCK)

You can limit Bluetooth connection to only BT (Bluetooth) and LG TV function to prevent unintended Bluetooth connection.

To turn on this function, press and hold AUTO POWER on the remote control for about 2 seconds in BT (Bluetooth) function and press it once again while “OFF - BT LOCK” is scrolled. Then you can limit Bluetooth connection.

To turn off this function, press and hold AUTO POWER on the remote control for about 2 seconds in BT (Bluetooth) function and press it once again while “ON - BT LOCK” is scrolled.

Note Even if you set up BT LOCK function to On, this sound bar turns on by Auto Power function. Turn off Auto Power function to prevent it. (Page 35)

AUTO POWER On/Off

This sound bar automatically turns on and off by an input source : Optical, LG TV, Bluetooth or “LG Wi-Fi Speaker” app.

This function turns on or off each time you press AUTO POWER.

Turning on

Turning on automatically by this function is supported only on network standby mode except an optical signal. Check dimmed white LED on the unit.

When you turn on your TV or an external device connected to this unit, this unit recognizes the input signal and selects the suitable function. You can hear the sound from your device.

If you try to connect your Bluetooth device, this unit turns on and the unit will be connected to your Bluetooth device.

When you run the “LG Wi-Fi Speaker” app and play music on your smart device that has already been paired, the sound bar is turned on to Wi-Fi function and you can listen to the music through the sound bar.

Turning off

When the TV is off, this sound bar switches to the standby mode.

Note

- After the unit is turned on by AUTO POWER function, it will be automatically turned off if there is no signal for a certain period of time from the TV connected by LG Sound Sync (Optical/Wireless).
- After the unit is turned on by AUTO POWER function, it will be automatically turned off if there is no signal for a certain period of time from the external device.
- If you turned off the unit directly, it cannot be turned on automatically by AUTO POWER function. However the unit can be turned on by AUTO POWER function when optical signal comes in after 5 seconds of no signal.
- Depending on the connected device, this function may not operate.

- If you disconnect Bluetooth connection by this unit, some Bluetooth devices try to connect to the unit continually. Therefore it is recommended to disconnect the connection before turning off the unit.
- When you turn on this unit for the first time, status of Auto Power function is turned on.
- To use this function, the main unit must be registered in paired devices list of Bluetooth device.
- You can set the AUTO POWER function only when this unit is turned on.

Sound adjustment

Setting sound effect

This system has a number of pre-set surround sound fields. You can select a desired sound mode by using SOUND EFFECT.

The displayed items for the equalizer may be different depending on sound sources and effects.

On Display	Description
ASC (Adaptive Sound Control)	Analyzes the property of the input sound and provides the sound optimized for the content in real time.
BASS BLAST or BASS BLAST+	Reinforces the bass and powerful sound.
STANDARD	You can enjoy optimized sound.
MOVIE	You can enjoy more immersive and cinematic surround sound.
MUSIC	You can enjoy more good sound for music source.

Note

- Sound effect order may be different depending on the regional option.
- In some of the sound effect modes, there will be no sound or low sound from some of the speakers. It depends on the mode of sound and the source of audio, it is not a defect.
- You may need to reset the sound effect mode, after switching the input, sometimes even after the sound file changed.
- When a source of Dolby Atmos is inputted, sound effect will be changed to DOLBY ATMOS automatically.

In this state, even though you press the buttons, such as SOUND EFFECT and AUTO VOLUME, this unit does not respond. And you can see only “NOT SUPPORTED” on the display window.

Adjust volume level automatically



This unit supports Auto volume function that automatically adjusts the volume level.

When the output sound is too loud or too low, press AUTO VOL on the remote control. So you can enjoy the sound with appropriate levels.

To cancel this function, press the button again while “ON-AUTO VOLUME” is displayed.

Adjust Sound level

You can adjust the sound level of each speaker : Sub Woofer, Treble, Bass, Overhead Volume Control , Rear

1. Press  button repeatedly to select the speaker you want to adjust.
2. Press VOL  to adjust the sound level.

Speaker	Display	Range
Sub Woofer	SUBWF	-15 ~ 6
Treble	TREBLE	-5 ~ 5
Bass	BASS	-5 ~ 5
Overhead Volume Control	OVC	-6 ~ 6
Rear	REAR	-6 ~ 6

Note Adjusting rear speakers level is applied only when the rear speakers are connected.

Troubleshooting

General



Symptoms	Cause & Solution
The unit does not work properly.	<ul style="list-style-type: none"> • Turn off the power of this unit and the connected external device (TV Woofer, DVD-player Amplifier etc.) and turn them on again. • Disconnect the power cord of this unit and the connected external device (TV Woofer, DVD-player Amplifier etc.) and then try connecting again. • Previous setting may not be saved when device power is shut off.
The power does not turn on.	<p>Is the power cord plugged into the outlet?</p> <ul style="list-style-type: none"> • Connect the power plug to the outlet.
Sound is not produced.	<p>Is the volume set to minimum?</p> <ul style="list-style-type: none"> • Adjust the volume. • When you are using connection with a external device (set top box, Bluetooth device etc.), adjust volume level of the device. <p>Is the mute function activated?</p> <ul style="list-style-type: none"> • Press  or adjust the volume level to cancel the mute function. <p>Is the function selected properly?</p> <ul style="list-style-type: none"> • Check the input source and select the correct input source.
No woofer sound	<p>Is the subwoofer plugged in?</p> <ul style="list-style-type: none"> • Plug the power cord of subwoofer into the wall outlet securely. <p>Is pairing between the unit and the subwoofer disconnected?</p> <ul style="list-style-type: none"> • Connect the unit and the subwoofer (Page 14)

<p>The remote control does not work properly.</p>	<p>Is the remote control too far from the unit?</p> <ul style="list-style-type: none"> • Operate the remote control within about 7 m (23 ft). <p>Is there an obstacle in the path of the remote control and the unit?</p> <ul style="list-style-type: none"> • Remove the obstacle. <p>Are the batteries in the remote control exhausted?</p> <ul style="list-style-type: none"> • Replace the batteries with new one.
<p>The AUTO POWER function does not work.</p>	<ul style="list-style-type: none"> • Check connection of the external device such as TV DVD/Blu-Ray player or Bluetooth device. • Check the state of SIMPLINK on your LG TV and turn off SIMPLINK. • Depending on the connected device, this function may not operate.
<p>LG Sound Sync does not work.</p>	<ul style="list-style-type: none"> • Check whether your LG TV supports LG Sound Sync. • Check connection of LG Sound Sync. • Check sound setting of your TV and this unit.
<p>When you feel the output sound of the unit is low.</p>	<p>Check the details below and adjust the unit according to them.</p> <ul style="list-style-type: none"> • Switch the state of DRC function to [OFF] by using "LG Wi-Fi Speaker"! • With the sound bar connected with TV change the AUDIO DIGITAL OUT setting on TV Setup Menu from [PCM] to [AUTO] or [BITSTREAM]. • With the sound bar connected with Player change the AUDIO DIGITAL OUT setting on Player Setup Menu from [PCM] to [PRIMARY PASS-THROUGH] or [BITSTREAM]. • Change Audio DRC setting on connected device setup menu to [OFF] state. • Make sure Night Mode is not On. Turn [OFF] Night Mode.

The unit does not connect with Bluetooth device.	<ul style="list-style-type: none"> • Turn off the Bluetooth connection lock function. (Page 33)
--	--

Network

Symptoms	Cause & Solution
Cannot connect the speaker to your home network.	The wireless communication may be interrupted from household devices that are using radio frequencies. Move the speaker away from them.
Media servers are not displayed on the device list.	<ul style="list-style-type: none"> • The firewall or anti-virus software on your media server is running. Turn off the firewall or anti-virus software running on your media server. • Make sure that the speaker is connected to the same network that your media server is connected.
"LG Wi-Fi Speaker" doesn't work properly	<p>Is the "LG Wi-Fi Speaker" plugged in?</p> <ul style="list-style-type: none"> • Plug in the "LG Wi-Fi Speaker". <p>Is the LAN cable connected to the wireless router and the "LG Wi-Fi Speaker" properly?</p> <ul style="list-style-type: none"> • Connect the LAN cable to the LAN port on the back of the "LG Wi-Fi Speaker" and to your wireless router <p>If you restart the router?</p> <ul style="list-style-type: none"> • You need to turn the speaker's power off and on again. <p>If you install new router.</p> <ul style="list-style-type: none"> • You need to perform a factory set and setup the network connection for speaker.

Application

Symptoms	Cause & Solution
"LG Wi-Fi Speaker" app doesn't work properly.	<p data-bbox="754 387 1331 421">Does an error occur when accessing the app?</p> <ul data-bbox="754 450 1445 734" style="list-style-type: none"><li data-bbox="754 450 1445 528">• Make sure that your smart device is compatible with the app.<li data-bbox="754 557 1445 636">• Make sure that the "LG Wi-Fi Speaker" app is the latest version.<li data-bbox="754 665 1445 734">• Make sure that the speaker's front LED turns from red to white.



NOTES to use wireless

Symptoms	Cause & Solution
This device may have wireless interference.	<ul style="list-style-type: none">• Wireless may not operate normally in weak signal area.• Please install the device close enough to wireless subwoofer• Do not install the device on metal furniture for optimum performance.
Bluetooth device may malfunction or make noise in the following cases.	<ul style="list-style-type: none">• When any part of your body contact the transceiver of the Bluetooth device or sound bar.• When there is an obstacle or wall or the device is installed in a secluded spot.• When there is a device (a wireless LAN, a medical equipment or a microwave) using same frequency make the distance between the products as far away as possible each other• When connecting the device to the Bluetooth device, make the distance between the products as close as possible each other.• When the device gets too far from the Bluetooth device, the connection is disconnected and also malfunction may occur

NOTES to release Demo mode

Symptoms	Cause & Solution
Can not change input source with F button such as BT (Bluetooth), HDMI etc. and only [DEMO] indication is showing in the front display.	Unplug the power cord and plug it in again. If that doesn't work, press and hold  on the sound bar button until you hear the beep sound once. You can see "RESET" on the display window.
Remote Control does not work. (No response)	

Warning

This content is compiled from multiple sources and is provided for reference purposes only. It may not be complete or fully applicable to all situations. If you are unable to resolve your issue, please contact the product manufacturer or an authorized service provider for official support.