

## Getting Started

### Parts

Picture shows a double oven. Your appliance may vary slightly.



1. Control Panel
2. Door Gasket
3. Convection Fan, some models
4. Door Hinge
5. Oven Vent
6. Door Latch
7. Rack Position Guides with 6 rack positions
8. Oven Bottom

### Cooling Fan

The cooling fan runs during all cooking modes. The fan can be heard when it is running, and warm air may be felt as it is released from the oven vent. The fan may also run after the oven is off.

### Oven Vent

The oven vent is located below the control panel. Warm air may be released from the vent before, during and after cooking. It is normal to see steam escaping from the vent, and condensation may collect in this area. This area may be warm when the oven is in use. Do not block the vent, since it is important for air circulation.

### Oven Bottom

The oven bottom conceals the lower heating element. As a result the element is protected from damage and spills.



#### Note:

Do not place food directly on the oven bottom.

### CAUTION

Do not use aluminum foil or protective liners to line any part of the appliance, especially the oven bottom. Installation of these liners may result in a risk of electric shock or fire.

## Accessories

	<p><b>Flat Rack</b></p> <p>Do not clean in the Self Clean oven.</p>
	<p><b>Broiling Pan (available via eShop)</b></p> <p>Pan: #00449757</p> <p>Grill(top):#00449756</p>

### Inserting Racks

### CAUTION

To avoid burns, place oven racks in desired positions before turning oven on. Always use oven mitts when the oven is warm. If a rack must be moved while the oven is hot, do not let oven mitts contact hot heating elements.

Use caution when removing an oven rack from the lowest rack position to avoid contact with the hot oven door.

To avoid possible injury or damage to the appliance, ensure flat rack is installed exactly per installation instructions and not backwards or upside down.

### Flat Rack

The rack is designed with a stop so it will stop before coming completely out of the oven and not tilt.

#### To insert the flat rack into the oven:

**Note:** Avoid pushing the rack back forcefully, impacting the rear of the oven cavity. This may cause risk of damage to porcelain coating or to glass covers over light fixtures.

1. Grasp rack firmly on both sides.
2. Insert rack (see picture).

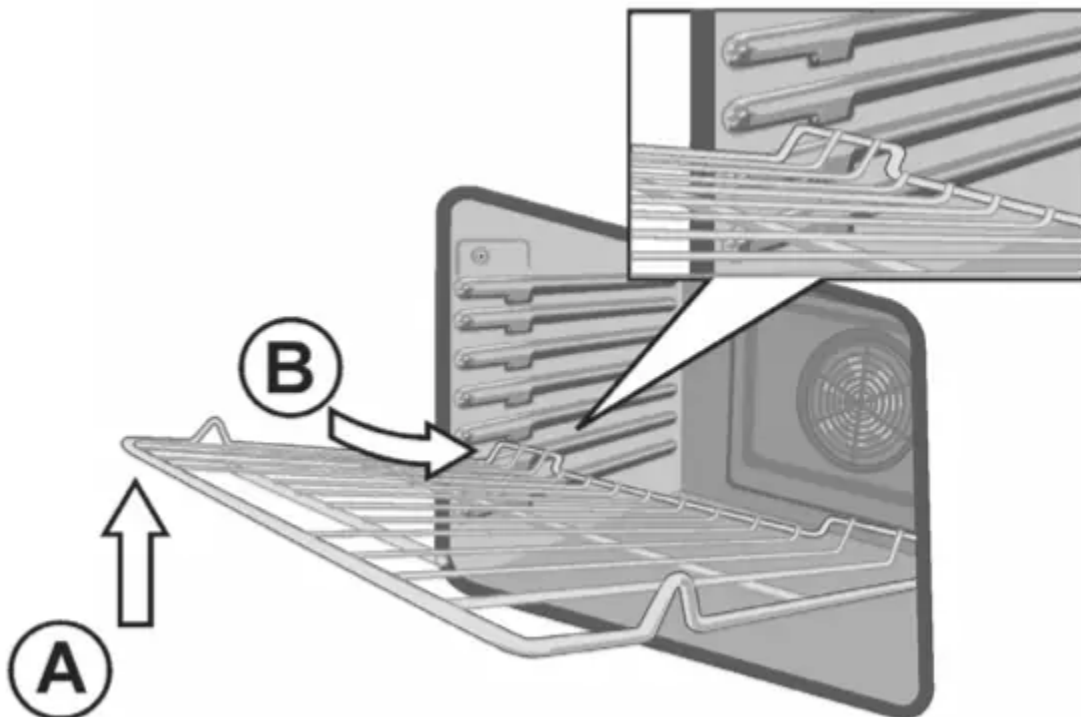

3. Tilt rack up (A) to allow the upwardly sloped rear of the rack to slide under the stop molded into the front portion of the rack guide above.

4. When the back of the rack is past this stop, lower the front of the rack to a horizontal position (B) and push it the rest of the way in. The rack should be straight and flat, not crooked.

**To remove the flat rack from the oven:**

1. Grasp rack firmly on both sides and pull rack toward you.
2. When the stop is reached, tilt rack up so that the upwardly sloped back of the rack can pass under the stop. Pull the rack the rest of the way out.

## Control

### Double Convection Oven Control Panel



### Double Non-Convection Oven Control Panel



### Single Convection Oven Control Panel



### Single Non-Convection Oven Control Panel



1. Upper Oven Mode Dial



2. Oven Mode Dial
3. Display, 8 buttons
4. Display, 6 buttons
5. Lower Oven Mode Dial
6. Temperature Settings Dial

## Buttons

**Note:** You only need to press lightly on the buttons to operate them. The buttons will not have any affect if you press several of them at once, such as when cleaning the control panel by wiping across it.

	Switches to the upper oven in double oven models. Press before changing settings for the upper oven (double oven models only).
	Switches to the lower oven in double oven models. Press before changing settings for the lower oven (double oven models only).
	Turns the oven light off or on. Does not operate when the oven is in Self Clean mode.
	Clears the kitchen timer when editing or when finished.
	Sets and displays the kitchen timers (double ovens, Timer for single ovens). The timers do not control the oven activities.
	Increases the displayed value when pressed.
	Decreases the displayed value when pressed.
	Enters the clock set mode.

## Operation

### About the Appliance

Your new oven combines premium cooking results and simple operation.

The oven design has been optimized to improve heat distribution in the oven cavity. The result is even browning, shorter cooking times and lower energy consumption.

Thanks to the Self Clean mode, hours of scrubbing into the darkest corners of the oven is a thing of the past. The oven burns off soil simply and easily. All that is left to do is to remove a few ashes from the oven when Self Clean is done.

Clear labeling of the buttons and knobs make operating the oven very easy. This manual includes all instructions for operating the oven.

Please call us if you ever have any questions. Our telephone number is located at the beginning of this manual. We welcome your comments and suggestions!

## Before Using the Oven for the First Time

- Oven must be properly installed by a qualified technician before use.
- Remove all packing materials from inside and outside the oven.
- While cool, wipe with a clean, damp cloth and dry.
- There may be a slight odor during first uses; this is normal and will disappear.
- Optimum cooking results depend on proper bakeware being used.
- Read and understand all safety precautions and Use and Care Manual information prior to operating.

## Oven Features

### Setting the Clock

To set the clock:



1. Turn the Cooking Mode dial to "Off".
2. Press Clock. The clock will be displayed. The hours will blink to indicate the value can be changed.
3. Use the + or - buttons to set the hour.
4. Press Clock again to set the minutes. The minutes will blink to indicate the value can be changed.

5. Use the + or - buttons to set the minutes.

**Note:** Pressing and holding the + or - buttons will cause the minutes to change more rapidly.

If no change is entered for 3 seconds the time displayed will be saved.

## Setting the Cooking Mode and Temperature

### Setting the Cooking Mode and temperature for Double Ovens

#### Double Oven Control Panel

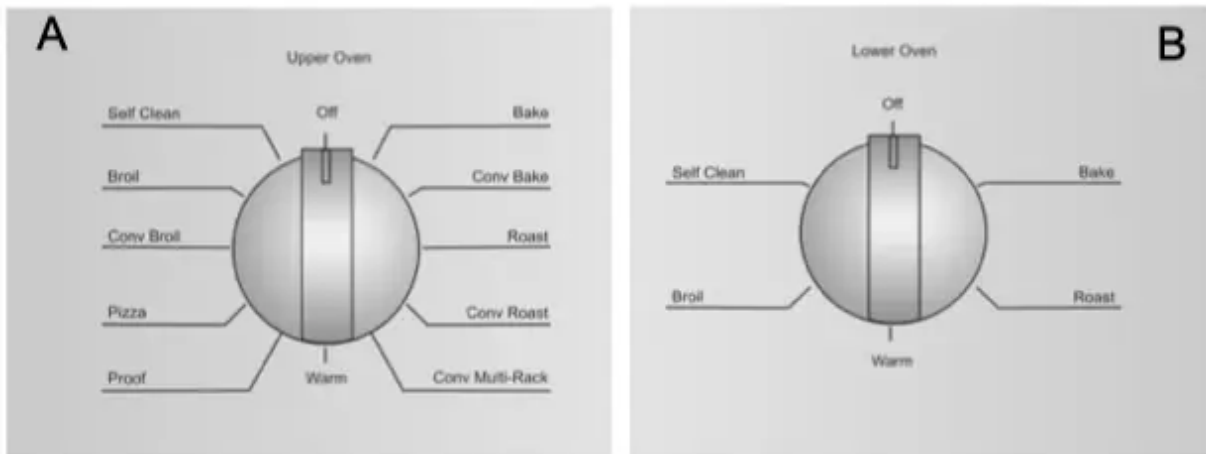

1. Turn the Upper (A) or Lower (B) Oven Mode dial to the preferred cooking mode.

2. The display shows the default temperature for the mode at the left of the current time.

3. Press the + or - buttons to change the temperature.

4. When the desired temperature is unchanged for 3 seconds, or if the Timer button is pressed, the cooking mode starts and the timer opens in timer edit mode. (Note: When the timer is set, it counts down to 0:00 but does not turn off the oven.)

5. Preheating will display in red underneath the selected temperature until the temperature is reached. During preheat the selected temperature is displayed, not the current oven cavity temperature.

6. If a timer is set, the display will show the selected temperature for 3 seconds and will then display the timer countdown.

#### **Note:**

- The cooking mode can be changed at any time during operation.
- For double oven models, the upper or lower oven must be selected before the temperature can be changed. Press Upper Oven or Lower Oven to select an oven.

### Setting the Cooking Mode and temperature for Single Ovens

#### Single Convection Oven Control Panel

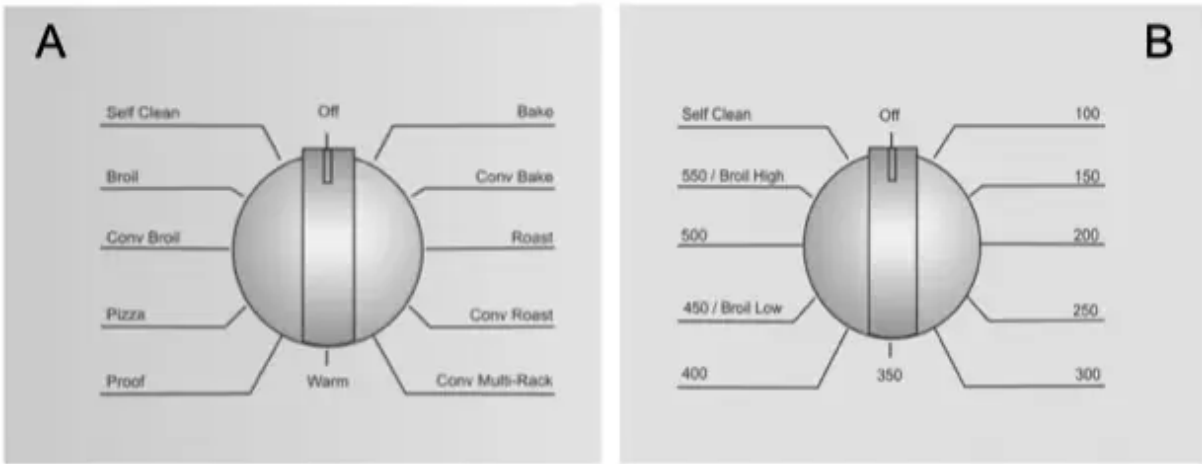

1. Turn the Oven Mode Dial (A) to the preferred cooking mode.
2. Turn the Temperature Settings Dial (B) to change the temperature.
3. Preheating will display in red underneath the selected temperature.

**Note:**

- The cooking mode can be changed at any time during operation.
- The Temperature Settings Dial can be turned to the marked temperatures or in between to select a specific temperature (i.e.: 325° would be halfway between 300° and 350°.)

**Heating Time Limitation**

The maximum heating time is limited. If you forget to turn off the oven, it turns off automatically after a set period of time.

The maximum time for Sabbath mode is 74 hours; for all other cooking modes the maximum allowed time is 24 hours.

Temperature in °F	Temperature in °C.	Max. time allowed without activity.
100–200	30–120	24 hours
201–550	121–300	12 hours

**Timer**

Setting the timer:



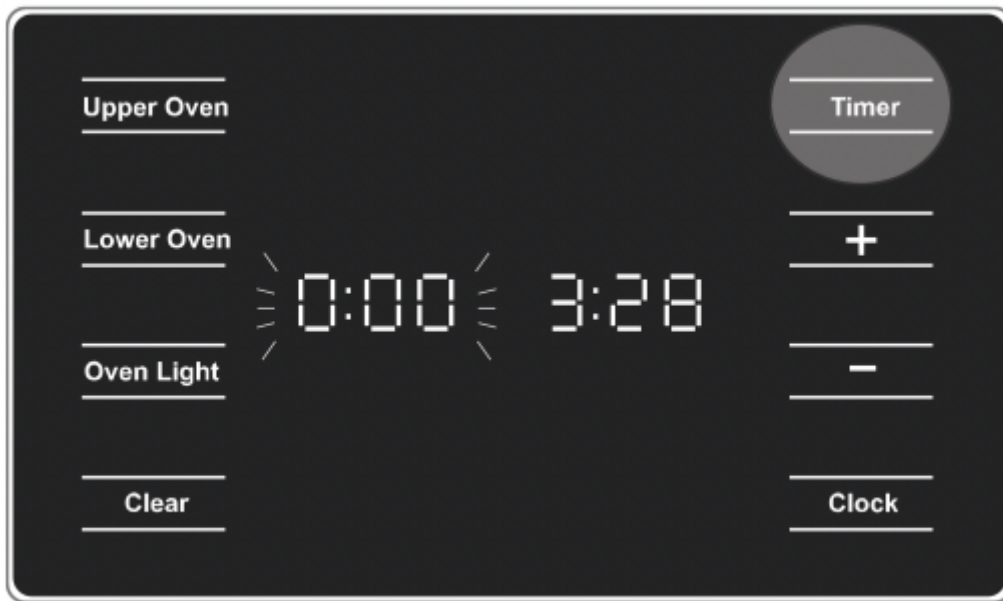

1. Press Timers. If no other timer is running, "00:00" appears in edit mode and flashes.
2. Press the + button to set the amount of time. Holding the button down increases the timer value more quickly.
3. Press Timers again to store the timer value set and begin the timer countdown.

The timer starts.

When the timer reaches 0:00 the timer display blinks and an alarm tone sounds every 10 seconds for two minutes.

4. Press Clear or open the oven door to cancel a running timer and terminate the beep signal.

**Note:**

- The timer can be set for a maximum of 99:59 hours (hours:minutes). When the timer reaches 1 minute remaining, the count changes to seconds and counts down from :59 to :00.
- The timer does not change when other settings are changed.
- A timer may not be set during a Self Clean operation.
- A second timer can be set (double ovens only) after the first timer has started. Press Timers twice to enter the editing mode for the second timer.

**Sabbath Mode**

The Sabbath Mode enables those of particular faiths to use their ovens on the Sabbath. Sabbath Mode can be entered at any time during a Bake cycle only.

To set the Sabbath Mode:

1. Turn the Cooking Mode Dial to Bake.



2. Set the temperature to a value within the Sabbath Mode temperature range (100° to 450° F).

If the temperature set is outside this range, and the Timer button is held for 3 seconds, an error tone sounds.

3. Press and hold the Timer (or Timers) button for three seconds.

SAb appears in the display for 3 seconds.

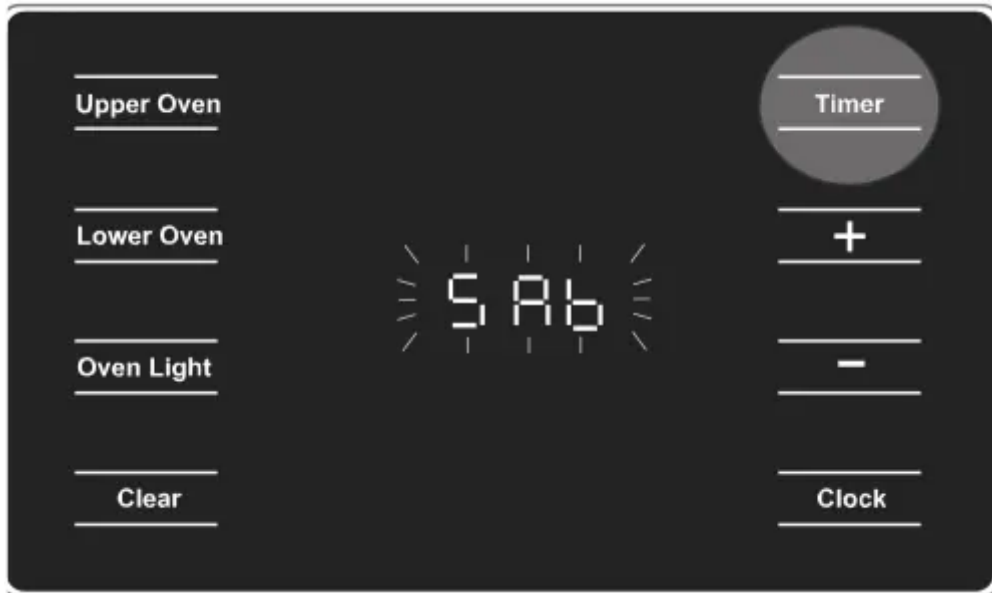

4. 74:00 flashes in the display. 74 hours is the maximum number of hours that can be set for Sabbath Mode.



5. Press + or - to edit Sabbath cook time by 30 minute increments. Holding the button more than 1 seconds causes the displayed value to change 30 minutes each 1/2 second until the button is released. The maximum time allowed to be set is 74 hours.

6. If no change is made for 3 seconds, or if Timer is pressed, Sabbath mode begins and the timer counts down in 1 minute increments until it reaches :00, then displays SAb. The heating mode ends, but the oven stays in Sabbath Mode.

**Note:**

- Pressing any of the buttons while the oven is in Sabbath mode will have no effect. Turn the Cooking Mode Dial to Off to cancel Sabbath Mode.
- Changing the Oven Mode Selector to any other mode will end Sabbath Mode.
- In double oven models, Sabbath Mode is available for both ovens at the same time. Sabbath Mode can only be set for one oven at a time.
- The allowed temperature in Sabbath Mode is 100° to 450° F.
- The period of time for Sabbath Mode to run can be set between 0:01 and 74:00 hours.
- If the oven light is on when Sabbath Mode is set, the light remains on. If it is off when Sabbath Mode is set, the light remains off.

**Settings**

The Settings menu is used to customize the oven settings.

To make changes to Settings:

The oven must be turned off with no timer running in order to access the "Settings Menu".



1. To Access the Settings Menu:

- Single Ovens: Press Clock and + for two seconds
- Double Ovens: Press Upper Oven and Timer The first menu item, S1, appears in the display.

2. Press Clock to move through the settings list.



3. Press + or - to change the setting.

4. Press Clock to move to the next setting option. The next menu item, S2, appears in the display.

Always set the values as described in steps 2 and 3. Press Clear to leave the menu.

### Settings Menu Options

Menu item	Description	Settings (Default)
S1: Clock Mode	12-hour or 24-hour display mode; 1=12hr, 2 =24hr	1=12hr
S2: Temperature Unit	F = Fahrenheit, 1=F C = Celsius, 2=C	1=F
S3: Sound with each key press	Button sound: Yes or No: 1=Yes, 2=No	1=Yes
S4: Clock Visible	Show Clock: Yes or No; 1=Yes, 2=No	1=Yes
<b>Non- Convection Ovens</b> S5: Oven Temperature Offset Upper Oven S6: Oven Temperature Offset Lower Oven For non- convection doubles, s5 is upper oven temp offset and s6 is lower oven temp offset. (Non- convection ovens do not have a fan at the inside back of the oven cavity)	Sets the oven offset value (affects upper cavity only on double ovens). This value is added to the oven cavity temperature set point (makes oven hotter or cooler if food is consistently either too brown or too light). The allowable range of increment is 0° to 35° F (0 ° to 19 °C), positive or negative. Temperature offset does not affect Self Clean, Broil, Conv. Broil, Warm or Pizza modes.	0



<p><b>Convection Ovens</b></p> <p>S5: Auto Convection Conversion</p> <p>(Convection ovens have a fan at the inside back of the oven cavity)</p>	<p>Toggles automatic convection conversion adjustment of cooking temperatures (available only on convection ovens).</p> <p>Decreases oven temperature by 25° F for Convection Bake and Convection Multi-Rack cooking modes. On, Off.</p> <p>1=On 2=Off</p>	<p>2=Off.</p>
<p><b>Convection Oven</b></p> <p>S6: Oven Temperature Offset</p> <p>Upper Oven for Double Ovens</p> <p>(Convection ovens have a fan at the inside back of the oven cavity)</p>	<p>Sets the oven offset value (affects upper cavity only on double ovens). This value is added to the oven cavity temperature set point (makes oven hotter or cooler if food is consistently either too brown or too light).</p> <p>The allowable range of increment is 0° to 35° F (0 ° to 19 °C), positive or negative.</p> <p>Temperature offset does not affect Self Clean, Broil, Conv. Broil, Warm or Pizza modes.</p>	<p>0</p>
<p><b>Convection Oven</b></p> <p>S7: Oven Temperature Offset</p> <p>Lower Oven for Double Ovens</p> <p>(Convection ovens have a fan at the inside back of the oven cavity)</p>	<p>Sets the oven offset value (affects lower cavity only on double ovens). This value is added to the oven cavity temperature set point (makes oven hotter or cooler if food is consistently either too brown or too light).</p> <p>The allowable range of increment is 0° to 35° F (0 ° to 19 °C), positive or negative.</p> <p>Temperature offset does not affect Self Clean, Broil, Conv. Broil, Warm or Pizza modes.</p>	<p>0</p>

### Oven Temperature Offset

The oven is calibrated to provide accurate results. This feature is useful if you prefer your foods lighter or darker. When an offset temperature is selected, the actual oven temperature is raised or lowered by this value.

The oven must be turned off in order to set an offset value. Refer to “Temperature Offset” in “Settings Menu Options” for setting.



# Getting the Most Out of Your Appliance

## General Tips

### Pan Placement

Baking results are better if pans are placed in the center of the oven. If baking more than one pan on a rack, allow at least 1" to 1 ½" of air space around the pan. When baking four cake layers at the same time, stagger pans on two racks so that one pan is not directly above the other.

### Rack Position

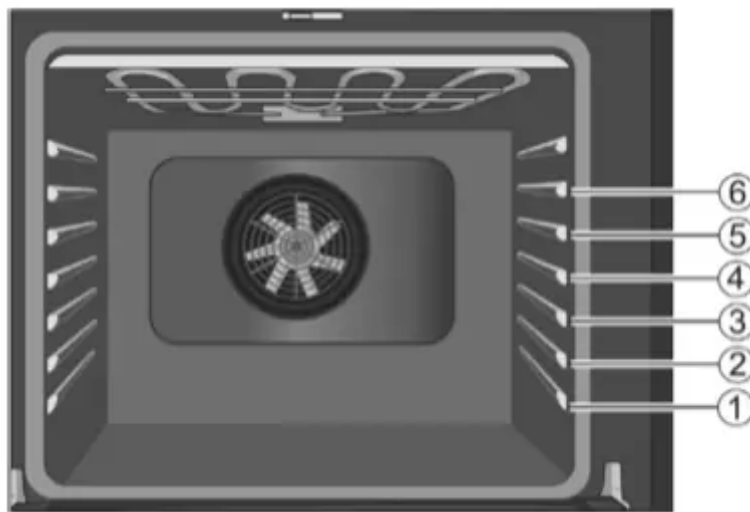

Rack positions are numbered from 1 to 6, from bottom to top. Consult the food cooking charts at the back of this manual for recommended rack positions.

The top rack guide is not used with the cooking racks. Use rack positions 1 through 6 only. The top guide is there only to bracket the rack and prevent it from tipping when inserted in position 6.

Inserting a rack onto the top guide would not be stable, since there is no guide above it to prevent tipping. DO NOT attempt to use the top guide to support a rack.

<b>Rack Position</b>	<b>Best For</b>
6 (highest usable position)	hamburgers, steaks
5	toasting bread, broiling most meats, melting cheese
4	thicker meats
3	broiling poultry, most baked goods on a cookie sheet or baking pan using a single rack, includes frozen convenience foods, cakes, casseroles, frozen pizza
2	small roasts or poultry, bundt cakes, pies, breads
1 (lowest position)	large roasts, turkey, angel food cake

## **Aluminum Foil**

Do not use aluminum foil or protective liners to line any part of the appliance, especially the oven bottom. Installing these liners may result in risk of electric shock or fire.

## **Preheating the Oven**

- Place oven racks in desired position before heating the oven.
- Preheat the oven when using the Bake, Convection Bake, Convection Multi-Rack, Pizza, Broil, and Warm modes.
- Allow oven to preheat while preparing recipe ingredients or food items.
- Setting a higher temperature does not shorten preheat time.
- Once oven is preheated, place food in the oven as quickly as possible to minimize the loss of heat and reduction of oven temperature.

## **Preheat Reminders**

Your oven has one of the fastest preheat times in the market using a concealed bake element. The lower element is hidden under the oven bottom. It is normal that the preheat time is different than your previous oven that had an exposed element on the bottom.

- Cleaning the oven is easier because there is no cleaning around a coil element showing on the bottom of the oven. The hidden lower element is protected from food soils and spills. Wiping up excess spills is easy.

- Preheating is not necessary for meats, poultry, casseroles and frozen foods.
- Preheat time will be longer when the electrical supply to your house is less than 240 volts.
- Increasing the oven temperature will require a longer preheat time. For example, the preheat time for 425° F is longer than the preheat time for 350° F.

When broiling, preheat the oven 3-4 minutes. Do not preheat for more than 5 minutes.

### **For Best Results**

- Use the cooking recommendations as a guide.
- Open the door as briefly as possible to avoid temperature reduction.
- Use the interior oven light to view the food through the oven window rather than opening the door frequently.
- Use the Kitchen Timer to keep track of cooking times.

### **Baking Pans and Dishes**

- Glass baking dishes absorb heat. Reduce oven temperature 25° F when baking using glass dishes.
- Preheat the oven before adding glass baking dishes.
- Use pans that provide the desired browning. For tender, light, golden-brown crusts, use light, anodized, or shiny metal bakeware.
- Dark, rough or dull pans (nonstick or anodized) will absorb heat and result in a browner, crisper crust. Some manufacturers recommend reducing the temperature 25° F when using this type of pan. Follow manufacturers' recommendations.
- Insulated cookie sheets or bakeware will increase the length of cooking time.
- Do not set any heavy object on the open oven door.
- Do not keep empty pans or pizza stones in the oven during cooking as this could change the cooking performance. Store the pans outside the oven.

### **Opening the Oven Door**

- Open and close the appliance door only by holding the door handle. To avoid risk of burns, do not touch any other parts of the door.
- Avoid leaving the door open longer than is necessary and warn others to avoid unintentional contact with the open oven door.

### **High Altitude Baking**

- When cooking at high altitudes, recipes and cooking times will vary.

- For accurate information, write the Extension Service, Colorado State University, Fort Collins, Colorado 80521. There may be a cost for the guides. Specify which high altitude food preparation guide you prefer: general information, cakes, cookies, breads, etc.

## Condensation

- It is normal for a certain amount of moisture to evaporate from the food during any cooking process. The amount depends on the moisture content of the food. The moisture may condense on any surface cooler than the inside of the oven, such as the control panel.

## Temperature Range (°F) by Cooking Mode

Mode	Lowest	Highest
Bake	100	550
Roast	100	550
Broil (Low, High)	450	550
Warm	150	225
Proof (single oven)	100	125
Proof (double oven)	85	125
Convection Bake*	100	550
Convection Multi-Rack*	100	550
Convection Roast*	100	550
Pizza*	100	550
Convection Broil* (Low,High)	450	550

\* Some models only

## Cooking Modes

### Bake



Bake is cooking with dry, heated air. Both the upper and lower elements cycle to maintain the oven temperature.

The Bake mode can be used to prepare a variety of food items, from pastries to casseroles. Refer to recipe or package directions for oven temperature and baking time.

### Tips

- When using the Bake mode, preheat the oven if the recipe recommends it.
- Baking time will vary with the size, shape and finish of the bake ware. Dark metal pans or nonstick coatings will cook faster with darker results. Insulated bakeware will lengthen the cook time for most foods.
- For best results, bake food on a single rack with at least 1 to 1 1/2 "space between pans or dishes and the oven walls.
- Eliminate heat loss from the oven by using the window to periodically check food for doneness instead of opening the door.

### Auto Convection Conversion (some models)

Convection Bake and Convection Multi-Rack modes require a 25° F reduction in temperature. Auto Convection Conversion reduces the temperature you enter automatically. Simply enter the package or recipe temperature when setting the mode. The control calculates the correct temperature and it is shown in the display.

The Auto Convection Conversion feature can be turned on to allow for automatic temperature adjustments. See "Auto Convection Conversion" in the "Settings" section for details.

### Convection Bake (some models)

	Convection Bake is similar to Bake. Heat comes from the upper and lower heating elements. The main difference in convection baking is that the heat is circulated throughout the oven by the convection fan.
---	--

The Convection Bake mode is well suited for cakes, bar cookies and breads to take advantage of the bottom heat, yielding a better crust on baked items.

The benefits of Convection Bake include:

- Slight decrease in cook time.
- Higher volume (yeast items rise higher).

### Tips

- Place food in shallow, uncovered pans such as a cookie sheet without sides.
- If baking more than one pan on a rack, allow at least 1" to 1 1/2" of air space around the pan. Stagger pans so that one is not directly above the other (see graphic below).

- For cakes use rack positions 2 and 5.

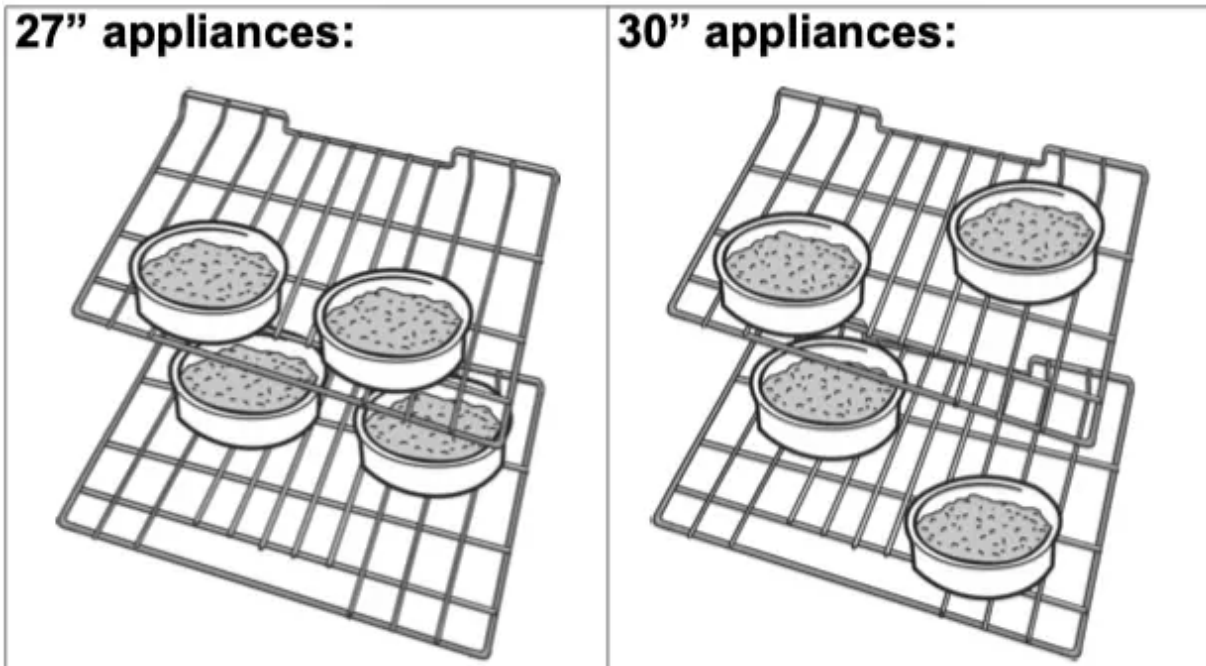

### Convection Multi-Rack (some models)

	<p>Convection Multi-Rack mode cooks with heat from a third element behind the back wall of the oven. The heat is circulated throughout the oven by the convection fan.</p>
---	--

The Convection Multi-rack mode is well suited for cooking individual serving-sized foods such as cookies and biscuits. It is also good for cooking on multiple racks (2 or 3) at the same time. Baking cookies is possible on 6 racks simultaneously. In this case, the baking time increases slightly.

The benefits of Multi-Rack include:

- Even browning.
- Time savings as a result of using multiple racks at one time.

### Tips

- Reduce recipe temperature by 25° F if Auto Convection Conversion is not activated.
- Place food in low-sided, uncovered pans such as cookie sheet without sides.
- If baking more than one pan on a rack, allow at least 1" to 1 1/2" of air space around the pan.

## Pizza (some models)



In the Pizza mode, heat from the upper and lower elements is circulated throughout the oven by the convection fan.

Use the Pizza mode for fresh or frozen pizza.

### Tips

- There might be a slight decrease in baking time. Check before minimum package time.
- When baking a frozen pizza: For a crispy crust, place pizza directly on the rack. For a softer crust, use a pizza pan.
- When proofing pizza dough, coat dough with olive oil and place it in a bowl tightly covered with plastic wrap to prevent crust formation.
- Sprinkle cornmeal on the pizza pan to prevent sticking.
- If using a pizza paddle, sprinkle the paddle liberally with cornmeal for ease in transferring the dough to the pan.
- If par baking handmade pizza dough, prick the dough with a fork before baking.
- If using a pizza pan, choose a dark, perforated pan for a more crisp crust and a non-perforated pan for a softer crust.
- Preheat baking stones following manufacturer's recommendations while the oven is preheating.
- Bake homemade pizza on rack position 2 in the center of the rack.
- Follow manufacturer's directions for frozen pizza.
- The convection fan cycles on and off when using pizza mode.

## Roast



Roast uses both the upper and lower elements to maintain the oven temperature. Roasting uses more intense heat from the upper element than the lower element. This results in more browning of the exterior while the inside remains especially moist.

Roast is best suited for large cuts of meat and poultry.

### Tips:

- Preheating the oven is not necessary.
- Use a high-sided pan, or cover dish with a lid or foil for less tender cuts of meat.
- Use a meat thermometer to determine the internal temperature of the meat.
- If the meat is browned to your liking, but is not yet done, a small strip of foil can be placed over the meat to prevent over-browning.
- Let meat stand covered with foil 10–15 minutes after removing it from the oven.
- Roasting bags and using a lid are suitable for use in this mode.
- When roasting whole chicken or turkey, tuck wings behind back and loosely tie legs with kitchen string.
- Add liquids, such as water, juice, wine, bouillon or stock for flavor and moisture.

### Convection Roast (some models)



Convection Roast uses heat from the top and bottom elements as well as heat circulated by the convection fan.

The Convection Roast mode is well suited for preparing tender cuts of meat and poultry. It is also suitable for roasting vegetables.

The benefits of Convection Roast include:

- As much as 25% faster cooking than non-convection modes.
- Rich, golden browning.

#### Tips:

- Preheating the oven is not necessary.
- Use the same temperature as indicated in the recipe.
- Check doneness early, since roasting time may decrease. Refer to the Meat/Poultry cooking chart for examples.
- Do not cover meat or use cooking bags.
- Use a broil pan with a rack and grid or a shallow, uncovered pan for roasting.
- Use a meat thermometer to determine the internal temperature of the meat.
- If the meat is browned to your liking, but is not yet done, a small strip of foil can be placed over the meat to prevent over-browning.
- Let meat stand covered with foil for 10 to 15 minutes after removing it from the oven.

- Refer to the Meat/Poultry Cooking Chart for recommended rack positions.

## Broil

	<p>Broil uses intense heat radiated from the upper element.</p>
---	---

The Broil mode is best suited for cooking thin, tender cuts of meat (1" or less), poultry and fish. It can also be used to brown breads and casseroles. Always broil with the door closed. The benefits of broiling include:

- Fast and efficient cooking.
- Cooking without the addition of fats or liquids.

### Tips:

- Preheat oven 3–4 minutes. Do not preheat for more than 5 minutes.
- Steaks and chops should be at least ¾" thick.
- Brush fish and poultry with butter or oil to prevent sticking.
- Use a broil pan and grid (or a deep pan with a metal rack) designed to drain fats and oils away from the cooking surface to prevent smoking and spattering.
- Turn meats once during the recommended cook time (for Broil times, refer to the Meat/Poultry Cooking Chart). Fish does not need to be turned.
- When top browning casseroles, use only metal or glass ceramic dishes such as CorningWare®.
- Never use heat-proof glass (Pyrex®); it cannot tolerate the high temperature.
- Broiling times are approximate and may vary slightly. Times are based on cooking with a preheated broil element.

## Convection Broil (some models)

	<p>Convection Broil is similar to Broil. It combines intense heat from the upper element with heat circulated by a convection fan.</p>
---	--

The Convection Broil mode is well suited for cooking thick, tender cuts of meat, poultry and fish. Convection Broil is not recommended for browning breads, casseroles and other foods. Always use convection broil with the door closed.

In addition to the benefits of standard broiling, convection broiling is faster.

## Tips:

- Preheat oven 3–4 minutes. Do not preheat for more than 5 minutes.
- Steaks and chops should be at least 1 1/2" thick.
- Use a broil pan and grid (or a deep pan with a metal rack) for broiling.
- Do not cover the broil grid with foil. It is designed to drain fats and oils away from the cooking surface to prevent smoking and spattering.
- Turn meats once during the recommended cook time.
- Never use heat-proof glass (Pyrex ®); it cannot tolerate the high temperature used for broiling. For Convection Broil times, refer to the Meat/ Poultry Cooking Chart.

## Warm



In Warm, the upper and lower elements maintain a low temperature in the oven cavity in order to keep food at serving temperature.

- Use the Warm mode to keep cooked foods hot until ready to serve.
- Warm mode temperatures are 150° F – 225° F.
- The default temperature in the Warm mode is 170° F.
- Foods that must be kept moist should be covered with a lid or aluminum foil.

## CAUTION

When using Warm mode, follow these guidelines:

- Do not use the Warm mode to heat cold food.
- Be sure to maintain proper food temperature. The USDA recommends holding hot food at 140° F or warmer.
- DO NOT warm food longer than one hour.

## Proof



In Proof, the oven uses the lower element to maintain a low temperature to proof bread or other yeast doughs.

- No preheat is necessary.
- Proofing is the rising of yeast dough.

- The Proof mode temperature range for single ovens is 100° F to 125° F and for double ovens is 85° F to 125° F.
- The default temperature in the Proof mode is 100° F.
- Loosely cover the bowl or pan and use any rack that accommodates the size of the container.
- Keep the oven door closed and use the oven light to check the rising of the dough.

## Cleaning and Maintenance

### Cleaning

#### Self Clean

#### WARNING

Children should not be left alone or unattended in an area where appliances are in use. During the Self Clean cycle, parts of the appliance may become potentially harmful to persons who lack adult knowledge of appliances and adult reactions to potentially harmful conditions.

During the elimination of soil during self-cleaning, small amounts of carbon monoxide can be created. Fiberglass insulation could give off very small amounts of formaldehyde during the first several cleansing cycles. To minimize exposure to these substances, provide good ventilation with an open window, or use a ventilation fan or hood.

#### Self Clean

During Self Clean, the oven is heated to a very high temperature. Soil is burned off at this temperature.

#### NOTICE:

- Wipe out excessive spillage before self-cleaning the oven.
- Do not clean parts or accessories in the Self Clean oven. Remove all baking dishes and oven racks from the oven prior to running Self Clean.

#### Single Ovens

To set the Self Clean mode:

1. Remove all accessories and racks from the oven.
2. Self Clean will not run if a timer is active. Clear all running timers before attempting to start Self Clean.
3. Turn the Cooking Mode Dial to Self Clean.
4. Turn the Temperature Settings Dial to Self Clean.
5. After 3 seconds, the display blinks "--:--".

6. Press the + or - key to set the Self Clean time. The maximum is 4 hours and the minimum is 2 hours.

7. When the time in the display is unchanged for 3 seconds, Self Clean begins. The Self Clean LED is illuminated.

The oven door is automatically locked during Self Clean.



8. When the Self Clean display shows "0:00", Self Clean ends.

9. Wipe remaining ash from the oven using a moist cloth.

10. To cancel Self Clean, turn the Cooking Mode Dial to "Off".

**Note:**

- The oven light cannot be turned on during self-cleaning.
- The special heat-resistant enamel and the polished components in the oven can become discolored over time. This is normal and does not affect operation. Do not use scouring pads or abrasive cleaners to treat discolorations.

**Double Ovens**

Only one oven cavity can run the Self Clean mode at a given time.

To set the Self Clean mode:

1. Remove all accessories and racks from the oven.
2. Self Clean will not run if a timer is active. Clear all running timers before attempting to start Self Clean.
3. Turn the Cooking Mode Dial for the selected oven cavity (upper or lower) to Self Clean.
4. After 3 seconds, the display blinks "--:--".



5. Press the + or - key to set the Self Clean time. The maximum is 4 hours and the minimum is 2 hours.

6. When the time in the display is unchanged for 3 seconds, Self Clean begins. The Self Clean LED for the cavity is illuminated.



7. When the Self Clean display shows "0:00", Self Clean ends.

8. Wipe remaining ash from the oven using a moist cloth.

9. To cancel Self Clean, turn the Cooking Mode Dial to "Off".

**Note:**

- The oven light cannot be turned on during self-cleaning.
- The special heat-resistant enamel and the polished components in the oven can become discolored over time. This is normal and does not affect operation. Do not use scouring pads or abrasive cleaners to treat discolorations.

**Avoid These Cleaners**

Do not use commercial oven cleaners such as Easy Off®. They may damage the oven finish or parts.

Never use scouring pads or abrasive cleaners. Never use cleansers containing Clorox®.

Do not use flammable cleaners such as lighter fluid or WD-40.

Chlorine or chlorine compounds in some cleaners are corrosive to stainless steel. Check ingredients on label before using.



## Cleaning Guide



<b>Part</b>	<b>Recommendations</b>
<b>Flat Rack</b>	<p>Wash with hot soapy water. Rinse thoroughly and dry, or gently rub with cleansing powder or soap-filled pads as directed. DO NOT clean the rack in the Self Clean oven.</p> <p>If flat racks are cleaned in the oven during the Self Clean mode, they will lose their shiny finish and may not glide smoothly. If this happens wipe the rack edges with a small amount of vegetable oil. Then wipe off excess.</p>
<b>Fiberglass Gasket</b>	DO NOT CLEAN GASKET.
<b>Glass</b>	Wash with soap and water or glass cleaner. Use Fantastik® or Formula 409® to remove grease splatters and stubborn stains.
<b>Painted Surfaces</b>	Clean with hot soapy water or apply Fantastik® or Formula 409® to a clean sponge or paper towel and wipe clean. Avoid using powder cleaning agents, steel wool pads and oven cleaners.
<b>Porcelain Surfaces</b>	Immediately wipe up acid spills like fruit juice, milk and tomatoes with a dry cloth. Do not use a moistened sponge/cloth on hot porcelain. When cool, clean with hot soapy water or apply Bon-Ami® or Soft Scrub® to a damp sponge. Rinse and dry. For stubborn stains, use soap-filled pads. It is normal for porcelain to show fine lines with age due to exposure to heat and food soil.
<b>Stainless Steel Surfaces</b>	<p>Always wipe or rub in the direction of the grain. Clean with a soapy sponge, then rinse and dry, or wipe with Fantastik® or Formula 409® sprayed on a paper towel. Protect and polish with Stainless Steel Magic® and a soft cloth. Remove water spots with a cloth dampened with white vinegar. Do not use any abrasives such as steel wool pads, SoftScrub®, BonAmi® or Clorox® cleansers.</p> <p>Chlorine or chlorine compounds in some cleaners are corrosive to stainless steel. Check ingredients on label before using.</p>
<b>Plastic &amp; Controls</b>	When cool, clean with soapy water, rinse and dry.
	Do not use abrasive cleansers. When cool, clean with soapy water, rinse, dry.

## Maintenance

### Replacing an Oven Light

#### WARNING

- Make sure the appliance and lights are cool and power to the appliance has been turned off before replacing the light bulb(s). Failure to do so could result in electrical shock or burns.
- The lenses must be in place when using the appliance.
- The lenses serve to protect the light bulb from breaking.
- The lenses are made of glass. Handle carefully to avoid breaking. Broken glass could cause an injury.
- Light socket is live when door is open.

#### To change the bulb:

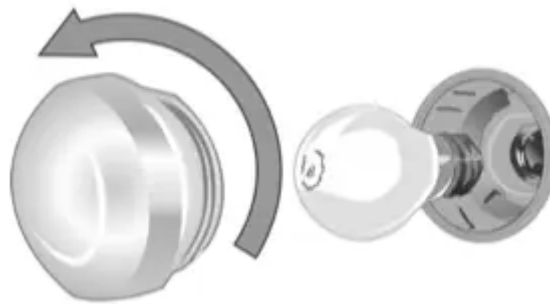

1. Turn off power to the oven at the main power supply (fuse or breaker box).
2. Remove the glass cover by unscrewing it. Turn the glass counterclockwise to remove it.
3. Remove the bulb. The bulb unscrews counterclockwise.
4. Grasp the new bulb with a clean, dry cloth to prevent depositing skin oils on the glass which could lead to premature bulb failure. Replace the bulb by screwing it in turning the bulb clockwise.
5. Screw the glass cover back on.
6. Turn power back on at the main power supply (fuse or breaker box).

### Removing the Oven Door

#### WARNING

When removing the door:

- Make sure oven is cool and power to the oven has been turned off before removing the door. Failure to do so could result in electrical shock or burns.
- The oven door is heavy and parts of it are fragile. Use both hands to remove the oven door. The door front is glass. Handle carefully to avoid breakage.
- Grasp only the sides of the oven door. Do not grasp the handle as it may swing in your hand and cause damage or injury.
- Failure to grasp the oven door firmly and properly could result in personal injury or product damage.
- To avoid injury from hinge bracket snapping closed, be sure that both levers are securely in place before removing the door. Also, do not force door open or closed—the hinge could be damaged and injury could result.
- Do not lay removed door on sharp or pointed objects as this could break the glass. Lay on a flat, smooth surface, positioned so that the door cannot fall over.

**To remove the oven door:**

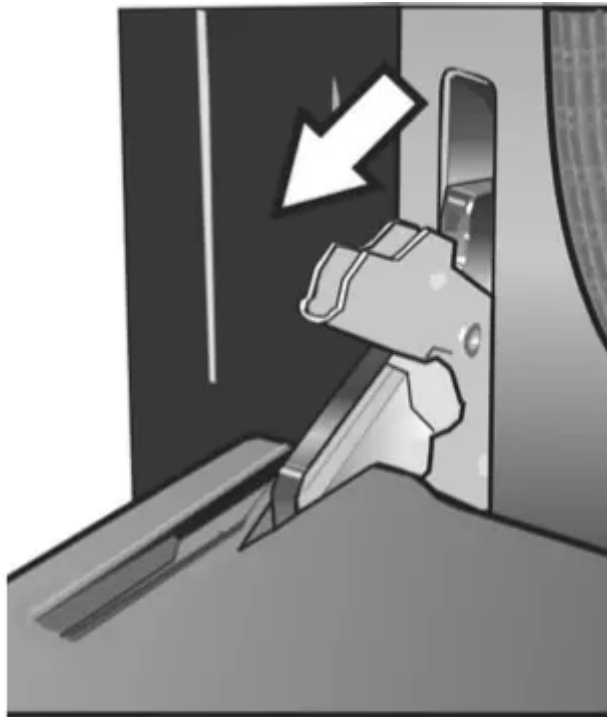

To help avoid injury or damage be sure to read the above WARNING before attempting to remove the oven door.

1. Open the oven door to its fully open, horizontal position.
2. Flip levers on hinges toward you.

**Note:** It may be necessary to use a tool, such as a screwdriver, to gently pry the upper part of the lever away from the housing. Take care to avoid scratching the housing.

3. Bring both door hinge levers to their fullest down position as shown in the illustration. The left and right door hinges differ slightly but operate in the same manner.



4. Close the oven door until it catches on the hinge stop levers, locking the hinges at the proper angle for door removal. The door will be open about 7 inches at the top. This takes the spring tension off the hinges so the door can be easily lifted out.

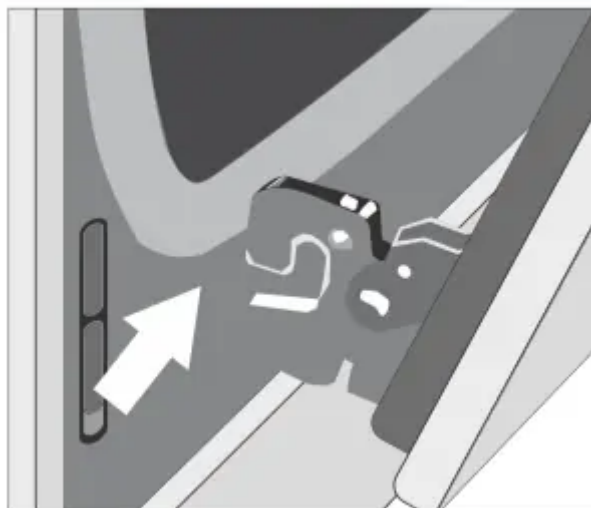

5. The door is heavy. Use both hands to firmly grip it by the sides. Do not grip the door by the handle. Maintaining the door angle, lift the door straight up approximately 3/4" to unhook the hinges from the slots and then pull it out towards you until the hinges are clear of the oven housing.

6. Place the door in a convenient and stable location for cleaning.

**To replace the oven door:**



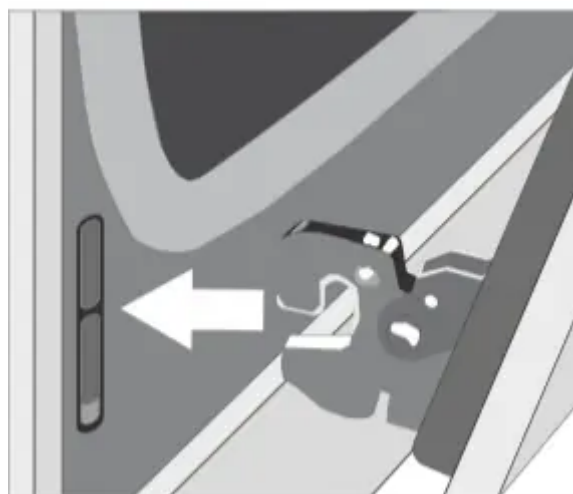

1. Holding the door firmly in both hands, grip it on either side, not by the handle.
2. Tilt the door back slightly towards you until it opens about 7" at the top.
3. Slide the hinges into the slots as far as they will go and then lower the door straight down. The angle of the door may need to be adjusted slightly to allow the hinges to engage properly and the door to lower into place. The door should lower about 3/4" and stop. If not, the hinges have not engaged properly and the door could fall if it is released.
4. Once both hinges are fully engaged as described in Step 3, gently open the door until it is fully open.

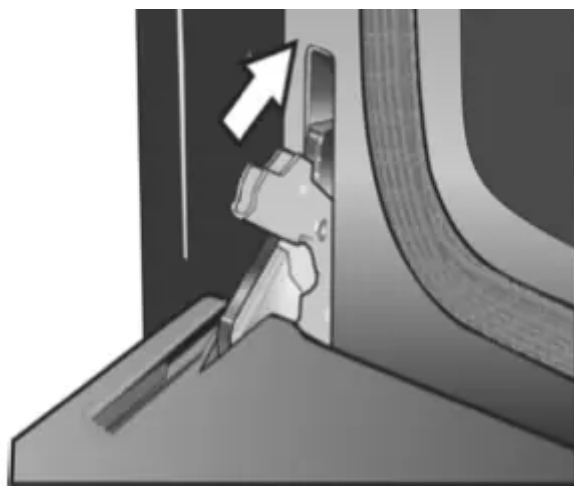

5. Push the levers on both the hinges up and forward until they are locked into the slot, flush with the front of the oven body.
6. Close and open door slowly to be sure it is correctly and securely in place.

## Service

### How to Obtain Service or Parts

To reach a service representative, see the contact information at the front of the manual. Please be prepared with the information printed on your product data plate when calling.

### Data Plate

The data plate shows the model and serial number. Refer to the data plate on the appliance when requesting service. The data plate location varies based on the oven model and door hinge type:

- Single oven with bottom hinge: left hand side of door trim.
- Single oven with side hinge: side opposite the door hinge.
- Double oven with bottom hinge: left hand side of door trim of the lower oven cavity.

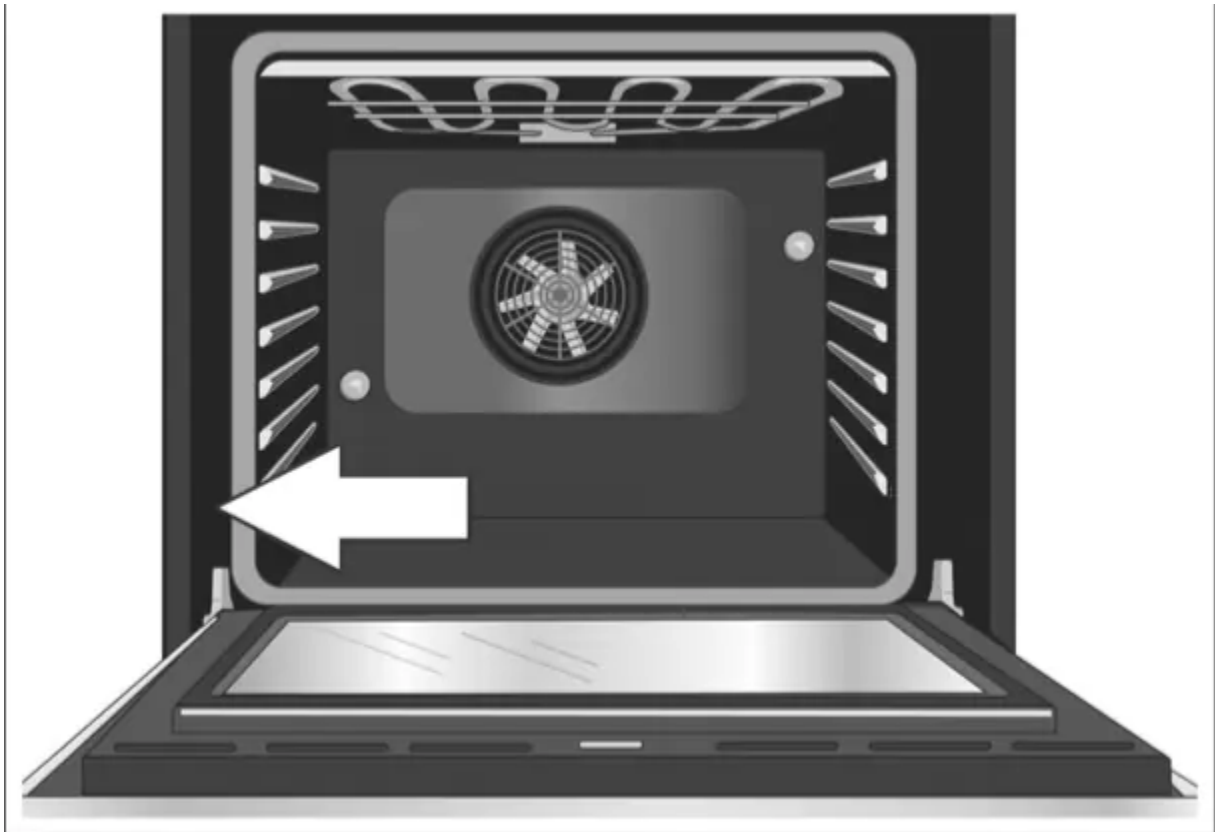

# Troubleshooting Chart



<b>Oven Problem</b>	<b>Possible Causes and Suggested Solutions</b>
<b>Oven door is locked and will not open, even after cooling.</b>	Turn the oven off at the circuit breaker and wait five minutes. Turn breaker back on. The oven should reset itself and will be operable.
<b>Oven is not heating.</b>	Check circuit breaker or fuse box to your house. Make sure there is proper electrical power to the oven. Be sure oven temperature has been selected.
<b>Oven is not cooking evenly.</b>	Refer to cooking charts for recommended rack position. Check "Getting the Most Out of Your Appliance" for tips and suggestions.
<b>Baking results are not as expected.</b>	Refer to cooking charts for recommended rack position. Check "Getting the Most Out of Your Appliance" for tips and suggestions. Adjust oven calibration if necessary. See "Oven Temperature Offset" under "Setting Menu Options".
<b>Food takes longer to cook than expected.</b>	The oven is carefully calibrated to provide accurate results. However, the temperature can be offset if food is consistently too brown or too light. See "Oven Temperature Offset" under "Setting Menu Options".
<b>Food is overcooked.</b>	The oven is carefully calibrated to provide accurate results. However, the temperature can be offset if food is consistently too brown or too light. See "Oven Temperature Offset" under "Setting Menu Options".
<b>Oven light is not working properly.</b>	Replace or reinsert the light bulb if loose or defective. Touching the bulb with fingers may cause the bulb to burn out.
<b>Oven light does not turn off.</b>	Check for obstruction in oven door. Check to see if hinge is bent. Oven light has been turned on: press the oven light button to turn off.
<b>Cannot remove lens cover on light.</b>	There may be soil build-up around the lens cover. Wipe lens cover area with a clean, dry towel prior to attempting to remove the lens cover.



<b>Oven is not self-cleaning properly.</b>	Allow the oven to cool before running Self Clean. Always wipe out loose soils or heavy spillovers before running Self Clean. If oven is badly soiled, set oven for the maximum Self Clean time.
<b>Clock and timer are not working properly.</b>	Make sure there is electrical power to oven.
<b>"E" and a number appears in display and control beeps.</b>	This is a fault code. Press any key or turn knob to stop beeping. Reset oven if necessary. If fault code remains, record fault code, cancel oven, and call authorized service technician.
<b>With a new oven there is a strong odor when oven is turned on.</b>	This is normal with a new oven and will disappear after a few uses. Operating the Self Clean cycle also "burns-off" the smell more quickly.
<b>Control does not react when a key is touched.</b>	Be sure that surface is clean and dry. Touch the center of the button. Use the flat part of your finger.
<b>Warm air or steam escapes from oven vent.</b>	It is normal to see or feel steam or warm air escaping from the oven vent. Do not block the vent.
<b>Cooling fan runs even when the oven is turned off.</b>	This is normal. The cooling fan will continue to run, even after the oven has been turned off, until the oven has cooled sufficiently.

### **Warning**

This content is compiled from multiple sources and is provided for reference purposes only. It may not be complete or fully applicable to all situations. If you are unable to resolve your issue, please contact the product manufacturer or an authorized service provider for official support.

