

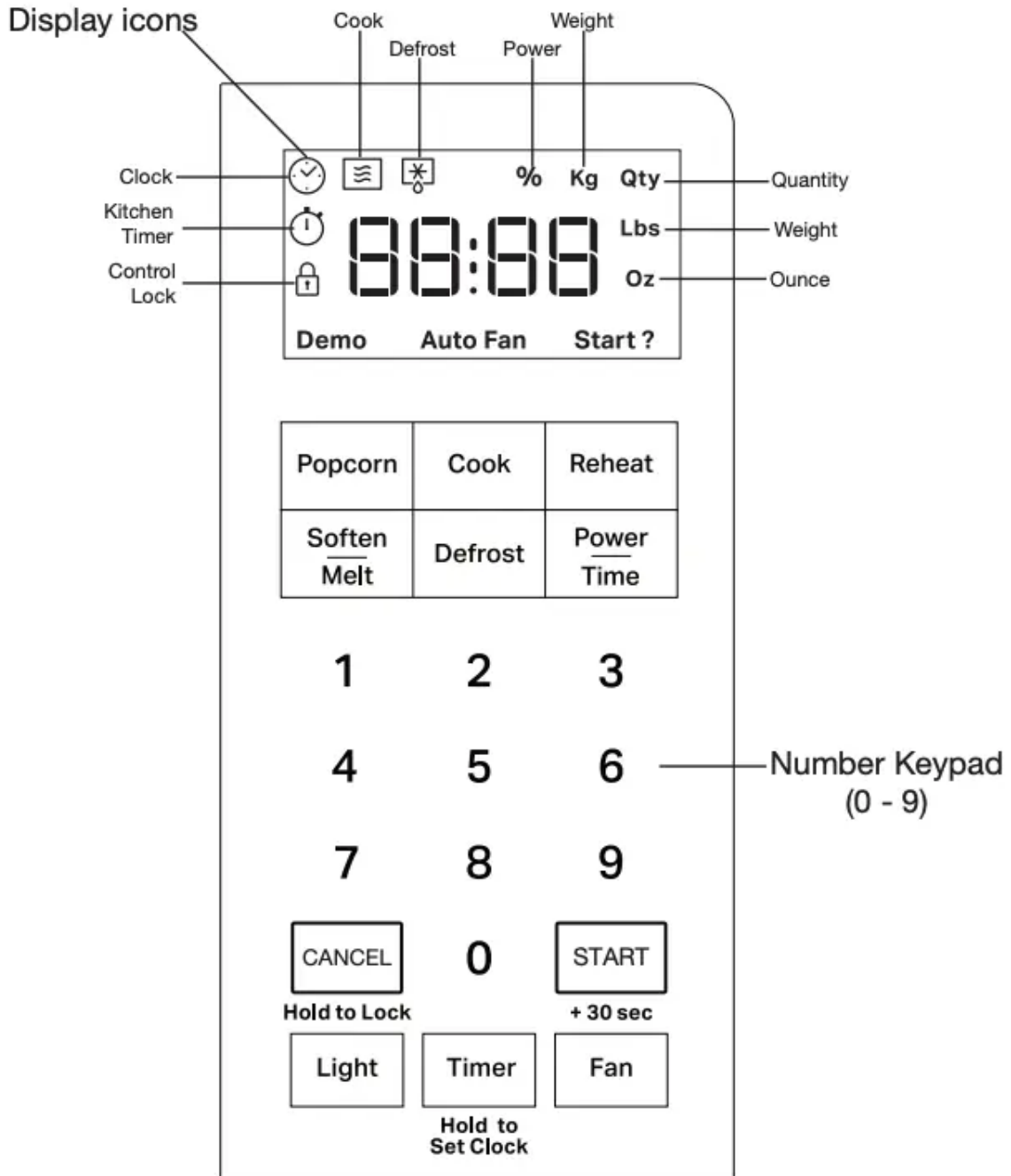











FEATURES

Feature Guide



This manual covers several models. Your model may have some or all of the items listed. Refer to this manual or the Product Help section of our website at [whirlpool](http://whirlpool.com) for more detailed instructions.

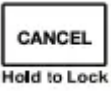
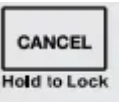

Keypad	Feature	Instructions
	Hold to Set the Clock	<p>This microwave uses a 12 hour (1:00 - 12:59). To set the clock, following the instructions below:</p> <ol style="list-style-type: none"> 1. Hold the TIMER button for about 3 seconds. 2. A tone will sound and the  icon will appear on the display. 3. Use the number keypads to set the clock. 4. Press the START or the TIMER button to save the time. <p>NOTE: After power loss, it may be necessary to reset the clock.</p>
	Set Kitchen Timer	<p>The kitchen timer functions independently of the microwave cooking functions, similar to a stop watch. To set the kitchen timer, following the instructions below:</p> <ol style="list-style-type: none"> 1. Press TIMER button, the  icon will appear on the display. 2. Press the number button to enter time up to 99 minutes and 59 seconds. The “Start?” icon will flash on the display. 3. Press START button. <p>NOTE: When Kitchen Timer is running: The Add 30 Sec will not work.</p> <p>To reset the timer, press the number button, e.g. press the number button 1000, and the kitchen timer will reset to “10:00”. Press START button to start.</p> <p>To run manual cooking mode, press POWER/TIME button.</p> <p>To run an auto cooking mode, press POPCORN / COOK / REHEAT /DEFROST / SOFTEN or MELT button.</p>
	Add 30 Seconds	<p>The button  can be used in two ways:</p> <ol style="list-style-type: none"> 1. To start the microwave by cooking for 30 seconds using the most recent power setting. 2. To increase a cooking time using increments of 30 seconds. <p>Each press adds 30 seconds or pressing and holding the  button will add more time automatically.</p> <p>For example: To add 30 seconds of cook time, press the button once. To add 1 minute of cooking time, press the button twice. To</p>

		<p>add more time, press and hold  button until your preferred cook time is reached.</p> <p>NOTE: Holding the  button will add up to 10 minutes to the current time countdown. When 10 minutes has been added or the max time has been reached, invalid/retry tones will sound and the display will show the final time setting. If you want more time, you can release the keypad, then press and hold the  button again to add up to another 10 minutes.</p>
	Start Function	Press the START button to start any cooking function. If cooking is interrupted by opening the door, touch the START button after the door is closed again to resume the cycle.
	Microwave Oven Cancel	<p>The CANCEL button stops any microwave oven function except for the clock and control lock.</p> <p>The microwave oven will also turn off when the door is opened. When the door is opened, the element(s) will turn off, but the microwave oven light will remain on. Close the door and touch the Start button to resume the preset cycle.</p>
	Activate Control Lock	<p>Activate Control Lock to avoid an unintended start.</p> <p>To activate, press and hold the CANCEL button for 3 seconds until tone sounds and the CONTROL LOCKED icon appears on the display.</p> <p>Repeat to unlock control.</p>
LIGHT	Turn on Hood Light	<p>Press the LIGHT button to turn on the cooktop light. Press LIGHT repeatedly to adjust the light setting among HIGH-> LOW->OFF. The display will show “Hi”, “Lo” and “Off”.</p> <p>NOTE: The cooktop light can be operated independently from any cooking functions or the control lock status.</p>
FAN	Turn on the Fan	<p>Press the FAN button to turn the fan on or off. Press FAN repeatedly to change the fan setting among HIGH-> LOW->OFF. The display will show “Hi”, “Lo” and “Off”. NOTE: The hood fan can be operated independently from any cooking functions or the control lock status.</p>

<p>Number Key “4”</p>	<p>Set the Key Sound (Tones) On/Off</p>	<p>To enable or disable. press and hold number key “4” for about 5 seconds to disable key tones. Repeat to turn key tones back on.</p> <p>NOTE:</p> <ul style="list-style-type: none"> ■ Only key entry tones are turned off. Other tones such as end of cycle tones are not affected. ■ Tones can only activated or deactivated when the microwave is idle.
<p>Number Key “3”</p>	<p>Activate Demo Mode</p>	<p>Demo mode shows the display and controls, including lights and fans, without using the magnetron, thus preventing microwave functions. To activate or deactivate Demo Mode in idle state.</p> <p>To Activate/Deactivate: Press and hold number key “3” for about 5 seconds.</p>
<p>Number Key “9”</p>	<p>Factory Reset</p>	<p>The microwave can be reset back to default state. To Activate factory reset mode, press and hold number key “9” for about 10 seconds.</p> <p>NOTE: The microwave must be idle for factory reset.</p>
<p>Power/ Time</p>	<p>Set Manual Cooking Power and Time</p>	<p>Press POWER/TIME to set manual power and cooking time. The default power level is 100%. Press any number keypad to change the power level. For example, to set the time to 2:30 in 90% power level.</p> <ol style="list-style-type: none"> 1. Press POWER/TIME. The icon will show on the display. 2. Press keypad 9 to set the power level at 90%. 3. Press POWER/TIME again. The  icon will show on the display. 4. Use the number keypads to enter the cooking time length 2:30. The “Start?” icon will flash on the display. 5. Press Start button. When the stop time is reached, the microwave oven will shut off automatically, and the end tone will sound.
<p>DEFROST</p>	<p>Automatic Defrost</p>	<p>The defrost function helps thaw frozen food. To defrost, follow the instructions below:</p>

		<ol style="list-style-type: none"> 1. Press DEFROST. The  icon will show on the display. 2. Use the number keypads to select a food category. See the DEFROST section in this guide for the food category or reference the sticker on the door of the microwave. 3. Use the number keypads to enter the weight. 4. Press Start button. The display will count down the defrost time. For better results, a preset standing time is included in the defrosting time. This may make the defrosting time seem longer than expected. When the stop time is reached, the microwave oven will shut off automatically, and the end tone will sound.
REHEAT	Automatic Reheat	<p>To reheat using preset functions, follow the instructions below:</p> <ol style="list-style-type: none"> 1. Press REHEAT. The  icon will show on the display. 2. Use the number keypads to select a food category. See the REHEAT section in this guide for the food category or reference the sticker on the door of the microwave. 3. Use the number keypads to enter the quantity. 4. Press START button. When the stop time is reached, the microwave oven will shut off automatically, and the end tone will sound.
POPCORN	Popcorn	<p>To use the popcorn preset, follow the instructions below:</p> <ol style="list-style-type: none"> 1. Press POPCORN repeatedly to select the bag size. 3.0 oz is the default bag size. "Start?" will flash on the display. 2. Press the START button. When the stop time is reached, the microwave oven will shut off automatically, and the end tone will sound.
SOFTEN/ MELT	Soften/Melt	<p>The SOFTEN/MELT function is used to soften or melt food. To use:</p> <ol style="list-style-type: none"> 1. Press SOFTEN/MELT. The  icon will show on the display. 2. Use the number keypads to select a food category, see the SOFTEN/MELT section in this guide for the food category or reference the sticker on the door of the microwave.

		<p>3. Use the number keypads to enter the quantity. “Start?” will flash on the display.</p> <p>4. Press START button. When the stop time is reached, the microwave oven will shut off automatically, and the end tone will sound.</p>
COOK	Auto Cook	<p>To use the auto cook presets, follow the instructions below:</p> <ol style="list-style-type: none"> 1. Press COOK. The  icon will show on the display. 2. Use the number keypads to select a food category. See the COOK section in this guide for the food category or reference the sticker on the door of the microwave. 3. Use the number keypads to enter the quantity. “Start?” will flash on the display 4. Press Start button. When the stop time is reached, the microwave oven will shut off automatically, and the end tone will sound.

Standby Mode

When no functions are being used, the microwave oven will switch to Standby Power mode and slightly dim the display brightness after about 2 minutes. Touch any key or open/close the door, and the display will return to the normal brightness.

Auto Vent Fan

To keep the microwave oven from overheating, the auto vent fan will automatically turn on if the temperature from the range or cooktop below exceeds a certain temperature. When this occurs, the vent fan cannot be turned off and the fan speed cannot be changed. “AUTO FAN” will stay lit until the microwave oven cools.

Control Lock

The Control Lock shuts down the control panel keypad to avoid unintended use of the microwave oven. When the control is locked, only the fan and light will function.

To Lock Control: Touch CANCEL for approximately 3 seconds, until a tone sounds and a  icon appears on the display.

To Unlock Control: Repeat to unlock. A tone will sound and the  icon will be removed

MICROWAVE OVEN USE

A magnetron in the microwave oven produces microwaves which reflect off the metal floor, walls, and ceiling and pass through the turntable and appropriate cookware to the food. Microwaves are attracted to and absorbed by fat, sugar, and water molecules in the food, causing them to move, producing friction and heat which cooks the food.

- To avoid damage to the microwave oven, do not lean on or allow children to swing on the microwave oven door.
- To avoid damage to the microwave oven, do not operate microwave oven when it is empty, even with an empty container.
- The turntable must be in place and correct side up when the microwave oven is in use. Do not use if the turntable is chipped or broken.
- Baby bottles and baby food jars should not be heated in the microwave oven.
- Clothes, flowers, fruit, herbs, wood, gourds, and paper, including brown paper bags and newspaper, should not be dried in the microwave oven.
- Paraffin wax will not melt in the microwave oven because it does not absorb microwaves.
- Use oven mitts or pot holders when removing containers from the microwave oven.
- Do not overcook potatoes. At the end of the recommended cook time, potatoes should be slightly firm. Let potatoes stand for 5 minutes. They will finish cooking while standing.
- Do not cook or reheat whole eggs inside the shell. Steam buildup in whole eggs may cause them to burst. Cover poached eggs and allow a standing time.

Food Characteristics

When the microwave oven is cooking, the amount, size and shape, starting temperature, composition and density of the food will affect the cooking results.

Amount of Food

The more food that is heated at once, the longer the cook time that is needed. Check for doneness and add small increments of time, if necessary.

Size and Shape

Smaller pieces of food will cook more quickly than larger pieces, and uniformly shaped food cooks more evenly than irregularly shaped food.

Starting Temperature

Room temperature foods will heat faster than refrigerated foods, and refrigerated foods will heat faster than frozen foods.

Composition and Density

Foods high in fat and sugar will reach a higher temperature and will heat faster than other foods. Heavy, dense foods, such as meat and potatoes, require a longer cook time than the same size of a light, porous food, such as cake.

Cooking Guidelines

Covering

Covering food helps retain moisture, shorten cook time, and reduce spattering. Use the lid supplied with cookware. If a lid is not available, wax paper, paper towels, or plastic wrap approved for microwave ovens may be used. Plastic wrap should be turned back at one corner to provide an opening to vent steam.

Condensation on the door and cavity surfaces is normal during heavy cooking.

Stirring and Turning

Stirring and turning redistributes heat evenly to avoid overcooking the outer edges of food. Stir from outside to center. If possible, turn food over from bottom to top.

Arranging

If heating irregularly shaped or different-sized foods, arrange the thinner parts and smaller-sized items toward the center. If cooking several items of the same size and shape, place them in a ring pattern, leaving the center of the ring empty.

Piercing

Before heating, use a fork or small knife to pierce or prick foods that have a skin or membrane, such as potatoes, egg yolks, chicken livers, hot dogs, and sausage. Prick in several places to allow steam to vent.

Shielding

Use small, flat pieces of aluminum foil to shield the thin pieces of irregularly shaped foods, bones, and foods such as chicken wings, leg tips, and fish tails. See the "Aluminum Foil and Metal" section first.

Standing Time

Food will continue to cook by the natural conduction of heat, even after the microwave cooking cycle ends. The length of standing time depends on the volume and density of the food.

Cookware and Dinnerware

Cookware and dinnerware must fit on the turntable. Always use oven mitts or pot holders when handling because any dish may become hot from heat transferred from the food. Do not use cookware and dinnerware with gold or silver trim. Use the following chart as a guide, then test before using.

Material	Recommendations
Aluminum Foil, Metal	See the “Aluminum Foil and Metal” section.
Browning Dish	Bottom must be at least 3/16" (5 mm) above the turntable. Follow manufacturer’s recommendations.
Ceramic Glass, Glass	Acceptable for use.
China, Earthenware	Follow manufacturer’s recommendations.
Melamine	Follow manufacturer’s recommendations.
Paper: Towels, Dinnerware, Napkins	Use non-recycled and those approved by the manufacturer for microwave oven use.
Plastic: Wraps, Bags, Covers, Dinnerware, Containers	Use those approved by the manufacturer for microwave oven use.
Pottery and Clay	Follow manufacturer’s recommendations.
Silicone Bakeware	Follow manufacturer’s recommendations.
Straw, Wicker, Wooden Containers	Do not use in microwave oven.
Styrofoam®†	Do not use in microwave oven
Wax Paper	Acceptable for use.

To Test Cookware or Dinnerware for Microwave Use:

- 1. Place cookware or dinnerware in microwave oven with 1 cup (250 mL) of water beside it.
- 2. Cook at 100% cooking power for 1 minute.

Do not use cookware or dinnerware if it becomes hot and the water stays cool.

Aluminum Foil and Metal

Always use oven mitts or pot holders when removing dishes from the microwave oven.

Aluminum foil and some metal can be used in the microwave oven. If not used properly, arcing (a blue flash of light) can occur and cause damage to the microwave oven.

OK for Use



Racks and bakeware supplied with the microwave oven (on some models), aluminum foil for shielding, and approved meat thermometers may be used with the following guidelines:

- To avoid damage to the microwave oven, do not allow aluminum foil or metal to touch the inside cavity walls, ceiling, or floor.
- Always use the turntable.
- To avoid damage to the microwave oven, do not allow contact with another metal object during microwave cooking.

Do Not Use

Metal cookware and bakeware, gold, silver, pewter, non-approved meat thermometers, skewers, twist ties, foil liners, such as sandwich wrappers, staples, and objects with gold or silver trim or a metallic glaze, should not be used in the microwave oven.

Metal bakeware may be used only during convection (bake) cycles. Use ovenproof, microwave-safe cookware for all other convection and combination cooking.

Microwave Cooking Power

Many recipes for microwave cooking specify which cooking power to use by percent, name, or number. For example, 70%=MediumHigh=7.

Use the following chart as a general guide for the suggested cooking power of specific foods.

MICROWAVE COOKING POWER CHART

Percent/ Name	Number	Use
100%, High (default setting)	10	Quick-heating convenience foods and foods with high water content, such as soups, beverages, and most vegetables.
90%	9	Cooking small, tender pieces of meat, ground meat, poultry pieces, and fish fillets. Heating cream soups.
80%	8	Heating rice, pasta, or casseroles. Cooking and heating foods that need a cook power lower than high, for example, whole fish and meat loaf.
70%, MediumHigh	7	Reheating a single serving of food.
60%	6	Cooking sensitive foods such as cheese and egg dishes, pudding, and custards. Cooking non-stirtable casseroles, such as lasagna.
50%, Medium	5	Cooking ham, whole poultry, and pot roasts. Simmering stews.
40%	4	Melting chocolate. Heating bread, rolls, and pastries.
30%, Medium-Low, Defrost	3	Defrosting bread, fish, meats, poultry, and precooked foods.
20%	2	Softening butter, cheese, and ice cream.
10%, Low	1	Taking chill out of fruit.

Defrost

- For optimal results, food should be 0°F (-18°C) or colder when defrosting.
- Unwrap foods and remove lids (from fruit juice) before defrosting.
- Shallow packages will defrost more quickly than deep blocks.
- Separate food pieces as soon as possible during or at the end of the cycle for more even defrosting.
- Foods left outside the freezer for more than 20 minutes or frozen ready-made food should not be defrosted using the Defrost feature but should be defrosted manually.

- Use small pieces of aluminum foil to shield parts of food such as chicken wings, leg tips, and fish tails. See the “Aluminum Foil and Metal” section first.
- Times and cooking powers have been preset for defrosting a number of food types.

Item	Food Category	Weight
1	Meats*	0.2 to 6.6 lbs (90 g to 3 kg)
2	Poultry*	0.2 to 6.6 lbs (90 g to 3 kg)
3	Fish*	0.2 to 4.4 lbs (90 g to 2 kg)
4	Quick	1.0 lb only (450 g)

* See the Defrost Preparation Chart at end of the “Defrost” section for cuts, sizes, and instructions. Use the following chart as a guide when defrosting meat, poultry, or fish.

MEAT	
Beef: ground, steaks, roast, stew	The narrow or fatty areas of irregular-shaped cuts should be shielded with foil before defrosting.
Lamb: stew and chops	Do not defrost less than 1/4 lb (113 g) or two 4 oz (113 g) patties.
Pork: chops, ribs, roasts, sausage	Place all meats in a microwave-safe container.
POULTRY	
Chicken: whole and cut up	Place in a microwave safe container, chicken breast side up.
Cornish hens	Remove giblets from whole chicken.
Turkey: breast	
FISH	
Fillets, Steaks, Whole, Shellfish	Place in a microwave-safe container.

Reheat

Times and cooking powers have been preset for reheating a number of food types. Use the following chart as a guide.

Item	Food Category	Quantity
1	<p style="text-align: center;">Beverage</p> <p style="text-align: center;">Do not cover.</p>	1-2 cups (250 mL-500 mL)
2	<p style="text-align: center;">Casserole</p> <p style="text-align: center;">Place in microwave-safe container. Cover with plastic wrap and vent. Stir and let stand 2-3 minutes after reheating.</p>	1-4 cups (250 mL-1 L)
3	<p style="text-align: center;">Dinner plate</p> <p style="text-align: center;">Place food on plate. Cover with plastic wrap and vent. Let stand 2-3 minutes after reheating.</p>	1 plate, about 8-16 oz (227-454 g)
4	<p style="text-align: center;">Pizza</p> <p style="text-align: center;">Place on paper towel lined microwave-safe plate.</p>	1-3 slice, 4 oz (113 g) each
5	<p style="text-align: center;">Soup/Sauce</p> <p style="text-align: center;">Place in microwave-safe container. Cover with plastic wrap and vent. Stir and let stand 2-3 minutes after reheating.</p>	1-4 cups (250 mL-1 L)



Cook



Item	Food Category	Quantity
1	<p>Bacon</p> <p>Average thickness: Follow directions on package. For best results, place bacon on microwave-safe bacon rack.</p>	1-6 slices
2	<p>Canned Vegetable</p> <p>Place in microwave-safe container. Cover with plastic wrap, and vent. Stir and let stand 2-3 minutes after cooking.</p>	1, 2, 3 or 4 cups (250, 500, 750 mL or 1 L)
3	<p>Fresh Vegetable</p> <p>Place in microwave-safe container and add 2-4 tbs water. Cover with plastic wrap and vent. Stir and let stand 2-3 minutes after cooking.</p>	1-4 cups (250 mL-1 L)
4	<p>Frozen Vegetable</p> <p>Place in microwave-safe container and add 2-4 tbs water. Cover with plastic wrap and vent. Stir and let stand 2-3 minutes after cooking.</p>	1-4 cups (250 mL-1 L)
5	<p>Small Potatoes</p> <p>Pierce each potato several times with a fork. Place on paper towel, around turntable edges, at least 1" (2.5 cm) apart. Let stand 5 minutes after cooking.</p>	1-4 pieces, 4-7 oz (113-198 g)
6	<p>Large Potatoes</p> <p>Pierce each potato several times with a fork. Place on paper towel, around turntable edges, at least 1" (2.5 cm) apart. Let stand 5 minutes after cooking.</p>	1-4 pieces, 8-10 oz (227-283 g).
7	<p>Rice</p> <p>Follow measurements on package for ingredient amounts. Place rice and liquid in microwave-safe dish. Cover with loose fitting lid. Let stand 5 minutes after cooking, or until liquid is absorbed. Stir.</p>	0.5, 1.0, 1.5, 2.0 cups (125, 250, 375, 500 mL) (dry, white long grain)

Popcorn

3.0 or 3.5 oz bags.

- Do not use regular paper bags or glassware.
- Pop only one package of popcorn at a time.
- Follow manufacturer's instructions when using a microwave popcorn popper.
- Listen for popping to slow to one pop every 1 or 2 seconds, and then stop the cycle. Do not repop unpopped kernels.
- For best results, use fresh bags of popcorn.
- Cooking results may vary by brand and fat content.

NOTE: Follow the instructions provided by the microwave popcorn manufacturer.

Soften/Melt

Soften and Melt functions may be used to soften or melt your food. Times and cooking powers have been preset for a number of food types. Use the following chart as a guide.

Item	Food Category	Quantity	Preparation
1	Soften Butter	0.5, 1.0, 1.5, 2.0 sticks	Unwrap and place in microwave-safe container.
2	Soften Ice Cream	16, 32, or 64 oz (473, 946 or 1893 mL)	Place ice cream container on turntable.
3	Soften Cream Cheese	8 oz (227 g)	Unwrap and place in microwave-safe container.
4	Soften Frozen Juice	12 oz (340 g)	Remove lid.
5	Melt Butter	0.5, 1.0, 1.5, 2.0 sticks	Unwrap and place in microwave-safe container.
6	Melt Chocolate	4, 6, 8 or 12 oz (113, 170, 227 or 340 g)	Cut squares into small pieces or use chips. Place in microwavesafe container.
7	Melt Cheese	8 or 16 oz (227 or 454 g)	Cut into small pieces and place in microwave-safe container.
8	Melt Marshmallows	5 or 10 oz (142 or 283 g)	Place in microwavesafe container.

MICROWAVE OVEN CARE

General Cleaning

IMPORTANT: Before cleaning, make sure all controls are off and the microwave oven is cool. Always follow label instructions on cleaning products. Soap, water, and a soft cloth or sponge are suggested first, unless otherwise noted.

STAINLESS STEEL (on some models)

NOTE: To avoid damage to stainless steel surfaces, do not use soap filled scouring pads, abrasive cleaners, cooktop polishing creme, steel-wool pads, gritty washcloths, or abrasive paper towels. Damage may occur to stainless steel surfaces, even with one-time or limited use. Rub in direction of grain to avoid damaging.

Cleaning Method:

- Affresh® Stainless Steel Cleaners (not included): See the “Accessories” section.
- Vinegar for hard water spots.

MICROWAVE OVEN DOOR EXTERIOR

Cleaning Method:

- Glass cleaner and a soft cloth or sponge: Apply glass cleaner to soft cloth or sponge, not directly on panel.

MICROWAVE OVEN CAVITY

To avoid damage to microwave oven cavity, do not use soap filled scouring pads, abrasive cleaners, steel-wool pads, gritty washcloths, or some paper towels.

On stainless steel models, rub in direction of grain to avoid damaging the unit.

The area where the microwave oven door and frame touch when closed should be kept clean.

Cleaning Method:

Average soil

- Mild, nonabrasive soaps and detergents: Rinse with clean water and dry with soft, lint-free cloth.

Heavy soil

- Mild, nonabrasive soaps and detergents: Heat 1 cup (250 mL) of water for 2 to 5 minutes in microwave oven. Steam will soften soil. Rinse with clean water and dry with soft, lint-free cloth.

Odors

- Lemon juice or vinegar: Heat 1 cup (250 mL) of water with 1 tbs (15 mL) of either lemon juice or vinegar for 2 to 5 minutes in microwave oven.

TURNTABLE

Replace turntable immediately after cleaning. Do not operate the microwave oven without the turntable in place.

Cleaning Method:

- Mild soap and water
- Dishwasher

GREASE FILTERS

- Mild soap, water, and dishwasher clean is not recommended.

TURNTABLE SUPPORT AND ROLLERS, HUB

- Mild soap and water or dishwasher

NONSTICK CAVITY COATING (on some models)

- To avoid damage to the microwave oven cavity, do not use metal or sharp utensils or scrapers or any type of abrasive cleanser or scrubbers.

Installing / Replacing Grease Filter or Charcoal Filter

For recirculation only:

Do not operate the microwave oven without the charcoal filter in place.

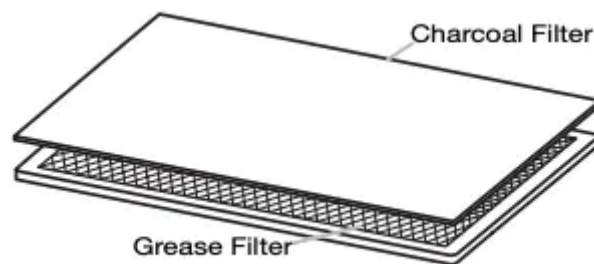

For Wall and Roof Ventilation:

To ensure good performance of airflow, remove the Charcoal Filter from the bottom plate before operating the microwave oven.

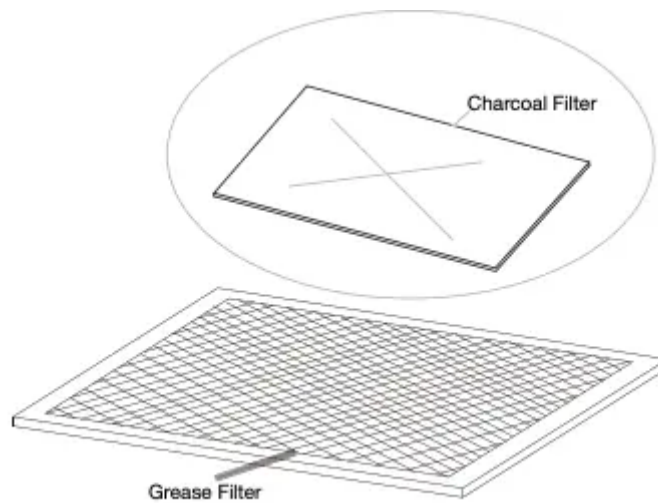

Replacing The Grease Filter For Recirculation Ventilation

Grease Filter:

The grease filter is located on the underside of the microwave oven. The grease filter should be removed and cleaned at least once a month.

1. To remove the grease filter, use a Phillips screwdriver to remove the screw on the grease filter.

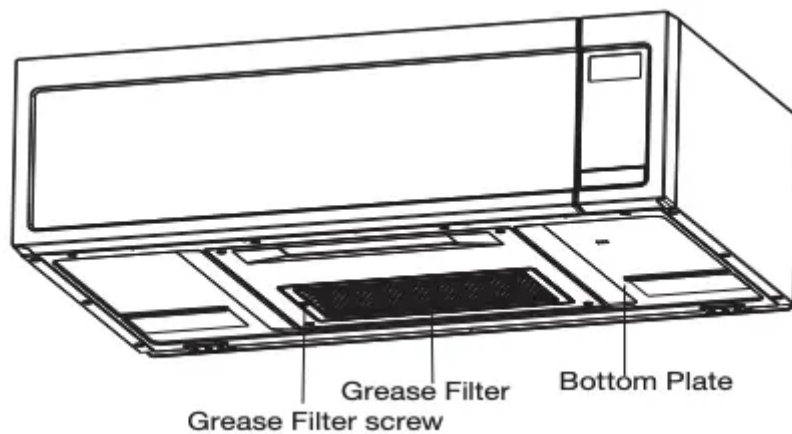

2. Hold the left side of the grease filter, swing it to the right position, and remove it from the slotted area.

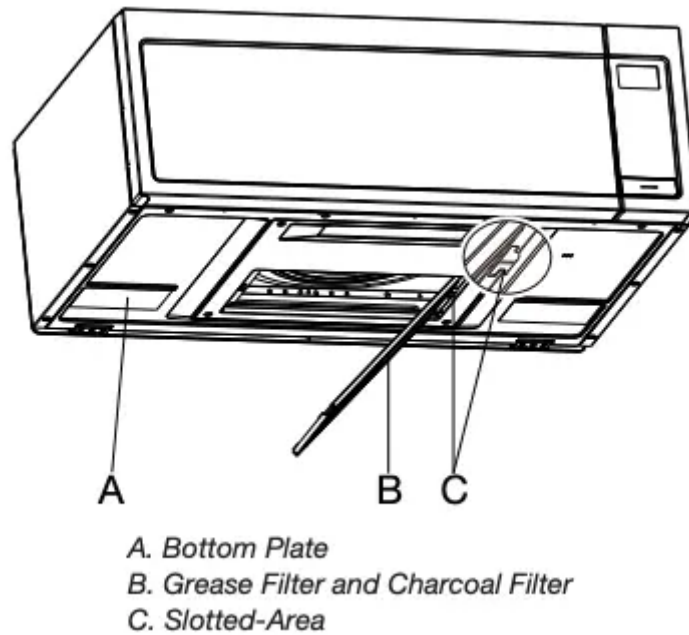

3. Separate the grease filter from the charcoal filter

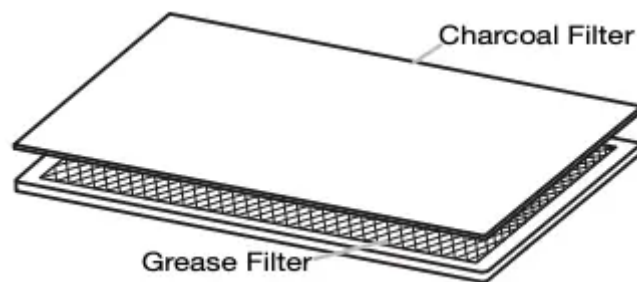

4. Clean the grease filter monthly, or replace with new grease filter if necessary.

5. Reattach the grease filter to the charcoal filter.

6. Put the grease filter and charcoal filter back to the bottom plate slotted area.

7. Secure the grease filter and charcoal filter back to the bottom plate with the grease filter screw.

Replacing The Charcoal Filter For Recirculation Ventilation

Charcoal Filter:

The charcoal filter is behind the grease filter at the bottom of the microwave oven. The charcoal filter cannot be cleaned and should be replaced about every 6 months. Repeat steps 1 to 3 from the “Replacing Grease Filter For Recirculation Ventilation”.

- 1. Replace the old charcoal filter with a new charcoal filter. Attach it to the grease filter.
- 2. Put the grease filter and the charcoal filter back to the bottom plate slotted area.
- 3. Secure the grease filter and the charcoal filter back to the bottom plate with the grease filter screw.

Replacing The Grease Filter For Wall and Roof Ventilation

Grease Filter: The grease filter is located on the underside of the microwave oven. The grease filter should be removed and cleaned at least once a month.

1. To remove the grease filter. Use a Phillips screwdriver to remove the screw on the grease filter.

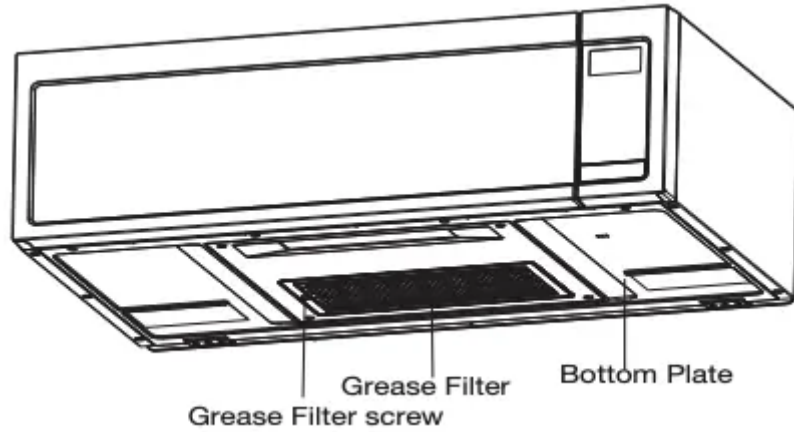

2. Hold the left side of the grease filter, swing it to the right position, and remove it from the slotted area.

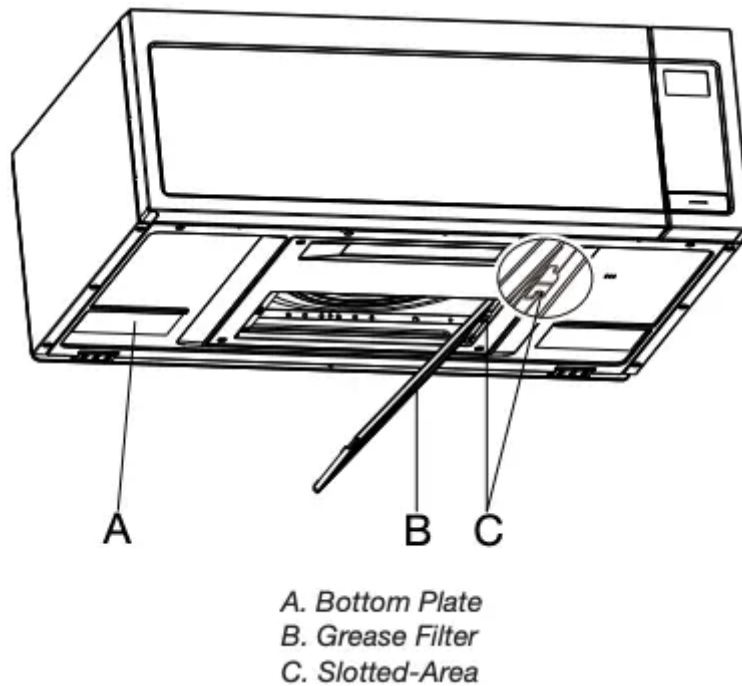

3. Clean the grease filter monthly, or replace it with new grease filter if necessary.
4. Reattach the grease filter to bottom plate.
5. Secure the grease filter back to the bottom plate with the grease filter screw.

Replacing The Cooktop Light

Cooktop Light: The Cooktop Light is located on the underside of microwave oven, behind the bottom light cover. It is replaceable. To replace the Cooktop Light refer the following steps:

1. Use a Phillips screwdriver to remove the 4 screws from the bottom light cover.

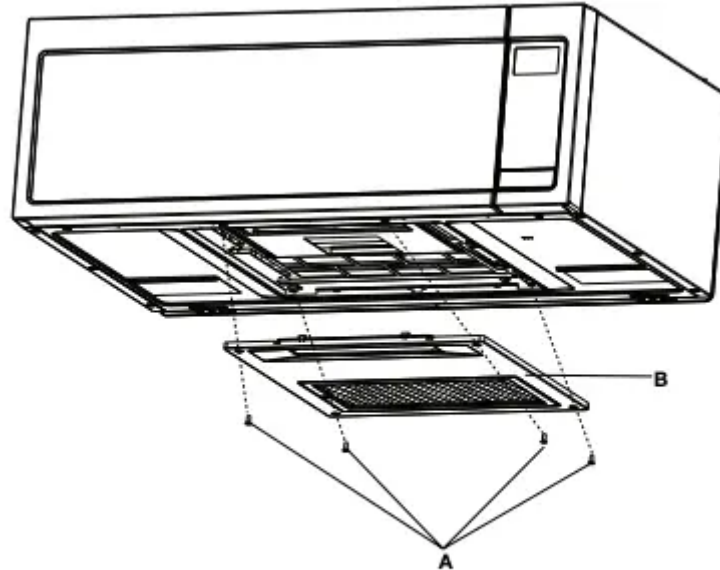

A. Screws
B. Bottom Light Cover

2. Push the 2 hooks backward and remove the LED.

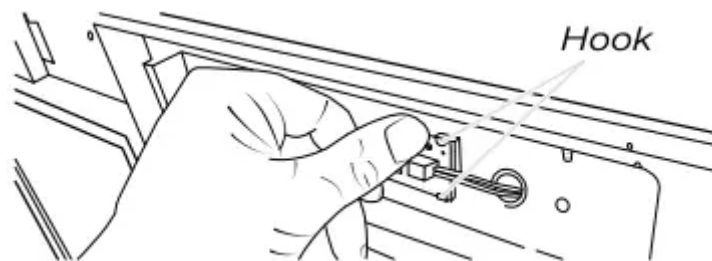

3. Unplug the terminal from the LED board.

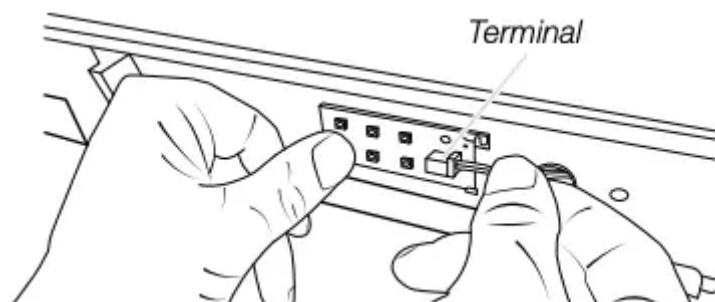

4. Replace the old LED with a new LED and press it back between two hooks and plug it into the terminal.

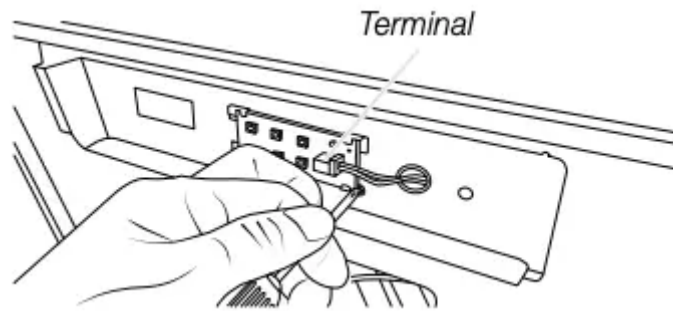

5. Use a Phillips screwdriver to reattach the 4 screws back to the bottom light cover.

Replacing The Cavity Light

Cavity Light: The Cavity Light is located at the top front of the microwave oven, under the cover and is replaceable. To replace the cavity light refer the following steps.

1. Use a Phillips screwdriver to remove the second left vent top cover screw from the top front of the microwave oven.

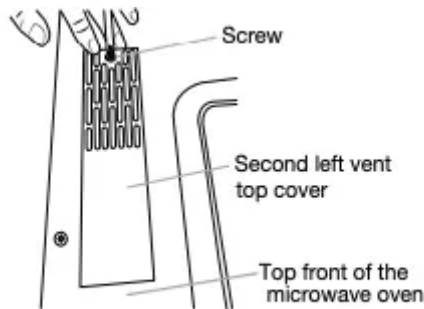

2. Remove the second left top cover.

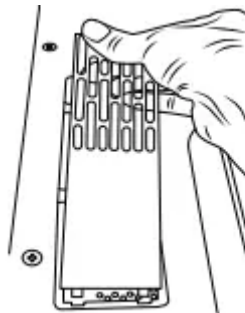

3. Pull out the halogen light from the light holder.
4. Insert the replacement halogen bulb.

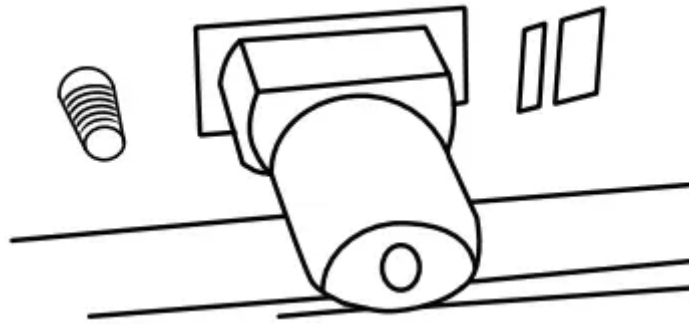

5. Reattach the second left top vent cover with the screw removed in step 1.

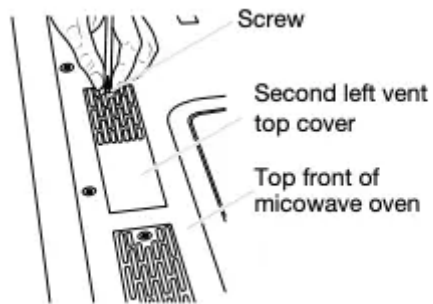

TROUBLESHOOTING

First try the solutions suggested here. If you need further assistance or more recommendations that may help you avoid a service call.

If you experience	Recommended Solutions
<p>Microwave oven will not operate</p>	<p>Check the following:</p> <ul style="list-style-type: none"> ■ Household fuse or circuit breaker: If a household fuse has blown or a circuit breaker has tripped, replace the fuse or reset the circuit breaker. If the problem continues, call an electrician. ■ Magnetron: Try to heat 1 cup (250 mL) of cold water for 2 minutes at 100% cooking power. If water does not heat, try the steps in the bullets below. If microwave oven still does not operate, call for service. ■ Door: Firmly close door. On some models, if a packaging spacer is attached to inside of the door, remove it, then firmly close door. If a message about the door appears in the display, the door has been closed for 5 minutes or more without the microwave oven being started. This occurs to avoid unintended starting of the microwave oven. Open and close the door, then start the cycle. ■ Control: Make sure control is set properly. Make sure Control Lock is off. Make sure Demo mode (on some models) is off.
<p>Arcing in the microwave oven.</p>	<p>Check the following:</p> <ul style="list-style-type: none"> ■ Soil buildup: Soil buildup on cavity walls, microwave inlet cover, cooking rack supports, and area where the door touches the frame can cause arcing. See “General Cleaning” in the “Microwave Oven Care” section.
<p>Turntable alternates rotation directions</p>	<ul style="list-style-type: none"> ■ This is normal and depends on motor rotation at the beginning of the cycle.
<p>Display shows messages</p>	<ul style="list-style-type: none"> ■ “:.” means there has been a power failure. Reset the clock. ■ A letter followed by a number is an error indicator. Call for assistance.
<p>Fan running during cooktop usage</p>	<p>This is normal. The microwave oven’s vent fan automatically comes on during microwave oven operation to cool the microwave oven. It may also automatically come on and cycle on and off to cool the microwave oven’s controls while the cooktop below is being used.</p>
<p>Radio, TV, or cordless phone interference</p>	<p>Check the following:</p> <ul style="list-style-type: none"> ■ Proximity: Move the receiver away from the microwave oven, or adjust the radio or TV antenna.



- Soil: Make sure the microwave oven door and sealing surfaces are clean.
- Frequency: Some 2.4 GHz based cordless phones and home wireless networks may experience static or noise while microwave oven is on. Use a corded phone, a different frequency cordless phone, or avoid using these items during microwave oven operation.

Warning

This content is compiled from multiple sources and is provided for reference purposes only. It may not be complete or fully applicable to all situations. If you are unable to resolve your issue, please contact the product manufacturer or an authorized service provider for official support.