

INSTRUCTION FOR USE Food Processor

THE PARTS

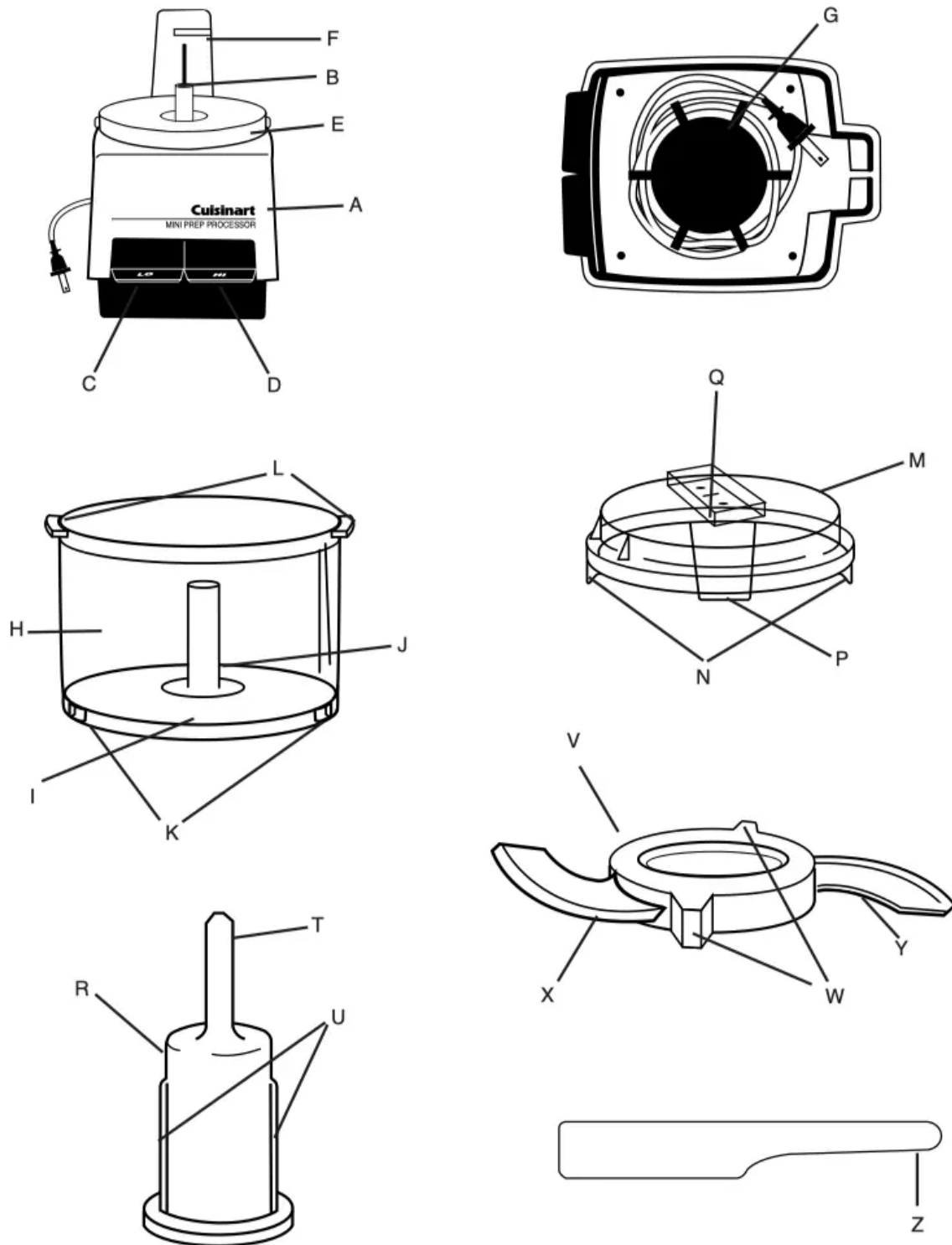

- A. Compact Motor Base, with:
- B. Shaft from motor
- C. LO Speed-Control lever



- D. HI Speed-Control lever
 - E. Round bowl-support platform with two locking tabs
 - F. Column at back with interlock slot
 - G. Power cord with concealed storage underneath
 - H. Prep Bowl, with:
 - I. Prep Bowl part number
 - J. Central Opening
 - K. Two openings for locking tabs on lower surface of motor base
 - L. Two tabs on opposite sides of top surface
 - M. Prep Bowl Cover, with:
 - N. Tabs on opposite sides
 - P. Long descending tab at back
 - Q. Handle on top with two openings for adding liquids
 - R. Plastic Sheath, with:
 - T. Handle on top
 - U. Ridges along opposite sides
 - V. Blade Assembly, with:
 - W. Central hub holding ribs (grips)
 - X. Curved sharp edge
 - Y. Flat blunt edge
- BLADE IS VERY SHARP. ALWAYS HANDLE IT BY CENTRAL HUB. NEVER TOUCH THE BLADE ITSELF.
- Z. Spatula

ASSEMBLING THE PARTS

Before you process any food, assemble the parts and try the HI and LO processing speeds to get a feel for how your Mini-Prep® Processor works.

1. Place the Motor Base on a flat, dry, stable surface. It should be close to an electrical outlet of the same voltage as that stated on the bottom of the unit.
2. Locate part number on bottom of Prep Bowl. Place the Prep Bowl on the motor base with the Prep Bowl part number slightly to the left of center, then rotate it counterclockwise until it

locks and clicks into position. Rotate Prep Bowl following direction of Bowl Lock arrows printed on motor base.

3. Connect the Blade Assembly to the Blade Sheath. HOLD THE BLADE ASSEMBLY BY THE CENTRAL HUB HOLDING RIBS (grips) ONLY. DO NOT TOUCH THE RAZOR-SHARP BLADES.

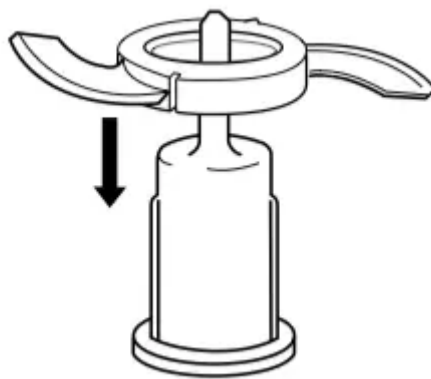

Note these important features of the Blade Assembly.

- The Assembly can be placed over the Sheath in two different ways.

If you hold it this way (A), you will see the word "Sharp" on the blade. Assemble the blade this side up to use the sharp edge. (See the section on processing food for information about when to use the sharp edge.)



If you hold it this way (B), you will see no writing on the blade. Assemble the blade this side up to use the blunt edge. (See the section on processing food for information about when to use the blunt edge.)

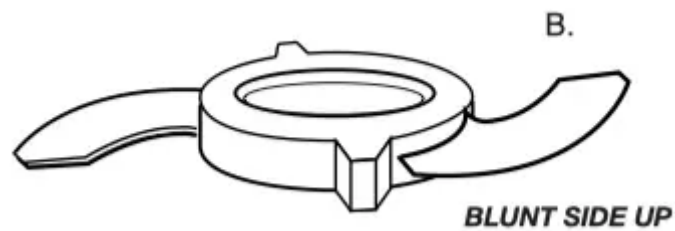

- There are notches (C) on opposite sides of the interior of the hub. These fit over ridges on the sides of the Sheath.

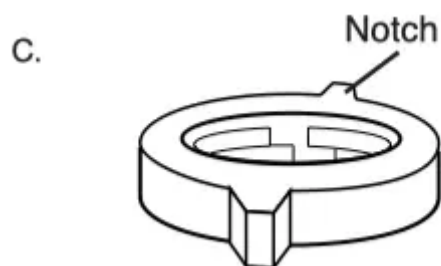

Place the Sheath, handle side up, on a flat surface. Pick up the Blade Assembly by its hub holding ribs (grips) and line up the notches in the interior of the hub with the ridges on the sides of the Sheath. Let the Blade Assembly slide down to the bottom of the Sheath.

Lift the Sheath by its handle. Hold the Blade Assembly by its hub holding ribs (grips) and turn it very slightly clockwise. This locks it in place on the Sheath and prevents it from sliding up during processing.

4. Hold the Sheath by its top handle, place it over the central opening of the Bowl, and slide the Sheath down over the motor shaft. The lower blade on the Blade Assembly should almost touch the bottom of the Prep Bowl.

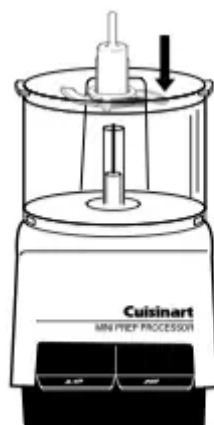

5. Hold the cover by its handle on the top, with the descending tab in about the 2 o'clock position (D).



While holding the Motor Base, press the cover onto the Prep Bowl. Use the handle to turn it counterclockwise until the descending tab on the back locks into the slot on the column of the Motor Base. IF THE TAB DOES NOT FULLY OR COMPLETELY ENGAGE IN THE SLOT, THE MOTOR WILL NOT START.

6. Plug the cord into an electrical outlet.

7. Place one hand on the cover of the unit, and press the LO Speed-Control Lever with the thumb or forefinger of your other hand. Remove your thumb or finger from the control.

8. Now press and release the HI SpeedControl Lever.

9. WHEN THE BLADE STOPS MOVING, remove the cover by turning it gently clockwise and lifting it straight up.



10. Now you are ready to process food.

11. Disassembling the Blade Assembly Lift the Sheath. Holding the Blade Assembly stationary, carefully turn the Sheath Cylinder clockwise, then guide the Blade Assembly up over the Sheath.

TIPS FOR PROCESSING FOOD

Preparing the Food

Size:

Always cut large pieces of food into smaller pieces of even size – about 1/2 inch (12mm) to a side. If you don't start with pieces that are small and uniform, you will not get an even chop.

Quantity:

Do not overload the Prep Bowl. Overloading causes inconsistent results and it strains the motor. Use the quantities given in the recipe section as a guide. As a rule of thumb, remember that after being processed, food should not reach more than 2/3 of the way up the Sheath of the Blade Assembly.

Selecting the Right Blade Edge

Use the sharp edge for chopping, puréeing and mixing. It is the right choice, for example, for chopping soft, fragile food such as herbs, celery, onions, garlic and most cheese. It is also the right choice for puréeing cooked vegetables, making mayonnaise and mixing salad dressing.

Use the blunt edge for grinding coffee beans and spices, and for chopping hard food such as peppercorns, seeds, chocolate and nuts.

Selecting the Right Operating Speed

Use low speed (LO Lever) for chopping, puréeing, and mixing food with the sharp edge of the blade.

Use high speed (HI Lever) for grinding and for chopping hard food with the blunt edge of the blade.

Note: Due to the powerful motor provided with this unit, Cuisinart recommends using one hand to support the Mini-Prep ® during operation. This is especially true of the Hi speed.

Selecting the Right Lever Action

Pulse action is best when you are using the sharp edge of the blade. Two or three pulses are often enough. Be sure to check the food frequently to prevent overprocessing. If you overprocess, you are likely to get a watery paste instead of a fine chop.

Continuous-hold action is best when you are using the blunt edge of the blade. You may have to operate the Mini-Prep ® Processor for several seconds to achieve the desired results with some food - as long as 20 seconds for some seeds, or 40 seconds for coffee beans.

When you operate the unit for more than 10 seconds, use a pulse action every 10 seconds or so to allow food to drop to the bottom of the Prep Bowl. This provides more consistent results.

Never operate the Mini-Prep ® continuously for longer than 1 minute at a time.

Note: The Prep Bowl and Cover may become scratched when you use them for grinding coffee, grain and spices. This does not affect the performance of the Mini-Prep® Processor. However, you may want to reserve that bowl for grinding, and purchase an additional bowl and cover set for other uses. These are available from the Cuisinart® Customer Service Department, which you can reach by dialing our toll-free number: 800-726-0190. Ask for Model DLC-195A when ordering.

Summary: Selecting Blade, Speed, and Lever Action

Operation	Blade Edge	Speed	Lever Action
Chopping Grinding	Sharp Blunt	LO HI	Pulse Continuous

Adding Liquid

You can add liquids such as water, oil or flavoring while the machine is running. You might want to add oil when making mayonnaise or salad dressing, for example. Or you could add vanilla or alcohol when making frozen yogurt.

Pour the liquid through one of the two openings in the cover. **IMPORTANT:** Add liquid through only one opening at a time. The other opening must be left free for air to escape. If both openings are blocked, liquid cannot flow smoothly into the bowl.

Removing Food from the Sides of the Bowl

Occasionally food will stick to the sides of the bowl as you process. Stop the machine to clear it away. **AFTER THE BLADE HAS STOPPED MOVING**, remove the cover, and use the spatula to scrape the food from the sides of the bowl back into the center.

Reversing the Blade in the Middle of a Processing Task

While preparing some recipes, you may want to switch the blade from sharp to blunt or vice versa.

1. Be sure neither of the Control Levers is pressed down.
2. Unplug the unit.
3. Remove the cover from the Prep Bowl.
4. Lift the Sheath by its top handle and remove the Blade Assembly. **NEVER TOUCH THE BLADE ITSELF.**
5. Remove the contents of the bowl to another container.
6. Carefully remove the Blade Assembly, holding it by its Hub Holding Ribs. Turn blade upside-down and reinsert it on the Sheath.
7. Insert the Sheath over the central opening of the empty bowl.
8. Insert the food to be processed.

9. Replace the cover, locking it into place.
10. Plug the unit into the electrical outlet and continue processing.

PROCESSING FOOD

1. Place the Prep Bowl firmly on the motor base and insert the Blade Assembly. Be sure the blade is assembled to use the blade edge that is appropriate for the food to be processed.
2. Place food in the Prep Bowl. Be sure the food is cut in small pieces, and the bowl is not overloaded.
3. Lock the Cover into position.

Note: Due to the powerful motor provided with this unit, Cuisinart recommends using one hand to support the Mini-Prep ® during operation.

4. Press the appropriate SpeedControl Lever – LO or HI, depending on the food you are processing.
5. When you have finished processing the food, stop the machine by releasing the Speed-Control Lever.
6. WHEN THE BLADE STOPS MOVING, remove the Cover.
- 6a. Unplug the unit.
7. Carefully remove the Blade Assembly, holding it by the handle on the top of the Sheath. NEVER TOUCH THE BLADE ITSELF.
8. Remove food with the spatula.

Note: Do not operate Mini-Prep ® without food contents in Prep Bowl.

OPERATING TECHNIQUES

Chop, grind and purée small amounts of food with the Mini-Prep ® Processor. This table lists a number of ingredients in alphabetical order, and shows the recommended method of processing for each.

Ingredient:	Blade Position/Speed		Comments
	Sharp/LO	Blunt/HI	
anchovies	X		must be cooked crisp
bacon	X		
butter	X		
celery	X		
cheese hard*		X	chop no more than 2 ounces (56g) at one time
semi-hard	X		must be chilled must be well chilled
semi-soft	Sharp/HI		
soft	X		
chocolate			chop no more than 1 ounce (28g) at a time better results if chilled/refrigerated
bittersweet		X	
milk chocolate		X	
cinnamon sticks		X	grind no more than 1/2 cup (2 oz., 56g) at a time
coffee beans		X	
fruit chips		X	
garlic	X		
ginger root	X		X
grain		X	
green onions	X		must be brittle, like Italian amaretti meats should be cold but not frozen or precooked
herbs, fresh	X		
horseradish	X		
leeks	X		
macaroons	X		
meats	X		
mushrooms	X		
nutmeg		X	
nuts		X	
olives	X		
onions	X		
peel, citrus	X		
peppercorns		X	
peppers, dried	X		like coriander, dill, cumin, poppy, etc.
peppers, fresh	X		
scallions	X		
seeds		X	
shallots	X		cook until soft, process to a smooth purée
vegetables, cooked	Sharp/HI		

*If cheese is fresh and slightly crumbly, use the SHARP edge. (Use the BLUNT edge for extremely hard, imported or older cheeses only. Many cheeses available are actually only semi-hard.)

TROUBLESHOOTING

Motor doesn't start or blade doesn't rotate.

- Check that plug is securely inserted into outlet.
- Check that Prep Bowl and cover are securely locked into place.

- Be sure to press only one speedcontrol lever at a time.

Food is unevenly chopped.

- Either you are chopping too much food at one time, or the pieces are not small enough. Try cutting food into smaller pieces of even size and processing a smaller amount per batch.

Food is chopped too fine or is watery.

- The food is overprocessed. Use brief pulses, or process for less time.

Food collects on Prep Bowl cover or sides of Prep Bowl.

- You may be processing too much food. Turn machine off. When blade stops rotating, remove cover, and clean bowl and lid with spatula.

Food hangs up on blade.

- You may be processing too much food. Carefully remove blade. Remove food from blade with spatula, and start over again.

CLEANING AND STORAGE

To simplify cleaning, rinse the Prep Bowl, cover and blade immediately after use, so that food won't dry onto them. Wash Blade Assembly, Sheath, Prep Bowl, cover and spatula in warm soapy water. Rinse and dry. Wash the blade carefully.

Avoid leaving it in soapy water where it may disappear from sight.

If you have a dishwasher, you can wash the Prep Bowl, cover, Blade Assembly and spatula on the upper shelf. Insert the Prep Bowl upside-down and the cover right-side up. Put the blade and spatula in the cutlery basket. Unload the dishwasher carefully to avoid contact with the sharp blade. Wipe the motor base clean with a damp sponge or cloth. Dry it immediately. Never submerge the motor base or the plug in water or other liquid.

The Mini-Prep® stores neatly on the countertop in a minimum of space. When it is not in use, be sure to leave it unplugged. The hidden cord storage underneath the motor base will help to keep excess cord off the countertop. Store the unit assembled to prevent loss of parts. Store the blades as you would sharp knives—out of the reach of children.

The Mini-Prep® is intended for HOUSE-HOLD USE ONLY. Any service other than cleaning and normal user maintenance, should be performed by an authorized Cuisinart® Service Representative.

Warning

This content is compiled from multiple sources and is provided for reference purposes only. It may not be complete or fully applicable to all situations. If you are unable to resolve your issue, please contact the product manufacturer or an authorized service provider for official support.

Document generated by [ManualsFile](#)

