

Knowing your sewing machine

Names of machine parts and their functions

The main parts

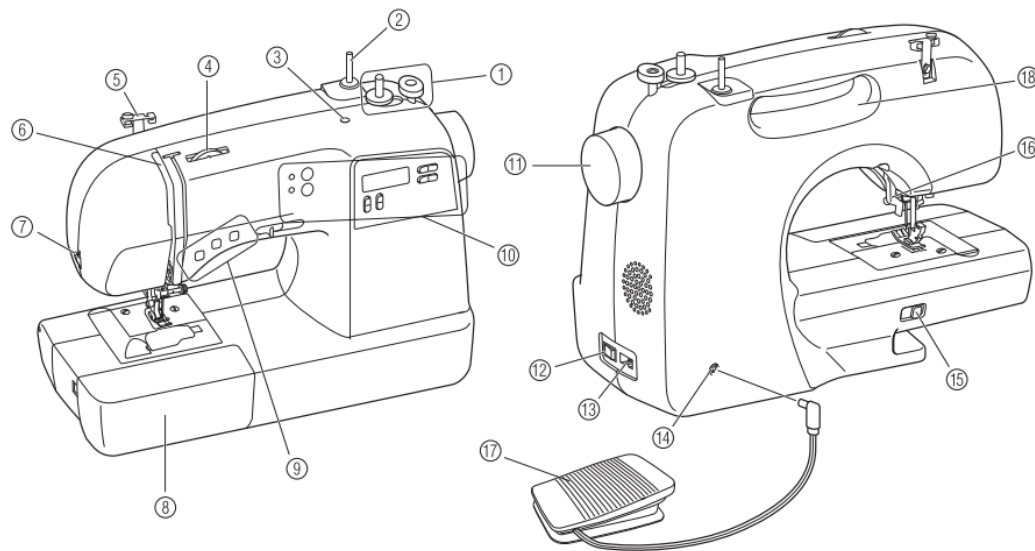

1. Bobbin winder

This winds the thread onto the bobbin for use as the lower thread.

2. Spool pin

This holds the spool of thread.

3. Hole for extra spool pin

This holds a second spool of thread for sewing with two needles. Not for lubrication.

4. Upper tension-control dial

This controls the tension of the upper thread.

5. Thread guide

This is used when winding the thread onto the bobbin and then threading the machine.

6. Thread take-up lever

7. Thread cutter

Pass the threads through the thread cutter to cut them.

8. Flat bed attachment with accessory compartment

9. Operation buttons

The operation buttons differ depending on the sewing machine model.

10. Operation panel

This is used to select the stitch and specify the various settings.

11. Handwheel

Used to manually raise and lower the needle.

12. Main power and sewing light switch

You can turn the main power and sewing light switch on and off.

13. Jack/socket connector

Insert the plug on the power supply cord into the jack/ socket connector.

14. Foot controller jack/socket

Plug in the foot controller plug.

15. Feed dog position lever

Use the feed dog position lever to lower the feed dogs.

16. Presser foot lever

Used to raise and lower the presser foot.

17. Foot controller

You can use this to control the sewing speed, and to start and stop sewing.

18. Handle

Carry the sewing machine by its handle when transporting the machine.



Needle and presser foot section

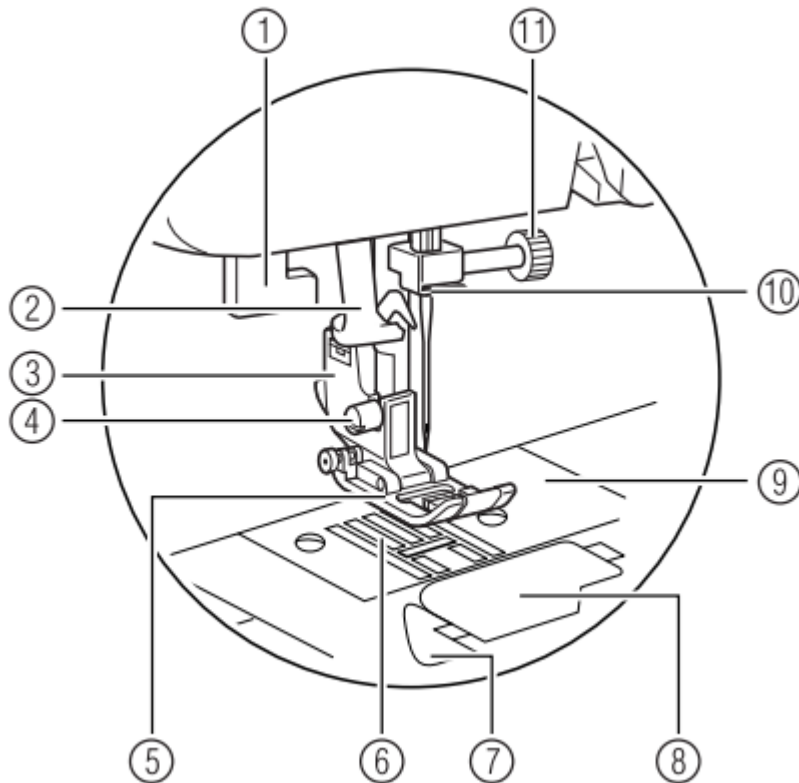

1. Buttonhole lever

Lower the buttonhole lever when sewing buttonholes and bar tacks.

2. Needle threader (for models equipped with the needle threader)

3. Presser foot holder

The presser foot is installed onto the presser foot holder.

4. Presser foot holder screw

Use the presser foot holder screw to hold the presser foot holder in place.

5. Presser foot

The presser foot applies pressure consistently on the fabric as the sewing takes place. Attach the appropriate presser foot for the selected stitching.

6. Feed dogs

The feed dogs feed the fabric in the sewing direction.

7. Quick-set bobbin (for models equipped with the quick- set bobbin)

You can start sewing without pulling up the bobbin thread.

8. Bobbin cover

Open the bobbin cover to set the bobbin.

9. Needle plate

The needle plate is marked with guides for sewing straight seams.

10. Needle bar thread guide

Pass the upper thread through the needle bar thread guide.

11. Needle clamp screw

Use the needle clamp screw to hold the needle in place

Operation buttons

The operation buttons help you to easily perform various basic sewing machine operations.

The operation buttons differ depending on the sewing machine model.

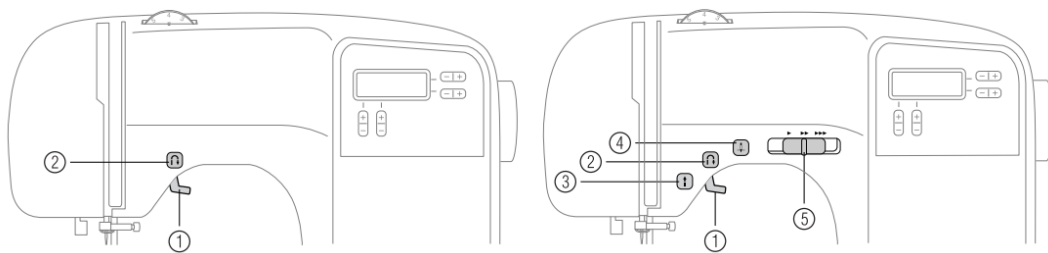

1. Presser foot lever

Raise and lower the presser foot lever to raise and lower the presser foot.

2. Reverse/reinforcement stitch button

Press the reverse/reinforcement stitch button to sew reverse stitches. Reverse stitches are sewn by keeping the button pressed down to sew in the opposite direction. For details, refer to “Sewing reinforcement stitches

Buttons provided on some models

3. Start/stop button (for models equipped with the start/stop button)

Press the start/stop button to start or stop sewing. The machine sews at a slow speed at the beginning of sewing while the button is depressed. When sewing is stopped, the needle is lowered in the fabric. For details, refer to “Starting to sew” (page 29).

4. Needle position button (for models equipped with the needle position button)

Press the needle position button to raise or lower the needle. Pressing the button twice sews one stitch.

5. Sewing speed controller (for models equipped with the sewing speed controller)

Slide the sewing speed controller to adjust the sewing speed.

Operation panel

The operation panel, located on the front of the sewing machine, allows you to select a stitch and specify how the stitch will be sewn.

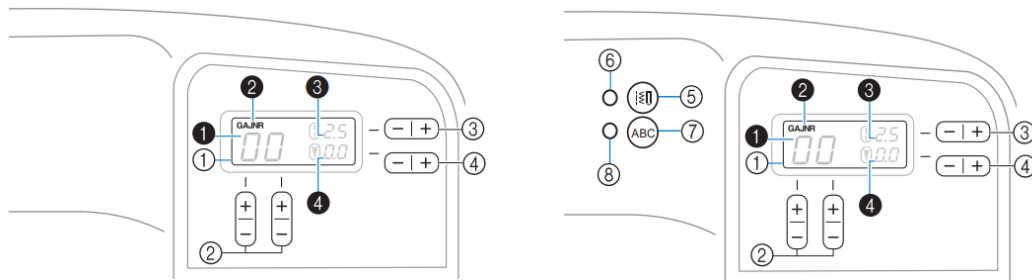

1. LCD (liquid crystal display)

The number of the selected stitch (1), the presser foot to be used (2), the stitch length (mm) (3), and the stitch width (mm) (4) are displayed here.

2. Stitch selection keys

Press the stitch selection keys, and then select the number for the stitch that you wish to use. For details, refer to “Selecting a stitch” {page 28}.

3. Stitch length adjustment key

Press this key to adjust the stitch length.

(For models equipped with the character stitch key)

Press this key to check the combined characters. For details, refer to “Checking characters” {page 66}.

4. Stitch width adjustment key

Press this key to adjust the stitch width.

(For models equipped with the character stitch key)

Press this key to add or delete characters. For details, refer to “SEWING CHARACTERS (for models equipped with character stitches)” (page 64).

Keys and indicators provided on some models

5. Utility stitch key

Press this key to sew utility stitches. For details, refer to “Selecting a stitch” (page 28) .

6. Utility stitch indicator

This indicator lights up when the utility stitch key is pressed.

7. Character stitch key

Press this key to sew character stitches. For details, refer to “SEWING CHARACTERS (for models equipped with character stitches)” (page 64).

8. Character stitch indicator

This indicator lights up when the character stitch key is pressed.

Flat bed attachment

The accessories are stored in a compartment inside the flat bed attachment.

1. Slide the flat bed attachment to the left to open it.

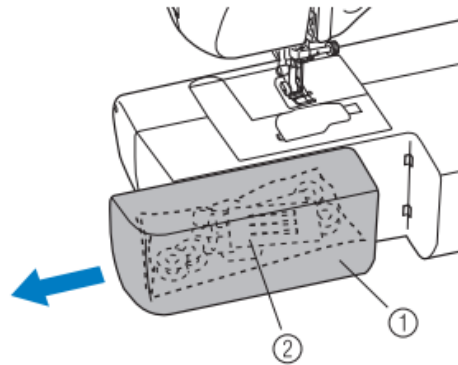

- ① Flat bed attachment
- ② Storage compartment

USING YOUR SEWING MACHINE

Turning on the machine

1. Insert the plug into a wall outlet.

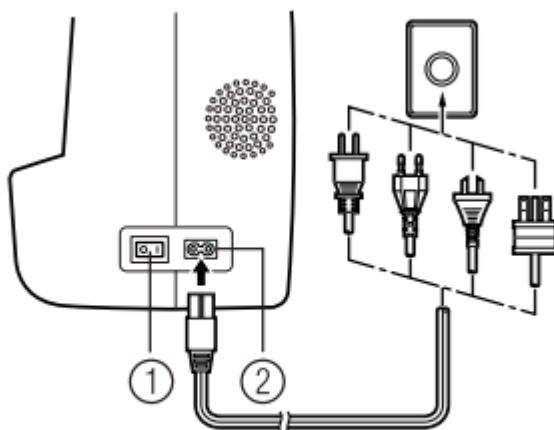

- ① Main power switch
- ② Jack/socket connector

2. Set the main power switch to “I”

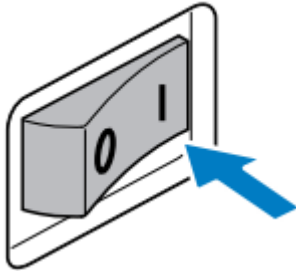

- The sewing lamp comes on when the machine is turned on.

3. To turn off the machine, set the main power switch to “**0**”.

- The sewing lamp goes off when the machine is turned off.

Foot controller

Insert the foot controller plug into its jack/socket on the rear side of the sewing machine.

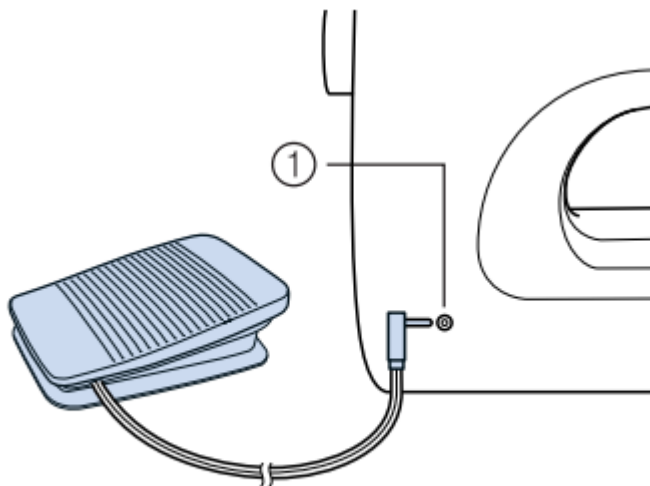

① Foot controller jack/socket

When you press the foot controller down lightly, the machine will run at a low speed. When you press harder, the machine's speed will increase. When you take your foot off the foot controller, the machine will stop.

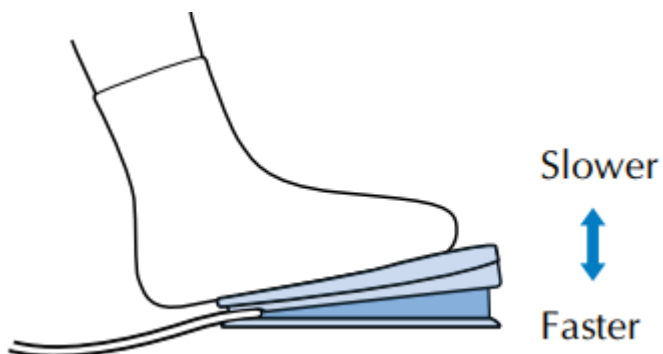

You should make sure that nothing is placed on the foot controller when the machine is not in use.

Sewing speed controller(for models equipped with the sewing speed controller)

1. Slide the sewing speed controller to the left or right to select the desired sewing speed.

Slide the sewing speed controller to the left to sew at a slower speed, or slide the speed controller to the right to sew at a faster speed.

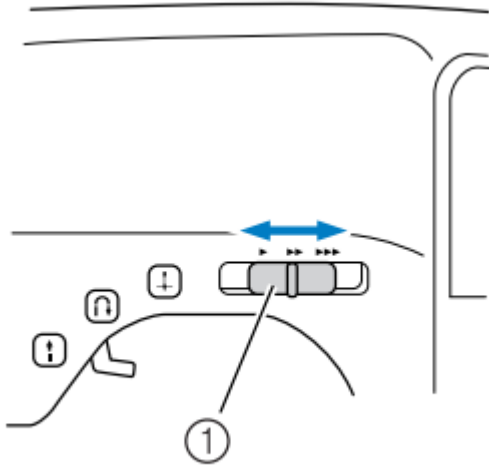

① Sewing speed controller

- The speed set using the sewing speed controller is the foot controller's maximum sewing speed.

Changing the needle stop position

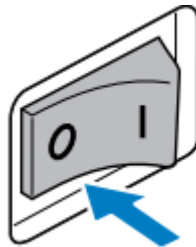

Normally, the sewing machine is set to leave the needle in the fabric when sewing is stopped. Instead, the machine can be set to leave the needle raised when sewing is stopped.

1.



Turn off the sewing machine.

2.

Hold down the “~” side of  (stitch selection key) on the left and turn on the sewing machine. After turning on the sewing machine, release the “~” side of  (stitch selection key).

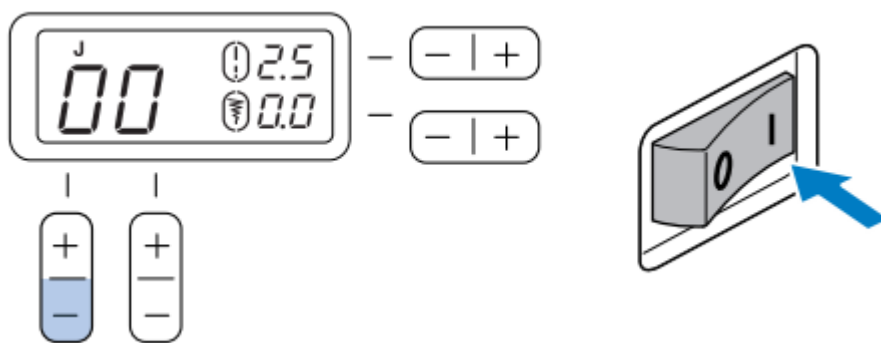



- The needle stop position changes to the raised position.

Changing the initial needle position

Normally, the straight stitch (left needle position) is automatically selected when the sewing machine is turned on. The machine can be set so that the straight stitch (center needle position) is automatically selected when it is turned on.

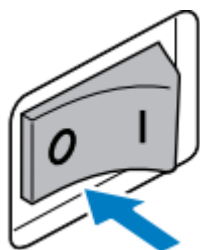
1. Turn off the sewing machine.



2. Hold down the "+" side of  (stitch selection key) on the left and turn on the sewing machine.

After turning on the sewing machine, release the "+" side of  (stitch selection key).

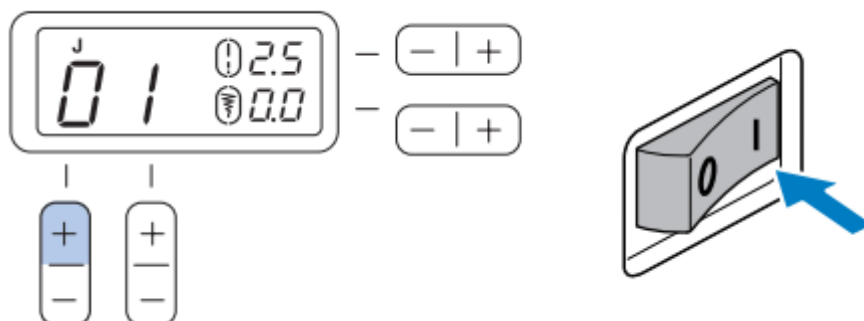



- The initial needle position changes to the center needle position.

Cancelling the operation beep (for models equipped with the operation beep)

When the sewing machine is purchased, it is set to beep each time a key is pressed. This setting can be changed so that the machine does not beep.

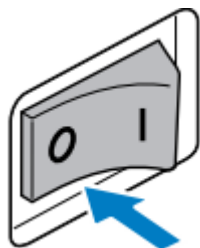
1. Turn off the sewing machine.



2. Hold down the “—” side of  (stitch width adjustment key) and turn on the sewing machine.

After turning on the sewing machine, release the “-” side of  (stitch width adjustment key).

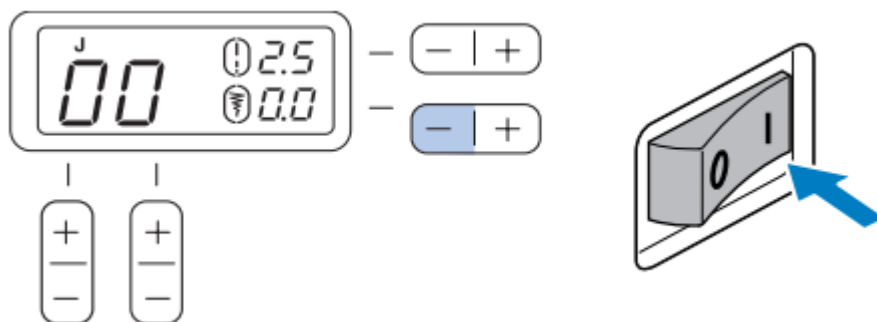

- The machine is now set so that it will not beep.

THREADING THE MACHINE

Winding the bobbin

This section describes how to wind the thread onto the bobbin.

- For details on the fast bobbin winding, see page 14.

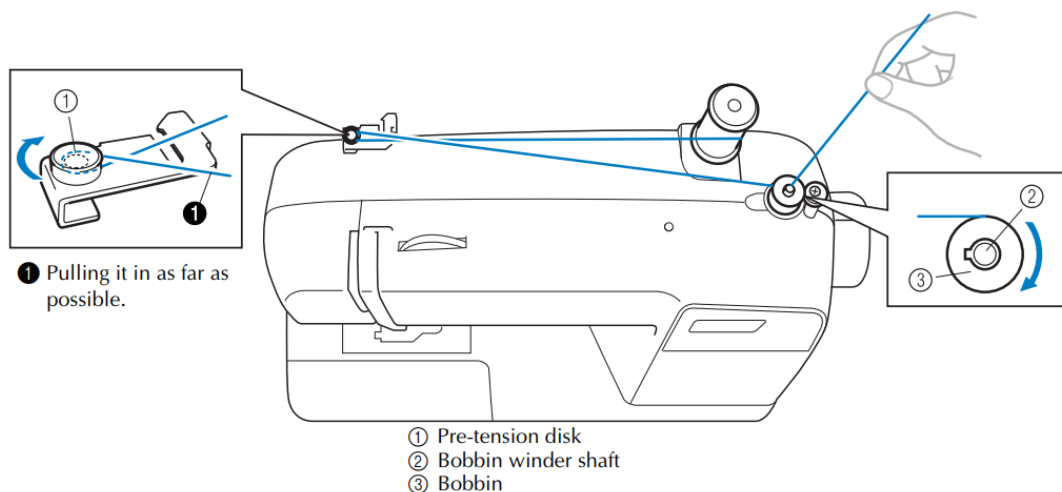

1. Pull up the spool pin as far as possible, and then put a spool of thread on this pin.
2. Pass the thread around the pre-tension disk.
3. Pass the end of the thread through the hole on the bobbin from the inside of the bobbin.
4. Put the bobbin onto the bobbin winder shaft and slide the bobbin winder shaft to the right. Turn the bobbin clockwise, by hand, until the spring on the shaft slides into the groove of the bobbin.

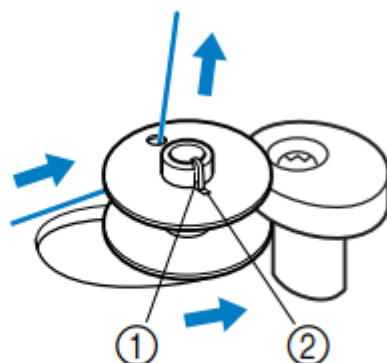

- ① Spring on the shaft
- ② Groove of the bobbin

5. Turn on the sewing machine.

6. While holding the end of the thread, gently press the foot controller or press  (start/ stop button) (for models equipped with the start/stop button) to wind the thread around the bobbin a few times. Then stop the machine.

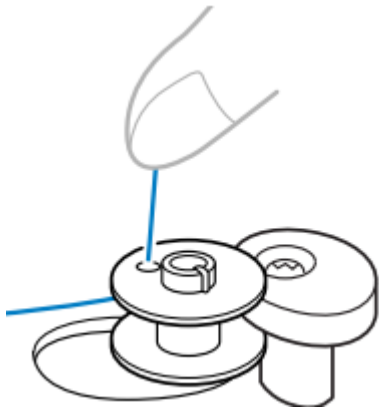

7. Trim the excess thread above the bobbin.

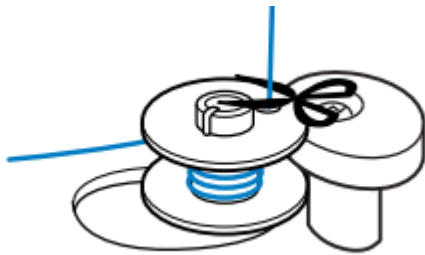

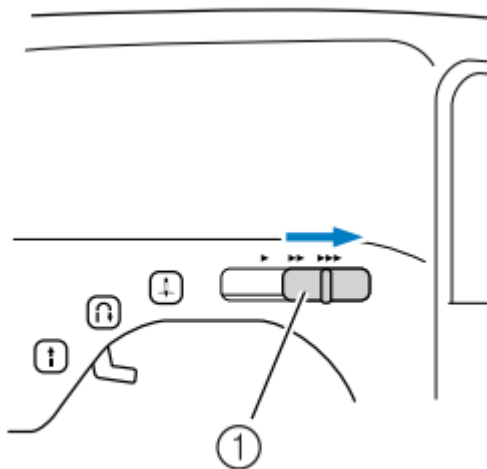

8. Slide the sewing speed controller to the right (to set the speed to fast) (for models equipped with the sewing speed controller).

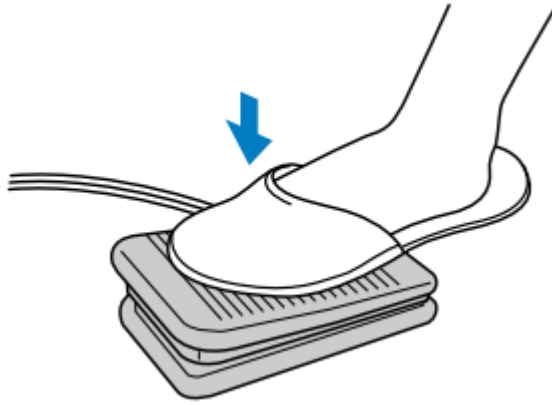

① Sewing speed controller

9. Press the foot controller or press  (start/ stop button) (for models equipped with the start/ stop button) to start.



10. When the bobbin seems full and begins spinning slowly, take your foot off the foot controller or press  (start/stop button) (for models equipped with the start/stop button).
11. Cut the thread, slide the bobbin winder shaft to the left and remove the bobbin.
12. Slide the sewing speed controller back to its original position (for models equipped with the sewing speed controller).

Lower threading

Install the bobbin wound with thread.

1. Raise the needle to its highest position by turning the handwheel toward you (counterclockwise) or press  (needle position button) (for models equipped with the needle position button), and raise the presser foot lever.
2. Slide the button and open the cover.

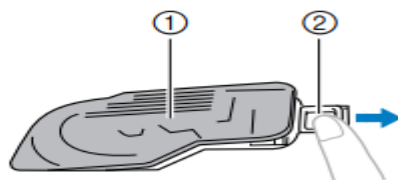

- ① Cover
- ② Slide button

3. Put the bobbin in, feed the end of the thread through the slit, and then pull the thread to cut it.

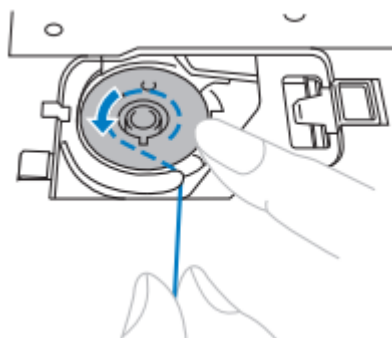

- Only use bobbins that were designed to be used with this machine.

4. Hold the end of the thread, push the bobbin down with your finger, and then pass the thread through the slit, as shown.

- If the thread is not correctly inserted through the tension-adjusting spring of the bobbin case, it may cause incorrect thread tension

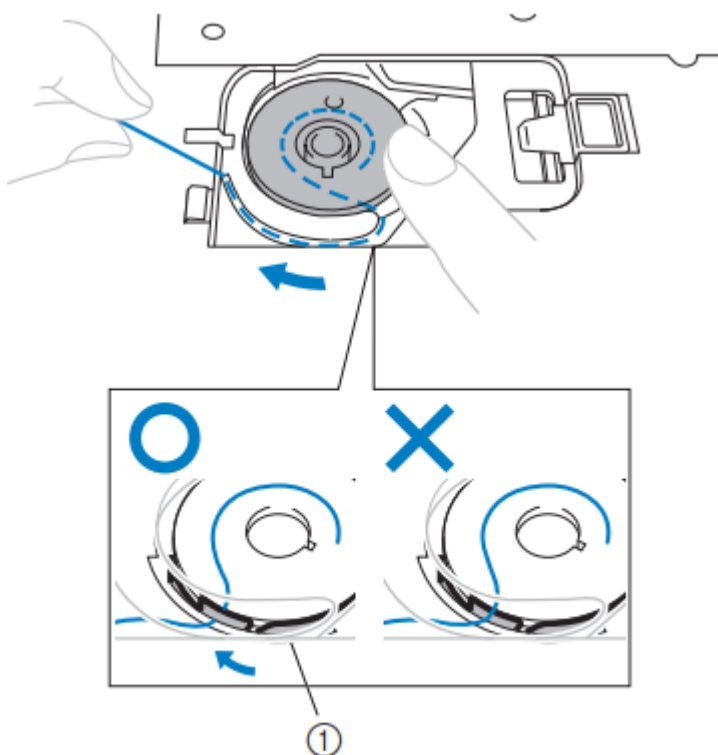

① Tension-adjusting spring

5. Replace the bobbin cover. Put the left tab in place (see arrow (1), and then press lightly on the right side (see arrow (2) until the cover clicks into place.

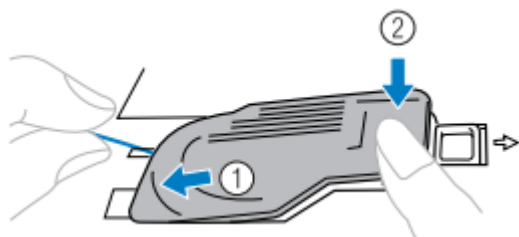

- Replace the cover so that the end of the thread comes out from the left side of the cover (as shown by the line in the diagram).

Upper threading

Set the upper thread and thread the needle.

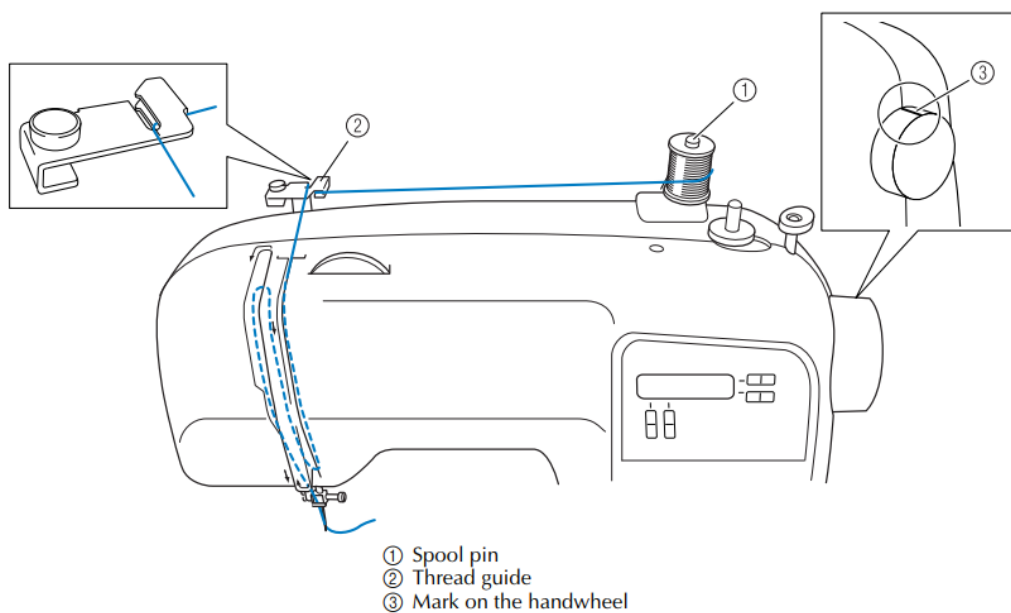

1. Raise the presser foot using the presser foot lever.

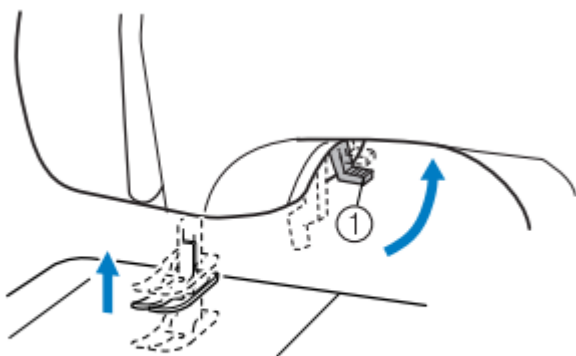

① Presser foot lever

2. Raise the needle by turning the handwheel toward you (counterclockwise) so that the mark on the wheel points up, or press (needle position button) (for models equipped with the needle position button) once or twice to raise the needle.

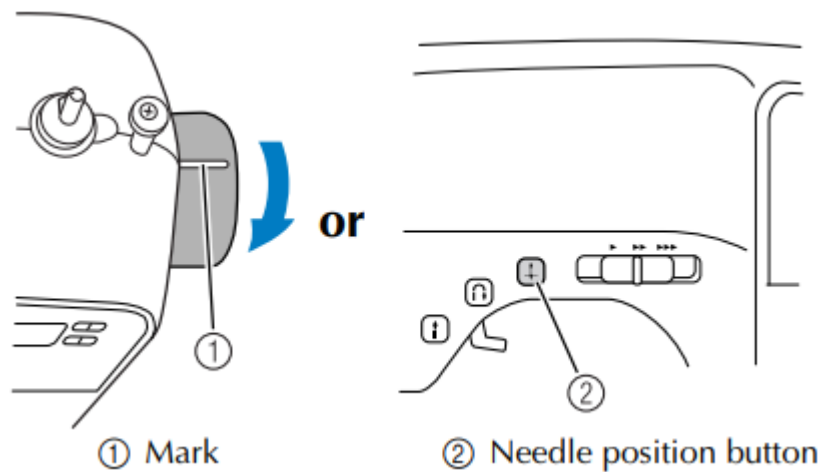

- If the needle is not correctly raised, the sewing machine can not be threaded. Be sure to turn the handwheel so that the mark on the wheel points up before threading the sewing machine.

3. Pull up the spool pin as far as possible, and then put a spool of thread on this pin.
4. Feed the upper thread as shown in the figure on the previous page.
5. Make sure you guide the thread through the thread take-up lever from right to left.

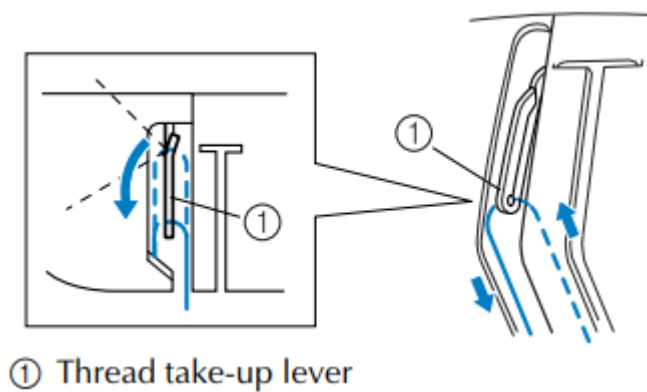

6. Put the thread behind the needle bar thread guide above the needle.

The thread can easily be passed behind the needle bar thread guide by holding the thread in your left hand, then feeding the thread with your right hand.

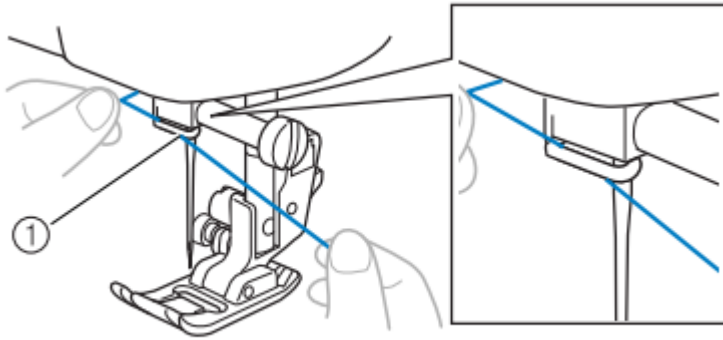

① Needle bar thread guide

7. Thread the needle from front to back and pull out about 5 cm (2 inch) of thread.

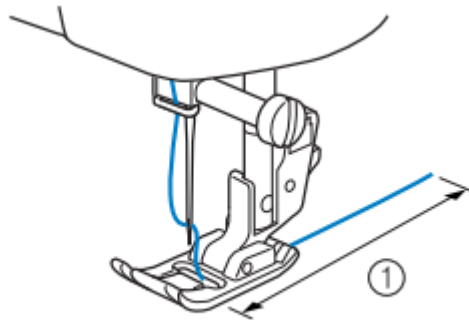

① 5 cm (2 inch)

Using the needle threader (for models equipped with the needle threader)

1. Follow steps 1 through 2 of the procedure in “Upper threading” to thread the machine to the needle bar thread guide.
2. Lower the presser foot lever.
3. While lowering the needle threader lever, hook the thread onto the guide.

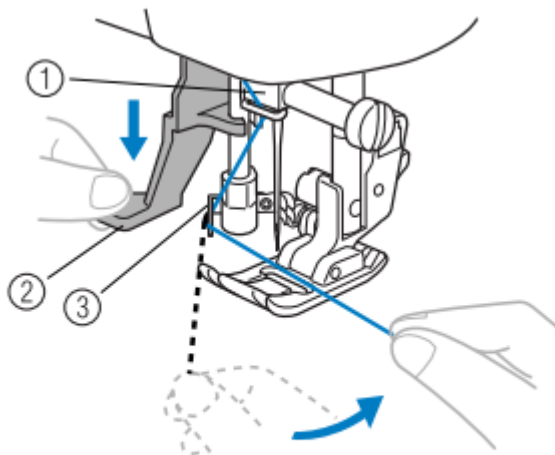

- ① Needle holder
- ② Needle threader lever
- ③ Guide



4. Fully lower the needle threader lever.

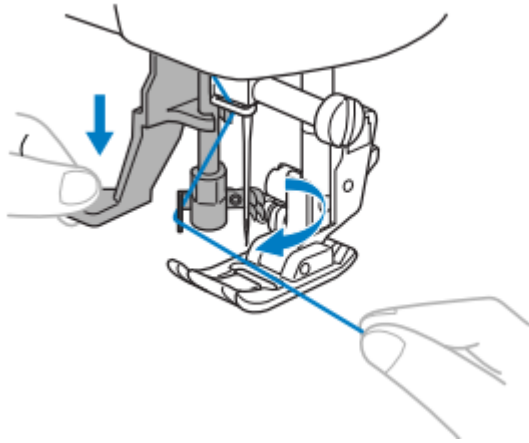

- The end of the needle threader rotates toward you and the hook passes through the eye of the needle.

5. Catch the thread on the hook as shown below.

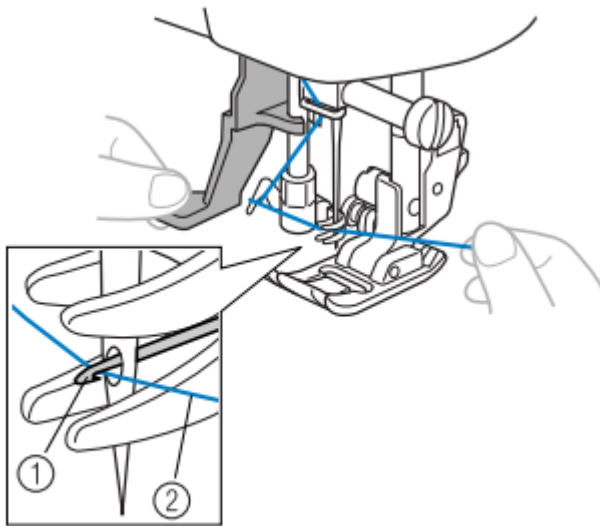

- ① Hook
- ② Thread

6. While lightly holding the thread, release the needle threader lever. The hook will pull the thread through the needle.

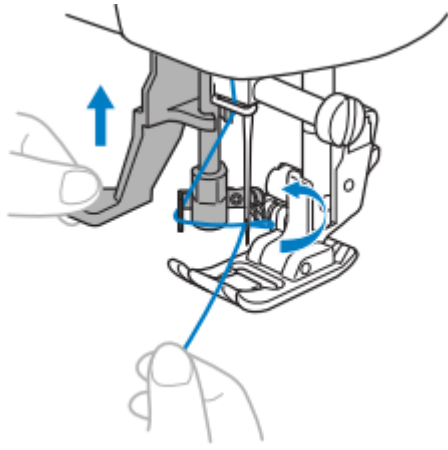

7. Pull out about 5 cm (2 inch) of thread through the needle toward the back of the sewing machine.

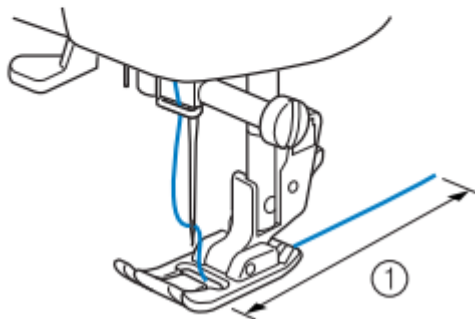
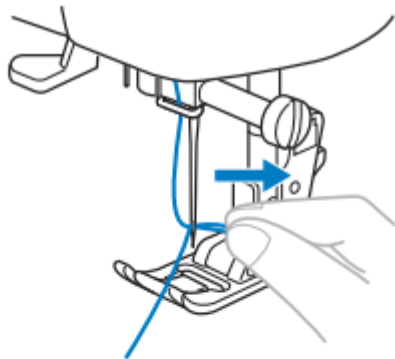

① 5 cm (2 inch)

Drawing up the lower thread

1. Lightly hold the end of the upper thread.

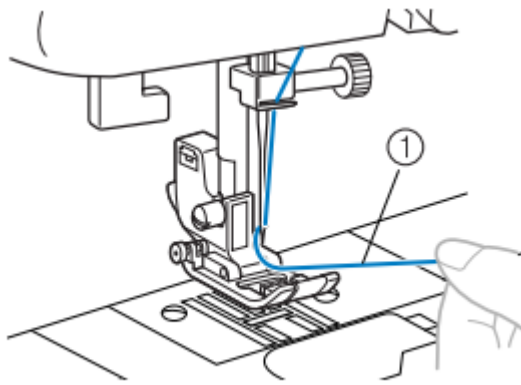

① Upper thread

2. While holding the end of the upper thread, raise the needle either by turning the handwheel toward you (counterclockwise) so that the mark on the wheel points up or by pressing  (needle position button) (for models equipped with the needle position button) once or twice.

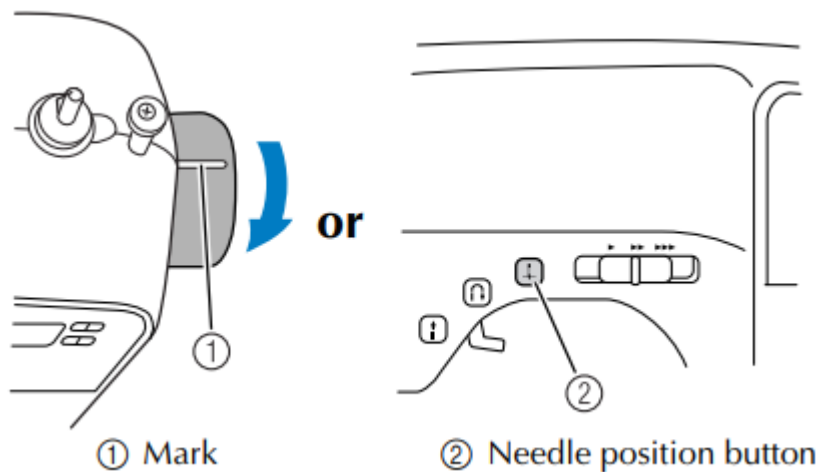

① Mark

② Needle position button

3. Pull on the upper thread to draw up the lower thread.

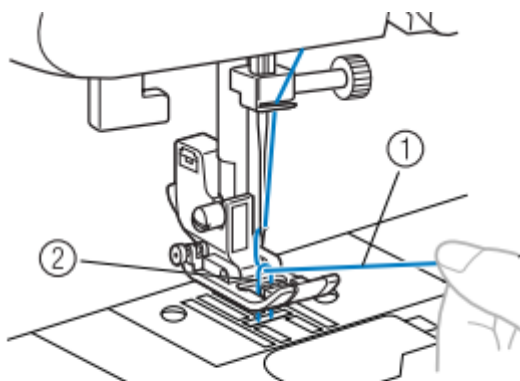

① Upper thread

② Lower thread

4. Pull out about 10 cm (4 inch) of both threads and pull them toward the back of the machine under the presser foot.

REPLACING THE NEEDLE

Checking the needle

Sewing with a bent needle is extremely dangerous since the needle may break while the machine is being operated.

Before using the needle, place the flat side of the needle on a flat surface and check that the distance between the needle and the flat surface is even.

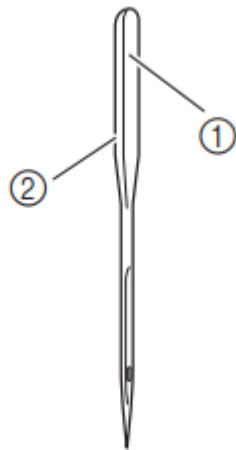

- ① Flat side
- ② Needle type marking

• Correct needle

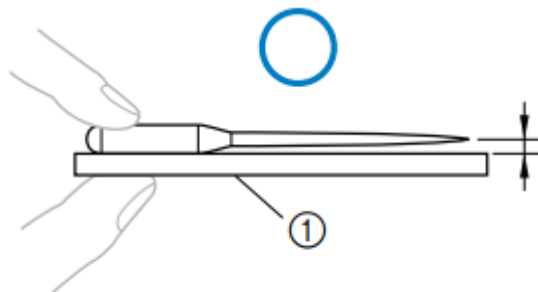

- ① Flat surface

• Incorrect needle

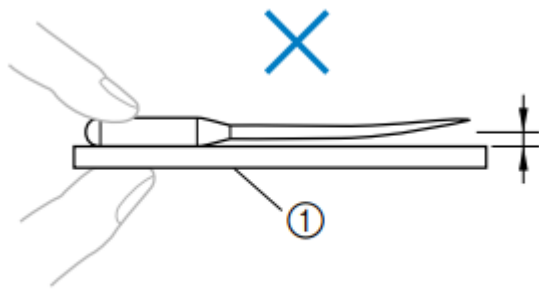

If the distance between the needle and the flat surface is not even, the needle is bent. Do not use a bent needle.



① Flat surface

Replacing the needle

Replace the needle as described below. Use the screwdriver and a needle that has been determined to be straight according to the instructions in “Checking the needle” .

1. Raise the needle by turning the handwheel toward you (counterclockwise) so that the mark on the wheel points up. (With models equipped with  (needle position button), raise the needle by pressing  once or twice.)

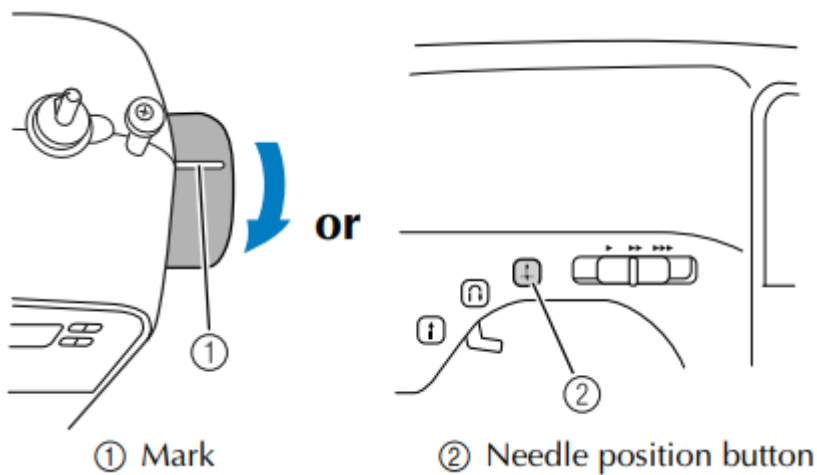

① Mark

② Needle position button

2. Turn off the sewing machine.

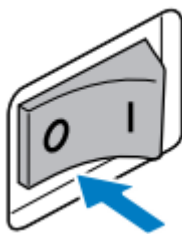

3. Lower the presser foot lever.

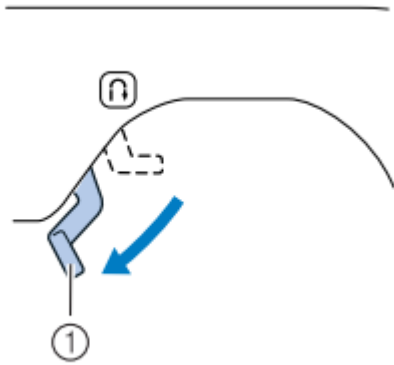

① Presser foot lever

4. Hold the needle with your left hand, and then use a screwdriver to turn the needle clamp screw counterclockwise to remove the needle.

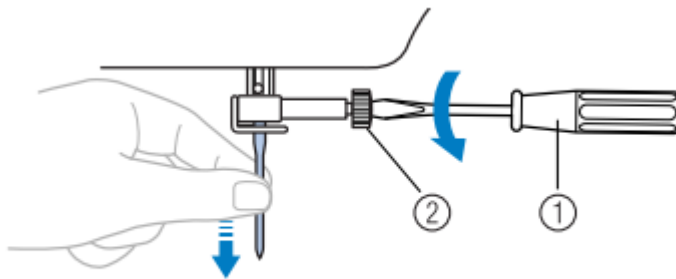

① Screwdriver
② Needle clamp screw

- Do not apply strong force when loosening or tightening the needle clamp screw, otherwise certain parts of the sewing machine may be damaged.

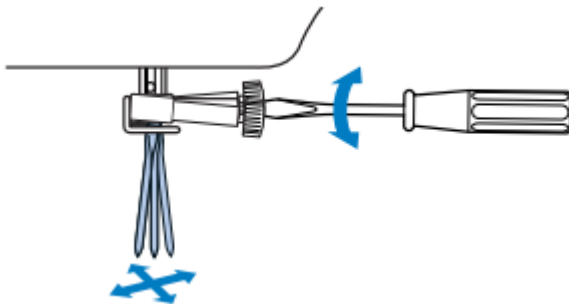

5. With the flat side of the needle toward the rear of the machine, insert the needle until it touches the needle stopper.

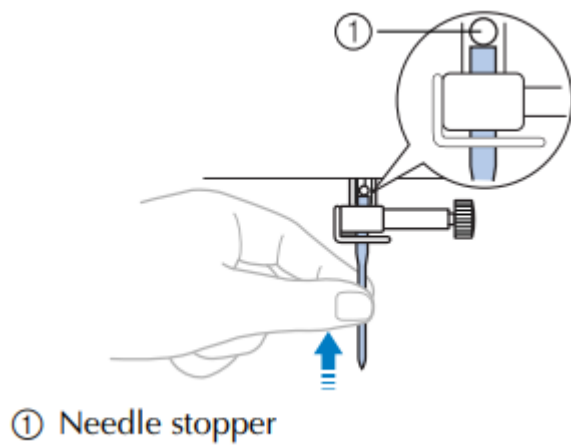

6. While holding the needle with your left hand, use the screwdriver to tighten the needle clamp screw by turning it clockwise.

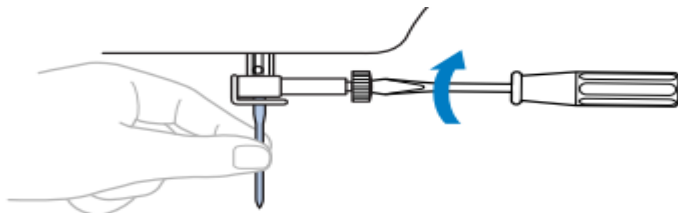

Install the twin needle in the same way.

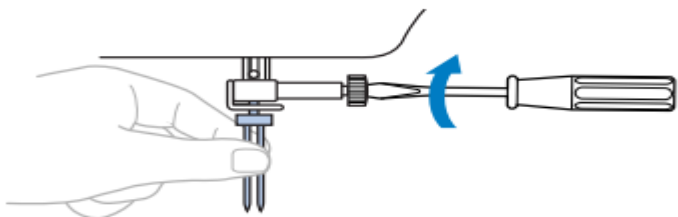

Sewing with a twin needle

We have designed your machine so you can sew with this needle and two top threads. You can use the same color or two different colors of thread for making decorative stitches.

For details on the stitches that can be sewn with the twin needle, refer to “STITCH SETTINGS”

Twin needle threading

1. Attach the twin needle.

Attach the twin needle in the same way as a . single needle

2. Attach the extra spool pin.

Put the extra spool pin in the hole on the top of the machine. Put the second spool of thread onto the extra spool pin.

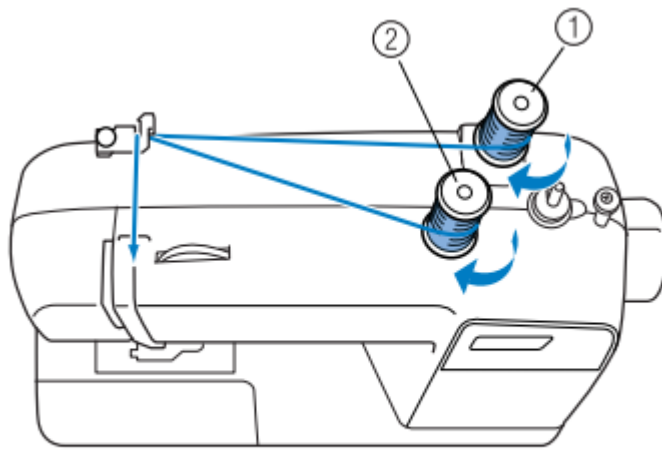

- ① First spool
- ② Second spool

3. Use the thread from the first spool to thread the machine to the needle bar thread guide.

The path for threading the machine to the needle bar thread guide is the same as for normally threading the machine (for a single needle). See page 18 for more details.

4. Thread the left needle from front to back.

5. Use the thread from the second spool to thread the machine to the thread take-up lever.

The path for threading the machine to the thread take-up lever is the same as for normally threading the machine (for a single needle).

6. Thread the right needle from front to back.

Do not pass the thread behind the needle bar thread guide

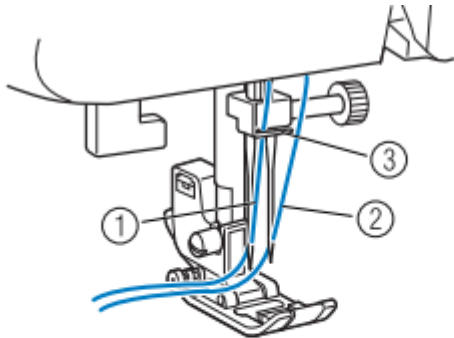



- ① Left needle thread passes through the needle bar thread guide.
- ② Right needle thread passes in front of the needle bar thread guide.
- ③ Needle bar thread guide

REPLACING THE PRESSER FOOT

Replacing the presser foot

Replace the presser foot as described below.

1. Raise the needle by turning the handwheel toward you (counterclockwise) so that the mark on the wheel points up. (With models equipped with , raise the needle by pressing  once or twice.)

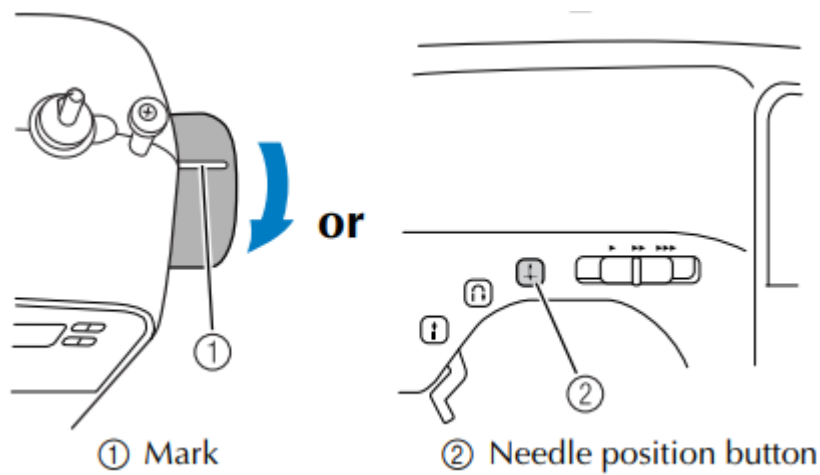

2. If the sewing machine has been turned on, turn it off.

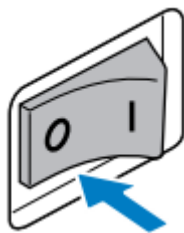

3. Raise the presser foot lever.

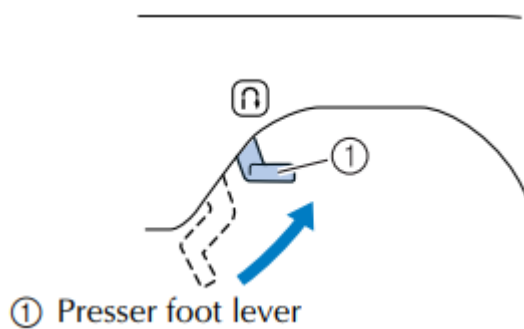

4. Press the black button at the back of the presser foot holder to release the presser foot.

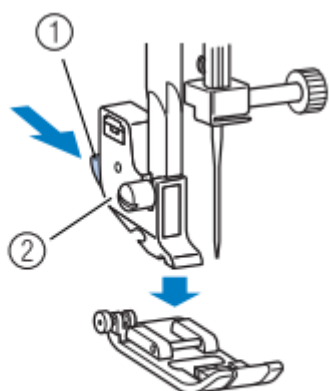

- ① Black button
- ② Presser foot holder

5. Place a different presser foot below the holder so that the presser foot pin is aligned with the shank in the holder.

Position the presser foot so the letter indicating the presser foot type (J, A, etc.) is positioned to be read.

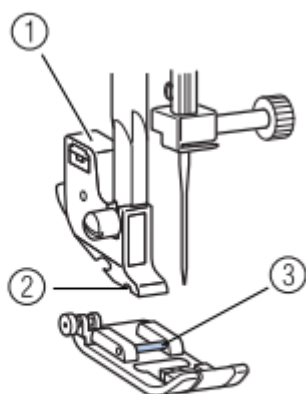

- ① Presser foot holder
- ② Shank
- ③ Pin

6. Slowly lower the presser foot lever so that the presser foot pin snaps into the shank in the presser foot holder.

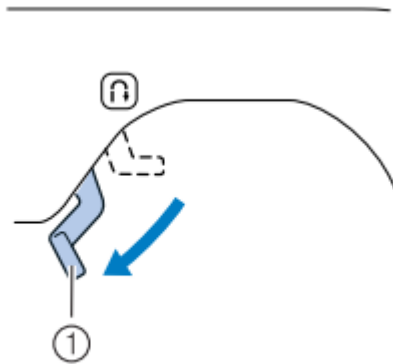

① Presser foot lever

- The presser foot is attached.

7. Raise the presser foot lever to check that the presser foot is securely attached.

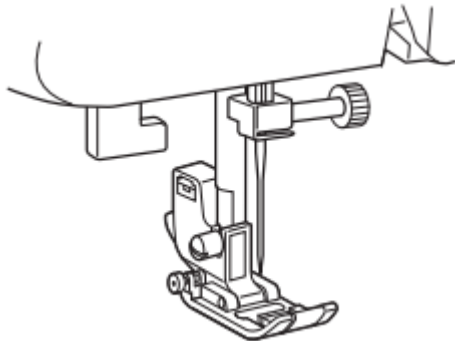

Removing the presser foot holder

Remove the presser foot holder when cleaning the sewing machine or when installing a presser foot that does not use the presser foot holder, such as the quilting foot. Use the screwdriver to remove the presser foot holder.

Removing the presser foot holder

1. Remove the presser foot.
2. Use the screwdriver to loosen the presser foot holder screw.

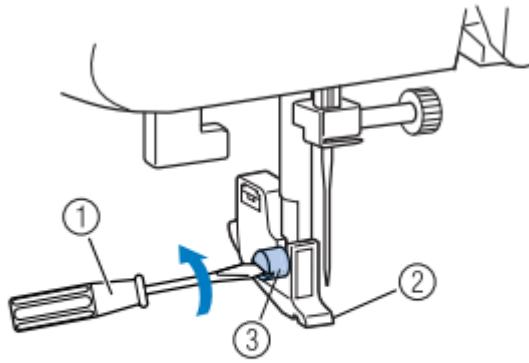

- ① Screwdriver
- ② Presser foot holder
- ③ Presser foot holder screw

Attaching the presser foot holder

1. Align the presser foot holder with the lower- left side of the presser bar.

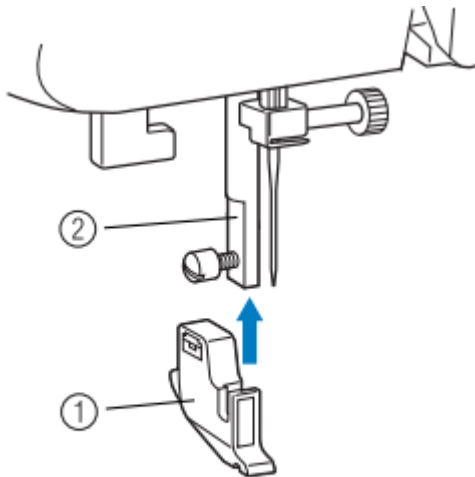

- ① Presser foot holder
- ② Presser bar

2. Hold the presser foot holder in place with your right hand, and then tighten the screw using the screwdriver in your left hand.

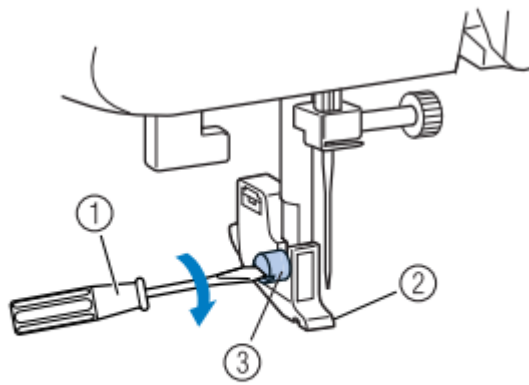

- ① Screwdriver
- ② Presser foot holder
- ③ Presser foot holder screw

SEWING BASICS

SEWING

Basic sewing operations are described below.

Before operating the sewing machine, read the following precautions.

General sewing procedure

Follow the basic procedures below to sew.

1 Turn on the machine.	Turn on the sewing machine. For details on turning on the machine, refer to “Turning on the machine” (page 9).
↓	
2 Select the stitch.	Select the stitch appropriate for the area to be sewn. For details on selecting a stitch, refer to “Selecting a stitch” (page 28).
↓	
3 Attach the presser foot.	Attach the presser foot appropriate for the stitch. For details on replacing the presser foot, refer to “Replacing the presser foot” (page 25).
↓	
4 Start sewing.	Position the fabric, and then start sewing. When sewing is finished, cut the threads. For details on starting to sew, refer to “Starting to sew” (page 29).

Selecting a stitch

Using the stitch selection keys, select the desired stitch.

When the sewing machine is turned on, the straight stitch (Fleft needle position) is selected.

[Example] Selecting stitch  (No. 04)

1. Turn on the sewing machine.

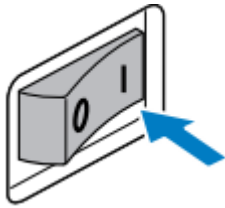

2. (For models equipped with the character stitch key)

Confirm that the utility stitch indicator is lit. If it is not lit, press the utility stitch key.

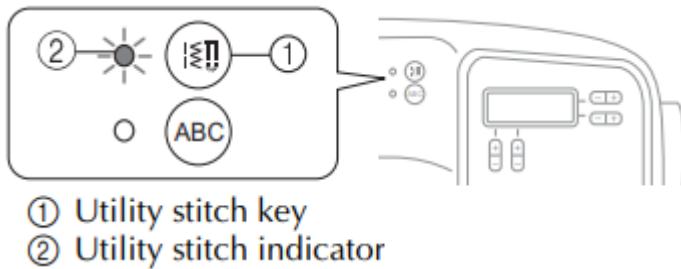

4. Press  (stitch selection keys) to select pattern No. 04.

Press the "+" or "-" side of  to increase or reduce the number.

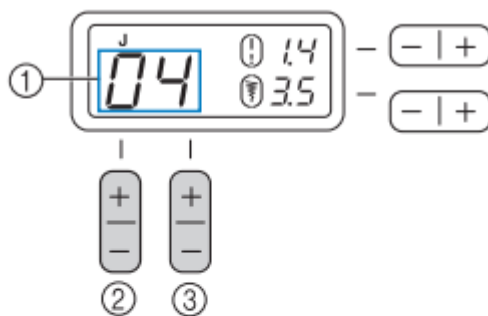

- ① Pattern No. of the selected stitch
- ② Changes the digit on the left.
- ③ Changes the digit on the right.

- The stitch is selected.

4. Attach the presser foot indicated on the LCD.



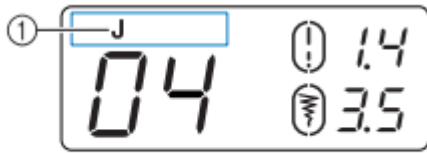

① The presser foot to use

5. If necessary, press the “+” or “-” side of  (stitch length adjustment key) to increase or reduce the stitch length.

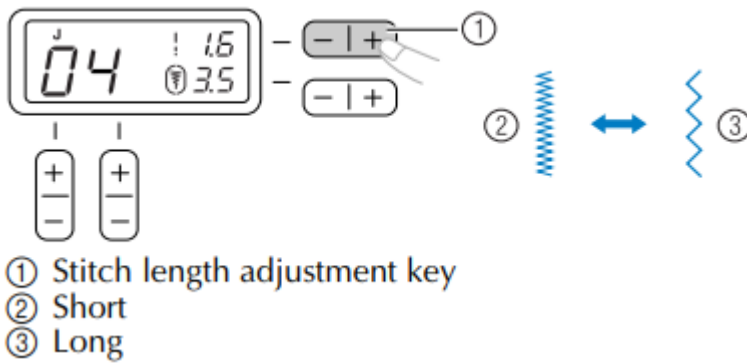

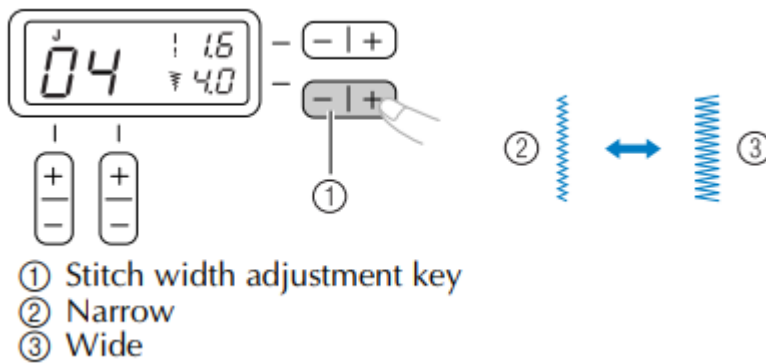

6. If necessary, press the “+” or “-” side of  (stitch width adjustment key) to increase or reduce the stitch width.



7. When you have finished making adjustments, start sewing.

Starting to sew

1. Raise the needle by turning the handwheel toward you (counterclockwise) so that the mark on the wheel points up. (With models equipped with , raise the needle by pressing  once or twice.)

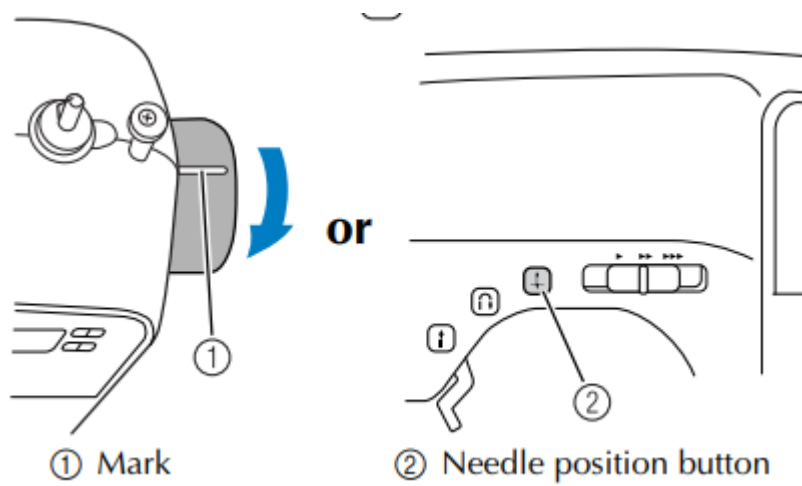

2. Raise the presser foot lever.

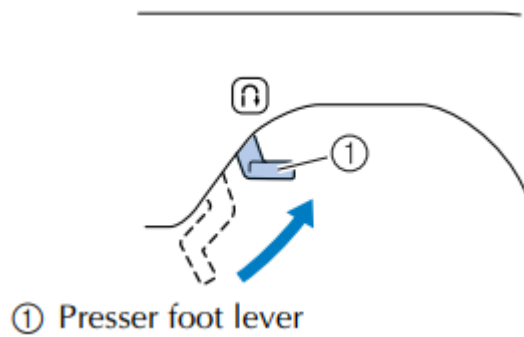

3. Place the fabric under the presser foot, pass the thread under the presser foot, and then pull out about 5 cm (2 inch) of thread toward the rear of the machine.

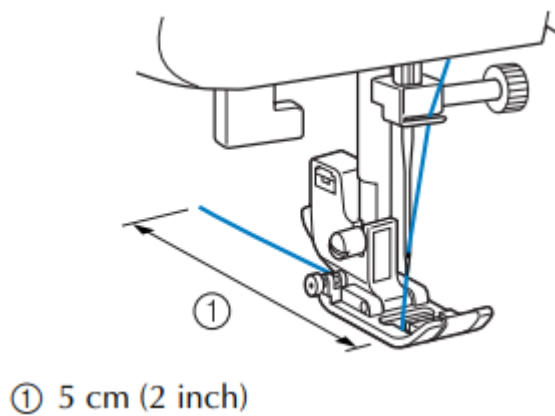

4. While holding the end of the thread and the fabric with your left hand, turn the handwheel toward you (counterclockwise) with your right hand to lower the needle to the starting point of the stitching.

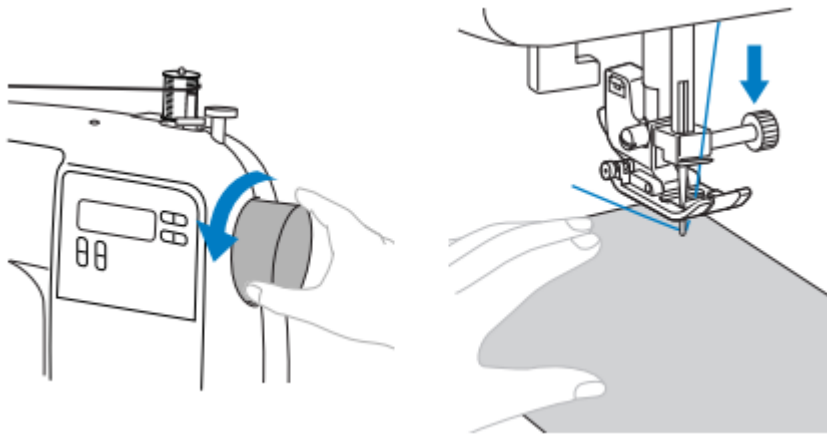

5. Lower the presser foot lever.

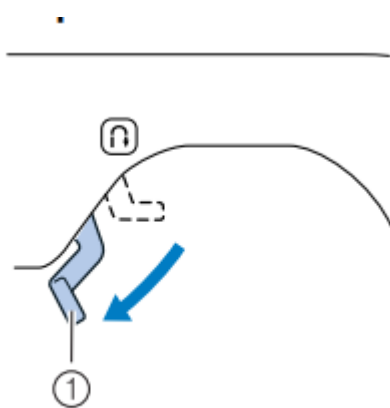

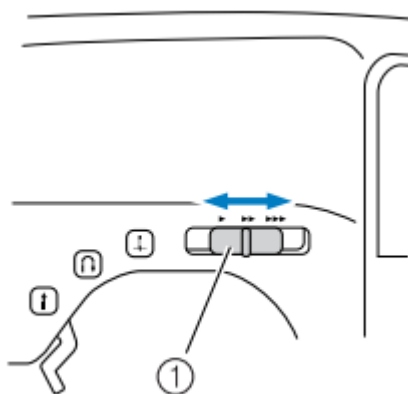

① Presser foot lever

6. On models equipped with a sewing speed controller, slide the sewing speed controller to the left or right to adjust the sewing speed. Refer to “Sewing speed controller (for models equipped with the sewing speed controller)”



① Sewing speed controller

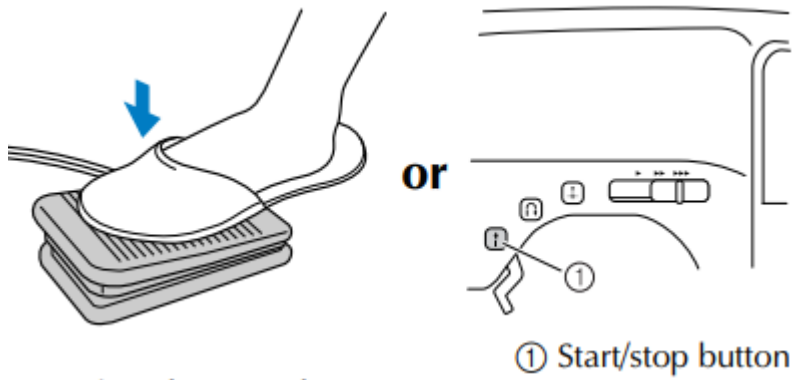

7. Slowly press down on the foot controller. (With models equipped with  (start/stop button), if the foot controller is not connected, press  once.)



- The machine starts sewing.

9. Take your foot off the foot controller, or press start/stop button) once (if the machine was started by pressing ® (start/stop button) for models equipped with the start/stop button).

The machine stops sewing.

Raise the needle by turning the handwheel toward you (counterclockwise) so that the mark on the wheel points up. (With models equipped with  (needle position button), raise the needle by pressing  once or twice.)

10. Raise the presser foot lever.

11. Pull the fabric to the left side of the machine, and then pass the threads through the thread cutter to cut them.

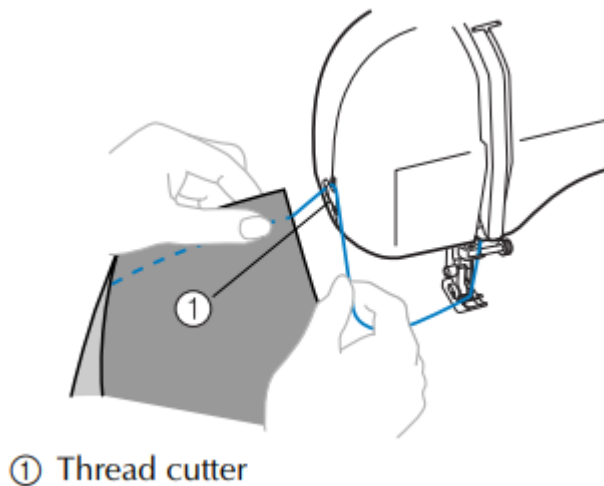

① Thread cutter

Sewing reinforcement stitches

When sewing stitches other than straight or zigzag stitches that are secured with reverse stitching, pressing  (reverse/reinforcement stitch button) sews reinforcement stitches, 3 to 5 stitches on

top of each other.

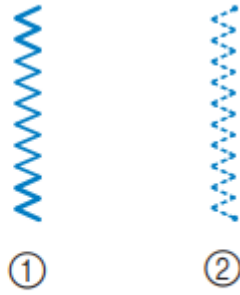

- ① Reverse stitching
- ② Reinforcement stitching

Adjusting thread tension

The thread tension will affect the quality of your stitches. You may need to adjust it when you change fabric or thread.

Correct tension

Correct tension is important as too much or too little tension will weaken your seams or cause puckers on your fabric.

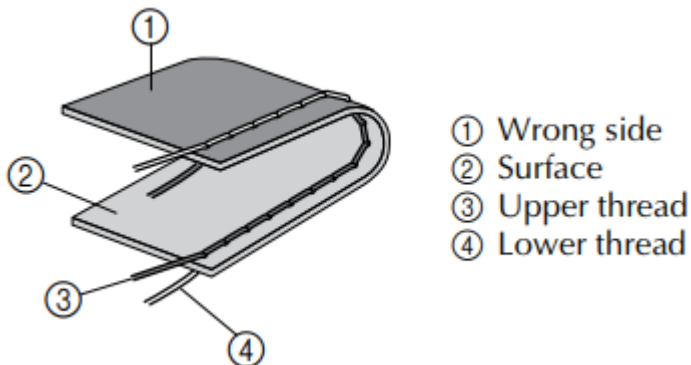

- ① Wrong side
- ② Surface
- ③ Upper thread
- ④ Lower thread

Upper tension is too tight

Loops will appear on the surface of the fabric.

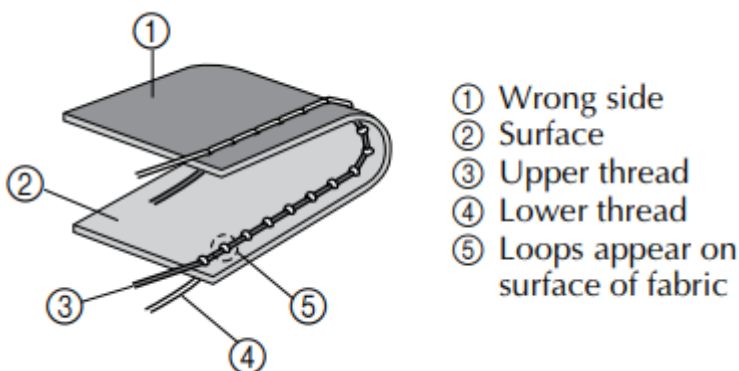

- ① Wrong side
- ② Surface
- ③ Upper thread
- ④ Lower thread
- ⑤ Loops appear on surface of fabric

Solution

Reduce the tension by turning the upper tension-control dial to a lower number.

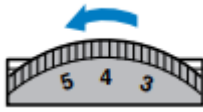

Upper tension is too loose

Loops appear on the wrong side of the fabric.

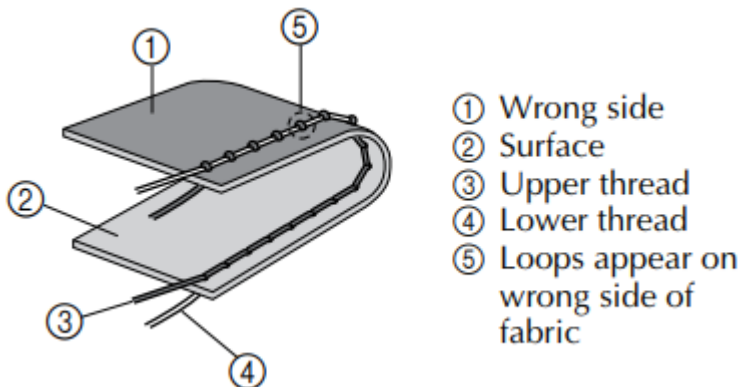

Solution

Increase the tension by turning the upper tension-control dial to a higher number.

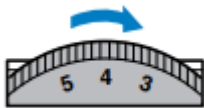

MAINTENANCE

Simple sewing machine maintenance operations are described below.

Cleaning the machine surface

If the surface of the machine is dirty, lightly soak a cloth in neutral detergent, squeeze it out firmly, and then wipe the surface of the machine. After cleaning it once with a wet cloth, wipe it again with a dry cloth.

Cleaning the bobbin case

Sewing performance will suffer if dust collects in the bobbin case; therefore, it should be cleaned periodically.

1. Switch the machine off and unplug it.
2. Raise the needle and the presser foot.

3. Loosen the presser-foot screw and the needle clamp screw to remove the presser-foot holder and the needle.

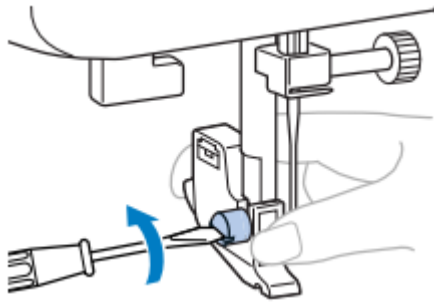

4. Grasp both sides of the needle plate cover, and then slide it toward you to remove the needle plate cover.

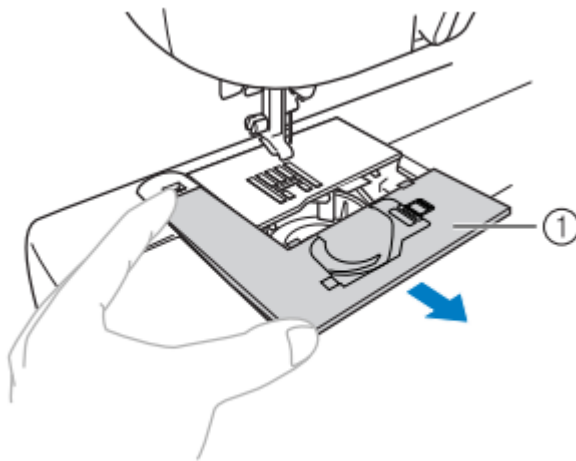

① Needle plate cover

5. Remove the bobbin case.

Grasp the bobbin case, and then pull it out.

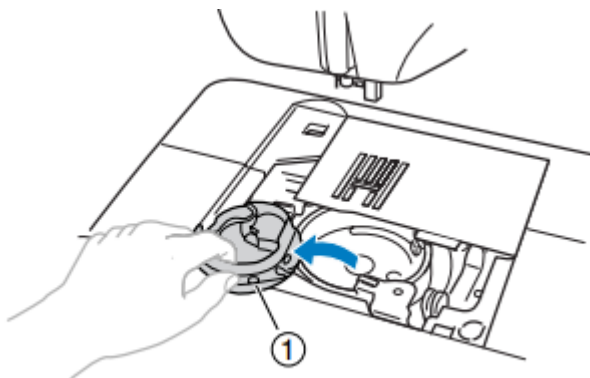

① Bobbin case

6. Use the cleaning brush or a vacuum cleaner to remove any dust from the race and its surrounding area.

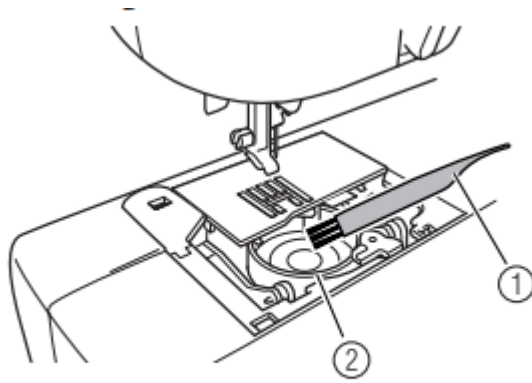

- ① Cleaning brush
- ② Race

- Do not put oil on the bobbin case.

7. Insert the bobbin case so that the ▲ mark on the bobbin case aligns with the ● mark on the race.

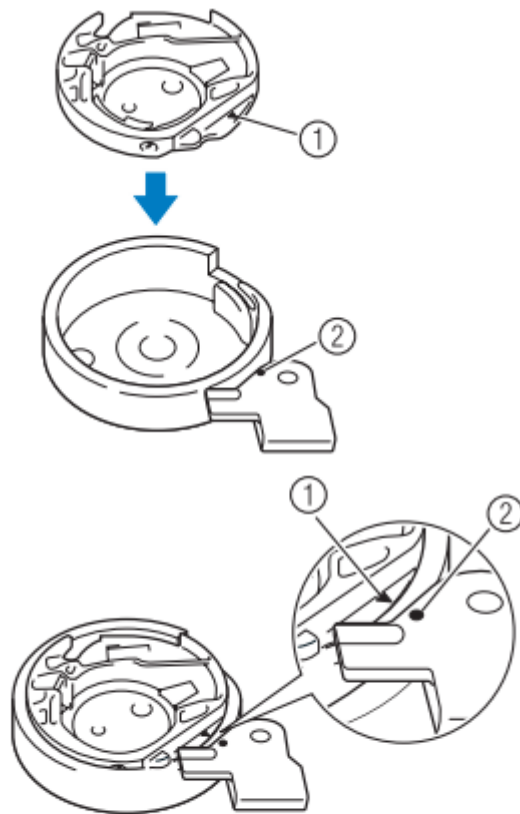

- Align the ▲ and ● marks.

- ① ▲ mark
- ② ● mark

- Make sure that the indicated points are aligned before installing the bobbin case.

8. Put the tabs on the needle plate cover into the needle plate, and then slide the cover back on.

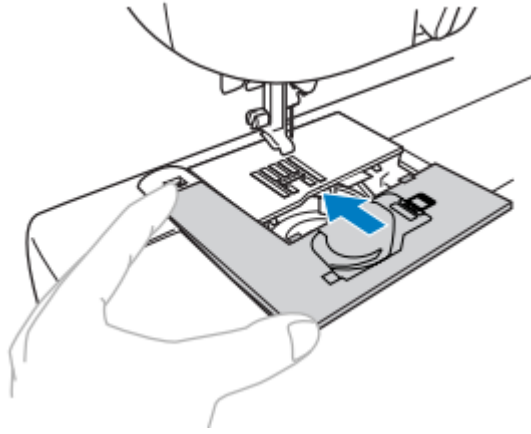

TROUBLESHOOTING

If the machine stops operating correctly, check the following possible problems before requesting service.

You can solve most problems by yourself. If you need additional help, the Brother Solutions Center offers the latest FAQs and troubleshooting tips. Visit us at [<http://solutions.brother.com>].

If the problem persists, contact your dealer or the nearest authorized service center.

Symptom	Possible cause	How to
The sewing machine does not work.	The machine is not plugged in.	Plug the machine in.
	The main power switch is turned off.	Turn on the main power switch.
	The bobbin winder shaft is pushed to the right.	Move the bobbin winder shaft to the left.
	You have not used the foot controller properly.	Use the foot controller properly.
The needle breaks.	The needle is not fitted properly.	Fit the needle properly.
	The needle clamp screw is loose.	Use the screwdriver to tighten the screw.
	The needle is bent or blunt.	Replace the needle.
	You have not used the right combination of fabric, thread and needle.	Choose a thread and needle suitable for the type of fabric.
	The presser foot you are using is not appropriate for the type of stitch that you want to sew.	Attach the presser foot that is appropriate for the type of stitch that you want to sew.
	The upper thread tension is too tight.	Loosen the upper thread tension.
	You are pulling the fabric too much.	Lightly guide the fabric.
	The area around the hole in the needle plate is scratched.	Replace the needle plate. Contact your retailer or the service center.
The area around the hole in the presser foot is scratched.	Replace the presser foot. Contact your retailer or the service center.	



	The bobbin case is scratched.	Replace the bobbin case. Contact your retailer or the service center.
	You have not used a bobbin that has been designed for this machine.	Incorrect bobbins will not work. Use the bobbin that has been designed for this machine.
The upper thread breaks.	You have not threaded the upper thread properly, (for example, you have not fitted the spool properly, or the thread has come out of the guide above the needle.)	Correct the upper thread.
	There are knots or tangles in the thread.	Remove any knots or tangles.
	The needle is not appropriate for the thread you are using.	Choose a needle that is appropriate for the thread and the stitch.
	The upper thread tension is too tight.	Loosen the upper thread tension.
	The thread is tangled, for example, in the bobbin case.	Remove the tangled thread from the bobbin case, clean the bobbin case, and rethread the thread.
	The needle is bent or blunt.	Replace the needle.



	You have not inserted the needle properly.	Insert the needle properly.
	The area around the hole in the needle plate is scratched.	Replace the needle plate. Contact your retailer or the nearest authorized service center.
	The area around the hole in the presser foot is scratched.	Replace the presser foot. Contact your retailer or the nearest authorized service center.
	The bobbin case is scratched, or has a burr on it.	Replace the bobbin case. Contact your retailer or the nearest authorized service center.
	You have not used a bobbin that has been designed for this machine.	Incorrect bobbins will not work properly. Only use a bobbin that has been designed for this machine.
The lower thread is tangled or breaks.	You have not wound the bobbin thread properly.	Wind the bobbin thread properly.
	The bobbin is scratched or does not turn smoothly.	Replace the bobbin.
	The thread is tangled.	Remove the tangled thread and clean the bobbin case.
	You have not used a bobbin that has been designed for this machine.	Incorrect bobbins will not work properly. Only use a bobbin that has been designed for this machine.
	Bobbin is set incorrectly.	Reset the bobbin thread correctly.
The thread is tangled on the	The upper thread was not threaded correctly.	Correct the upper threading.

wrong side of the fabric.		
The thread tension is incorrect.	You have not threaded the upper thread properly.	Correct the upper threading.
	You have not wound the bobbin thread properly.	Wind the bobbin thread properly.
	You have not threaded the right combination of thread and needle for the fabric you are using.	Choose a thread and needle that are appropriate for the type of fabric.
	You have not attached the presse* foot holder properly.	Attach the presser foot holder properly.
	The thread tension is incorrect.	Adjust the tension of the upper thread.
	You have not used a bobbin that has been designed for this machine.	Incorrect bobbins will not work properly. Only use a bobbin that has been designed for this machine.
	Bobbin is set incorrectly.	Reset the bobbin thread correctly.
The upper thread is too tight.	The bobbin thread is incorrectly installed.	Correctly install the bobbin thread.
The fabric is wrinkled.	You have not threaded the upper thread properly or wound the bobbin properly.	Thread the upper thread and wind the bobbin thread properly.
	You have not wound the spool properly.	Fit the spool properly.
	You have not used the right combination of fabric, thread and needle.	Choose a thread and needle that are appropriate for the type of fabric.

The needle is bent or blunt.

Replace the needle.



	If you are sewing thin fabric, the stitch is too thick.	Sew with stabilizer material.
	The thread tension is incorrect.	Adjust the tension of the upper thread.
Stitches are skipped.	You have not threaded the upper thread properly.	Correct the upper threading.
	You have not used the right combination of fabric, thread and needle.	Choose a thread and needle appropriate for the type of fabric.
	The needle is bent or blunt.	Replace the needle.
	You have not inserted the needle properly.	Insert the needle properly.
	Dust has accumulated under the needle plate or in the bobbin case.	Remove the needle plate cover and the bobbin case.
There is a high-pitched noise while sewing.	Dust has built up in the feed dogs or in the bobbin case.	Clean the bobbin case.
	You have not threaded the upper thread properly.	Correct the upper threading.
	The bobbin case is scratched.	Replace the bobbin case. Contact your retailer or the nearest service center.
	You have not used a bobbin that has been designed for this machine.	Incorrect bobbins will not work. Use a bobbin that has been designed for this machine.
The needle threader can not be used.	You have not moved the needle holder to its highest position.	Raise the needle either by turning the handwheel toward you (counterclockwise) or by pulling the lever so that the mark on the wheel points to the top.

		pressing  (needle position) twice.
	You have not inserted the needle properly.	Insert the needle properly.
The stitch is not sewn correctly.	The presser foot that you are using is not correct for the type of stitch.	Attach the presser foot that is appropriate for the type of stitch that you want to sew.
	The thread tension is incorrect.	Adjust the tension of the upper thread.
	The thread is tangled, for example, in the bobbin case.	Remove the tangled thread. If the thread is tangled in the bobbin case, clean the bobbin case.
	The stitch adjustment level is incorrect.	Adjust the stitch.
The fabric does not feed.	The feed dogs are lowered.	Slide the feed dog position lever to the up position.
	The stitch is too fine.	Lengthen the stitch length.
	You have not used the right combination of fabric, thread and needle.	Choose a thread and needle that are appropriate for the type of fabric you are sewing.
	The thread is tangled, for example, in the bobbin case.	Remove the tangled thread. If the thread is tangled in the bobbin case, clean the bobbin case.
The sewing light bulb does not come on.	The sewing lamp is damaged.	Contact your retailer or the nearest service center.

ERROR MESSAGES

If an operation is performed incorrectly before the sewing machine is set up, an error message appears on the operation panel. Follow the instructions indicated in the table.

If you press the stitch selection key or do the operation correctly while the error message is displayed, the message disappears.

Error Message	Probable Cause	
<i>Ei</i>	The foot controller was pressed (or the start/stop button was pressed if the foot controller is not connected) and the reverse/reinforcement stitch button was pressed while the presser foot is raised.	Lower the foot controller and continue operation.
<i>EE</i>	A stitch other than the buttonhole or bar tack stitch was selected and the foot controller was pressed (or the start/stop button was pressed if the foot controller is not connected) while the buttonhole lever is lowered.	Raise the buttonhole lever and continue operation.
<i>EE</i>	The buttonhole or bar tack stitch was selected and the foot controller was pressed (or the start/stop button was pressed if the foot controller is not connected) while the buttonhole lever is raised.	Lower the buttonhole lever and continue operation.
<i>EH</i>	The reverse/reinforcement stitch button or needle position button was pressed while the bobbin winder shaft is moved to the right.	Move the bobbin winder shaft to the left and continue operation.
<i>EE</i>	The start/stop button was pressed while the foot controller was connected.	Disconnect the foot controller, then press the start/stop button. Otherwise, press the start/stop button using the foot controller.
<i>EE</i>	The motor locked up because the thread is tangled.	Remove the thread and continue operation.

Operation beep (for models equipped with the operation beep)

Each time a key is pressed you will hear one beep. If a non-functioning key is pressed or an incorrect operation is performed you will hear two or four beeps (only for models equipped with the operation beep).

- **If a key is pressed (correct operation)**

One beep sounds.

- **If an incorrect operation is performed or a non-functioning key is pressed**

Two or four beeps sound.

- **If the machine locks up, for example, because the thread is tangled**

The sewing machine beeps for four seconds and the machine automatically stops. Be sure to check for the cause of the error, and correct it before continuing to sew.

Warning

This content is compiled from multiple sources and is provided for reference purposes only. It may not be complete or fully applicable to all situations. If you are unable to resolve your issue, please contact the product manufacturer or an authorized service provider for official support.