

Setting the Temperature Control

Cool Down Period

- For safe food storage, allow four (4) hours for freezer to cool down completely. The freezer will run continuously for the first several hours. Foods that are already frozen may be placed in the freezer after the first few hours of operation. Unfrozen foods should NOT be loaded into the freezer until freezer has operated for four (4) hours.
- When loading freezer, freeze only three (3) pounds of fresh food per cubic foot of freezer space at one time. Distribute packages to be frozen evenly throughout the freezer. It is not necessary to turn the control knob to a colder setting while freezing food.

Electromechanical Temperature Control (Chest and Some Upright Models)

The electromechanical temperature control is located inside the freezer on upright models, and on the left exterior wall on chest models (see figure 1). The temperature is factory preset to provide satisfactory food storage temperatures. However, the temperature control is adjustable to provide a range of temperatures for your personal satisfaction. To adjust the temperature setting, turn the temperature control knob clockwise or counter clockwise. Allow several hours for the temperature to stabilize between adjustments.

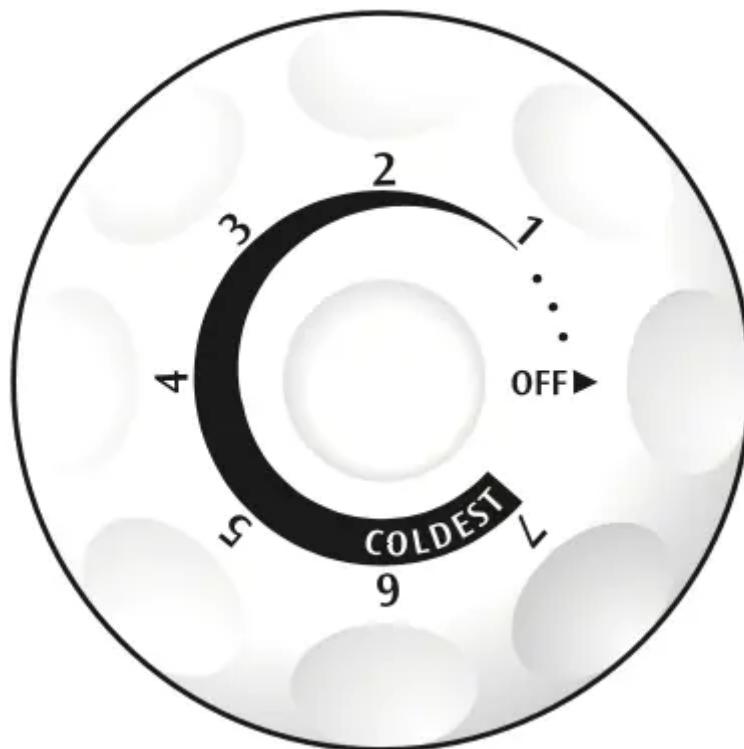

Electromechanical Control

Figure 1

Standard Electronic Temperature Control (Some Upright Frost Free Models)

The standard electronic temperature control is located inside the freezer on upright models (see Figure 2). Temperature is factory preset to provide satisfactory food storage temperatures. To adjust the temperature setting, move the UP (▲) button for warmer temperature and DOWN (▼) button for colder temperature on the control panel. Allow several hours for the temperature to stabilize between adjustments.

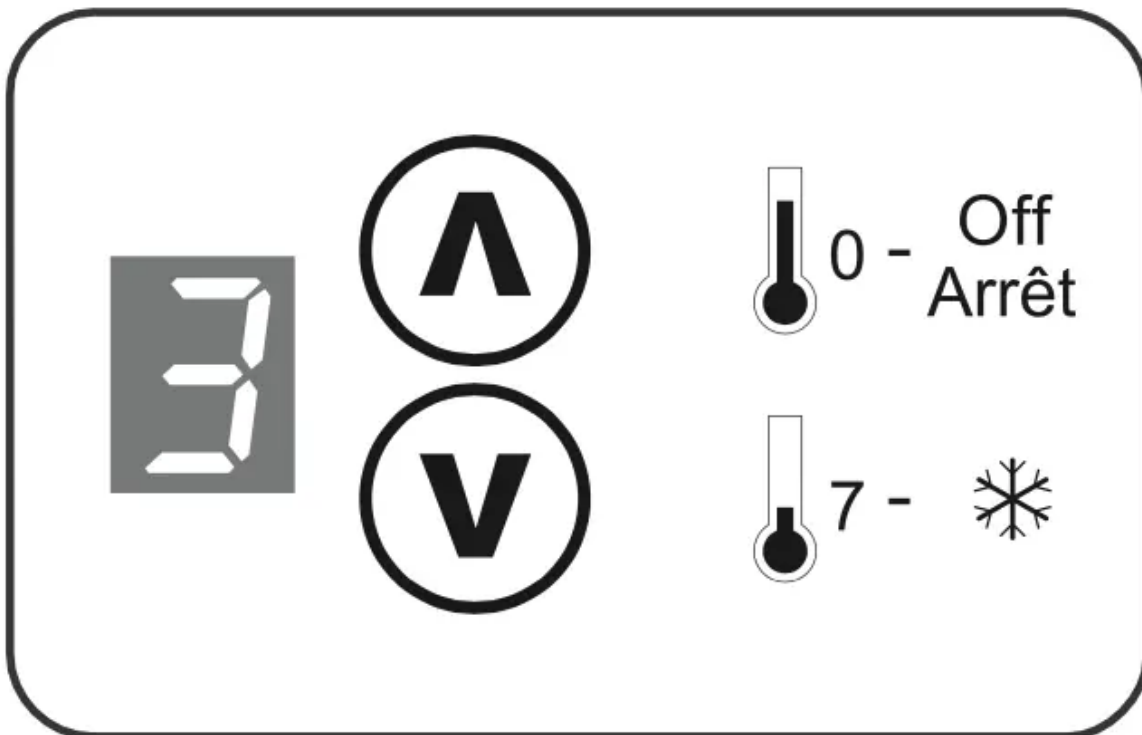

Standard Electronic Temperature Control

Figure 2

Deluxe Electronic Temperature Control (Some Upright Frost Free Models)

Refer to the Electronics Control Guide supplied when you purchase a deluxe electronic upright model. See Figure 3 for deluxe electronics control panel.



Deluxe Electronic Temperature Control

Figure 3

Freezer Optional Features

Your freezer may have some or all of the features listed below. Become familiar with these features and their use and care.

Power On Light

The power on light indicates that the freezer is properly connected to an electrical power. The light glows even when the temperature control is turned to "OFF". If the light goes out, refer to "Freezer does not run" in the Avoid Service Checklist section.

Electromechanical Temperature Alarm (Audible Only or Audible with Warning Light)

This feature is designed to provide a warning of a possible malfunction. If the temperature of the food rises to a level unsafe for long-term storage, the buzzer will sound. The red light, if equipped, will also glow. The Temp Alarm feature operates on household electricity. If power fails, the alarm will not function. An ON/OFF switch allows you to deactivate the Temp Alarm when not wanted. The freezer is shipped with the Temp Alarm in the "OFF" position (if equipped). After the freezer has run approximately four (4) hours, the red light, if equipped, will go off. Then you may activate the Temp Alarm without the alarm sounding.

Press the "ON" switch to activate the Temp Alarm feature. To deactivate, press the "OFF" switch.

If the alarm sounds, be sure freezer is properly leveled, and the door/lid closes freely and seals properly. If you suspect a technical malfunction, call an authorized service personnel immediately.

Electronic Temperature Alarm (Some Electronic Chest Models)

This feature is designed to provide a warning if the inside temperature reaches an unsafe level. The Temp Alarm feature operates on household electricity. It will not function if household electricity is interrupted.

When the freezer is initially plugged in, the red Temp Alarm indicator light blinks. The indicator light will continue to blink until the freezer has reached a safe freezing temperature. If a malfunction causes an unsafe temperature inside the freezer, the red light will blink and the buzzer will sound. To silence the buzzer, press the ALARM OFF button. The indicator light will continue to blink until a safe freezing temperature is again reached. If the problem is not solved within twelve (12) hours, the buzzer will turn on again. If the ALARM OFF button is not pressed, the buzzer will turn itself off automatically after 48 hours, but the red Temp Alarm light will continue to blink.

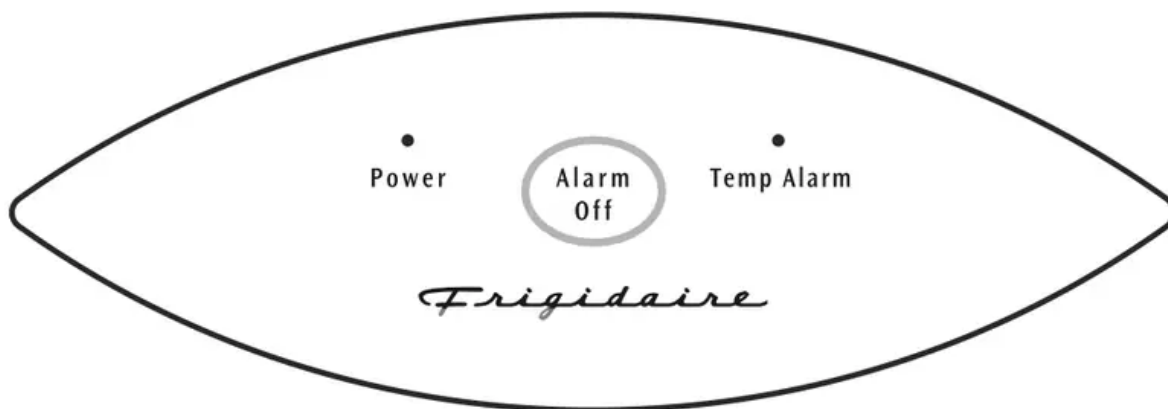

Electronic Temperature Alarm (Some Electronic Upright Models)

Refer to the Electronics Control Guide supplied when you purchase a deluxe electronic upright model.

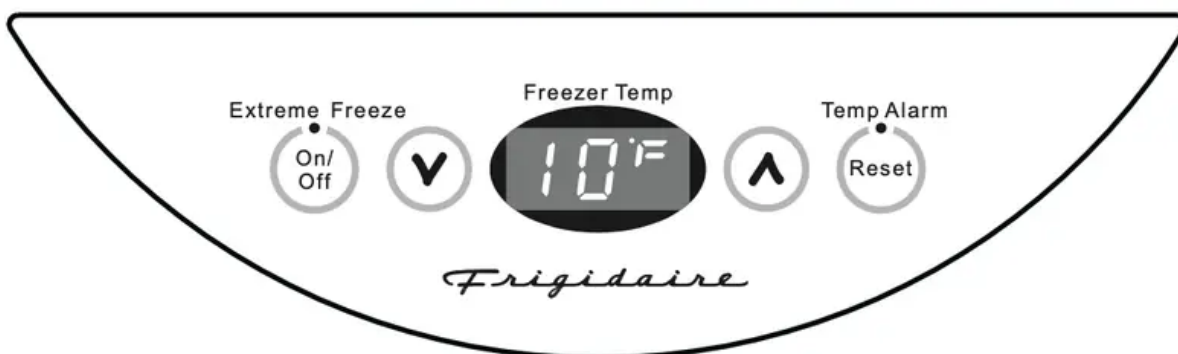

Slide-Out Basket (Some Upright Models)

The slide-out basket, located at the bottom of the freezer provides separate storage space for items that are difficult to store on freezer shelves. To remove the basket, pull out and lift up.

Security Lock with Pop-out Key

This security lock fastens the door/lid snugly, ensuring that stored food is secure. To lock or unlock the freezer, push the key into the lock and turn. The key pops out of the lock after it has been turned.

Interior Light

The light comes on automatically when the door/lid is opened. To replace the light bulb, turn the temperature control to "OFF" and unplug the electrical cord. Replace the old bulb with a bulb of the same type and wattage.

Adjustable Shelf (Some Upright Models)

This shelf can be moved to one of two positions. Lift the shelf up and out to move to the desired position.

Slide-Aside Basket (Chest Models)

This basket helps organize odd-shaped items. To reach other packages in the freezer, slide the basket aside or lift out.

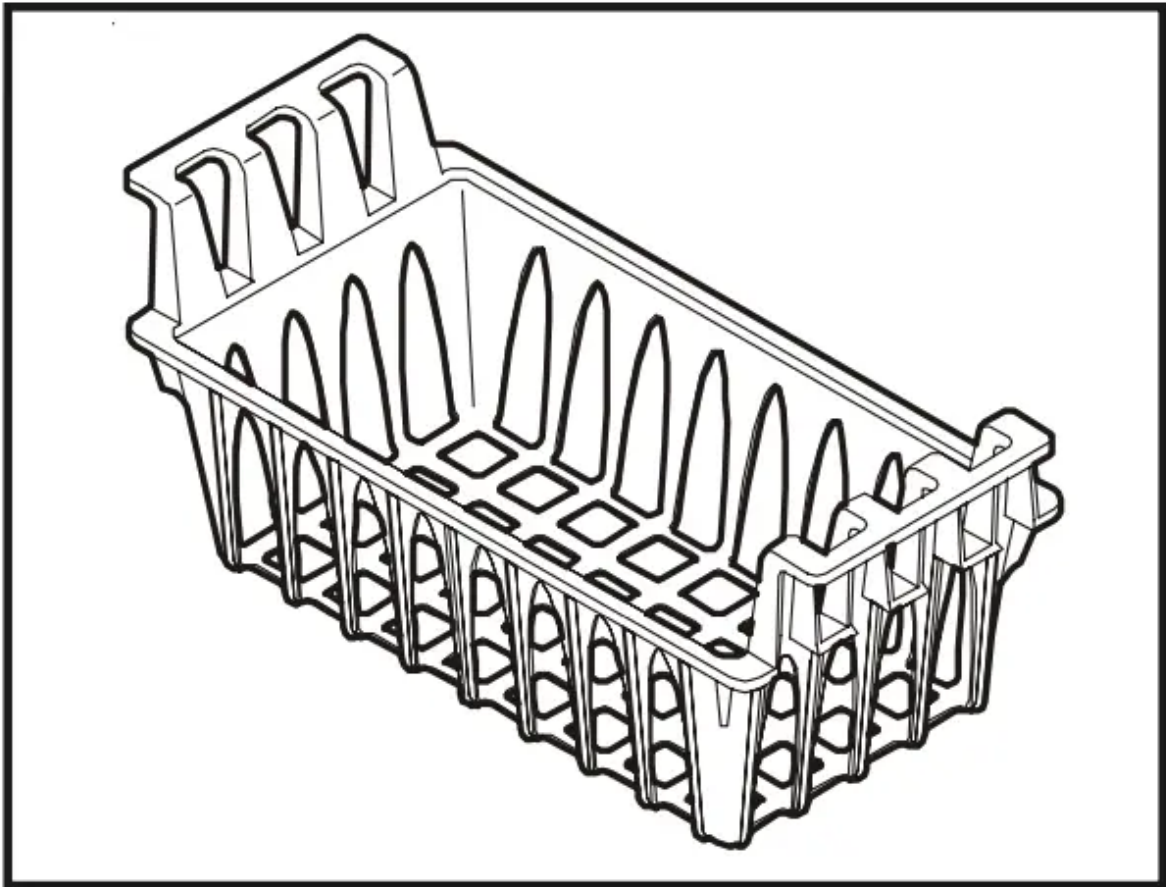

Slide-Aside Basket

Fast Freezing Shelves (Manual Defrost Upright Models)

These shelves contain cooling coils to freeze foods quickly and allow cold air to constantly circulate throughout the freezer. Do not use sharp metal objects such as ice picks or scrapers to clean the shelves. This could damage the shelves and reduce their cooling ability. These shelves are not adjustable.

Tilt-Out Shelf (Some Upright Models)

This shelf is located inside on the freezer door and provides additional storage space. To access an item, tilt the top of the “basket” shelf down.

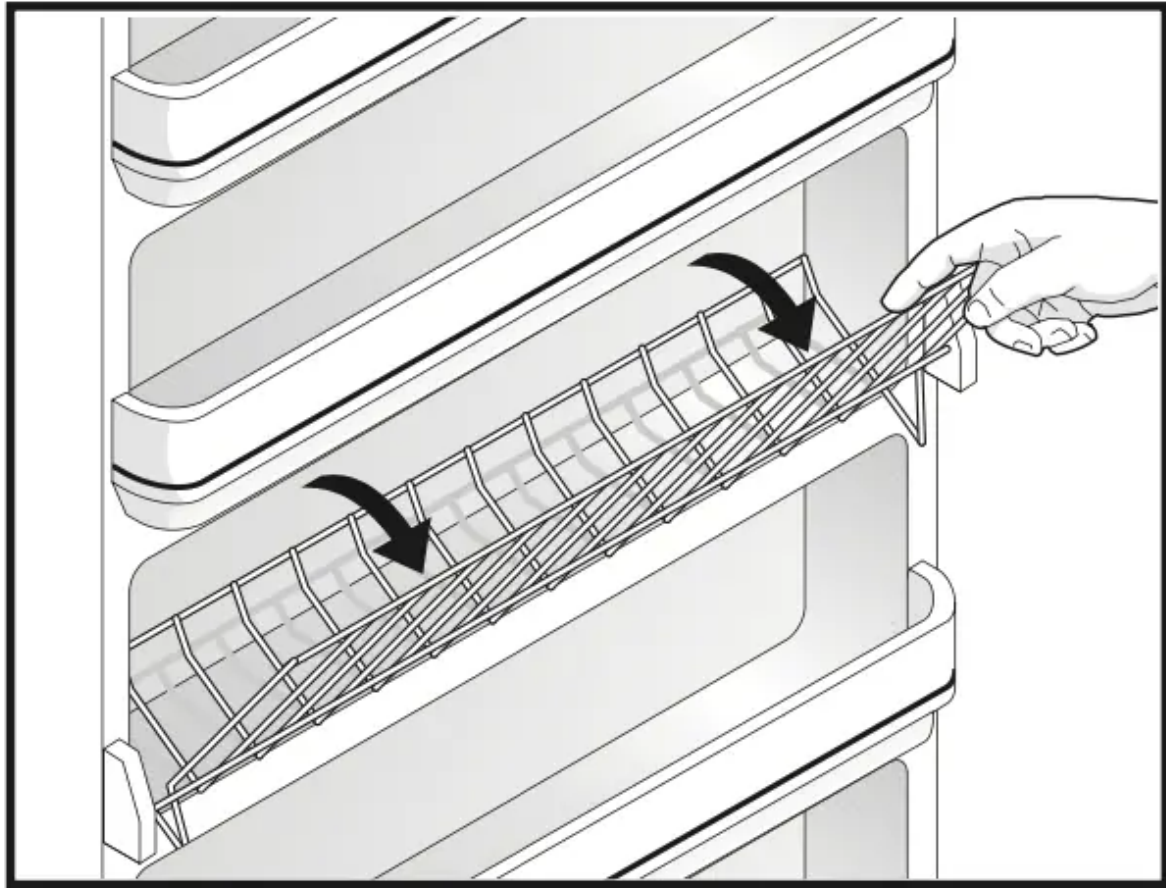

Tilt-Out Shelf

Drop Front (Some Upright Models)

The drop front, located at the bottom of the freezer, provides a separate compartment for small irregular shaped items. Lift the front up and out to remove.

Basket Divider (Some Upright Models)

Use these handy dividers to keep the various items stored in your baskets more organized. To change the location of the divider simply slide your basket out, lift up on each end of the divider until it is disengaged from the basket, place divider in the desired location (make sure it is between two vertical wires) and press down firmly on each end until it snaps into place.



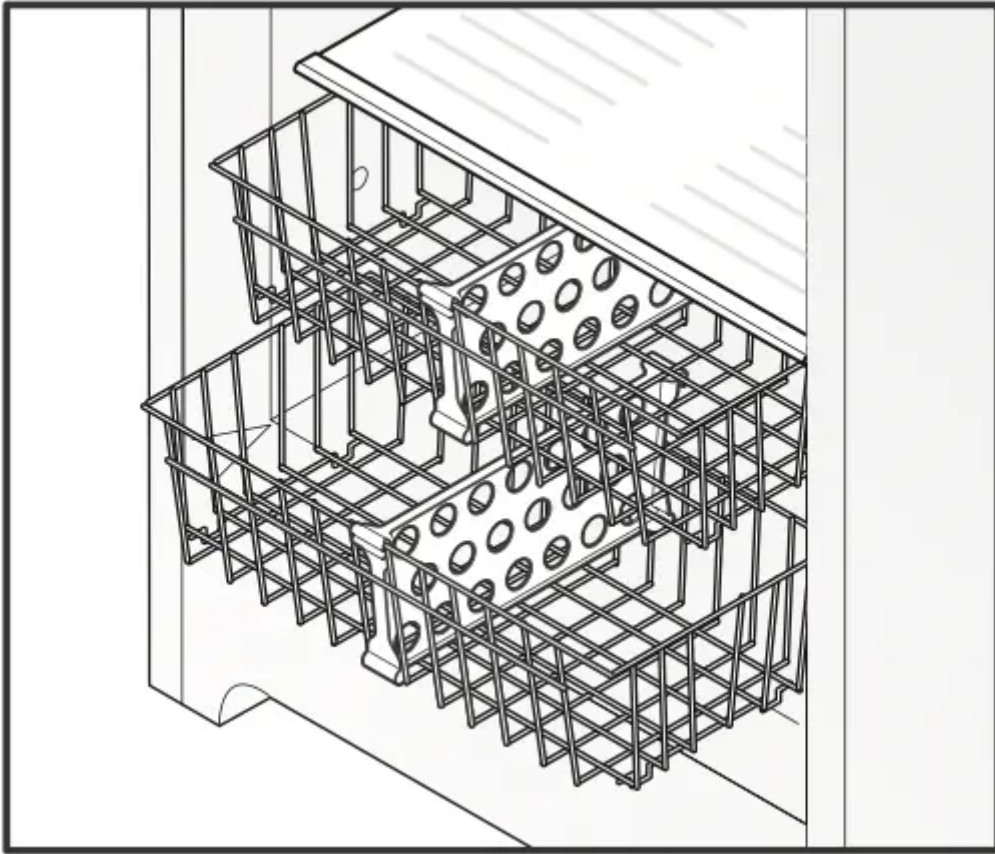

Small Item Shelf (Some Upright Models)

Use this shelf to store several of your single-serving microwavable dinners or other small items that you want to keep in an easy-to-reach spot.



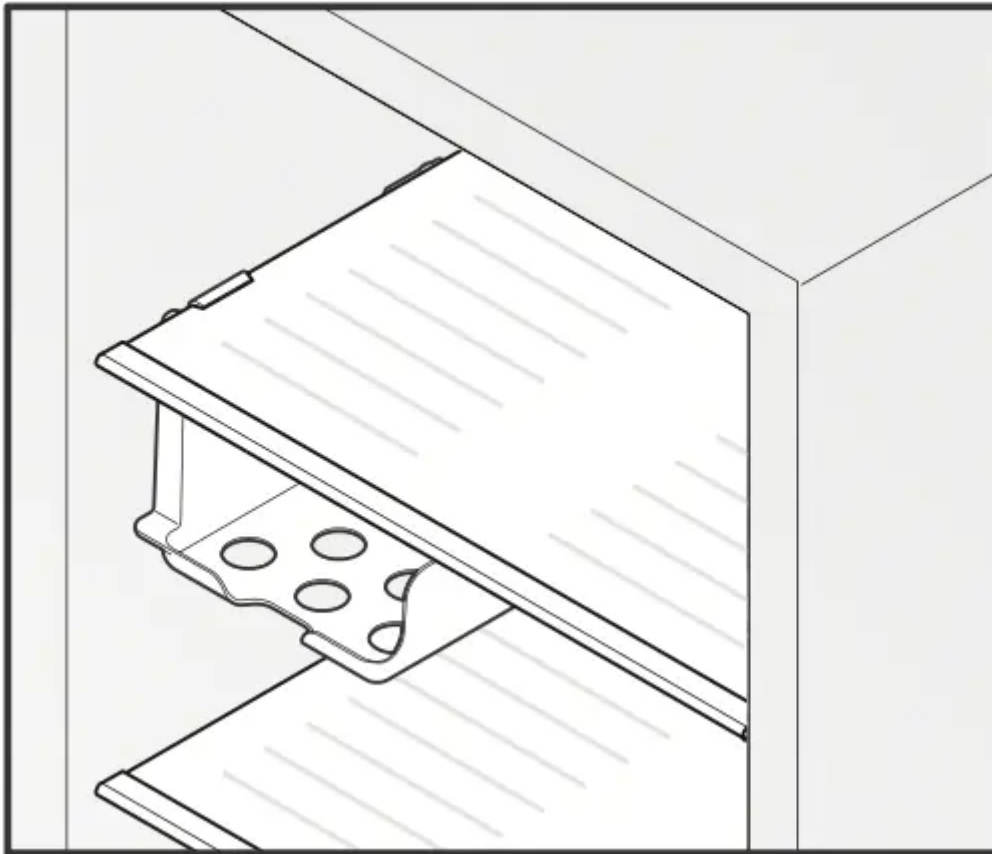

Pizza Shelf (Some Upright Models)

Here is the place to store up to four extra-large boxes of frozen pizza without ever having to dig them out from beneath a pile of other stored goods. To change the location of the pizza shelf: support the bottom center of the shelf with one hand and use your other hand to gently ease each support tab outward until they have all dropped between the edge of the shelf and the liner wall. It may help to slide the supporting shelf slightly to the side opposite that in which you are removing the tabs in order to get a larger gap between the edge of the supporting shelf and the liner wall.

Next, locate the pizza shelf beneath the shelf nearest your desired location and snap each tab upwards between the wire or glass shelf and liner until the tab has snapped into place and is resting on top of the supporting shelf. Repeat for each tab until all four are firmly in place and then load with desired items.

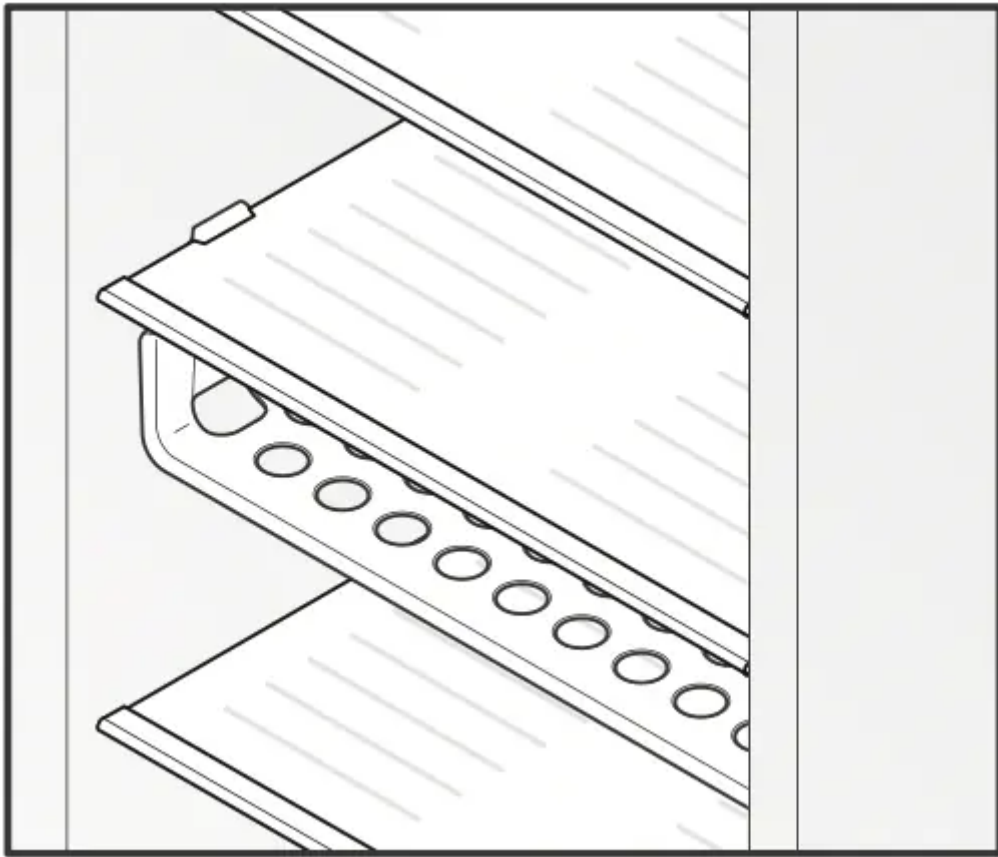

Chest Divider (Some Chest Models)

Use these clever dividers to custom-arrange a variety of differentsized storage bins in the bottom of your chest freezer. Use the peel-n-stick labels found in your literature packet to help remind you which items are stored where. If you have an item that isn't already covered by one of the pre-printed labels then use one of the blank labels and a permanent marking pen to make your own custom label. Labels can be peeled off when no longer needed and replaced by new and different ones.

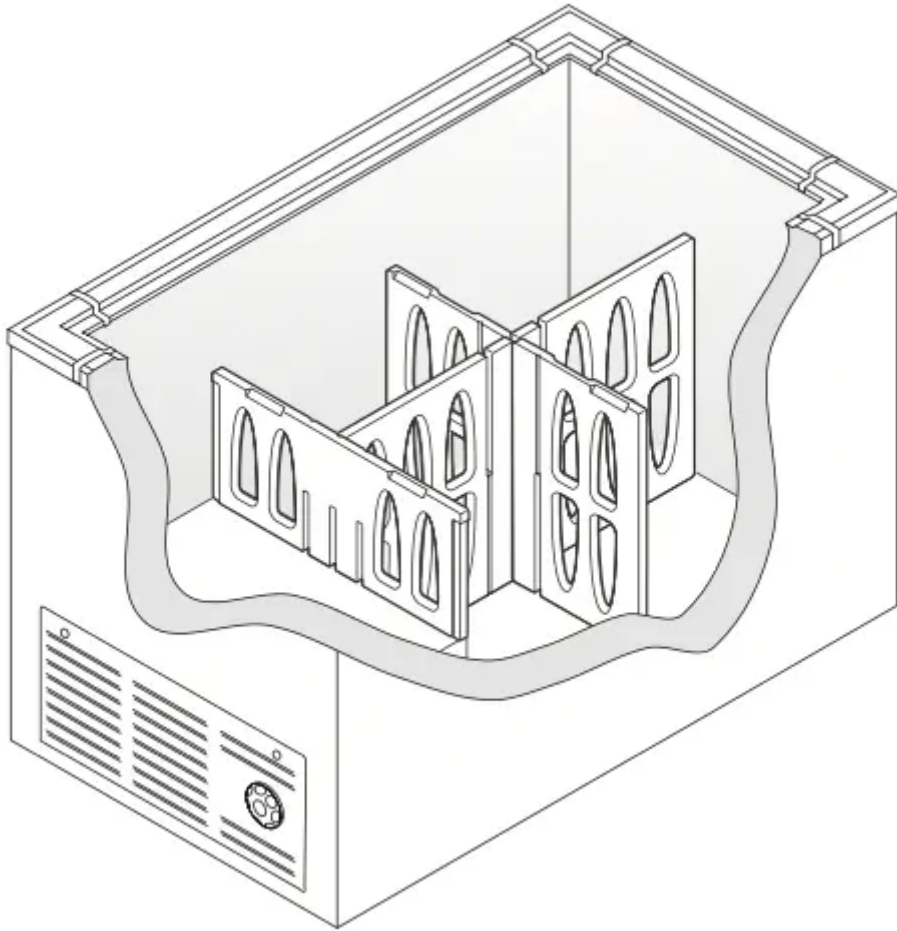

Examples of Chest Divider Configurations:

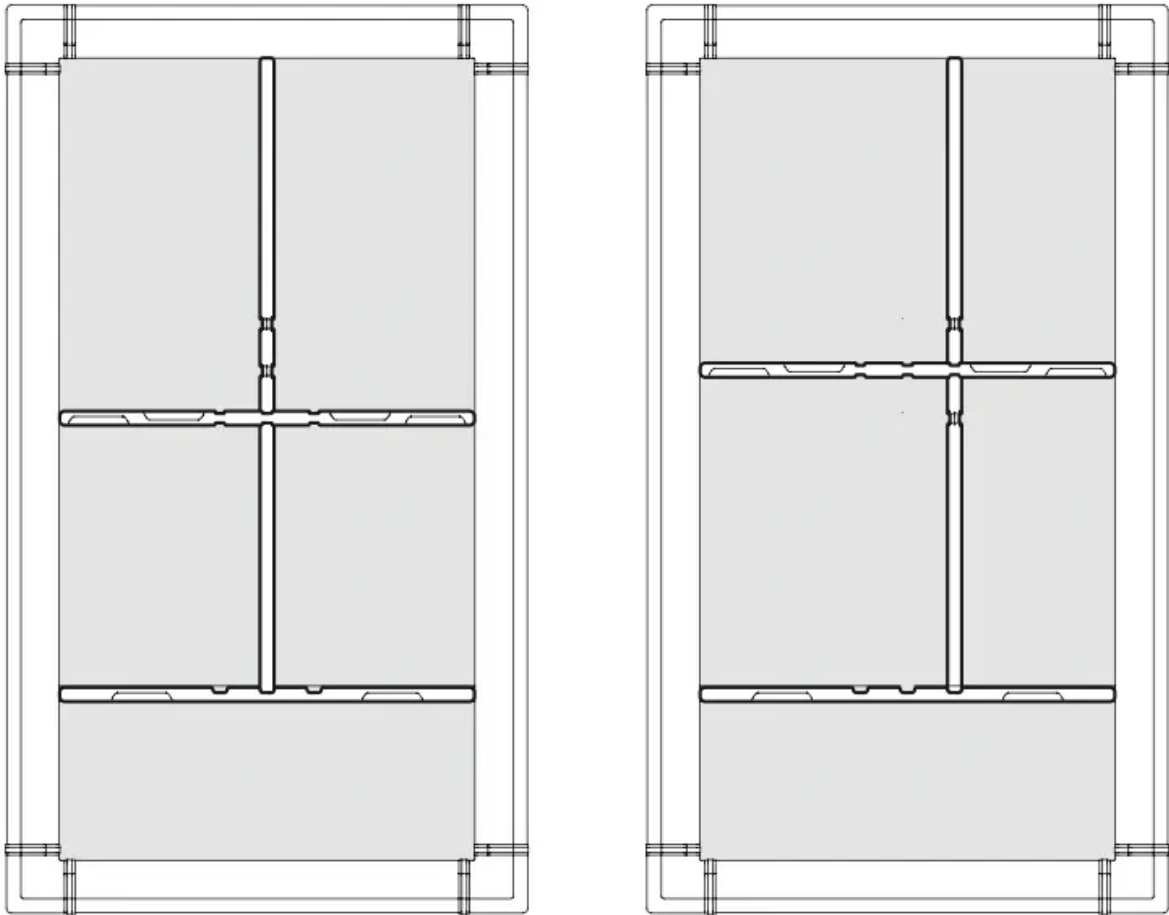

Compressor Mounted Drain Pan (Most Upright Frost Free Models)

Most upright frost free freezers are equipped with a compressor mounted drain pan that collects condensate during each defrost cycle. This compressor mounted drain pan takes advantage of the heat generated by the compressor to evaporate condensate water so there is no need to empty the pan during each defrost cycle.

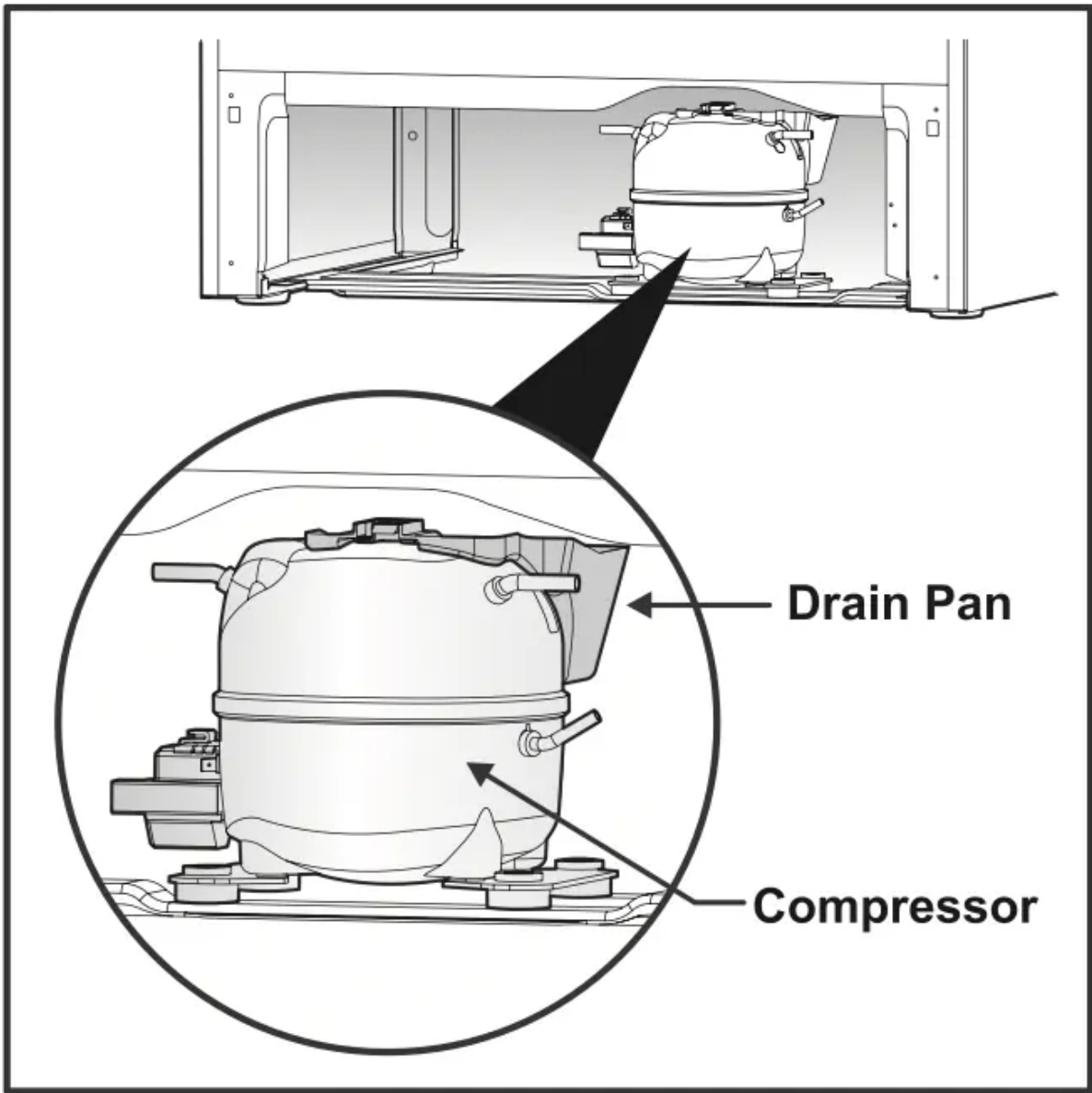

Care and Cleaning

- Damp objects stick to cold metal surfaces. DO NOT touch interior metal surfaces with wet or damp hands.
- The freezer must be unplugged (to avoid electrical hazard) from power source when defrosting the unit.

Some upright and chest freezers are frost free and defrost automatically, but should be cleaned occasionally.

Between Defrostings

To avoid frequent defrosting, occasionally use a plastic scraper to remove frost. Scrape with pulling motion. NEVER use a metal instrument to remove frost.

Defrosting

It is important to defrost and clean the freezer when $\frac{1}{4}$ to $\frac{1}{2}$ inch of frost has accumulated. Frost may tend to accumulate faster on the upper part of the freezer due to warm, moist air entering the freezer when the door/lid is opened. Remove food and leave the door/lid open when defrosting the freezer.

To Defrost Upright Models with Defrost Drain:

- Remove the drain plug on the inside floor of the freezer by pulling it straight out.
- To access external drain tube on models with a base panel, first remove the two screws from the base panel. Locate the drain tube near the left center under the freezer.
- Place a shallow pan under the drain tube. Defrost water will drain out. Check the pan occasionally so water does not overflow (see figure 1).
- A $\frac{1}{2}$ inch garden hose adapter can be used to drain the freezer directly into a floor drain. If your model is not equipped with an adapter, one can be purchased at most hardware stores.
- Replace the drain plug when defrosting and cleaning are completed. If the drain is left open, warm air may enter the freezer.

To Defrost Chest Models with Defrost Drain:

- Place a shallow pan or the Divider/Drain Pan (if equipped) beneath the drain outlet. Pull out the outside drain plug (see figure 2). A $\frac{1}{2}$ inch garden hose adapter can be used to drain the freezer directly into a floor drain (see figure 3). If your model is not equipped with an adapter, one can be purchased at most hardware stores.
- Pull out the drain plug inside the freezer (see figure 4). Defrost water will drain out. Check pan occasionally so water does not overflow.
- Replace the drain plugs when defrosting and cleaning are completed. If the drain is left open, warm air may enter the freezer.

To Defrost Models without Defrost Drain:

- Place towels or newspapers on the freezer bottom to catch the frost. The frost will loosen and fall.
- Remove the towels and/or newspapers.
- If the frost is soft, remove it by using a plastic scraper. If the frost is glazed and hard, fill deep pans with hot water and place them on the freezer bottom.
- Close the freezer door/lid. Frost should soften in about fifteen (15) minutes.
- Repeat this procedure is necessary.

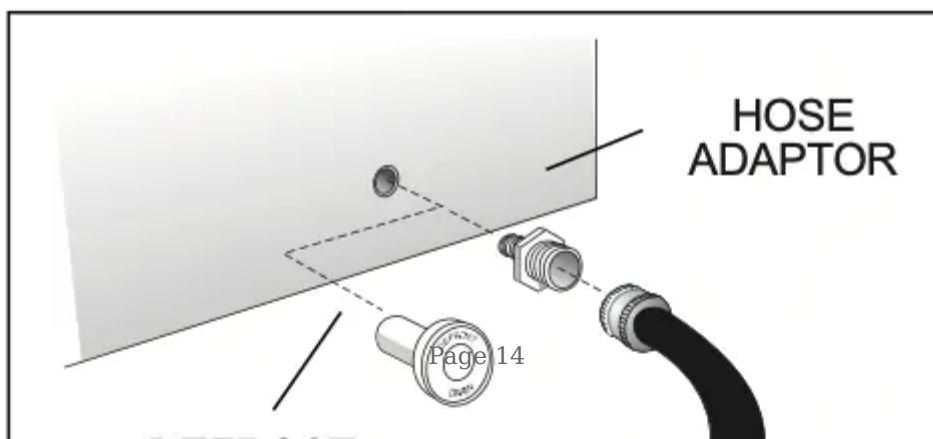
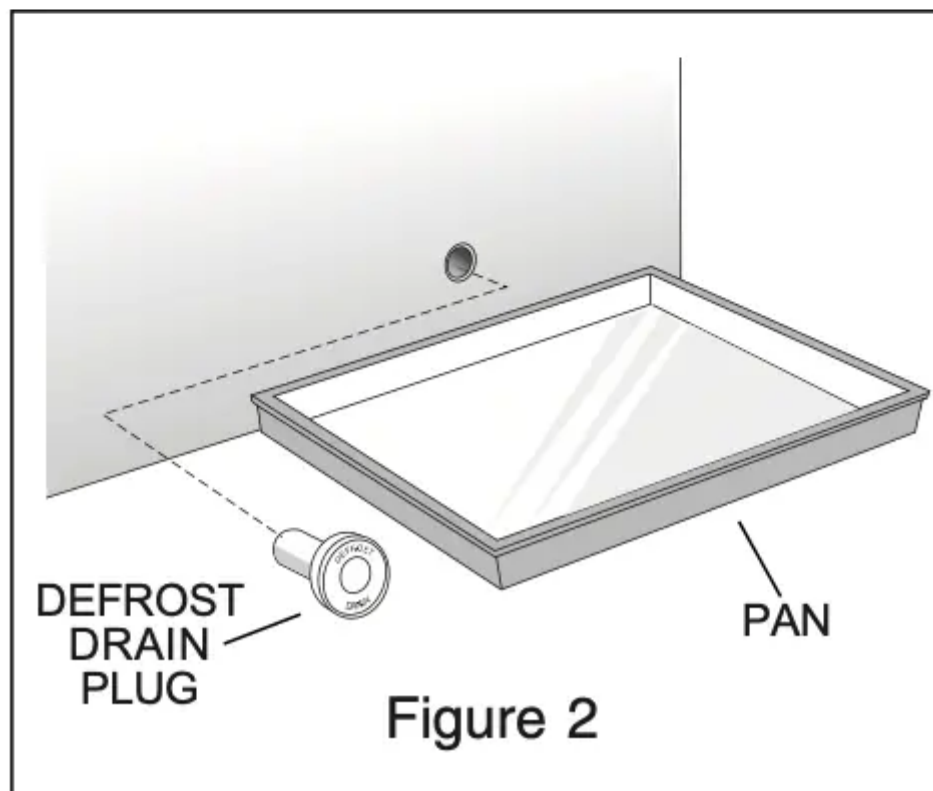
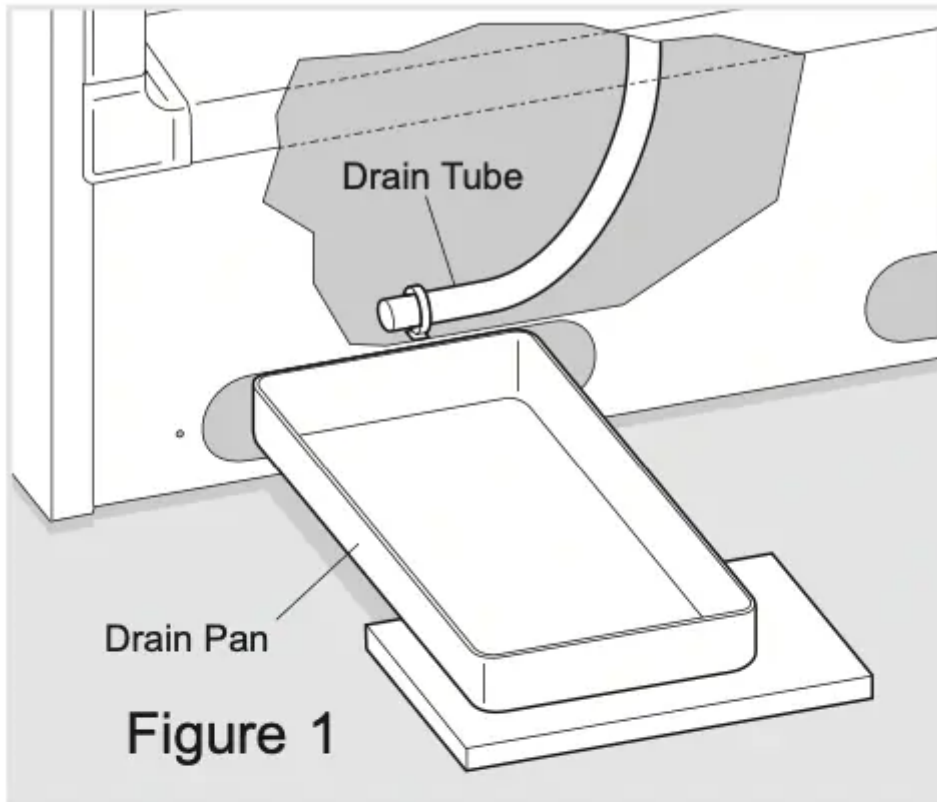

Cleaning The Inside

After defrosting, wash inside surfaces of the freezer with a solution of two (2) tablespoons of baking soda in one (1) quart (1.136 liters) warm water. Rinse and dry. Wring excess water out of the sponge or cloth when cleaning in the area of the controls, or any electrical parts.

Wash the removable parts with the baking soda solution mentioned above, or mild detergent and warm water. Rinse and dry. NEVER use metallic scouring pads, brushes, abrasive cleaners or alkaline solutions on any surface. DO NOT wash removable parts in a dishwasher.

Cleaning The Outside

Wash the cabinet with warm water and mild liquid detergent. Rinse well and wipe dry with a clean soft cloth. Replace parts and food.

Do not use razor blades or other sharp instruments, which can scratch the freezer surface when removing adhesive labels. Any glue left from the tape can be removed with a mixture of warm water and mild detergent, or touch the residue with the sticky side of the tape already removed. DO NOT REMOVE THE SERIAL PLATE.

Power Failure / Freezer Failure

WARNING - Risk of Child Entrapment: If leaving the freezer door/lid open while on vacation, make certain that children cannot get into the freezer and become entrapped. DO NOT open freezer door/lid unnecessarily if freezer is off for several hours.

Vacation and Moving Tips

Short Vacations:

- Leave the freezer operating during periods of non-use of less than three (3) weeks.

Long Vacations:

If the freezer will not be used for several months:

- Remove all food and unplug the power cord.
- Clean and dry the interior thoroughly.
- Leave the freezer door/lid open slightly, blocking it open if necessary, to prevent odor and mold growth.

Moving:

When moving the freezer, follow these guidelines to prevent damage:

- Disconnect the power cord plug from the wall outlet.
- Remove foods, then defrost, and clean the freezer.

- Secure all loose items such as base panel, baskets, and shelves by taping them securely in place to prevent damage.
- In the moving vehicle, secure freezer in an upright position to prevent movement. Also, protect outside of freezer with a blanket or similar item.

IF A POWER FAILURE OCCURS:

Frozen foods will stay frozen for at least 24 hours if the freezer is kept closed. If the power failure continues, pack seven or eight pounds of dry ice into the freezer every 24 hours. Look in the Yellow Pages under “Dry Ice”, “Dairies”, or “Ice Cream Manufacturers” for local dry ice suppliers. Always wear gloves and use caution when handling dry ice.

If the freezer has stopped operating, see the “Freezer does not run” section in the Avoid Service Checklist section of this use and care guide. If you cannot solve the problem, call an authorized service personnel immediately.

If the freezer remains off for several hours, follow the directions above for the use of dry ice during a power failure. If necessary, take the food to a local locker plant until the freezer is ready to operate. Look in the Yellow Pages under “Frozen Food Locker Plants”.

PROBLEM	CAUSE	CORRECTION
FREEZER DOES NOT RUN.		
Freezer does not run.	Freezer is plugged into a circuit that has a ground fault interrupt.	Use another circuit. If you are unsure about the outlet, have it checked by a certified technician.
	Temperature control is in the "OFF" position.	See Thermostat Setting.
	Freezer may not be plugged in, or plug may be loose.	Ensure plug is tightly pushed into outlet.
	House fuse blown or tripped circuit breaker.	Check/replace fuse with a 15 amp time delay fuse. Reset circuit breaker.
	Power outage	Check house lights. Call local Electric Company.
Freezer runs too much or too long.	Room or outside weather is hot.	It's normal for the freezer to work harder under these conditions.
	Freezer has recently been disconnected for a period of time.	It takes 24 hours for the freezer to cool down completely.
	Large amount of warm or hot food have been stored recently.	Warm food will cause freezer to run more until the desired temperature is reached.
	Door/lid is opened too frequently or kept open too long.	Warm air entering the freezer causes it to run more. Open the door/lid less often.



	Freezer door/lid may be slightly open.	See "Door/lid Problems".
	Temperature control is set too low.	Turn control knob to a warmer setting. Allow several hours for the temperature to stabilize.
	Freezer gaskets are dirty, worn, cracked or poorly fitted.	Clean or change gasket. Leaks in the door/lid seal will cause freezer to run longer in order to maintain desired temperature.
Interior freezer temperature is too cold.	Temperature control is set too low.	Turn control knob to a warmer setting. Allow several hours for the temperature to stabilize.
Interior freezer temperature is too warm.	Temperature control is set too warm.	Turn control knob to a colder setting. Allow several hours for the temperature to stabilize.
	Door/lid is opened too frequently or kept open too long.	Warm air entering the freezer causes it to run more. Open the door/lid less often.
	Freezer door/lid may be slightly open.	See "Door/lid Problems".
	Large amount of warm or hot food have been stored recently.	Wait until the freezer has had a chance to reach its selected temperature.
	Freezer has recently been disconnected for a period of time.	Freezer requires 24 hours to cool down completely.



Freezer external surface temperature is warm.	The external freezer walls can be as much as 30°F warmer than room temperature.	This is normal while the compressor works to transfer heat from inside the freezer cabinet.
SOUND AND NOISE		
Louder sound levels whenever freezer is on.	Modern freezers have increased storage capacity and more stable temperatures. They require high efficiency compressors.	This is normal. When the surrounding noise level is low, you might hear the compressor running while it cools the interior.
Louder sound levels when compressor comes on.	Freezer operates at higher pressures during the start of the ON cycle.	This is normal. Sound will level off or disappear as freezer continues to run.
Popping or cracking sound when compressor comes on.	Metal parts undergo expansion and contraction, as in hot water pipes.	This is normal. Sound will level off or disappear as freezer continues to run.
Bubbling or gurgling sound,	Refrigerant (used to cool freezer) is circulating throughout the system.	This is normal.
Vibrating or rattling noise.	Freezer is not level. It rocks on the floor when it is moved slightly.	Level the freezer by putting wood or metal shims under part of the freezer.
	Floor is uneven or weak.	Ensure floor can adequately support freezer. Level the freezer by putting wood or metal shims under part of the freezer.
	Freezer is touching the wall.	Re-level freezer or move freezer slightly.
WATER / MOISTURE / FROST INSIDE FREEZER		



Moisture forms on inside freezer walls.	Weather is hot and humid, which increases internal rate of frost buildup.	This is normal.
	Door/lid is slightly open.	See "Door/lid Problems".
	Door/lid is kept open too long or is opened too frequently.	Open the door/lid less often.
WATER / MOISTURE / FROST OUTSIDE FREEZER		
Moisture forms on outside freezer walls.	Door/lid is slightly open.	See "Door/lid Problems".
ODOR IN FREEZER		
Odors in freezer.	Interior needs to be cleaned.	Clean interior with sponge, warm water, and baking soda.
	Foods with strong odors are in the freezer.	Cover the food tightly.
DOOR/LID PROBLEMS		
Door/lid will not close.	Freezer is not level. It rocks on the floor when it is moved slightly.	Level the freezer by putting wood or metal shims under part of the freezer.
	Floor is uneven or weak.	Ensure floor can adequately support freezer. Level the freezer by putting wood or metal shims under part of the freezer.
LIGHT BULB IS NOT ON		
Light bulb is not on.		



	The fluorescent lamp or light bulb is burned out.	See "Fluorescent Lamp" or "Interior Light" on Features Section.
	No electric current is reaching the appliance.	See "Freezer Does Not Run".
AUTOMATIC ICE MAKER NOT WORKING (IF EQUIPPED)		
Automatic ice maker not working (some models).	Ensure the Wire Signal Arm is not in the "UP" position.	
	Ice maker should produce 4 to 5 pounds of ice in a 24 hour period.	
	Water supply is turned off.	
	Water pressure is too low.	
	The freezer is not cold enough.	

Warning

This content is compiled from multiple sources and is provided for reference purposes only. It may not be complete or fully applicable to all situations. If you are unable to resolve your issue, please contact the product manufacturer or an authorized service provider for official support.

