

ABOUT THE SHARK ION™ ROBOT

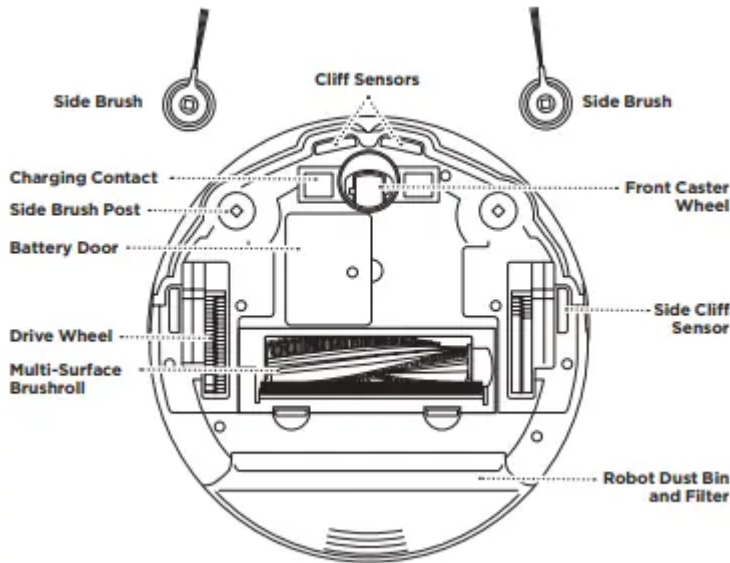

ABOUT THE SHARK ION™ ROBOT

With Auto-Sense™ Navigation, your robot uses an array of sensors to navigate around walls, furniture legs, and other obstacles while it cleans. The robot may gently bump into obstructions or linger in one spot, and it may not cover every area in a single cleaning. For best results, prepare your home as indicated below, and schedule a daily cleaning to ensure all floor areas are regularly maintained.

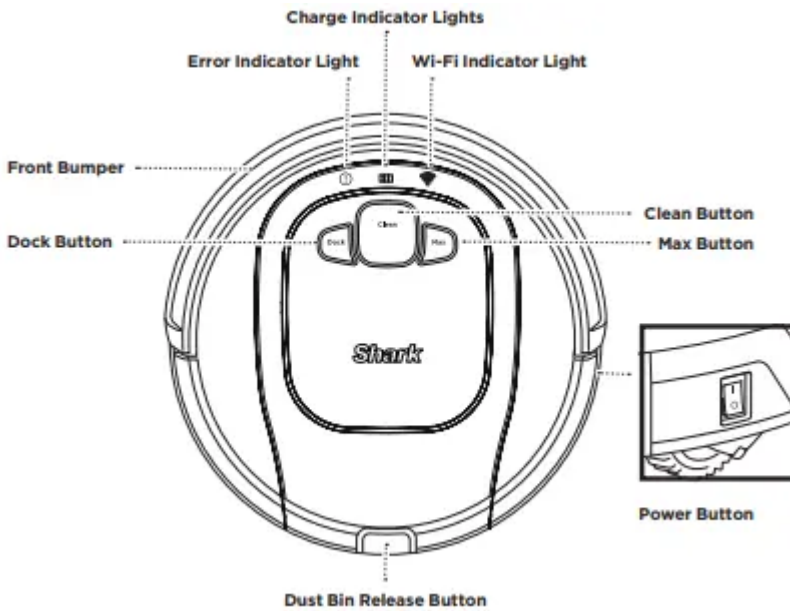

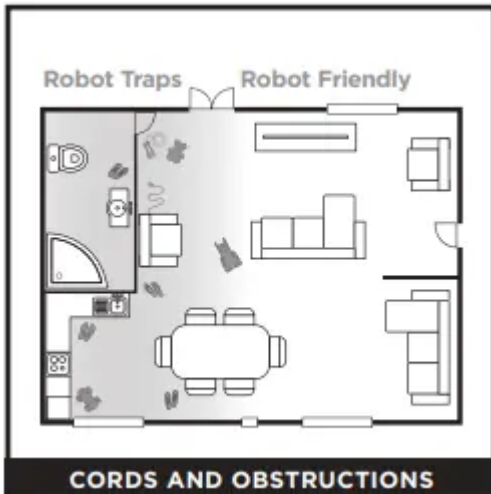

Before cleaning, clear away cords and other obstructions or block off the area with the included BotBoundary® Strips.



To prevent your robot from becoming trapped, use furniture risers or BotBoundary strips.

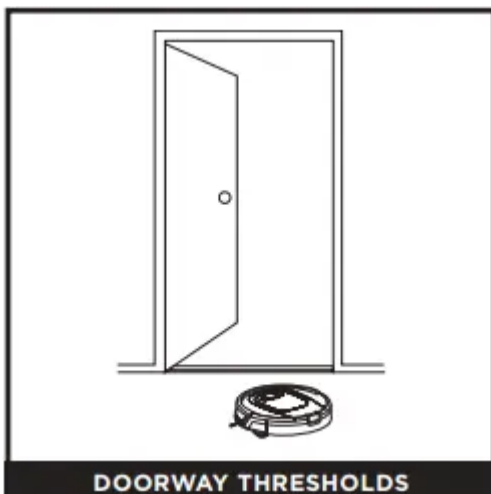

Your robot may have some trouble clearing some high thresholds. Block off high thresholds with BotBoundary strips.



If your robot roams too far, it could have trouble finding the Charging Dock. It may be helpful to block off part of your home with BotBoundary strips, or to add a second dock.

PREPARING FOR USE

INSTALLING THE SIDE BRUSHES

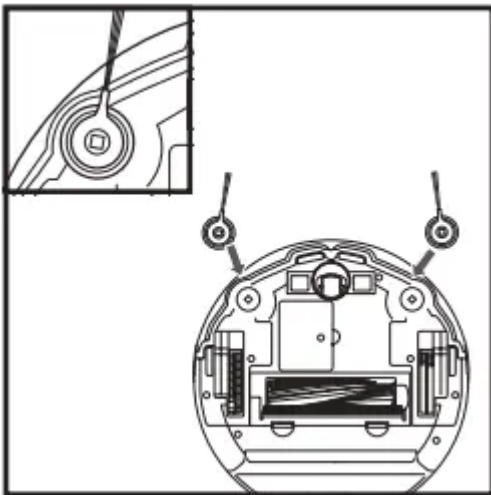

Snap the 2 included Side Brushes onto the square posts on the bottom of the robot.

CHARGING DOCK SET-UP

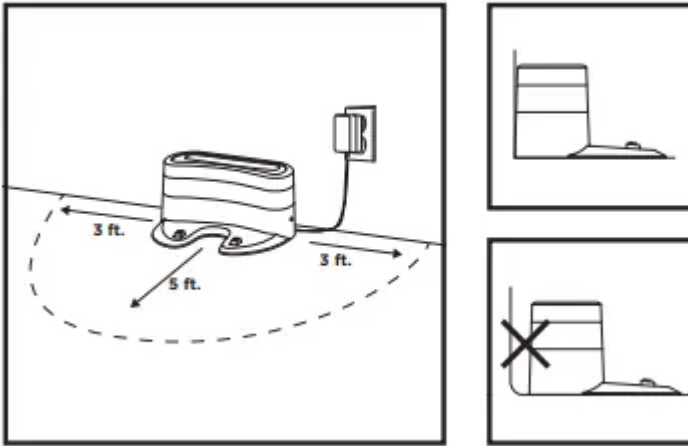

Place the charging dock on a level surface with its back against a wall, in a space without obstructions, that can easily be accessed by your robot. Remove any objects that are closer than 3 feet (1 meter) from either side of the dock, or closer than 5 feet (1.52 meters) from the front of the dock. Plug the Charging Adapter into a wall outlet. The dock must be plugged in continually for the robot to find it. The LED indicator on the dock turns green when powered on. The robot will beep when it starts charging on the dock.

CHARGING THE SHARK ION™ ROBOT

CHARGING

IMPORTANT: The Shark ION Robot has a pre-installed rechargeable battery. Battery must be fully charged before using.

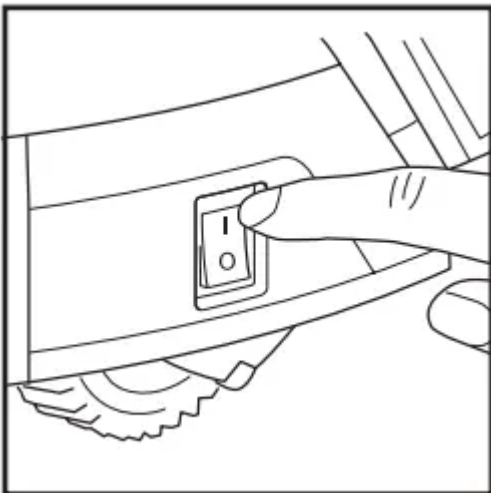

To charge, the Power button on the side of the robot must be in the ON position (I).



When the cleaning cycle is complete, or if the battery is running low, the robot will search for the dock. If your robot doesn't return to the dock, its charge may have run out.



If the robot has no charge and cannot return to the charging dock, place it on the dock manually.

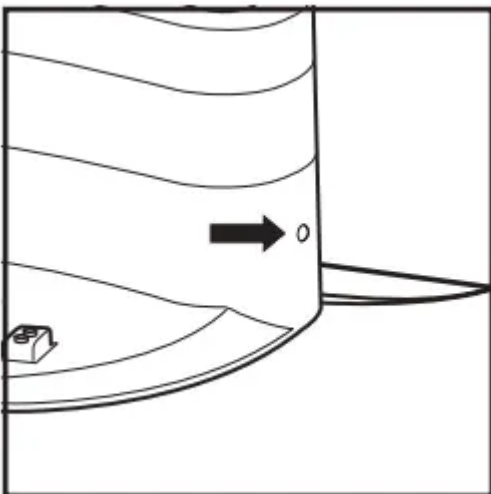

The LED on the side of the dock will be green when the dock is powered. When the robot is placed on the dock the LED will turn blue.

NOTE: When manually placing the robot on the dock, make sure the Charging Contacts on the bottom of the robot are aligned with the dock. To ensure the robot is docked correctly, refer to the Charge Indicator Lights section.

CHARGING THE SHARK ION™ ROBOT

CHARGE INDICATOR LIGHTS

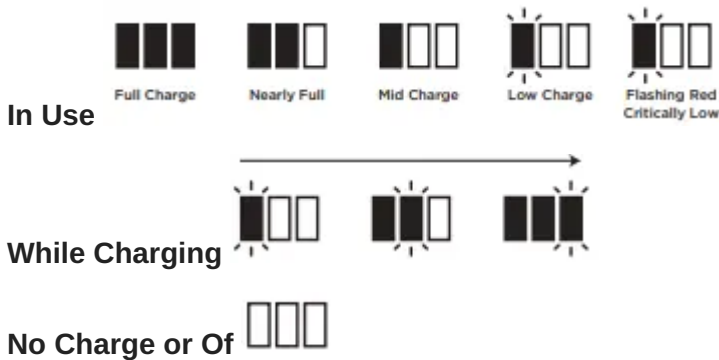
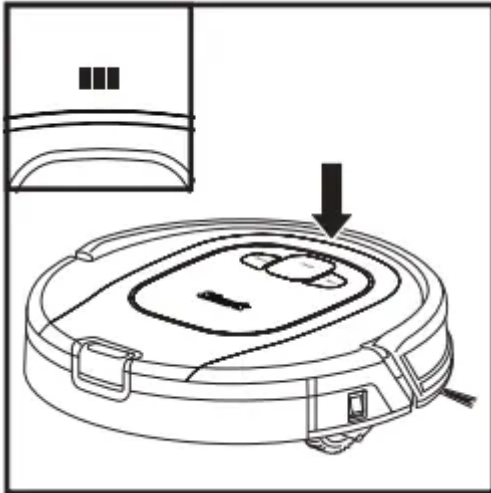

The blue charge indicator lights show how much charge is remaining.

While the robot is charging, all three blue LED lights will cycle. When charging is complete, all three blue lights will illuminate steadily.

If the robot is idle and away from the charging dock for 10 minutes, it will enter Sleep Mode, and the lights will turn off and these indicator lights will turn off, but Clean will remain lit. Wake up the robot by pressing any button.

NOTE: If the low charge light is blinking red, there is not enough charge for the robot to return to the dock. Manually place the robot on the dock.

TIP: To preserve battery life, turn off the power switch if robot will not be used for a long period of time. Unit should be recharged at least once every three months.

IMPORTANT: Before cleaning an entire room for the first time, we recommend that you first test your robot on a small section of the floor to ensure there is no scratching.

USING THE SHARK ION™ ROBOT

BUTTONS AND INDICATOR LIGHTS

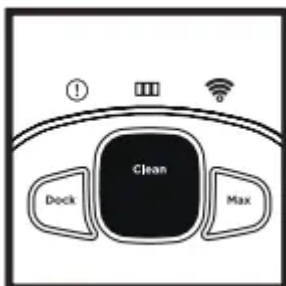
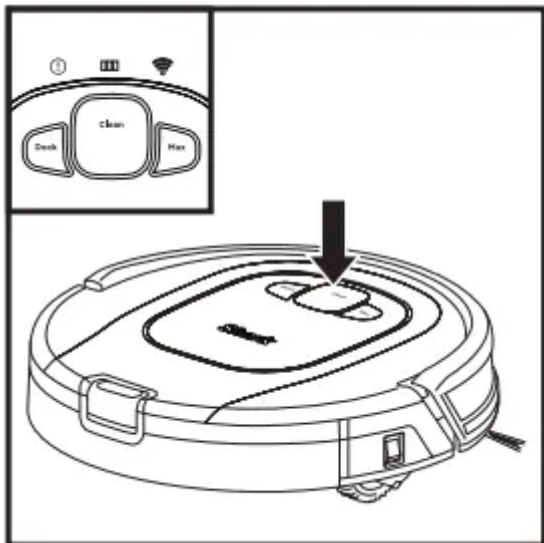

CLEAN BUTTON

Press to begin a cleaning session. Press again to stop.

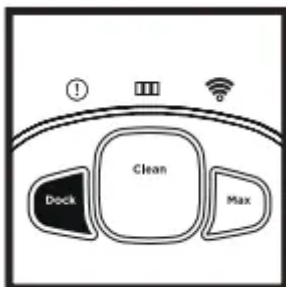

DOCK BUTTON

Press to stop cleaning and send robot back to the charging dock.





MAX BUTTON

Press for more powerful cleaning.

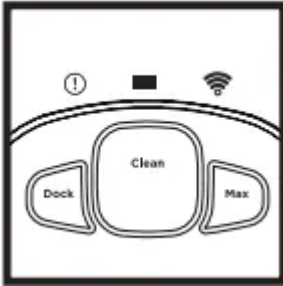

CHARGE INDICATOR LIGHTS

Display the amount of charge remaining in the battery.

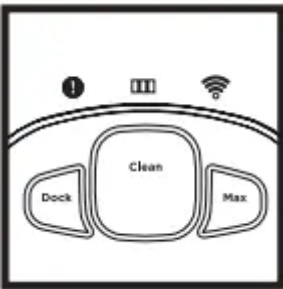

“!” ERROR INDICATOR

See Troubleshooting section for full list of error codes.

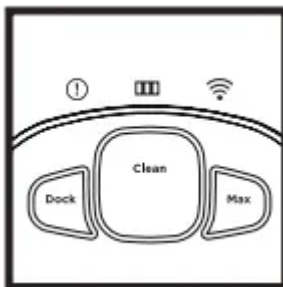

WI-FI INDICATOR

Blue light: connected to Wi-Fi.

Red light: not connected. Flashing blue: setup mode. No light: not set up yet.

USING THE SHARK ION™ ROBOT

USING THE SHARK CLEAN™ APP AND VOICE CONTROLS

The Shark Clean app will guide you through easy setup of your robot.

Control the unit remotely:

- Schedule cleaning times for up to 7 days a week.
- Start, stop, or dock your robot from your phone anywhere with Wi-Fi connectivity.

The app will also provide you access to:

- Tips, Tricks, and FAQs
- Tech Support
- Troubleshooting

Search for Shark Clean in the app store and download the app to your iPhone™ or Android™.



USING THE SHARK ION™ ROBOT

SETTING UP THE SHARK CLEAN™ APP

Download the latest version of the Shark Clean app from the App Store or Google Play store.

- Follow instructions on the app to connect to the robot.

To ensure the app successfully pairs with the robot:

- Confirm your Wi-Fi router and/or home network supports a 2.4 GHz network.
- Confirm your Wi-Fi network name.
- Confirm your Wi-Fi network password.

USING THE SHARK ION™ ROBOT

BotBoundary® strips

To keep your robot away from certain areas, such as pet bowls, fragile objects, power strips, or doorways, use the BotBoundary strips to quickly and easily create “no-go zones”.

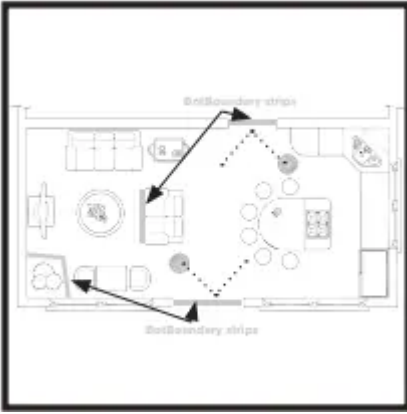

Identify areas or objects you want the robot to avoid.

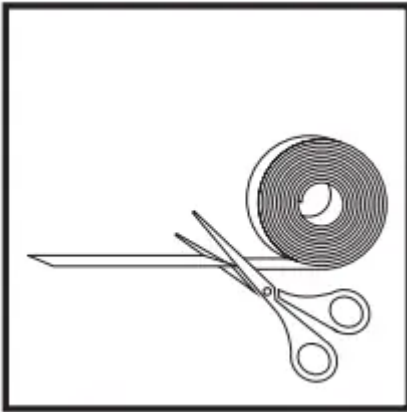

Cut the BotBoundary strip to the desired length (18"/45cm minimum) so that it spans the length of the doorway or object you want to block off.

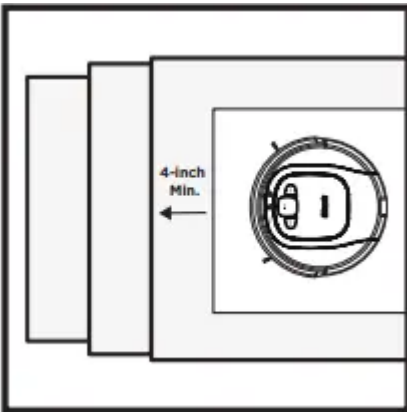

Generally, BotBoundary strips are not needed on stairs because your robot's cliff sensors will prevent it from falling off ledges. For your robot's cliff sensors to work properly, all runners, rugs, or carpets must be at least 4 inches from any stairs (or extend over the edge of the stairs.)

If a runner, rug, or carpet edge is less than 4 inches from the stairs and can't be moved, use a BotBoundary strip to block off the stairs.

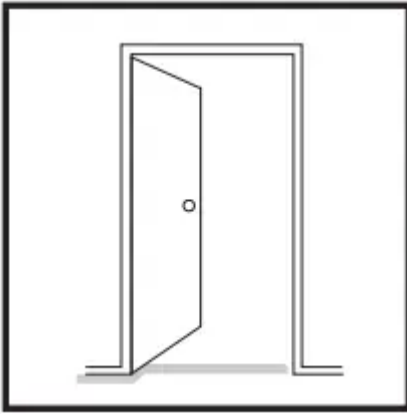

For best results, make sure your BotBoundary strip is completely flat against the floor. Make a closed loop around an object, or place the strips between fixed objects, like door frames or the legs of a couch, to create no-go zones.

NOTE: To prevent bumping, place strips at least 2 inches in front of the object you want to block off.

MAINTENANCE

CAUTION: Turn off power before performing any maintenance.



EMPTYING THE ROBOT DUST BIN

EMPTY DUST BIN AFTER EACH USE.

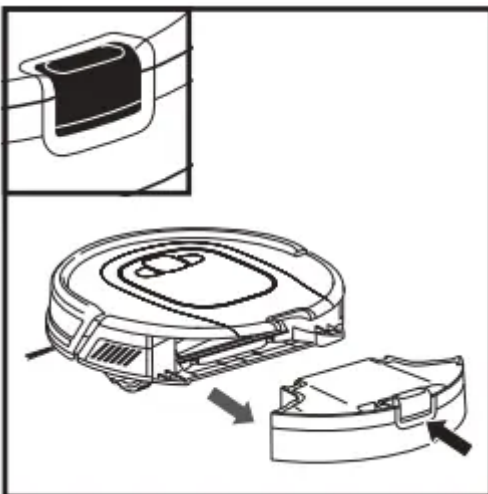

Press the Dust Bin Release Button and slide out the dust bin.

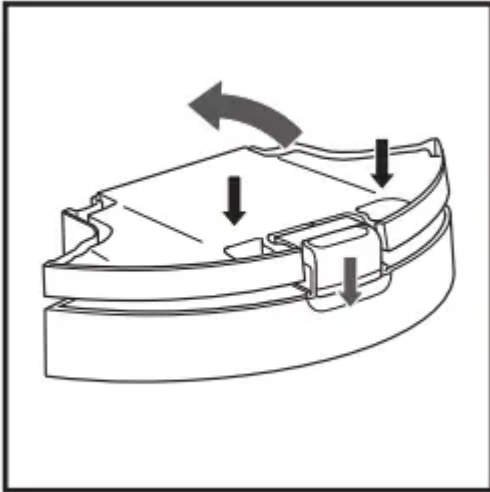

To open the dust bin lid, press and hold the button while lifting the lid, using the finger slots.



Empty debris and dust into trash.

CLEANING THE FILTER

CLEAN FILTER EVERY WEEK.

REPLACE FILTER EVERY TWO MONTHS. See sharkaccessories.com for replacement filters.

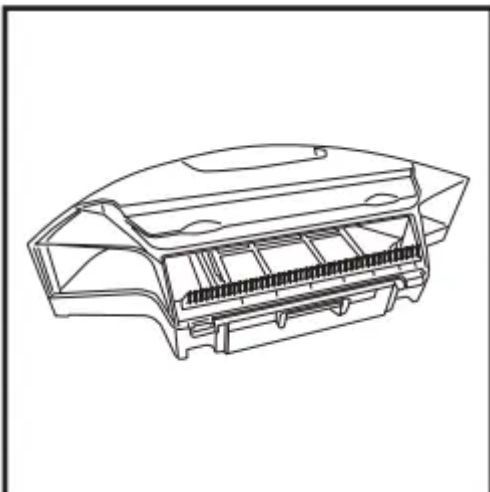

Remove and empty the dust bin. Clean any hair or debris off the Anti-Tangle Comb on the back of the dust bin.

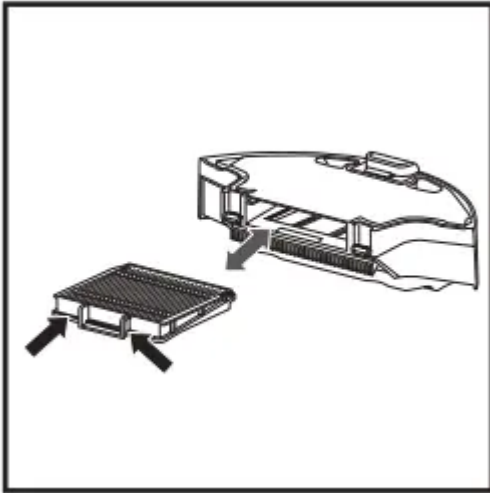

Pull filter out of the dust bin by the tabs.

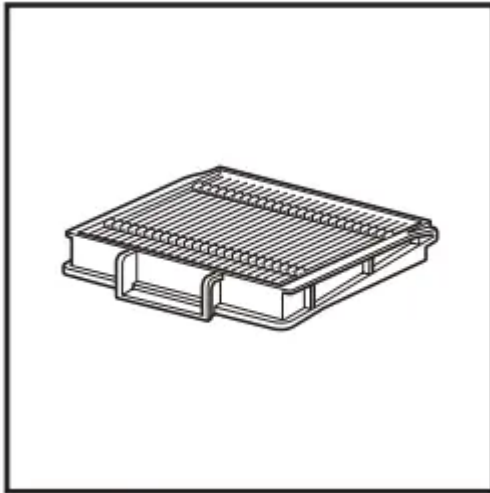

Lightly tap the filter to remove dust and debris.

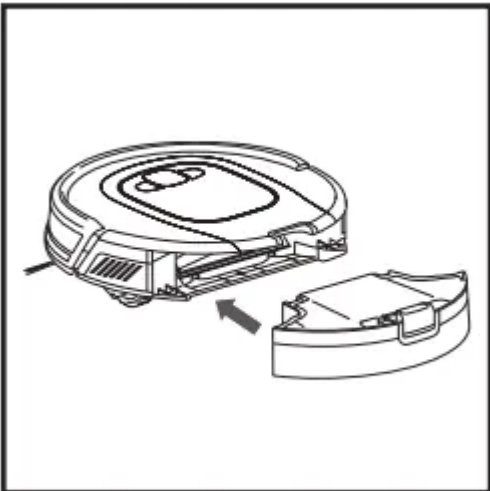

Reinsert the filter into the dust bin. Slide the dust bin back into the robot.

CLEANING THE MULTI-SURFACE BRUSHROLL

THE BRUSHROLL NEEDS OCCASIONAL MAINTENANCE.

REPLACE BRUSHROLL EVERY 6 to 12 MONTHS, OR WHEN VISIBLY WORN. See sharkaccessories.com for replacement parts.

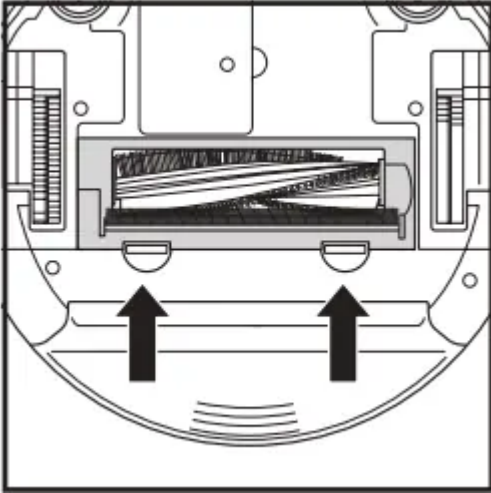

Push up on the tabs on the brushroll access door, then lift off the door.

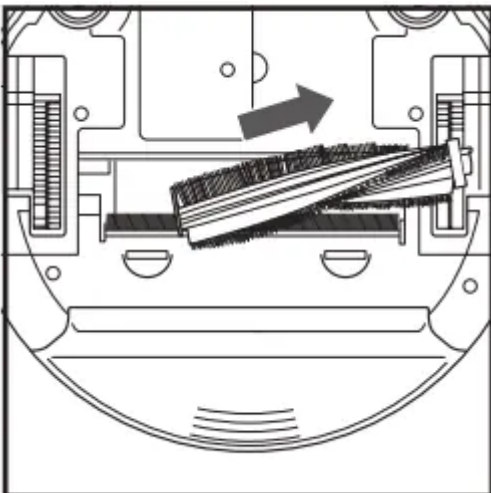

Lift out the brushroll.



Remove the blue cap on the end of the brushroll. Do not let the metal cylinder inside the cap fall out. Clean off any hair or debris, then replace cap. Clean the brushroll periodically and whenever hair appears.

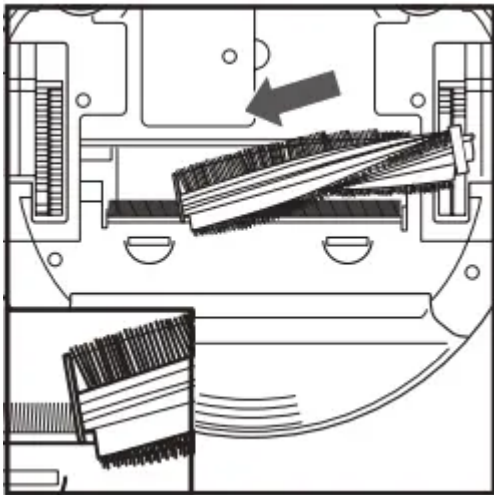

Reinstall the brushroll, inserting the flat end first. Close the brushroll access door and press down until it clicks into place.

NOTE: If the metal cylinder falls out of the brushroll cap, reinsert it in the hole on the inside of the cap. When cutting away debris, be sure not to cut the brushroll or any other parts of the robot.

CLEANING SENSORS AND CHARGING PADS

CLEAN SENSORS AND CHARGING PADS PERIODICALLY AS NEEDED. With a dry cloth or cleaning brush, gently dust off the sensors and pads located on the bottom of the robot.

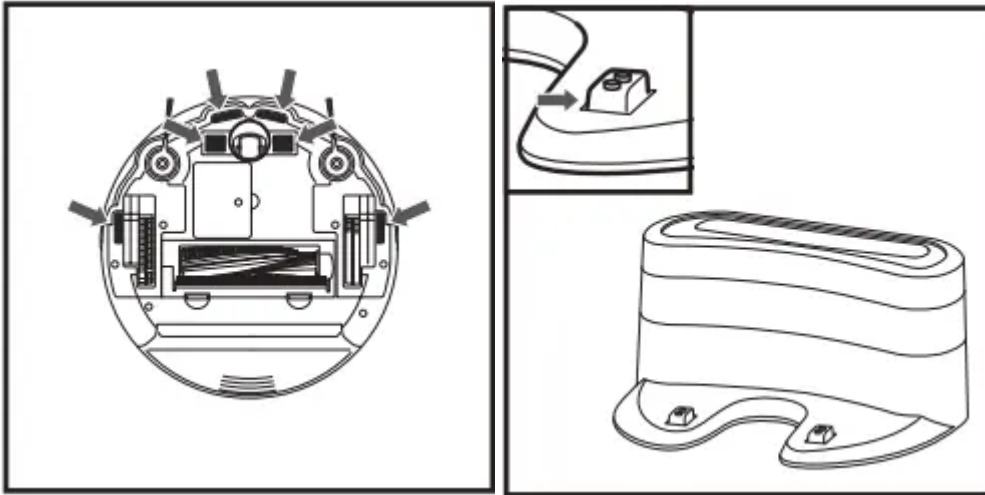

IMPORTANT: The robot uses cliff sensors to avoid stairs and other steep drops. Sensors may work less effectively when they are dirty. For best results, clean sensors regularly.

CLEANING SIDE BRUSHES

CLEAN SIDE BRUSHES AS NEEDED. CHECK WEEKLY.

RECOMMENDED REPLACEMENT SCHEDULE: Replace when visibly worn. See sharkaccessories.com for replacement parts.

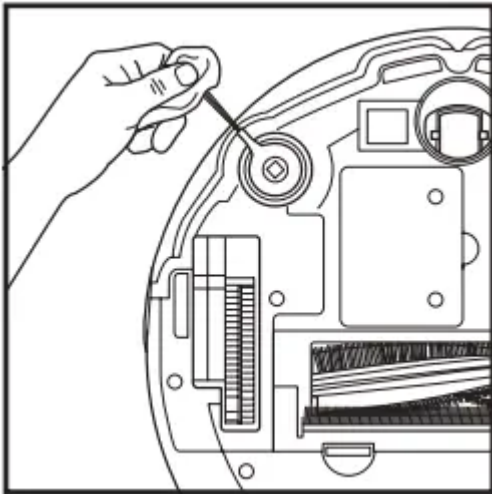

Carefully unwind and remove any string or hair wrapped around brushes.

Gently wipe brushes with a damp cloth. Be sure to let them air-dry completely before reinstalling them.

NOTE: Remove any side brushes that are bent or damaged. To remove a brush, lift it off its peg. See [Installing the Side Brushes](#) for instructions on how to attach and remove the brushes.

CLEANING THE WHEELS

REMOVE AND CLEAN FRONT WHEEL EVERY WEEK. REPLACE FRONT WHEEL EVERY 12 MONTHS. See sharkaccessories.com for replacement parts.

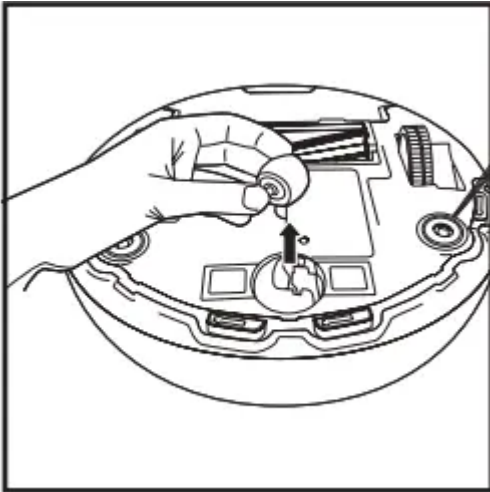

Pull the Front Caster Wheel from its housing and remove any debris buildup.

NOTE: Leverage may be required to remove the wheel.

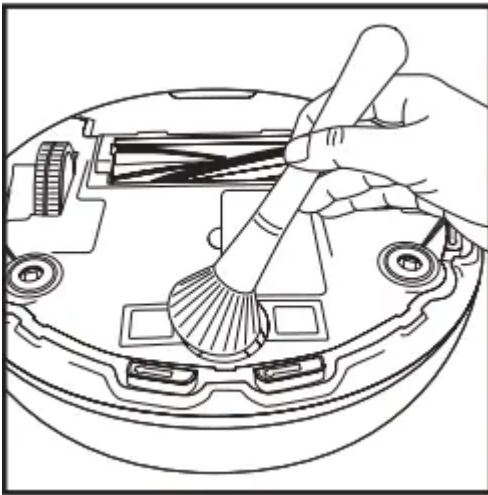

Clean the wheel housing, then reinsert the caster wheel.

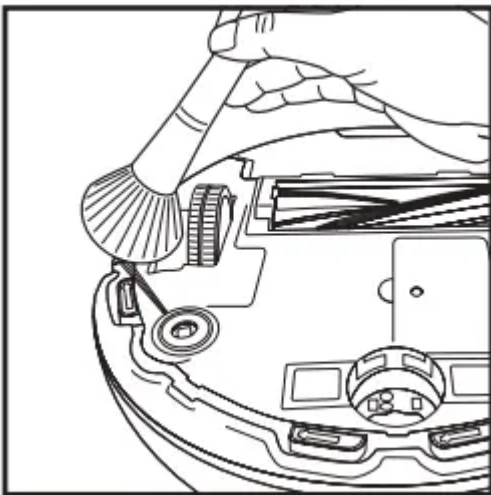

Periodically clean the drive wheels and the housing around them. To clean, rotate each drive wheel while dusting.

REPLACING THE BATTERY

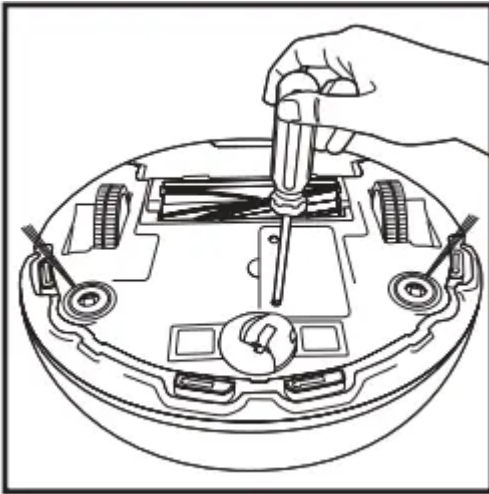

To remove the battery, turn the unit over and unscrew the battery cover with a Phillips-head screwdriver.

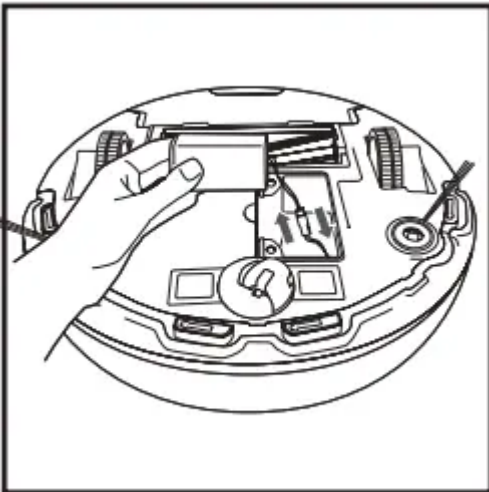

Unplug the old battery from its connector, then plug in the new battery. Replace battery cover and screw it back into place. See Battery Removal and Disposal on back cover.

TROUBLESHOOTING

If any error lights are illuminated or flashing on your Shark ION™ Robot, see the error code chart below:

ALL LED LIGHTS are off

The robot is in Sleep Mode, the power switch is turned off (O) or there is no charge remaining. Turn the power switch ON (I). Press any button to ensure robot is not in Sleep Mode. If all indicator lights remain off, there is no charge. Place the robot on the dock, leaving a half-inch space between the front of the robot and the face of the dock. When the robot is docked correctly and begins to charge, it will beep and the charge indicator lights will cycle.

CLEAN (RED) + ! flashing together

Suction motor failure. Remove blockages and clean filters. Remove dust bin and make sure nothing is blocking suction.

CLEAN (RED) flashing

Robot may be stuck on an obstacle. Move robot to a new location on a level surface.

MAX flashing

Robot may be stuck on an obstacle. Move robot to a new location on a level surface.

Front bumper may be jammed. Check bumper.

DOCK flashing

Your robot's BotBoundary® sensors are reporting an error. Please contact Customer Service at 1-800-798-7398.

CLEAN (RED) + DOCK flashing together

Cliff sensors are reporting an error.

Wipe cliff sensors with a clean cloth.

Robot cannot start due to an error. Turn off the power switch on the side of the robot, wait five seconds, then turn power back on. Ensure your robot is on a level surface with no obstructions.

CLEAN (RED) + MAX flashing together

The dust bin has been removed and needs to be reinserted.

MAX + ! flashing together

A side brush is stuck. Remove debris from side brushes.

CLEAN (RED) + MAX + ! flashing together

A drive wheel is stuck. Remove debris from wheel.

DOCK + MAX + ! flashing together

Blockage in brushroll. Remove obstruction.

DOCK + ! flashing together

Make sure you are using the dock that came with your robot.

CLEAN (BLUE) + MAX + ! flashing together

The robot is caught in a tight space or on an obstacle.

There is something stuck in the robot's front bumper.

Clean any obstructions or debris from the bumper. Gently push the bumper up and down and back and forth, making sure it moves smoothly.

CLEAN + DOCK + MAX + ! flashing together

The robot's wheels might be stuck, or something might be caught in them.

Check the wheels for obstructions and remove anything that might be stuck or wrapped around the wheels.

Press down on the wheels, then let them spring back into place.

Rotate wheels back and forth.

CLEAN + DOCK + MAX flashing together

Robot is in Find My Robot mode. You can deactivate this mode in the app.

Warning

This content is compiled from multiple sources and is provided for reference purposes only. It may not be complete or fully applicable to all situations. If you are unable to resolve your issue, please contact the product manufacturer or an authorized service provider for official support.