

## Getting Started

### Parts

Picture shows a double oven. Your appliance may vary slightly.

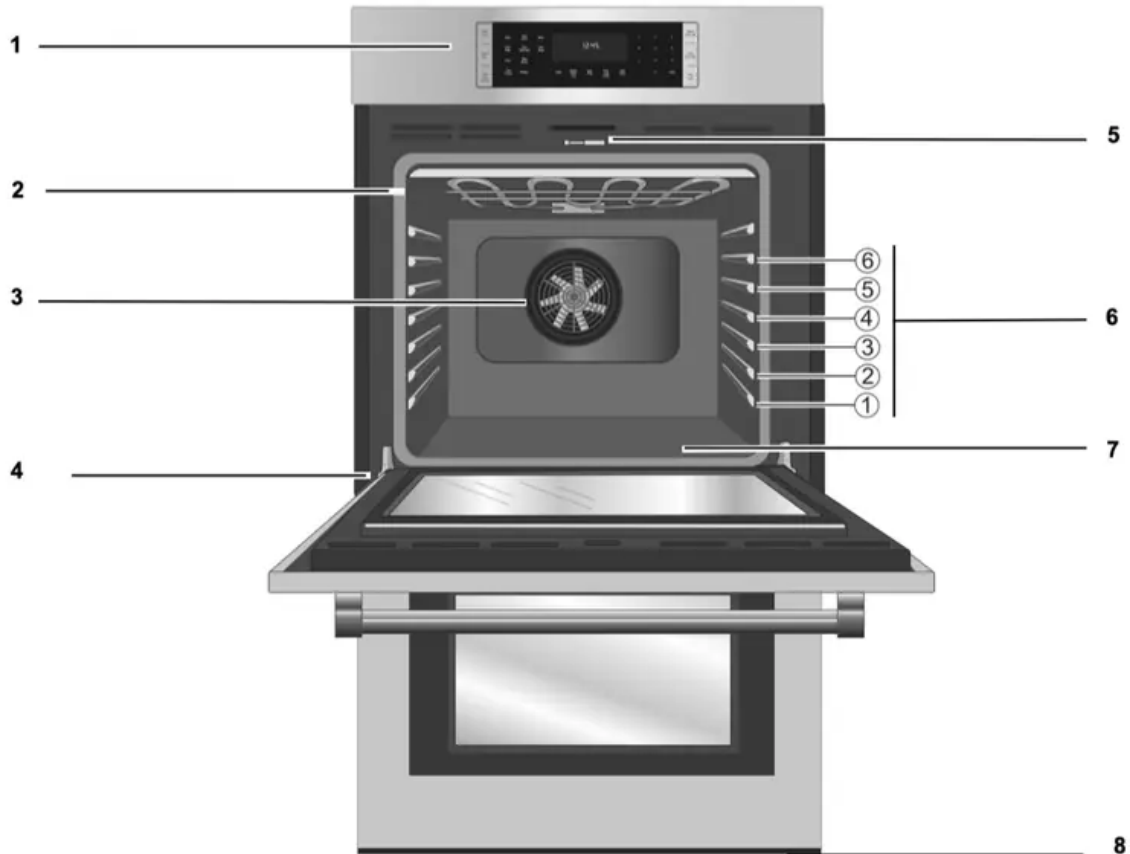

1. Control Panel
2. Door Gasket
3. Convection Fan
4. Door Hinge
5. Door Latch
6. Rack Position Guides with 6 rack positions
7. Oven Bottom
8. Oven Bottom Vent

### Cooling Fan

The cooling fan runs during all cooking modes. The fan can be heard when it is running, and warm air may be felt as it is released from the oven vent. The fan may also run after the oven is off.

**Oven Vent**

The oven vent is located at the bottom of the unit. Warm air may be released from the vent before, during and after cooking. It is normal to see steam escaping from the vent, and condensation may collect in this area. This area may be warm when the oven is in use. Do not block the vent, since it is important for air circulation.

**Oven Bottom**

The oven bottom conceals the lower heating element. As a result the element is protected from damage and spills.

**Note:**

Do not place food directly on the oven bottom.

**CAUTION**

Do not use aluminum foil or protective liners to line any part of the appliance, especially the oven bottom. Installation of these liners may result in a risk of electric shock or fire.

## Accessories

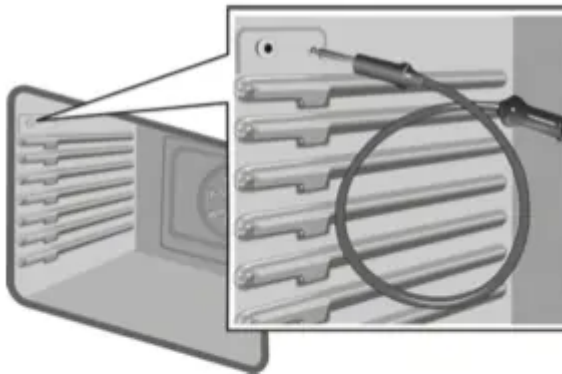

### **Probe**

The probe can be used to determine the internal doneness or the end temperature of many foods, especially meats and poultry.

Do not clean in the Self Clean oven or dishwasher.

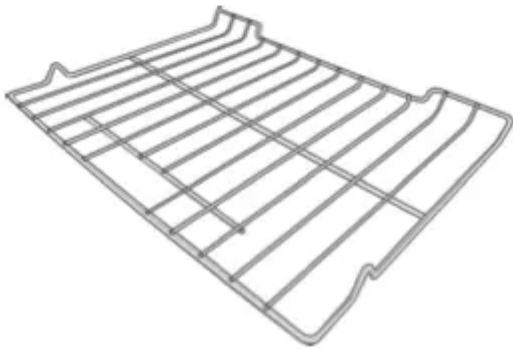

### **Flat Rack**

Use for most cooking. Can use multiple racks in some modes.

Do not clean in the Self Clean oven.



### **Telescopic Rack (some models)**

**additional 30-inch racks  
available from e-Shop,  
# HEZTR301**

Use with heavier dishes to make it easier to put dishes into the oven, check on while cooking and remove dishes from oven when done.

Do not clean in the Self Clean oven.



## **Broiling Pan and Grill**

Use for broiling and roasting.

Do not clean in the Self Clean oven.

### **Inserting Racks**

#### **CAUTION**

To avoid burns, place oven racks in desired positions before turning oven on. Always use oven mitts when the oven is warm. If a rack must be moved while the oven is hot, do not let oven mitts contact hot heating elements.

Use caution when removing an oven rack from the lowest rack position to avoid contact with the hot oven door.

To avoid possible injury or damage to the appliance, ensure racks are installed exactly per installation instructions and not backwards or upside down.

#### **Flat Rack**

The rack is designed with a stop so it will stop before coming completely out of the oven and not tilt.

To insert the flat rack into the oven:

**Note:** Avoid pushing the rack back forcefully, impacting the rear of the oven cavity. This can cause risk of damage to porcelain coating or to glass covers over light fixtures.

1. Grasp rack firmly on both sides.
2. Insert rack (see picture).

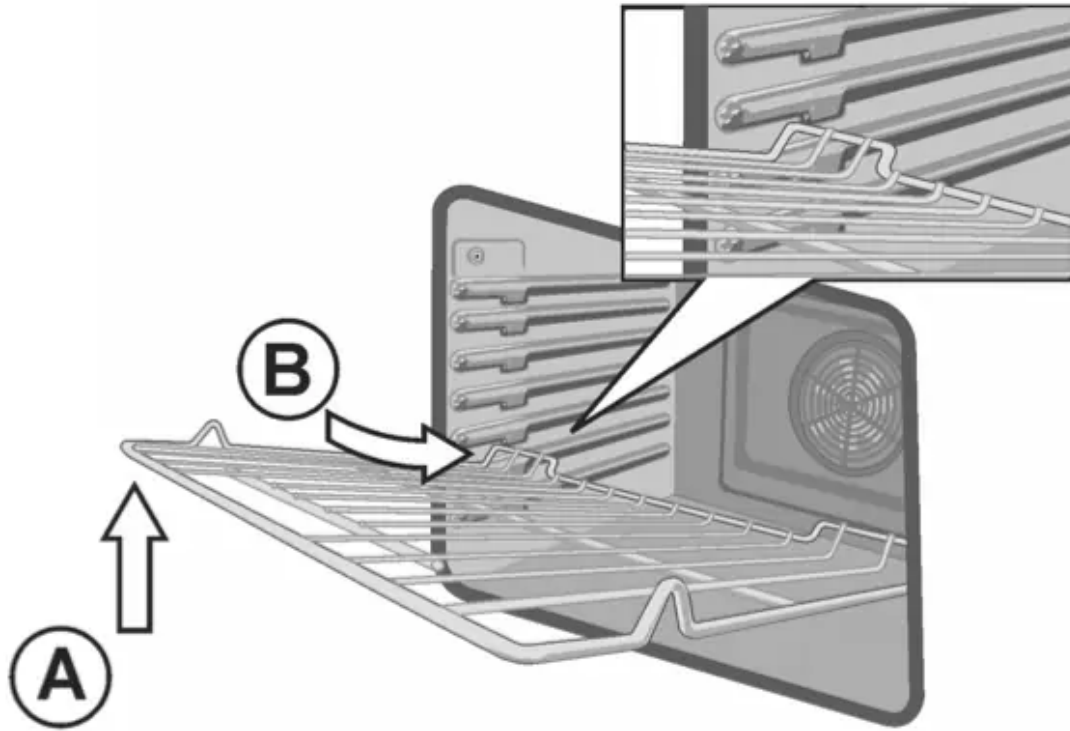

3. Tilt rack up (A) to allow the upwardly sloped rear of the rack to slide under the stop molded into the front portion of the rack guide above.

4. When the back of the rack is past this stop, lower the front of the rack to a horizontal position (B) and push it the rest of the way in.

The rack should be straight and flat, not crooked.

#### **To remove the flat rack from the oven:**

1. Grasp rack firmly on both sides and pull rack toward you.

2. When the stop is reached, tilt rack up so that the upwardly sloped back of the rack can pass under the stop. Pull the rack the rest of the way out.

#### **Telescopic Rack**

To insert the telescopic rack into the oven:

1. Slide the rack in evenly until the rear of the rack is about 2 inches from the back of the oven.

2. Tilt the front of the rack up about three-quarters of an inch (A) and finish pushing the rack all the way back (B).

**Note:** Avoid striking the oven light cover glass or the back of the oven when pushing the rack into position.

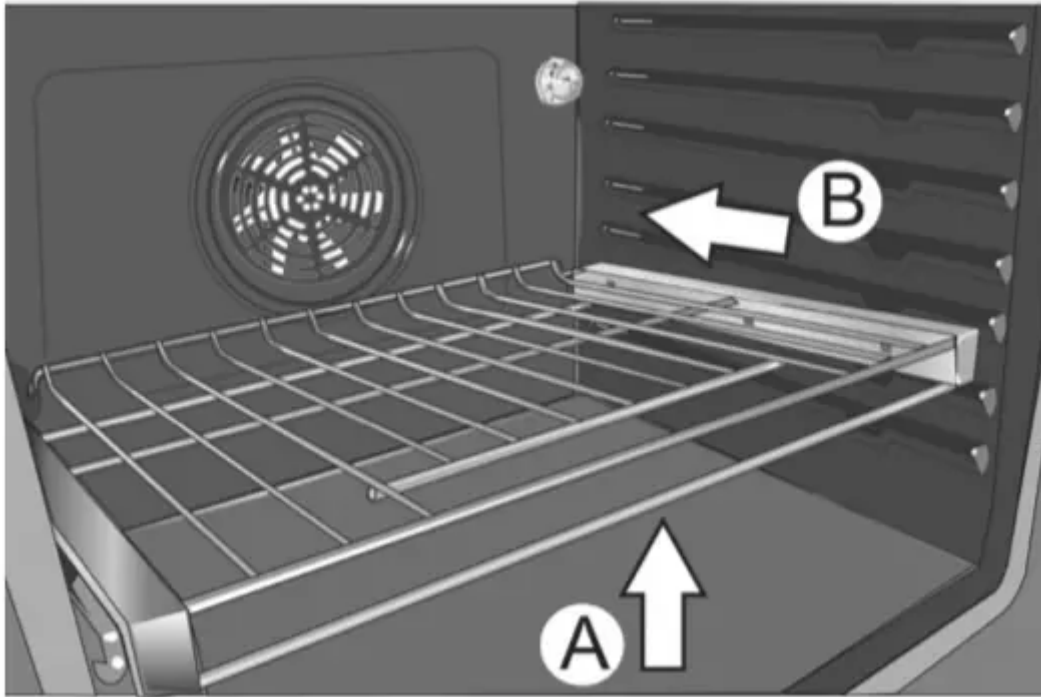

3. The back of the telescopic rack drops into place.
4. Pull the rack forward to engage the bottom of the rack onto the rear of the rack position guide.
5. Lower the front of the rack to finish seating it on the rack guide. The rack should feel stable when properly seated.
6. Slide the movable part of the telescopic rack in and out a few times to make sure it is able to move freely and that the non-moving part of the telescopic rack is securely anchored.

### **CAUTION**

To avoid possible injury or damage to the appliance, ensure the telescopic rack is installed exactly per installation instructions and not backwards or upside down.

### **To remove the telescopic rack from the oven:**

1. Lift the front of the telescopic rack assembly about 1/2 inch and push the rack to the rear about 3/4 inch. This allows the rack to disengage from the rack position guide.
2. Lift the rear of the telescopic rack assembly so it clears the rack position guide and gently pull the rack from the oven.

**Note:** Take care to avoid pulling the rack unevenly which will cause it to bind during removal, catching on the oven walls.

# Control

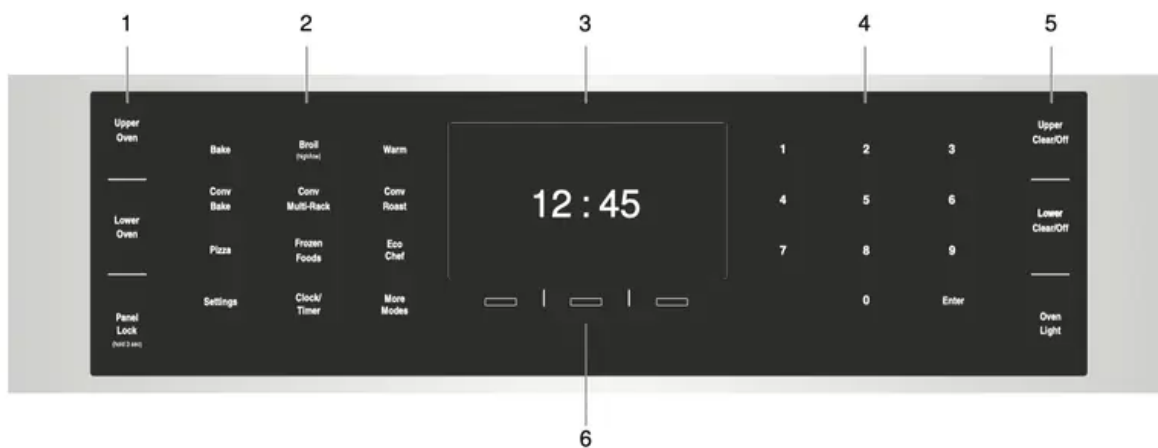

1. Left Outer buttons
2. Mode Selection buttons
3. Display
4. Numeric Keypad buttons
5. Right Outer buttons
6. Special Function buttons

## Buttons

**Note:** You only need to press lightly on the buttons to operate them. The buttons will not have any affect if you press several of them at once, such as when cleaning the control panel by wiping across it.

## Button Descriptions

	Switches to the upper oven in double oven models. Press before selecting or changing settings in the upper oven.
	Switches to the lower oven in double oven models. Press before selecting or changing settings in the lower oven.
	Turns Panel Lock mode on and off. Panel Lock prevents oven settings from being changed.
	Press to clear cooking modes, press and hold to turn upper oven off. Clears some settings.
	Press to clear cooking modes, press and hold to turn lower oven off. Clears some settings.
	Turns the oven light on and off for the selected oven.
	Updates the display to allow the clock to be set or a kitchen timer to be started or adjusted.
	Provides access to user settings to allow customization of basic display, language and other features.
	Activates Self Clean mode.
	Allows access to cooking/heating modes that do not have a direct access button.

## More Modes

Additional modes are available by pressing the More Modes button. These modes include Convection Broil, Pizza, Proof and Roast. These are discussed in the Getting the Most Out of Your Appliance section later in this manual.

Self Clean is also located in this list.

# Operation

## About the Appliance

Your new oven combines premium cooking results and simple operation.

The oven design has been optimized to improve heat distribution in the oven cavity. The result is even browning, shorter cooking times and lower energy consumption.

Thanks to the Self Clean mode, hours of scrubbing into the darkest corners of the oven is a thing of the past. The oven burns off soil simply and easily. All that is left to do is to remove a few ashes from the oven when Self Clean is done.

Clear labeling of the buttons makes operating the oven very easy. This manual includes all instructions for operating the oven.

Please call us if you ever have any questions. Our telephone number is located at the beginning of this manual. We welcome your comments and suggestions!



## **Before Using the Oven for the First Time**

- Oven must be properly installed by a qualified technician before use.
- Remove all packing materials from inside and outside the oven.
- While cool, wipe with a clean, damp cloth and dry.
- There may be a slight odor during first uses; this is normal and will disappear.
- Optimum cooking results depend on proper bakeware being used.
- Read and understand all safety precautions and Use and Care Manual information prior to operating.

## **Basic Features**

### **Using buttons and Entering Numeric Values**

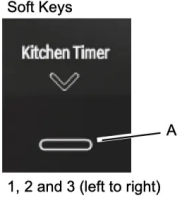
The oven interface is easy to use but requires some awareness of how entries must be made. Follow the procedures below.

Button Type	Description of Use										
Standard buttons and Numeric Keypad Digits	<p>Press the center of the button to activate it. Buttons are electrostatically sensitive and require only light pressure. If Panel Lock is activated, the buttons will not respond to touch.</p> <p><b>Note:</b> Press and hold the “Panel Lock” button (located on the left side of the display) for 3 seconds to activate/deactivate the panel lock.</p>										
 <p>1, 2 and 3 (left to right)</p>	<p>Soft keys are rounded rectangular buttons (A) below the three  symbols on the oven display.</p> <p>The function of these buttons changes for different contexts.</p> <p>To use a soft key, press the rounded rectangular button below the display, not the screen text above the  symbols. The display is not a touch screen.</p>										
<p>Entering a numeric value using the numeric buttons</p> <p><b>Example Entry:</b> 4:55 pm</p> <table border="1" data-bbox="183 1232 367 1400"> <tr> <td>Initial Time:</td> <td>04:46 pm</td> </tr> <tr> <td>Enter: 0</td> <td>44:60 pm</td> </tr> <tr> <td>Enter: 4</td> <td>46:04 pm</td> </tr> <tr> <td>Enter: 5</td> <td>60:45 pm</td> </tr> <tr> <td>Enter: 5</td> <td>04:55 pm</td> </tr> </table>	Initial Time:	04:46 pm	Enter: 0	44:60 pm	Enter: 4	46:04 pm	Enter: 5	60:45 pm	Enter: 5	04:55 pm	<p>Values are entered in four digits for time and three digits for temperature. When entering a value with fewer digits, such as a time that is less than 10 hours, and the first digit of the current value is not zero, add a leading zero. To enter 4:55 pm, enter 0,4,5,5 and select “pm”. As digits are entered they appear from the right, “pushing” the original digits to the left as each new digit is entered.</p>
Initial Time:	04:46 pm										
Enter: 0	44:60 pm										
Enter: 4	46:04 pm										
Enter: 5	60:45 pm										
Enter: 5	04:55 pm										

## Setting the Clock

The oven includes time functions that require the current time to be set. It is therefore important to set the clock before beginning to use the oven. The oven can not be in a cooking mode when setting the clock (oven must be on but with no cooking mode selected).

In the event of a power outage, “12:00” appears in the display. The correct time will need to reset.

### To set the clock:

1. The oven must be in Standby mode (oven is powered on, but no cooking mode or timer in operation).
2. To access the clock set mode:

Press the Clock/Timer button. The display shows the option to Set Clock or Set Timer. The “00:00” blinks in the display.

Press the soft key (the small horizontal white outlined rectangle) marked “Set Clock” underneath the down pointing arrow icon (▼).

**Hint:** Pressing the “Set Clock ▼” area of the display will have no effect. Press the small horizontal white outlined rectangle below the prompt.

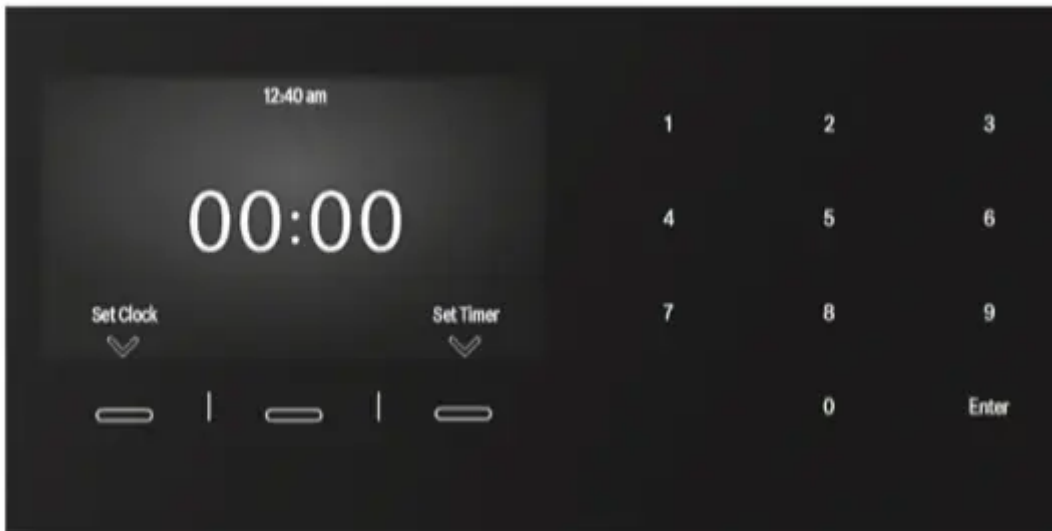

3. The left and right soft keys allow the user to adjust 1 hour +/- (such as for Daylight Savings Time). Press the center button “Manual Change” to allow the numeric keypad to be used to enter a specific time and to select am or pm.

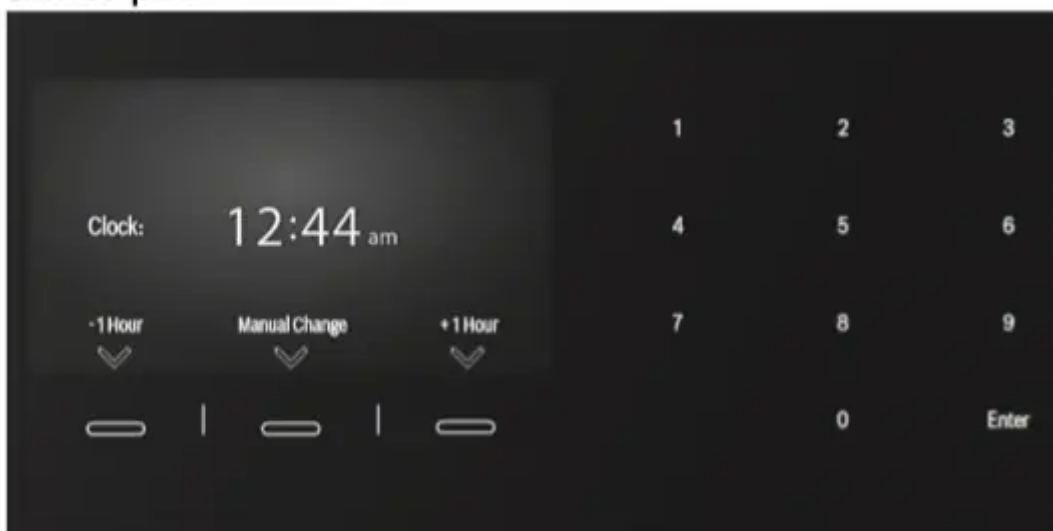

4. The display shows the reassignment of the soft keys. The left and right buttons show “am” and “pm”. Use the numeric keypad to enter the time in hh:mm, starting with a leading “0” if the hour is less than 10. Note the digits fill from the right, “pushing” the original digits off to the left as new digits are entered. Press the button for “am” or “pm” to complete the time entry and return to the normal operating clock display.

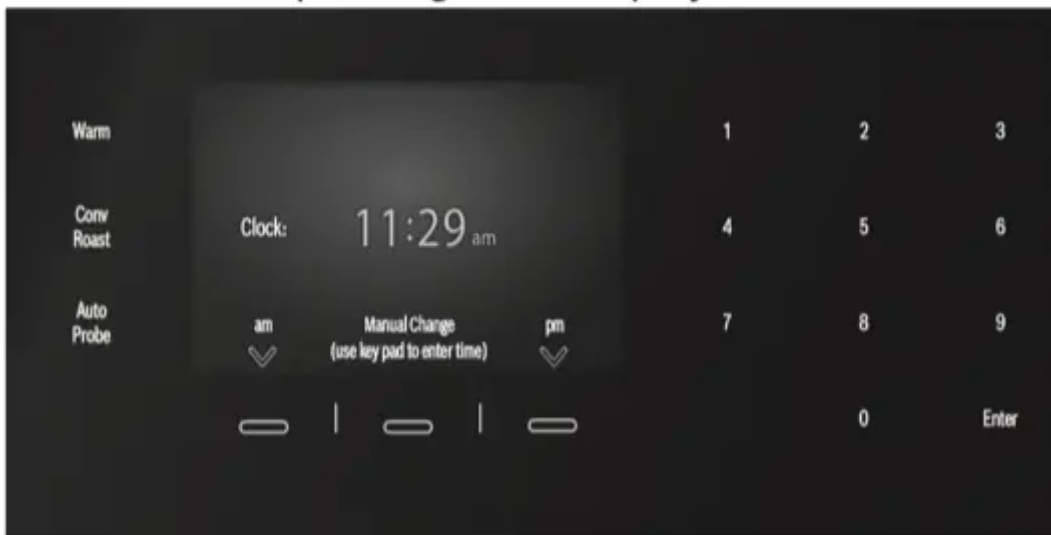

For example, to enter 3:25 pm, press the numeric keypad digits 0,3,2,5 and press the “pm” button. The display returns to the normal clock display.

**Hint:** If the am/pm setting is already shown correctly, pressing Enter on the numeric button will also save the clock setting and return to the clock display.

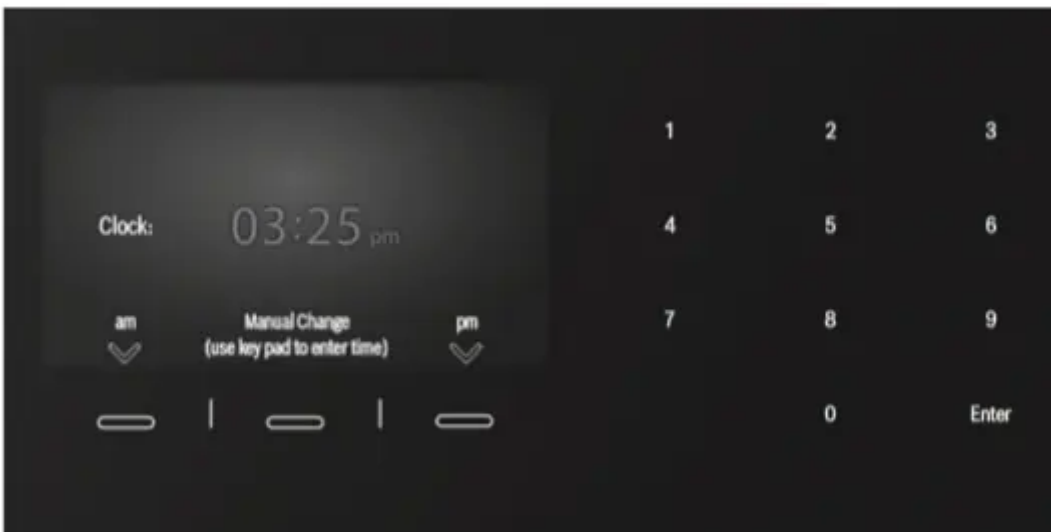

5. The clock is now set and running.

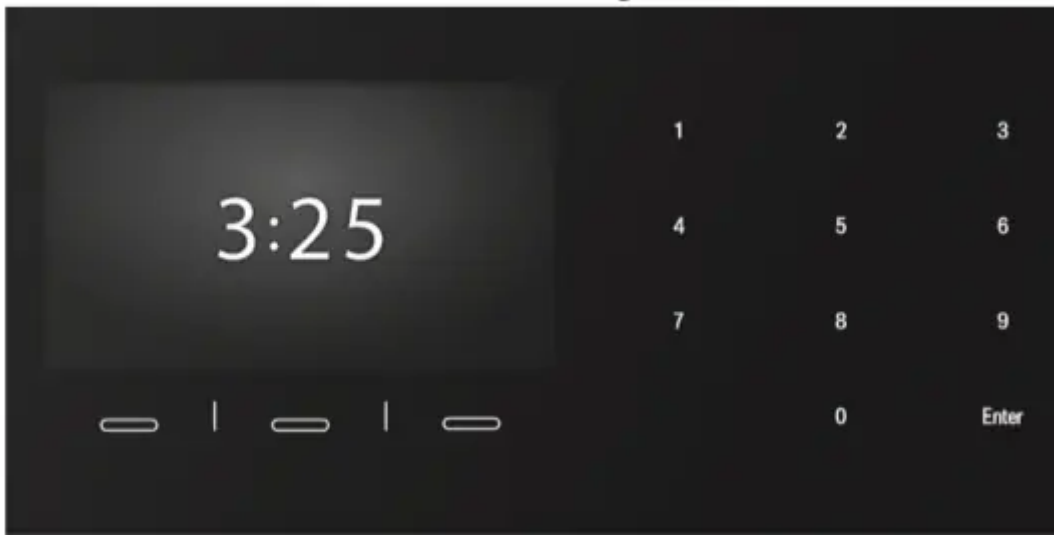

### Setting the Cooking Mode and Temperature

1. For double oven models, the particular oven must be selected before the cooking mode can be selected. Press the Upper Oven or Lower Oven button to select an oven.
2. Press the desired Cooking Mode button. For example, press the “Bake” button. The cooking mode and default temperature are displayed. The temperature blinks to show it can be edited.

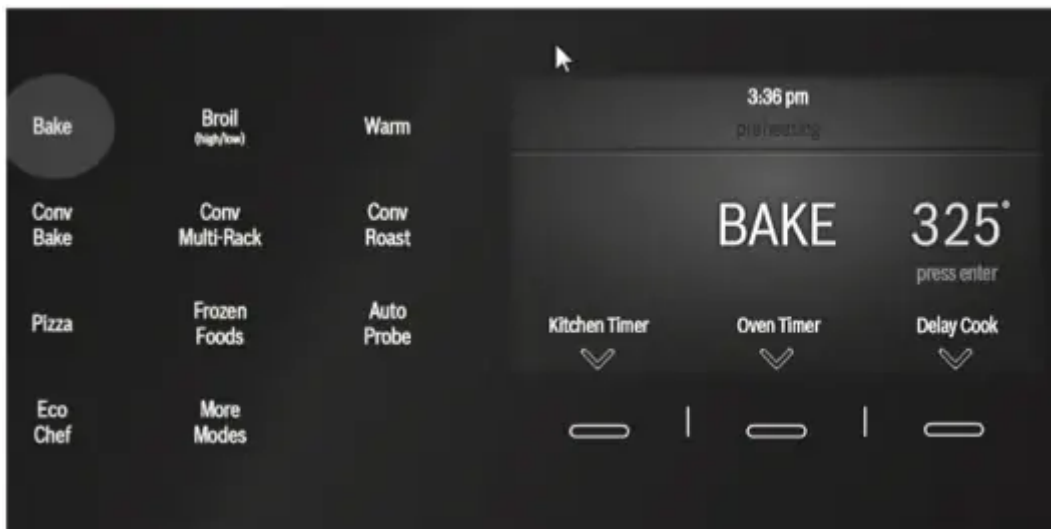

3. Press Enter to start the mode using the default temperature. For modes that require preheating, the preheat indicator progresses until the target temperature is reached.



**Note:** If a temperature is entered that is not within the allowed range for the mode an error tone will sound and the acceptable temperature range for the mode will display below the temperature entered.

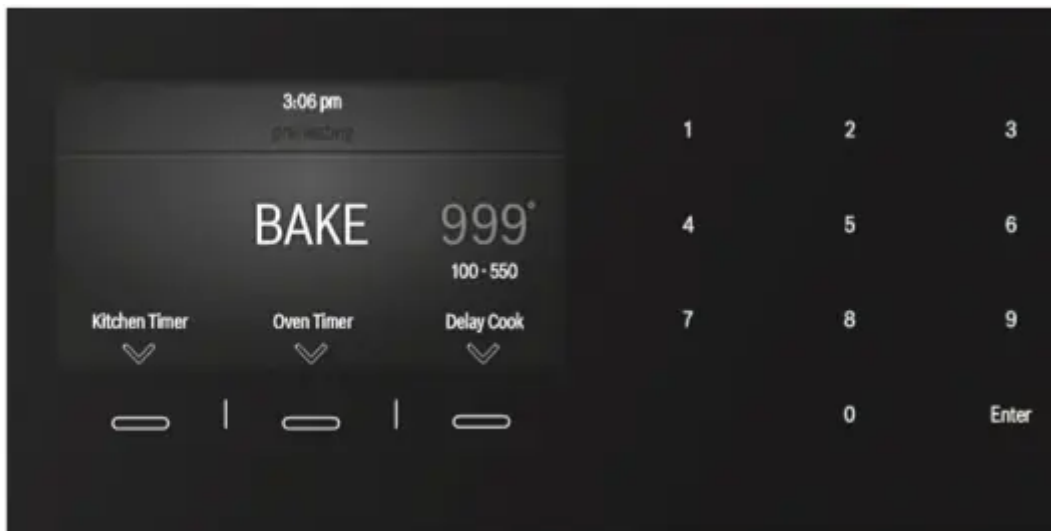

Using the numeric keypad, enter a temperature within the acceptable temperature range. Press Enter to start the mode using the temperature entered.

### Heating Time Limitation

The maximum heating time is limited. If you forget to turn off the oven, it turns off automatically after a set period of time (see table below), unless using Oven Timer or Delay Cook.

The maximum time for Sabbath Mode is 74 hours. For all other cooking modes the maximum allowed time depends on the temperature:

Temperature in °F	Temperature in °C	Max. time allowed without activity
100–200	30–120	24 hours
201–550	121–300	12 hours

Heating stops until a setting is changed.

## Timers

Your new oven is equipped with two types of timers.

**Kitchen Timer** - is a countdown timer that has no affect on oven heating. The kitchen timer is used for general kitchen timing needs.

**Oven Timer** - is a countdown timer which upon reaching 00:00 turns the oven off, stopping the current mode. The oven timer is used to set how long a mode will run.

To access either type of timer, first select a cooking mode using one of the mode selection buttons.

### To set a kitchen timer:

(without a cooking mode)

This is for general kitchen timing needs that do not need to affect oven operation.

For double ovens, first select the Upper or Lower oven. This does not have any affect on the oven stop time. It assigns a position for the kitchen timer in memory so a second kitchen timer can later be started if desired.

1. Select a cooking mode and adjust temperature as desired. Begin cooking mode by pressing Enter. The soft keys at the bottom of the display show Kitchen Timer, Oven Timer and Delay Cook. Select Kitchen Timer.

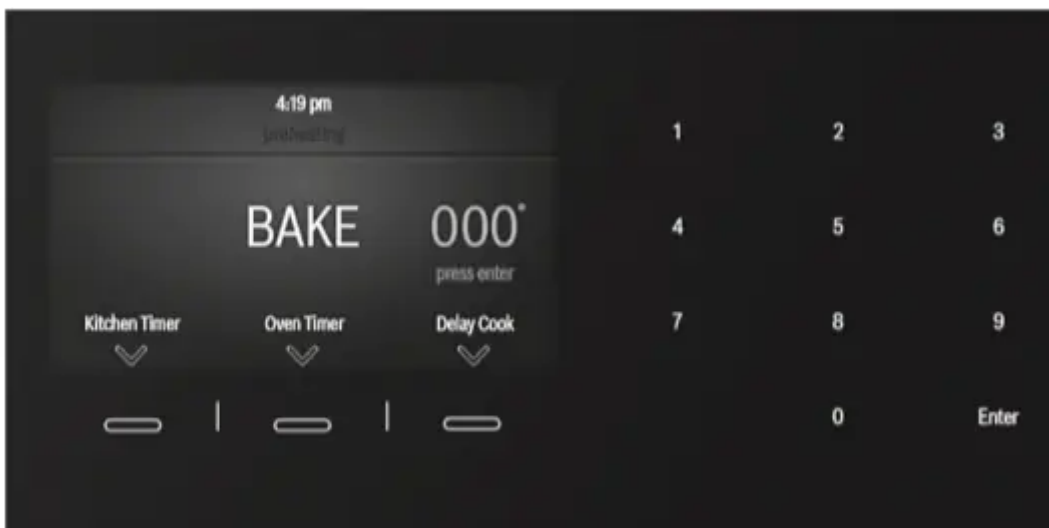

2. "00:00" is displayed blinking to the left of the mode name. Use the numeric keypad to replace "00:00" with the desired timer value.



3. Press Enter to save the timer setting. The kitchen timer starts.

4. When the kitchen timer has counted down to zero an alarm tone sounds every 10 seconds for 2 minutes.

Cancel the kitchen timer - by pressing the Oven Clear/Off button or by opening the oven door.

The kitchen timer can also be set by pressing the Clock/Timer button at the left of the control panel. The timer input "00:00" value blinks in the center of the display. Enter the desired timer value with the numeric buttons and press Enter to start the timer.

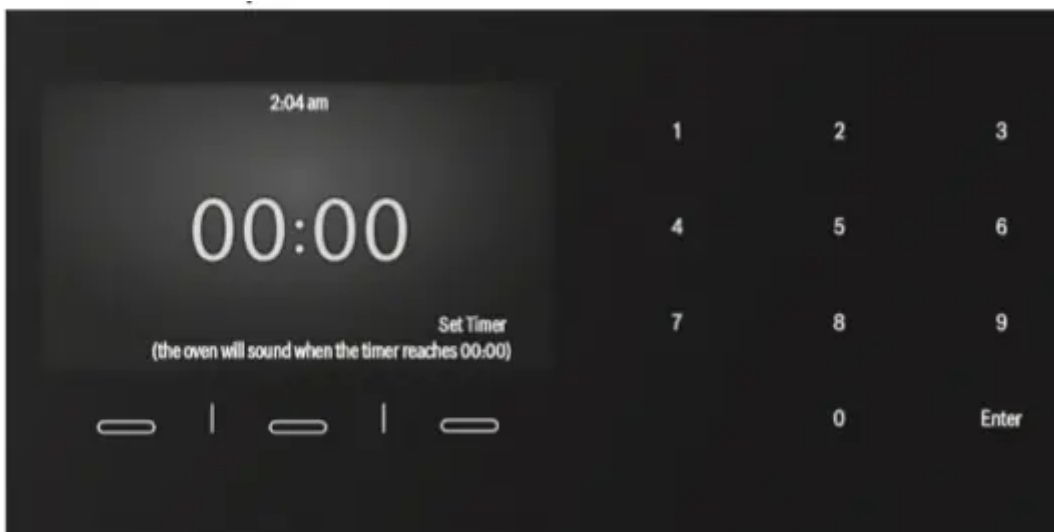

### Note

- The timer does not change when other settings are changed.
- The indicator on the display depends on what is set in the Settings. The standard display setting shows the clock while the timer is running. In this case, press Timer to view the running timer.

### To set an oven timer:

(for setting a timer to turn the oven off)

1. For double ovens, first select the Upper or Lower oven. The oven must be running a cooking mode in order to set an oven timer.

**Note:** An oven timer can not run during Self Clean.

2. Select a cooking mode. The soft keys at the bottom of the display show Kitchen Timer and Oven Timer. Select Oven Timer.

3. "00:00" is displayed blinking to the left of the mode name. Use the numeric keypad to replace "00:00" with the desired timer value.

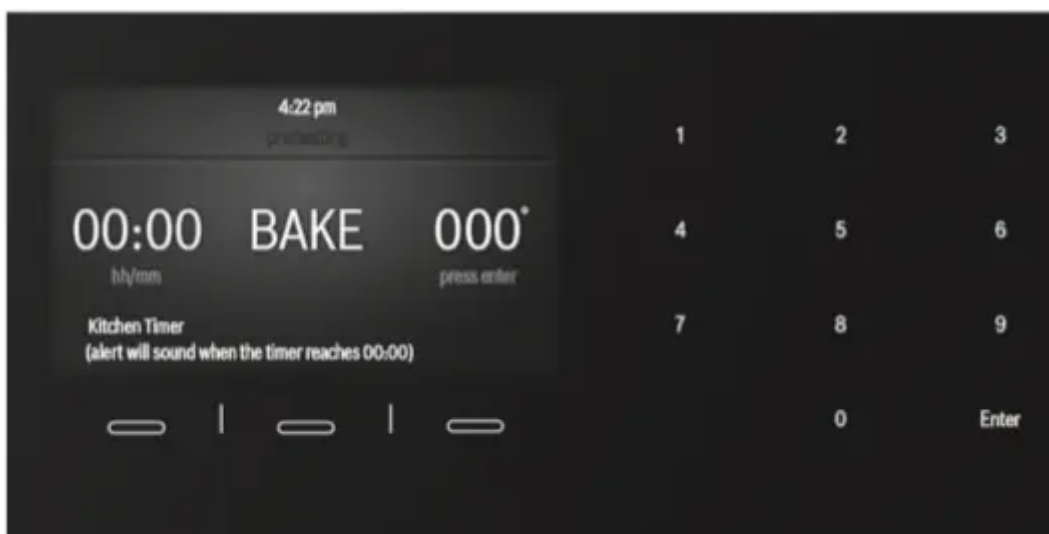

4. Press Enter to save the oven timer setting.

The oven timer starts. The oven timer counts down to 0:00.

5. When the timer reaches :00 the cooking mode ends. The oven alarm tone sounds every 10 seconds for 2 minutes.

### Fast Preheat

Fast Preheat heats the oven quicker than standard preheat. It is available for Bake, Roast, Convection Multi Rack, Convection Bake, Convection Roast, and Pizza. If Fast Preheat is not allowed for the selected cooking mode an error tone sounds. Fast Preheat is not available for Broil, Convection Broil, Proof or Warm.

### To set Fast Preheat:

1. For double ovens, first select the Upper or Lower oven. Set the cooking mode (from the modes for which Fast Preheat is available) and temperature.

2. Press Fast Preheat.

3. Press Start. Fast Preheat can be turned off by pressing Fast Preheat again.

**Note:**

- The temperature must be set to at least 200° F (100° C) to use Fast Preheat.
- Fast Preheat remains on even if the cooking mode is changed after Fast Preheat is started. If Fast Preheat is not available for the new mode, Standard preheat is activated for models that have Standard preheat.

## Special Features

The special features provide you with additional conveniences when cooking.

Learn more about these special features in the following sections:

- Delay Cook
- Auto Probe
- Sabbath Mode
- Panel Lock

### Delay Cook

The Delay Cook (End Time) feature allows the oven to be programmed to finish a timed cooking mode at a predetermined time.

#### CAUTION

To maintain food safety, do not leave food in the oven for more than one hour before or after cooking.

The Delay Cook timer can only be set from Standby mode or while a cooking mode is running.

#### To set the Delay Cook Time:

1. For double ovens, first select the Upper or Lower oven.
2. Set the cooking mode and temperature. Press Enter to start the mode.
3. Press the context sensitive Delay Cook button. The Set Delay Cook Time screen is displayed.



4. Enter the start time and the end time. Press Enter to begin Delay Cook.

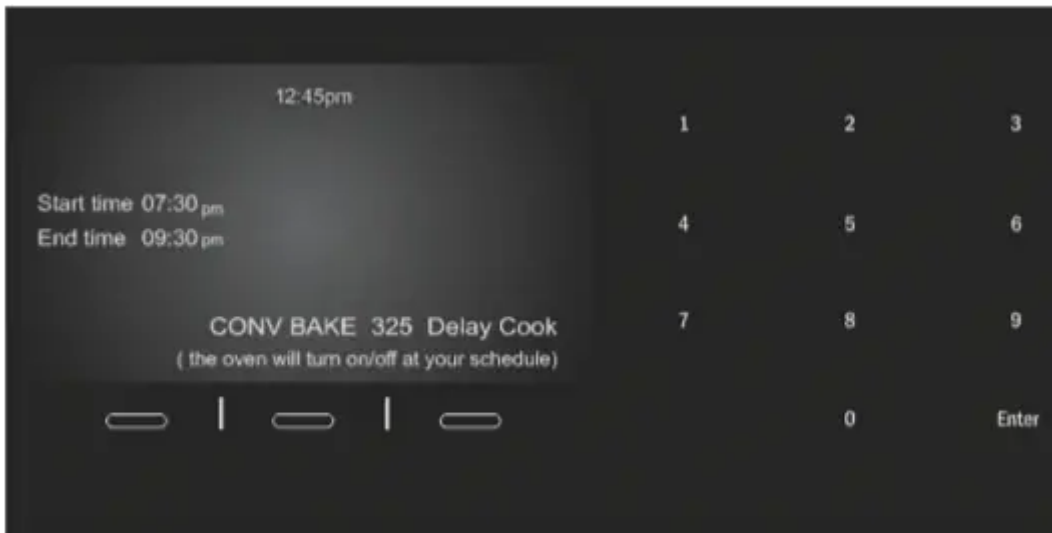

5. If the start time set is later than the current time, the display shows the current time with the Delay Cook notification and the start time, mode and temperature.



6. When the Delay Cook timer starts the mode the timer time remaining, mode and temperature are shown in the center of the display.



At this point, Delay Cook acts exactly like an oven timer. At the end of the timer countdown, the oven will sound a signal and the mode will end. Press Timer Off or open oven door to silence the alarm.

**Note:**

- To cancel Delay Cook, press the Oven Clear/Off button (for double ovens, first select the upper or lower oven).

**Auto Probe**

The probe measures the internal temperature of the food. The probe is available for Bake, Roast and all convection cooking modes except Convection Broil.

**Remove Safety Cap before Using Probe**

Some models include a temperature probe used to sense internal temperature of meats during cooking.

The probe ships with a black plastic safety cap over the pointed metal end of the probe. The cap must be removed prior to use.





### **Inserting the probe:**

Insert the tip of the probe in the middle and thickest part of the meat or the breast for poultry. Make sure the probe is not touching fat, bone, or parts of the oven or the pan.

**Note:** Food must be completely thawed before inserting the probe into the meat.

### **To use the probe:**

1. Insert the probe into the meat as described above.
2. Connect the probe to the oven. If the probe is not connected to the oven prior to starting Probe mode, an error tone sounds.
3. Press the Auto Probe button. The Set Probe and OvenTemp screen is displayed. Use the soft keys at the bottom of the display to select screens to enter the desired food temperature, the oven mode to use and the oven temperature. Use the numeric keypad to enter the desired values. Press Enter on the numeric keypad to confirm the settings and to start the probe mode.
4. Set the cooking mode and temperature..

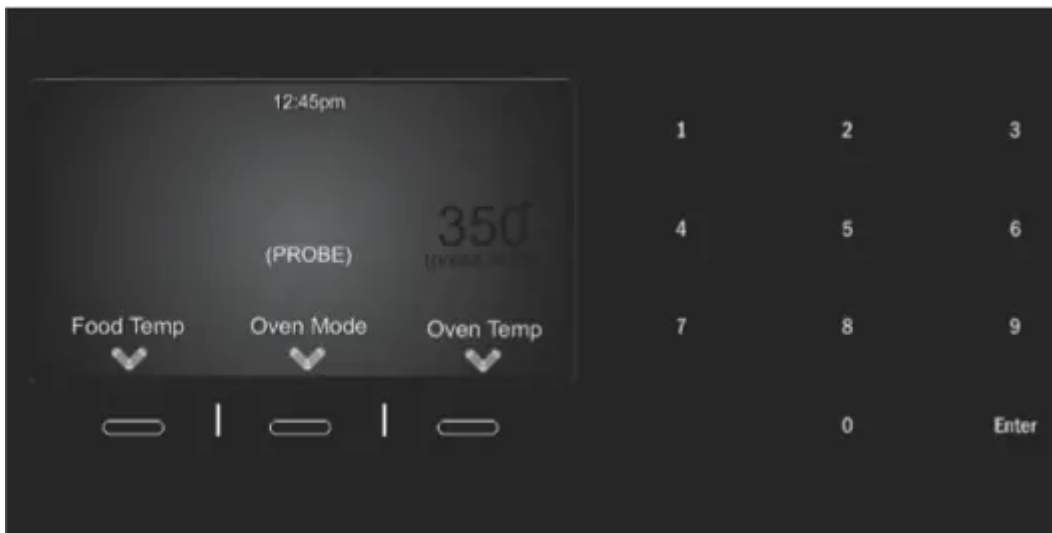

**Note:** The minimum probe temperature that can be set is 100° F (40° C) and the maximum is 200° F (100° C). If the probe temperature entered is outside this range, an error is displayed.

The displayed probe temperature is updated in increments of 5° during the cooking process.



When the probe temperature reaches the set temperature, the cooking mode turns off. The current time is displayed. An alarm tone sounds every 10 seconds for 2 minutes.

This screen remains in the display until it is cleared by pressing the Oven Clear/Off button or until the probe is removed. The display then goes back to standby mode.

The probe is only available for the upper oven in double oven units.

**Note:**

- Probe is not available when an Oven Timer has been set.
- To change the probe temperature press the Probe button. The display enters probe temperature editing mode and displays the message “SET PROBE TEMP”. Enter the new probe temperature and press Enter to accept the new value.
- Do not store the probe in the oven.



- Always use the handle of the probe for inserting and removing.
- Always use a potholder to remove the probe since it becomes hot.
- The probe is only available for the upper oven in double oven units.

## **Sabbath Mode**

The Sabbath Mode enables those of particular faiths to use their ovens on the Sabbath. Sabbath Mode must be activated in the Settings menu (the default setting for Sabbath Mode is “Yes”).

The Sabbath Mode can be entered in a bake cycle only

The bake temperature must be within the Sabbath Mode temperature range of 100° to 450° F. Once the Sabbath Mode has been started the cooking temperature can be changed (within the Sabbath Mode allowable temperature range) by using the numeric keypad and pressing Enter to confirm the new temperature. There is no visual or audible response to input and there is a 30 second delay before the new temperature is activated.

If the oven light is on during setup, it remains on throughout the Sabbath Mode operation. If the oven light is off during setup, it remains off throughout the Sabbath Mode operation.

### **To set the Sabbath Mode:**

1. No kitchen timers or oven timers may be running when Sabbath Mode is entered. The probe must not be inserted.

The Bake mode must be running (or in the process of being set up to run). Press the Oven Timer soft key for five seconds.

If a timer is running or the probe is inserted or the temperature set is outside the acceptable Sabbath Mode range when Sabbath Mode attempts to start, the display blinks the message: “SABBATH NOT AVAILABLE” for 5 seconds.

If no timers are running, the Sabbath Mode display is shown. The oven temperature (in red) blinks to indicate it can be changed. Use the numeric buttons to enter a new temperature if desired. The acceptable range for Sabbath Mode temperatures is 100° to 450° F.



2. Enter the duration (amount of time that Sabbath Mode is to run), shown on the display blinking in red, indicating it can be changed. The start time is set to 6:00 pm. The start time for Sabbath Mode can be delayed using the Bake mode soft key "Delay Cook".



3. When the start time is reached Sabbath Mode begins, the display shows the oven preheating in Sabbath Mode.





**Note:**

- Double ovens are capable of running Sabbath Mode on both the upper and the lower oven, individually or both at the same time.
- The temperature in Sabbath Mode is 100° to 450° F.
- The Sabbath Mode timer can be set between 0:01 and 74 hours.
- A "Holiday Cook Time" option can be added to the Sabbath cooking instructions by pressing the edit Holiday soft key and entering the desired Holiday information as prompted.

**Panel Lock**

Allows the user to disable all buttons on the control panel. Panel Lock can only be enabled in standby mode (oven is turned on, but no cooking mode or oven timer is running).

1. To enable Panel Lock, press and hold the Panel Lock button for 3 seconds (in standby mode).
2. To disable Panel Lock, press and hold the Panel Lock button for 3 seconds. The display returns to standby mode.

**Settings**

The Settings menu is used to customize certain oven settings.

The oven must be in Standby mode (no cooking mode or oven timer running) in order to access the Settings menu.

**To make changes to Settings Menu Items:**

1. Press the Settings button.
2. The list of Settings items is displayed. Scroll through the list using the center soft key. Each Settings item is highlighted as it is selected.





3. To edit a Settings item, when it is highlighted, press the left hand soft key labeled “enter”. For a description of each item see the table following.

4. To change the value for the displayed setting press the rightmost soft key to scroll through the list. With the desired setting highlighted, press the Enter button on the numeric keypad.

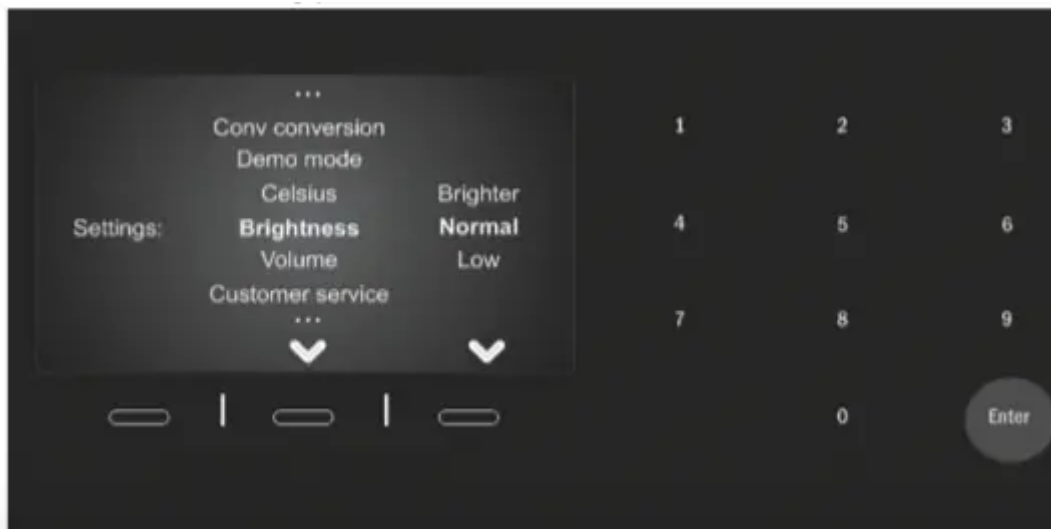

The new value is automatically accepted as the display reverts from edit back to display mode.

**To exit the Settings menu:**

Press the Clear/Off button.

**Oven Temperature Offset**

The oven is calibrated to provide accurate results. This feature is useful if you prefer your foods lighter or darker. When an offset temperature is selected, the actual oven temperature is raised or lowered by this value.

The oven must be turned off in order to set an offset value. Refer to “Temperature Offset” in “Settings Menu Options” for setting.



## Settings Menu Options



	<b>Menu Item</b>	<b>Description</b>	<b>Default</b>
1	Temperature Units	Fahrenheit (°F) or Celsius (°C)	°F
2	Brightness	High, Medium, Low	High
3	Volume	High, Medium, Low, Off	High
4	Clock mode	12-hour or 24-hour display mode. 12HR, 24HR.	12HR
5	Auto Convection Conversion	Decreases oven temperature by 25° F set for Convection Bake and Convection Multi-Rack cooking modes. ON, OFF.	OFF
6	Standby Clock Display	Clock displays when no cooking mode or timer is in use. ON, OFF.	ON
7	Language	Language setting: EN (English), FR (French)	EN
8	Temperature Offset	Sets the temperature offset value for Convection Bake, Convection Roast and Convection Multi-Rack. When an offset value is entered, the actual oven temperature is increased or decreased by this value. This feature is useful if food is consistently either too brown or too light. The range for changing the offset is between +/- 35° F (+/- 19 °C) in 1° increments. For double ovens: You can set the Oven Temperature	0

9	Customer Service	Shows customer service contact information.	n/a
10	Demo Mode	Cycles through six screen images at timed intervals. The interface works, but does not operate the oven modes. To exit Demo Mode, access settings and turn Demo Mode to Off. Demo mode stays on otherwise, including through power outage. "On", "Off"	Off

## Getting the Most Out of Your Appliance

### General Tips

#### Pan Placement

Baking results are better if pans are placed in the center of the oven. If baking more than one pan on a rack, allow at least 1" to 1 ½" of air space around the pan. When baking four cake layers at the same time, stagger pans on two racks so that one pan is not directly above the other.

#### Rack Position

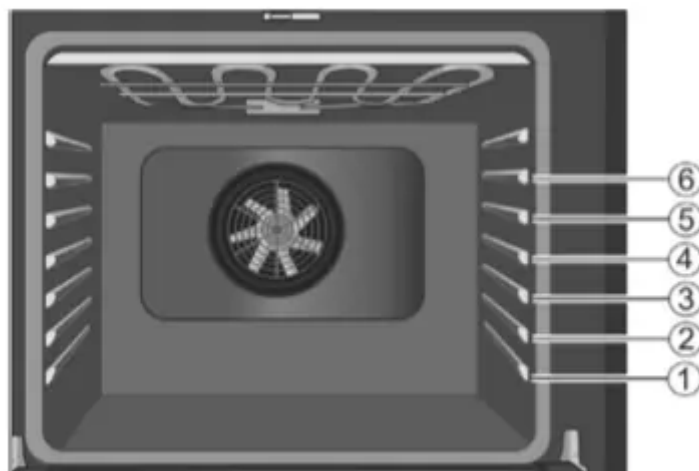

Rack positions are numbered from 1 to 6, from bottom to top.

Consult the food cooking charts at the back of this manual for recommended rack positions.

The top rack guide is not used with the cooking racks. Use rack positions 1 through 6 only. The top guide is there only to bracket the rack and prevent it from tipping when inserted in position 6. Inserting a rack onto the top guide would not be stable, since there is no guide above it to prevent tipping. DO NOT attempt to use the top guide to support a rack.

<b>Rack Position</b>	<b>Best For</b>
<b>6 (highest usable position)</b>	<b>hamburgers, steaks</b>
<b>5</b>	<b>toasting bread, broiling most meats, melting cheese</b>
<b>4</b>	<b>thicker meats</b>
<b>3</b>	<b>broiling poultry, most baked goods on a cookie sheet or baking pan using a single rack, includes frozen convenience foods, cakes, casseroles, frozen pizza</b>
<b>2</b>	<b>small roasts or poultry, bundt cakes, pies, breads</b>
<b>1 (lowest position)</b>	<b>large roasts, turkey, angel food cake</b>

### **Aluminum Foil**

Do not use aluminum foil or protective liners to line any part of the appliance, especially the oven bottom. Installing these liners may result in risk of electric shock or fire.

### **Preheating the Oven**

- Place oven racks in desired position before heating the oven.
- Preheat the oven when using the Bake, Convection Bake, Convection Multi Rack, Pizza, Broil, Convection Broil, and Warm modes.
- Preheat is not used for Roast, Convection Roast and Proof modes.
- Allow oven to preheat while preparing recipe ingredients or food items.
- Setting a higher temperature does not shorten preheat time.
- Once oven is preheated, place food in the oven as quickly as possible to minimize the loss of heat and reduction of oven temperature.
- Use Fast Preheat to speed up preheating.

## Preheat Reminders

Your oven has one of the fastest preheat times in the market using a concealed bake element. The lower element is hidden under the oven bottom. It is normal that the preheat time is different than your previous oven that had an exposed element on the bottom.

- Cleaning the oven is easier because there is no cleaning around a coil element showing on the bottom of the oven. The hidden lower element is protected from food soils and spills. Wiping up excess spills is easy.
- Preheating is not necessary for meats, poultry, casseroles and frozen foods.
- Preheat time will be longer when the electrical supply to your house is less than 240 volts.
- Increasing the oven temperature will require a longer preheat time. For example, the preheat time for 425° F is longer than the preheat time for 350° F.

When broiling, preheat the oven 3-4 minutes. Do not preheat for more than 5 minutes.

## For Best Results

- Use the cooking recommendations as a guide.
- Open the door as briefly as possible to avoid temperature reduction.
- Use the interior oven light to view the food through the oven window rather than opening the door frequently.
- Use the Kitchen Timer to keep track of cooking times.

## Baking Pans and Dishes

- Glass baking dishes absorb heat. Reduce oven temperature 25° F when baking using glass dishes.
- Preheat the oven before adding glass baking dishes.
- Use pans that provide the desired browning. For tender, light, golden-brown crusts, use light, anodized or shiny metal bakeware.
- Dark, rough or dull pans (nonstick or anodized) will absorb heat and result in a browner, crisper crust. Some manufacturers recommend reducing the temperature 25° F when using this type of pan. Follow manufacturers' recommendations.
- Insulated cookie sheets or bakeware will increase the length of cooking time.
- Do not set any heavy object on the open oven door.
- Do not keep empty pans or pizza stones in the oven during cooking as this could change the cooking performance. Store pans outside the oven.

## High Altitude Baking

- When cooking at high altitudes, recipes and cooking times will vary.

- For accurate information, write the Extension Service, Colorado State University, Fort Collins, Colorado 80521. There may be a cost for the guides. Specify which high altitude food preparation guide you prefer: general information, cakes, cookies, breads, etc.

### Condensation

- It is normal for a certain amount of moisture to evaporate from the food during any cooking process. The amount depends on the moisture content of the food. The moisture may condense on any surface cooler than the inside of the oven, such as the control panel.

### Temperature Range (°F) by Cooking Mode

Mode	Lowest	Highest
Bake	100	550
Roast	100	550
Broil (Low, High)	450	550
Warm	150	225
Proof	85	125
Convection Bake	100	550
Convection Multi-Rack	100	550
Convection Roast	100	550
Pizza	100	550
Convection Broil (Low,High)	450	550
Frozen Foods	100	550
EcoChef	100	550

## Cleaning and Maintenance

### Cleaning

#### Self Clean

#### WARNING

Children should not be left alone or unattended in an area where appliances are in use. During the Self Clean cycle, parts of the appliance may become potentially harmful to persons who lack adult knowledge of appliances and adult reactions to potentially harmful conditions.

During the elimination of soil during self-cleaning, small amounts of carbon monoxide can be created. Fiberglass insulation could give off very small amounts of formaldehyde during the first several cleansing cycles. To minimize exposure to these substances, provide good ventilation with an open window, or use a ventilation fan or hood.

During Self Clean, the oven is heated to a very high temperature. Soil is burned off at this temperature.

**NOTICE:**

- Wipe out excessive spillage before self-cleaning the oven.
- Do not clean parts or accessories in the Self Clean oven. Remove all baking dishes and oven racks from the oven prior to running Self Clean.

**To set the Self Clean mode:**

1. Remove all accessories and racks from the oven.
2. Select the oven to be Self Cleaned (for double ovens). If there is a cooking mode on for the selected oven, press Oven Clear/Off to end the running mode.
3. Press the More Modes button. Self Clean appears in the display. The Self Clean timer default (3:00) hours blinks to indicate it can be accepted or changed.

To accept the (3:00) hour default Self Clean time, press Enter on the numeric keypad.

To enter a different number of hours or to schedule a delayed start Self Clean, press the appropriate soft key and follow prompts. Self Clean can be run for 2, 3 or 4 hours. Entering a value less than 2:00 or greater than 4:00 results in an error tone and message.

Use a longer setting for a heavily soiled oven.

4. When the desired Self Clean time is displayed press Enter on the numeric keypad.

**The oven door locks prior to starting Self Clean.**

The door lock symbol  is displayed and blinks while the door is being locked. Once locked, the door lock symbol is continuously illuminated (not blinking).

The door lock symbol remains illuminated as long as the Self Clean mode is running.

**Note:** The door remains locked until the oven has cooled down after self-cleaning. The door can be opened again only after “Finished” appears on the display.

5. When door is securely locked, the Self Clean process begins and the oven Self Clean timer begins its countdown.

**To Cancel Self Clean**



Press the Oven Clear/Off button to cancel Self Clean. When the Self Clean timer ends, for safety the unit must cool down before the door can unlock. During this period the message “COOLING DOWN” is displayed.

6. When the cool down is complete, the message “SELF CLEAN FINISHED” is displayed.

7. Press Oven Clear/Off to clear the display when Self Clean is finished.

8. After the oven has cooled down and the door is unlocked, wipe remaining ash from the oven using a moist cloth.

**Note:**

- The oven light cannot be turned on during self-cleaning.
- The special heat-resistant enamel and the polished components in the oven can become discolored over time. This is normal and does not affect operation. Do not use scouring pads or abrasive cleaners to treat discolorations.
- In double oven models: Self Clean is only available for one oven at a time. The other oven must be turned off.

**Avoid These Cleaners**

Do not use commercial oven cleaners such as Easy Off®. They may damage the oven finish or parts.

Never use scouring pads or abrasive cleaners.

Do not use flammable cleansers such as lighter fluid or WD-40.

Chlorine or chlorine compounds in some cleaners are corrosive to stainless steel. Check ingredients on label before using.



## Cleaning Guide

Part	Recommendations
<b>Flat Rack</b>	<p>Wash with hot soapy water. Rinse thoroughly and dry, or gently rub with cleansing powder or soap-filled pads as directed. DO NOT clean the rack in the self-cleaning oven.</p> <p>If flat racks are cleaned in the oven during the Self Clean mode, they will lose their shiny finish and may not glide smoothly. If this happens wipe the rack edges with a small amount of vegetable oil. Then wipe off excess.</p>
<b>Telescopic Rack</b>	<p>Wash with soapy water. Rinse thoroughly and dry, or gently rub with cleansing powder or soap-filled pads as directed. Avoid getting cleansing powder in the telescopic slides. Re-lubrication may become necessary. Use only high-temperature food-grade lubricants to re-lubricate slides.</p> <p>DO NOT clean the rack in the self-cleaning oven. DO NOT leave the rack in the oven during Self Clean.</p> <p>If the telescopic rack is cleaned in the oven during the Self Clean mode it will lose its shiny finish and will not glide smoothly.</p>
<b>Fiberglass Gasket</b>	DO NOT CLEAN GASKET.
<b>Glass</b>	Wash with soap and water or glass cleaner. Use Fantastik® or Formula 409® to remove grease spatters and stubborn stains.

<b>Painted Surfaces</b>	Clean with hot soapy water or apply Fantastik® or Formula 409® to a clean sponge or paper towel and wipe clean. Avoid using powder cleaning agents, steel wool pads and oven cleaners.
<b>Porcelain Surfaces</b>	Immediately wipe up acid spills like fruit juice, milk and tomatoes with a dry cloth. Do not use a moistened sponge/cloth on hot porcelain. When cool, clean with hot soapy water or apply Bon-Ami® or Soft Scrub® to a damp sponge. Rinse and dry. For stubborn stains, use soap-filled pads. It is normal for porcelain to show fine lines with age due to exposure to heat and food soil.
<b>Stainless Steel Surfaces</b>	Always wipe or rub in the direction of the grain. Clean with a soapy sponge, then rinse and dry, or wipe with Fantastik® or Formula 409® sprayed on a paper towel. Protect and polish with Stainless Steel Magic® and a soft cloth. Remove water spots with a cloth dampened with white vinegar. Do not use any abrasives such as steel wool pads, SoftScrub®, or Bon Ami®.  Chlorine or chlorine compounds in some cleaners are corrosive to stainless steel. Check ingredients on label before using.
<b>Plastic &amp; Controls</b>	When cool, clean with soapy water, rinse and dry. Do not use any abrasives such as steel wool pads, SoftScrub®, or Bon Ami®.
<b>Probe</b>	Wipe with soapy water. Do not submerge. Do not wash in the dishwasher.
<b>Printed Areas (Words and Numbers)</b>	Do not use abrasive cleansers. When cool, clean with soapy water, rinse, dry.

## Maintenance

### Replacing an Oven Light

#### WARNING

- Make sure the appliance and lights are cool and power to the appliance has been turned off before replacing the light bulb(s). Failure to do so could result in electrical shock or burns.
- The lenses must be in place when using the appliance.
- The lenses serve to protect the light bulb from breaking.
- The lenses are made of glass. Handle carefully to avoid breaking. Broken glass could cause an injury.

- Light socket is live when door is open.

**Bulb specifications:**

120 volt, 25 watt, halogen bulb, G9 base



**Replacing the halogen bulb on the oven sidewall:**

**Tools Required**

Narrow flat blade screwdriver (blade tip width 1/5" (5mm) or less to fit in slot)

Flashlight (to see socket holes to plug in bulb prongs)



1. Turn off power to the oven at the main power supply (fuse box or breaker box).
2. Remove oven racks if necessary to provide access to the bulb housing.
3. Optional: remove oven door to provide easier access and visibility.



4. Insert the tip of a narrow flat blade screwdriver between the metal clips at about a 40° angle.

**Hint:** The screwdriver blade must be able to pass between the metal clips to reach the inner catch.

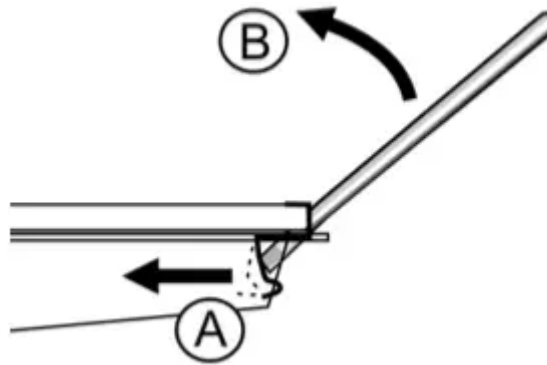

(A) Push the screwdriver blade inward to disengage the catch from the slot in the light housing.

Support the glass lens cover to prevent it from falling.

(B) Gently pry the lens off by moving the screwdriver handle away from the oven wall. The lens should detach easily. Do not attempt to force it.

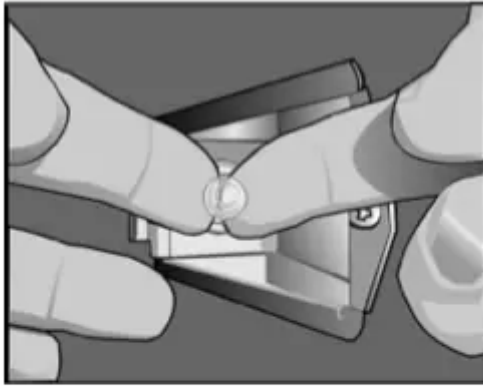

5. Pull the halogen bulb from its socket.

**Hint:** If it is difficult to grasp the bulb using one hand, use both forefingers to pinch behind the rounded part of the bulb, then pull the bulb out using both hands.

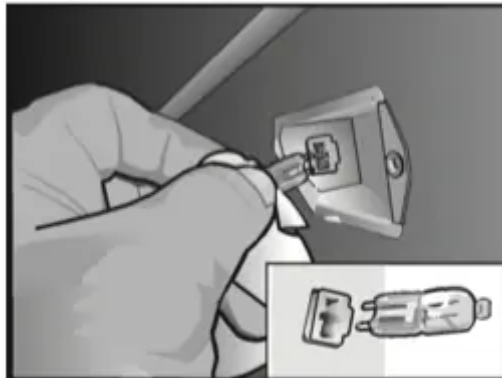

6. Replace the halogen bulb. Grasp the new bulb with a clean, dry cloth. Align the bulb prongs with the socket holes and press into place.

**Hint:** Direct finger contact with the bulb may cause premature bulb failure.

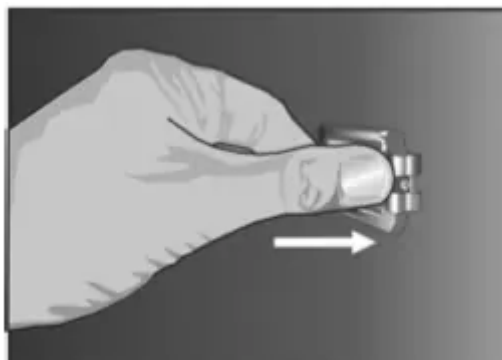

7. Put the glass cover back on by inserting it into the mounting clip and pressing the end nearest you into the housing until it locks into place.

8. Turn power back on at the main power supply (fuse or breaker box).

## Removing the Oven Door

### WARNING

When removing the door:

- Make sure oven is cool and power to the oven has been turned off before removing the door. Failure to do so could result in electrical shock or burns.
- The oven door is heavy and parts of it are fragile. Use both hands to remove the oven door. The door front is glass. Handle carefully to avoid breakage.
- Grasp only the sides of the oven door. Do not grasp the handle as it may swing in your hand and cause damage or injury.
- Failure to grasp the oven door firmly and properly could result in personal injury or product damage.
- To avoid injury from hinge bracket snapping closed, be sure that both levers are securely in place before removing the door. Also, do not force door open or closed—the hinge could be damaged and injury could result.
- Do not lay removed door on sharp or pointed objects as this could break the glass. Lay on a flat, smooth surface, positioned so that the door cannot fall over.

**To remove the oven door:**

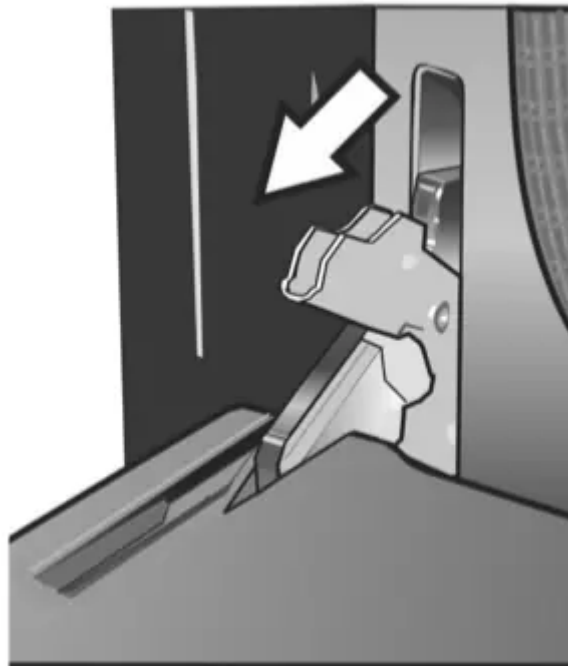

To help avoid injury or damage be sure to read the above WARNING before attempting to remove the oven door.

1. Open the oven door to its fully open, horizontal position.
2. Flip levers on hinges toward you.

**Note:** It may be necessary to use a tool, such as a screwdriver, to gently pry the upper part of the lever away from the housing. Take care to avoid scratching the housing.

3. Bring both door hinge levers to their fullest down position as shown in the illustration. The left and right door hinges differ slightly but operate in the same manner.



4. Close the oven door until it catches on the hinge stop levers, locking the hinges at the proper angle for door removal. The door will be open about 7 inches at the top. This takes the spring tension off the hinges so the door can be easily lifted out.

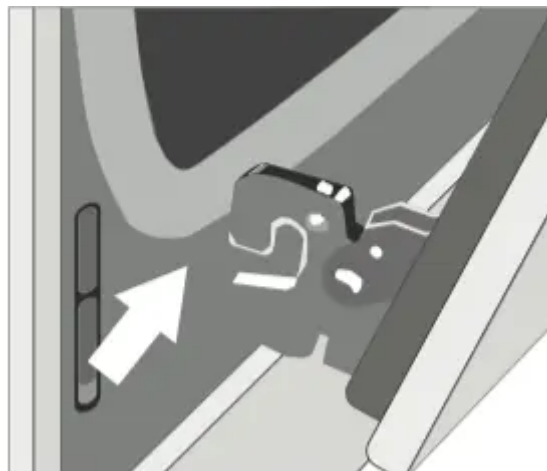

5. The door is heavy. Use both hands to firmly grip it by the sides. Do not grip the door by the handle. Maintaining the door angle, lift the door straight up approximately 3/4" to unhook

the hinges from the slots and then pull it out towards you until the hinges are clear of the oven housing.

6. Place the door in a convenient and stable location for cleaning.

**To replace the oven door:**

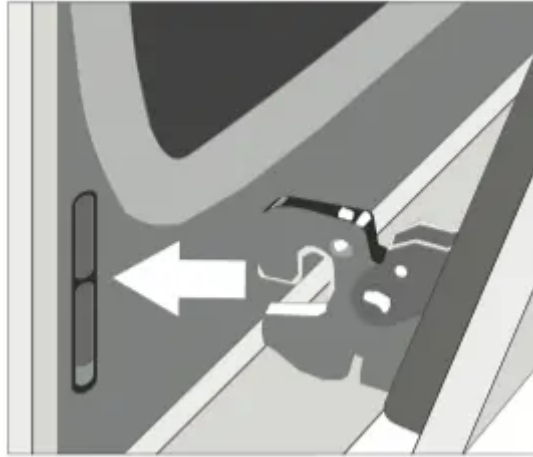

1. Holding the door firmly in both hands, grip it on either side, not by the handle.
2. Tilt the door back slightly towards you until it opens about 7" at the top.
3. Slide the hinges into the slots as far as they will go and then lower the door straight down. The angle of the door may need to be adjusted slightly to allow the hinges to engage properly and the door to lower into place. The door should lower about 3/4" and stop. If not, the hinges have not engaged properly and the door could fall if it is released.
4. Once both hinges are fully engaged as described in Step 3, gently open the door until it is fully open.

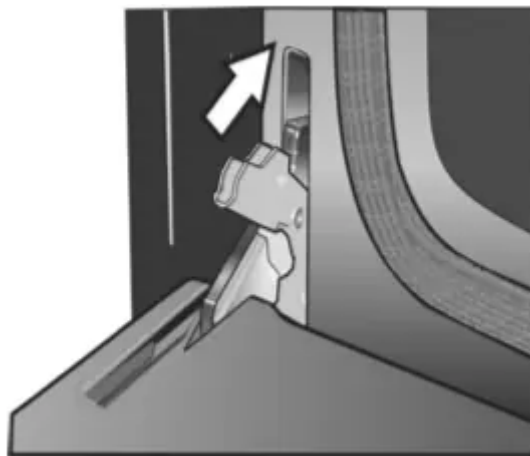

5. Push the levers on both the hinges up and forward until they are locked into the slot, flush with the front of the oven body.
6. Close and open door slowly to be sure it is correctly and securely in place.

# Service

## How to Obtain Service or Parts

To reach a service representative, see the contact information at the front of the manual. Please be prepared with the information printed on your product data plate when calling.

## Product Data Plate

The data plate shows the model and serial number. Refer to the data plate on the appliance when requesting service. The data plate location varies based on the oven model and door hinge type:

- Single oven with bottom hinge: left hand side of door trim.
- Single oven with side hinge: side opposite the door hinge.
- Double oven with bottom hinge: left hand side of door trim of the lower oven cavity.
- Double oven with side hinge: side opposite the door hinge of the lower oven cavity.

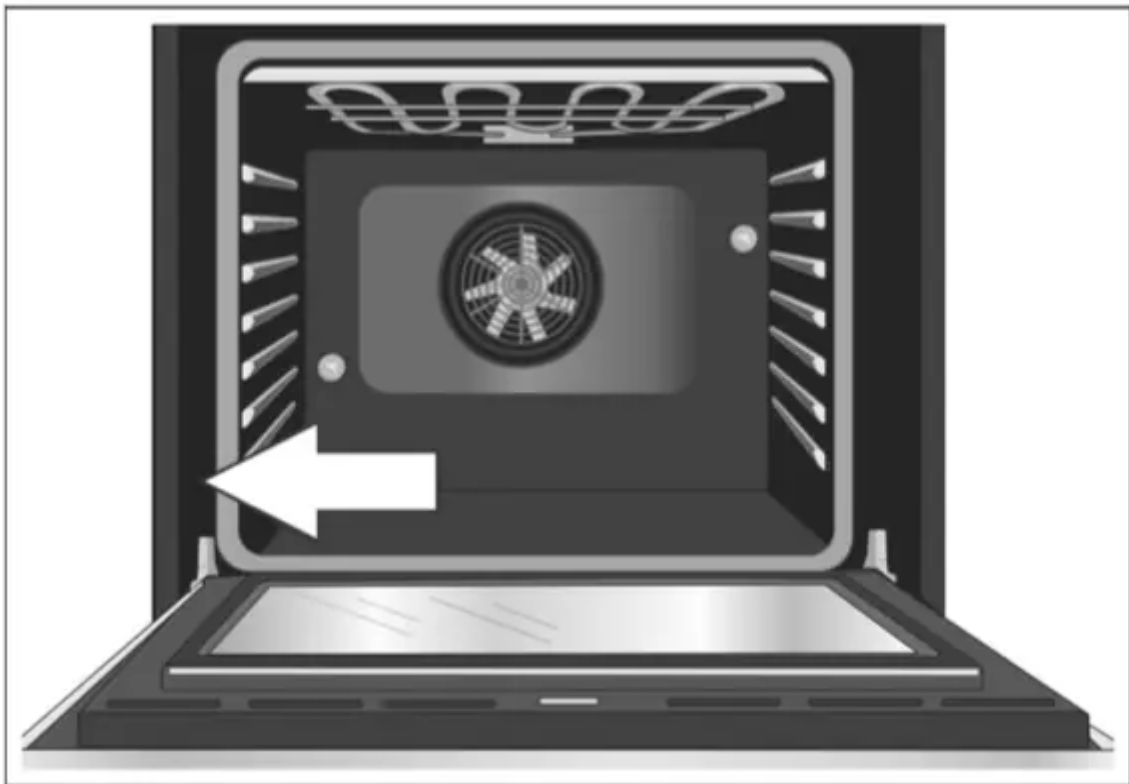

## Self Help

### Troubleshooting Chart

Use these suggestions before calling for service to avoid service charges.

<b>Oven Problem</b>	<b>Possible Causes and Suggested Solutions</b>
<b>Oven door is locked and will not open, even after cooling.</b>	Turn the oven off at the circuit breaker and wait five minutes. Turn breaker back on. The oven should reset itself and will be operable.
<b>Oven is not heating.</b>	Check circuit breaker or fuse box to your house. Make sure there is proper electrical power to the oven. Be sure oven temperature has been selected.
<b>Oven is not cooking evenly.</b>	Refer to cooking charts for recommended rack position. Check "Getting the Most Out of Your Appliance" for tips and suggestions.
<b>Baking results are not as expected.</b>	Refer to cooking charts for recommended rack position. Check "Getting the Most Out of Your Appliance" for tips and suggestions. Adjust oven calibration if necessary. See "Oven Temperature Offset" under "Settings Menu Options".
<b>Food takes longer to cook than expected.</b>	The oven is carefully calibrated to provide accurate results. However, the temperature can be offset if food is consistently too brown or too light. See "Oven Temperature Offset" under "Settings Menu Options".
<b>Food is overcooked.</b>	The oven is carefully calibrated to provide accurate results. However, the temperature can be offset if food is consistently too brown or too light. See "Oven Temperature Offset" under "Settings Menu Options".
<b>Oven light is not working properly.</b>	Replace or reinsert the light bulb if loose or defective. Touching the bulb with fingers may cause the bulb to burn out.



<b>Oven light does not turn off.</b>	Check for obstruction in oven door. Check to see if hinge is bent.
<b>Cannot remove lens cover on light.</b>	There may be soil build-up around the lens cover. Wipe lens cover area with a clean, dry towel prior to attempting to remove the lens cover.
<b>Oven is not self-cleaning properly.</b>	Allow the oven to cool before running Self Clean. Always wipe out loose soils or heavy spillovers before running Self Clean. If oven is badly soiled, set oven for the maximum Self Clean time.
<b>Clock and timer are not working properly.</b>	Make sure there is electrical power to oven.
<b>"E" and a number appears in display and control beeps.</b>	This is a fault code. Press any key to stop beeping. Reset oven if necessary. If fault code remains, record fault code, cancel oven, and call authorized service technician.
<b>With a new oven there is a strong odor when oven is turned on.</b>	This is normal with a new oven and will disappear after a few uses. Operating the Self Clean cycle also "burns-off" the smell more quickly.
<b>Control does not react when a key is touched.</b>	Be sure that surface is clean and dry. Touch the center of the button. Use the flat part of your finger.
<b>Warm air or steam escapes from oven vent.</b>	It is normal to see or feel steam or warm air escaping from the oven vent. Do not block the vent.
<b>Cooling fan runs even when the oven is turned off.</b>	This is normal. The cooling fan will continue to run, even after the oven has been turned off, until the oven has cooled sufficiently.

### **Warning**

This content is compiled from multiple sources and is provided for reference purposes only. It may not be complete or fully applicable to all situations. If you are unable to resolve your issue, please contact the product manufacturer or an authorized service provider for official support.



