

PART NAMES

FRONT VIEW

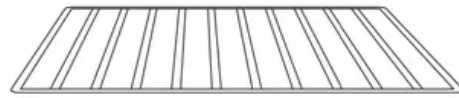

(Do not leave rack in microwave unless cooking on rack.)

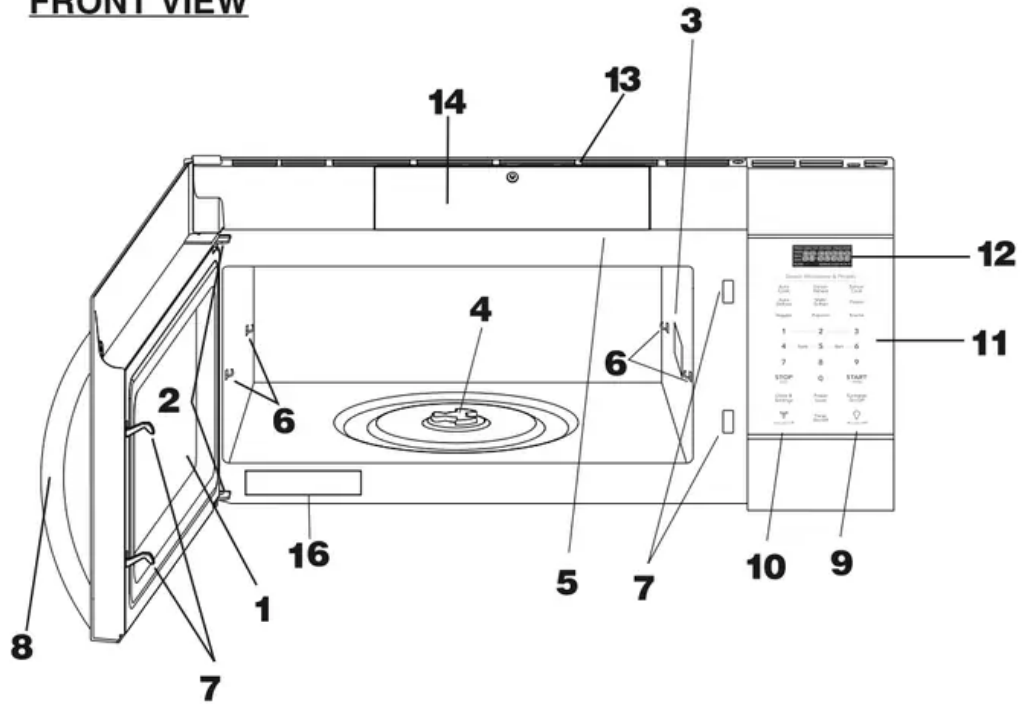

BOTTOM VIEW

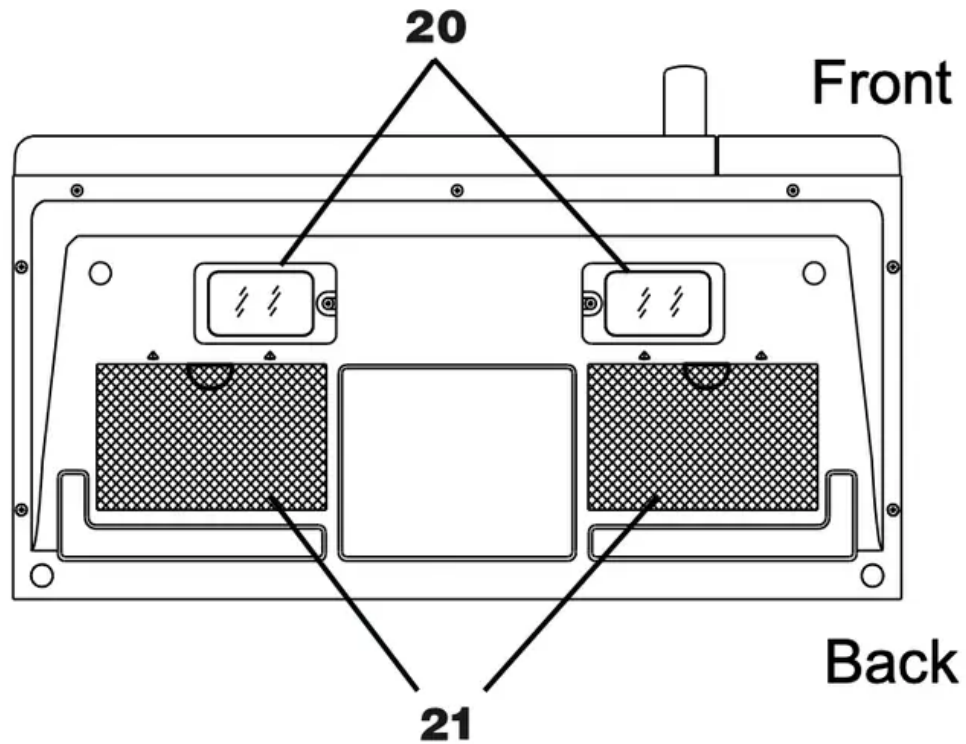

1. Microwave oven door with see-through window
2. Door hinges
3. Waveguide cover:
DO NOT REMOVE.
4. Turntable motor shaft
5. Microwave oven light
It will light when microwave oven is operating or door is open.
6. Rack holders
7. Safety door latches
The microwave oven will not operate unless the door is securely closed.
8. Handle
9. Light hi/lo/off pad Press the light hi/lo/off pad once for high, twice for low and three times to turn off the light.
10. Vent hi/lo/off pad
Press the vent hi/lo/off pad once for high speed, twice for low speed and three times to turn off the fan.
11. Auto-Touch control panel
12. Time display: Digital display, 99 minutes, 99 seconds

13. Ventilation openings
14. PureAir® Filter Access Door
15. PureAir® Microwave Carbon Filter
16. Menu label
17. Removable turntable

The turntable will rotate clockwise or counter-clockwise. Only remove for cleaning.

18. Removable turntable support

First, carefully place the turntable support on the motor shaft in the center of the microwave oven floor. Place the support ring on the microwave oven floor. Then, place the turntable on the turntable support securely.

19. Rack for 2-level cooking/ reheating
20. Light cover
21. Grease filters

CONTROL PANEL

The 7-digit Interactive Display spells out operating steps and shows cooking hints.

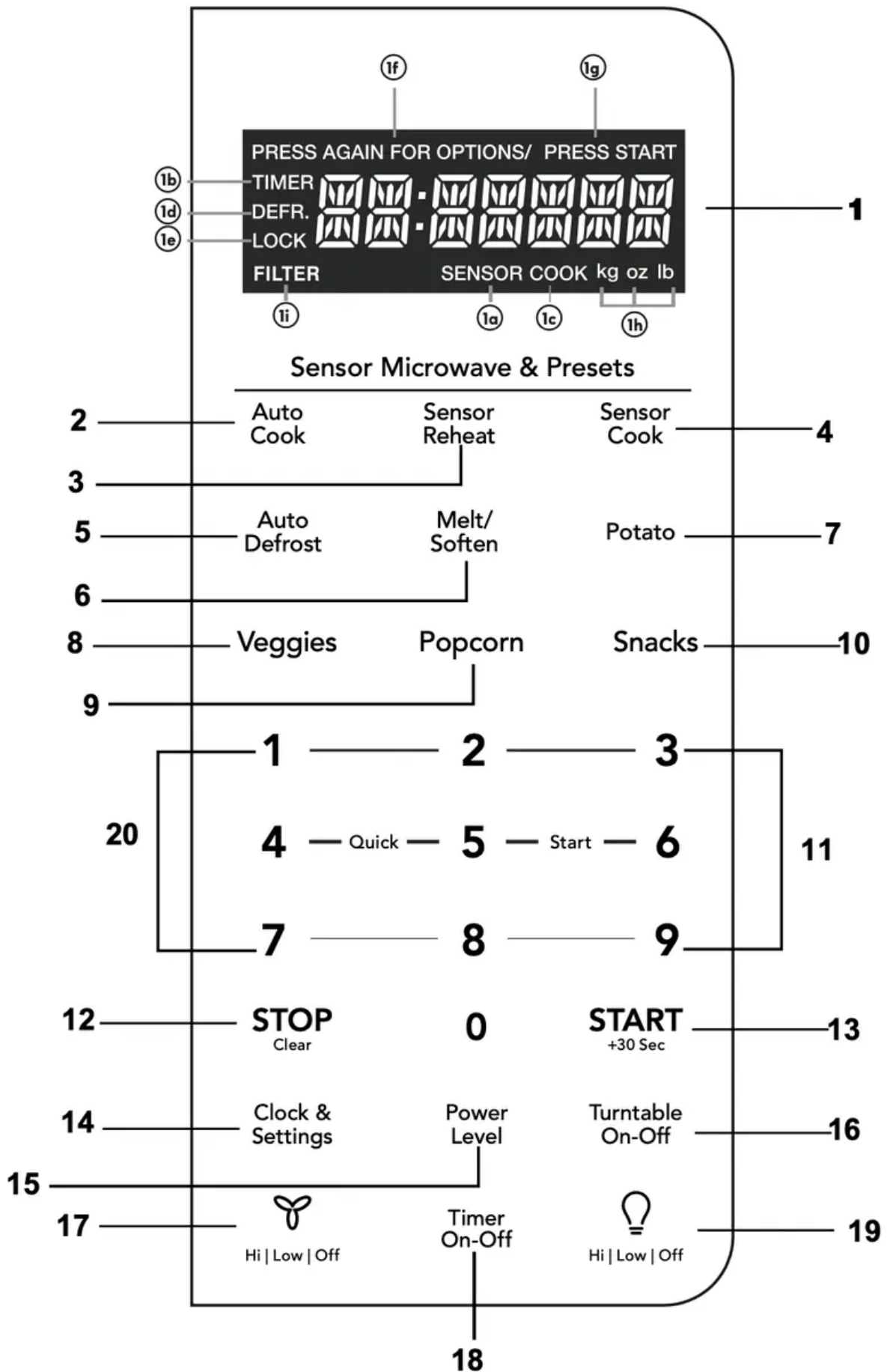

Number next to the control panel key illustration indicates pages on which there are feature descriptions and usage information.

1. Display:

The display includes a clock and indicators that show the time of day, cooking time settings, cook powers, sensor, quantities, weights and cooking functions selected.

1a. SENSOR: Icon displayed when using sensor cook.

1b. TIMER: Icon displayed when timer is being set or running.

1c. COOK: Icon displayed when starting microwave cooking.

1d. DEFROST: Icon displayed when defrosting food.

1e. LOCK: Icon displayed in control lock.

1f. PRESS AGAIN FOR OPTIONS: Icon displayed when additional options are available.

1g. PRESS START: Icon displayed when a valid function can be started.

1h. kg, oz, lb: Icon displayed when choosing the weight.

1i. FILTER: Icon displayed replace PureAir ® Filter.

2. **Auto Cook (P18)**
3. **Sensor Reheat (5 different settings) (P14)**
4. **Sensor Cook (P13)**
5. **Auto Defrost (P21)**
6. **Melt Soften (P17)**
7. **Potato (1-4 potatoes) (P16)**
8. **Veggies (P15)**
9. **Popcorn (P15)**
10. **Snacks (P16)**
11. **Numeric pads (0 thru 9)**
12. **Stop/Clear (P10)**
13. **START +30 sec (P11)**
14. **Clock & Settings (P10) (P25)**
15. **Power Level (11power levels available) (P12)**
16. **Turntable (On-Off)(P28)**
17. **Exhaust (High/Low/Off) ~ Use to turn the exhaust fan off, or to adjust fan speed. (P28)**
18. **Timer (On-Off)(P28)**
19. **Surface Light (High/Low/Off) ~ Press this pad to adjust the brightness of surface lights. (P28)**
20. **Quick Start (9 instant key settings) (P10)**

Note: For detailed information, please go to relative page listed above.

BEFORE OPERATING

- Before operating your new oven make sure you read and understand this Use and Care Guide completely.
- The clock can be disabled when the microwave is first plugged in and the STOP key is selected.
To re-enable the clock follow clock instructions.

To Set the Clock

- Suppose you want to enter the correct time of day 10:59

Touch:

Display Shows:

1. **Clock & Settings**

PRESS AGAIN FOR OPTIONS/
12:00 ENTER TIME

2. (1) (0) (5) (9)

10:59
PRESS START

3. **START**
+30 Sec

10:59

NOTE

1. If you begin to enter in an incorrect time (e.g. 2:89) the 8 is an invalid digit and cannot be entered.
Enter the correct time.
2. If you touch **STOP Clear** while setting the clock, the display will show the last time of day set or a blank display if no time of day has been set.

STOP clear

Press the **STOP Clear** to:

1. Erase if you make a mistake during programming.
2. Cancel timer setting and the signal after cooking.
3. Stop the oven temporarily during cooking.

4. Return the time of day to the display.
5. Cancel a program during cooking, press twice.

MANUAL COOKING

Time Cooking

Your Over the Range Microwave Oven can be programmed for 99 minutes 99 seconds (99 :99). Always enter the seconds after the minutes, even if they are both zeros.

- Suppose you want to cook for 5 minutes, 30 seconds at 100% power,

Touch:	Display Shows:
1. 5 3 0	<div style="text-align: right; font-size: 0.8em; margin-bottom: 5px;">PRESS START</div> <div style="font-size: 2.5em; font-family: monospace;">5:30</div>
2. START +30 Sec	<div style="font-size: 2.5em; font-family: monospace; margin-bottom: 5px;">5:30</div> <div style="text-align: right; font-size: 0.8em; margin-bottom: 5px;">COOK</div> <div style="font-weight: bold; font-size: 1.2em;">Time counting down</div>

Interrupting Cooking

You can stop the oven during a cycle by opening the door. The oven stops heating and the fan turns off, but the light stays on.

To restart cooking, close the door and Touch.

START
+30 Sec

STOP
Clear

If you do not want to continue cooking, open the door and touch

Using One Touch Start

This is a time saving pad that will automatically start cooking 2 seconds after selected. Numeric key 1, 2, or 3 can be touched for a 1 minute, 2 minute or 3 minute automatic start cooking feature.



Touch:

Display Shows:

1. **2**

2:00
COOK

Time counting down

NOTE: "Food" will be displayed if a quick start cooking cycle or +30 sec key is not selected within 5 minutes of placing food in the microwave. You must open then close the door again to clear "Food" from the display.

Using Add 30 Sec.

This is a time-saving pad. It is a simplified feature that lets you quickly set and start microwave cooking at 100% power.

- Suppose you want to cook for one minute.

Touch:

Display Shows:

1. **START**
+30 Sec

:30
COOK

2. **START**
+30 Sec

1:00
COOK

Time counting down

NOTE: "Food" will be displayed if a quick start cooking cycle or +30 sec key is not selected within 5 minutes of placing food in the microwave. You must open then close the door again to clear "Food" from the display.

Setting Timed Cooking With Power Level

This feature lets you program a specific cook time and power. For best results, there are 10 power level settings in addition to HIGH (100%) power.

- Suppose you want to cook for 5 minutes, 30 seconds at 80% power.

Touch:

Display Shows:

1. (5) (3) (0)

PRESS START
5:30

2. Power Level x 3

PRESS START
PL-80

3. START
+30 Sec

5:30
COOK
Time counting down

NOTE: If you do not select a power level, the oven will automatically cook at HIGH (100%) power.

Setting Two-Stage Cooking

For best results, some recipes call for different power levels during a cook cycle . You can program your oven for two power level stages during the cooking cycle.

- Suppose you want to set a 2-stage cook cycle. The first stage is a 3 minute cook time at 80% cook power then a 7 minute cook time at 50% cook power.

Touch:

Display Shows:

1. (3) (0) (0)

To set a 3 minute cook time for first stage.

3:00 PRESS START

2. Power Level x 3

PL-80 PRESS START

3. (7) (0) (0)

To set a 7 minute cook power for the second stage.

7:00 PRESS START

4. Power Level x 6

PL-50 PRESS START

5. **START**
+30 Sec

3:00 COOK
Time counting down

NOTE: You can program a "0" power second stage for standing time inside the oven.

To Set Power Level

There are eleven preset power levels.

Using lower power levels increases the cooking time which is recommended for foods such as cheese, milk and long slow cooking of meats. Consult cookbook or recipes for specific recommendations.

PRESS POWER LEVEL PAD NUMBER OF TIMES FOR DESIRED POWER	APPROXIMATE PERCENTAGE OF POWER	COMMON WORDS FOR POWER LEVELS
POWER LEVEL x 1	100%	High
POWER LEVEL x 2	90%	
POWER LEVEL x 3	80%	
POWER LEVEL x 4	70%	Medium High
POWER LEVEL x 5	60%	
POWER LEVEL x 6	50%	Medium
POWER LEVEL x 7	40%	
POWER LEVEL x 8	30%	Med Low/Defrost
POWER LEVEL x 9	20%	
POWER LEVEL x 10	10%	Low
POWER LEVEL x 11	0%	

NOTE: DO NOT STORE THE RACK IN THE MICROWAVE WHEN NOT IN USE.

Using the Rack

The rack allows several foods to be cooked or reheated at one time. However, for the best cooking and reheating, use Turntable ON function and cook with SENSOR COOKING or AUTO COOKING without the rack. When the rack is used, set time and power level manually. Allow plenty of space around and between the dishes. Pay close attention to the cooking and reheating progress. Reposition the foods and reverse them from the rack to turntable and/or stir them at least once during any cooking or reheating time. After cooking or reheating, stir if possible. Using a lower power level will assist in better cooking and reheating uniformity.

Avoid:

- Storing the rack in the microwave oven when not in use.
- Popping popcorn with the rack in the microwave oven.
- Using any browning dish on the rack.
- Using SENSOR COOKING and AUTO COOKING with the rack.
- Cooking directly on the rack—use microwave-safe cookware.

NOTE: Turntable on/off function can be used in Manual Operation. See page 28.

Manual Defrost

If the food that you wish to defrost is not listed on the Defrost chart or is above or below the limits in the Amount column on the Defrost chart (see page 22-23), you need to defrost manually.

You can defrost any frozen food, either raw or previously cooked, by using power level for 30%.

For either raw or previously cooked frozen food the rule of thumb is approximately 4 minutes per pound. For example, defrost 4 minutes for 1 pound of frozen spaghetti sauce.

Always stop the oven periodically to remove or separate the portions that are defrosted. If food is not defrosted at the end of the estimated defrosting time, program the oven in 1 minute increments on power level 30% until totally defrosted.

When using plastic containers from the freezer, defrost only long enough to remove from the plastic in order to place in a microwave-safe dish.

SENSOR COOKING

Sensor cooking has an electronic controlled sensor that detects the vapor (moisture and humidity) emitted from the food as it heats. The sensor adjusts the cooking times and power level for various foods and quantities automatically.

Using Sensor Settings:

1. Be sure the exterior of the cooking container and the interior of the oven are dry. Wipe off any moisture with a dry cloth or paper towel.
2. The oven works with foods at normal storage temperature. For example, popcorn would be at room temperature.
3. More or less food than the quantity listed in the chart should be cooked following the guidelines in any microwave cookbook.
4. During the first part of SENSOR COOKING, food name will appear in the display. Do not open the oven door or press the STOP clear pad during this part of the cycle. The measurement of vapor will be interrupted. When the sensor detects the vapor emitted from the food, remainder of cooking time will appear. Door may be opened when remaining cooking time appears in the display. At this time, you may stir or season food, as desired.
5. If the sensor does not detect vapor properly when popping popcorn, the oven will turn off, and the correct time of day will be displayed. If the sensor does not detect vapor properly when cooking other foods, AN ERROR CODE will be displayed, and the oven will turn off.
6. Check food for temperature after cooking. If additional time is needed, continue to cook manually.

Covering Foods:

Some foods cook better when covered.

1. Casserole lid.
2. Plastic wrap: Use plastic wrap recommended for microwave cooking. Cover dish loosely; allow approximately 1 /2 inch to remain uncovered to allow steam to escape. Plastic wrap should not touch food.
3. Wax paper: Cover dish completely; fold excess wrap under dish to secure. If dish is wider than paper, overlap two pieces at least one inch to cover.

Be careful when removing any covering to allow steam to escape away from you.

NOTES for SENSOR COOKING

1. The final cooking result will vary according to the food condition (e.g. initial temperature, shape, quality). Check food for temperature after cooking. If additional time is needed, continue to cook manually.
2. Stay near the oven while it's in use and check cooking progress frequently so that there is no chance of overcooking food.
3. When SENSOR COOKING is selected Turntable On is automatically set for optimum cooking.

Sensor Cook

You can cook foods by pressing the sensor cook pad multiple times. You don't need to calculate cooking time or power level.

- Suppose you want to cook frozen breakfast .

Touch:**Display Shows:**

1. Sensor
Cook

PRESS AGAIN FOR OPTIONS/ PRESS START

BACON
SENSOR

2. Sensor
Cook

PRESS AGAIN FOR OPTIONS/ PRESS START

FROZEN DINNER
SENSOR

3. Sensor
Cook

PRESS AGAIN FOR OPTIONS/ PRESS START

RICE
SENSOR

4. Sensor
Cook

PRESS AGAIN FOR OPTIONS/ PRESS START

FROZEN BREAKFAST
SENSOR

5. START
+30 Sec

FROZEN BREAKFAST

SENSOR COOK

Sensor Cook chart

FOOD	AMOUNT	PROCEDURE
1. Bacon	1-3 slices	Place bacon strips on a microwave bacon rack for best results. (Use dinner plate lined with paper towels if rack is not available).
2. Frozen Dinner	10 oz./ 20 oz.	Place in an appropriately sized microwave container. Cover with plastic wrap . After cooking, stir and allow to stand for 3 minutes.
3. Rice	1-2 cups Use medium or long grain rice. Cook instant rice according to directions on the package.	Place rice and twice as much liquid (water, chicken or vegetable stock) in a 2 quart microwave dish. Cover with plastic wrap and vent. After cooking, allow to stand for 10 minutes. Stir for fluffier rice.
4. Frozen Breakfast	8/12 oz.	Place in an appropriately sized microwave container. Cover with plastic wrap . After cooking, stir and allow to stand for 3 minutes.

Sensor Reheat

- Suppose you want to reheat rolls with sensor reheat.

Touch:

Display Shows:

1. Sensor
Reheat

PRESS AGAIN FOR OPTIONS/ PRESS START
BEVERAGE

2. Sensor
Reheat

PRESS AGAIN FOR OPTIONS/ PRESS START
DINNER PLATE
SENSOR

3. Sensor
Reheat

PRESS AGAIN FOR OPTIONS/ PRESS START
SOUP SAUCE
SENSOR

4. Sensor
Reheat

PRESS AGAIN FOR OPTIONS/ PRESS START
CASSEROLE
SENSOR

Touch:

Display Shows:

5. Sensor
Reheat

PRESS AGAIN FOR OPTIONS/ PRESS START
ROLLS
SENSOR

6. START
+30 Sec

ROLLS
SENSOR COOK

Sensor Reheat chart

FOOD	AMOUNT	PROCEDURE
Beverage	1 - 3 cups	To reheat beverages. Stir liquid briskly before and after heating to avoid "eruption"
Dinner Plate	1-2 Plates	Place on a low plate. Cover with vented plastic wrap. Let stand 3 minutes after cooking.
Soup/Sauce	1-2 Cups	Place in shallow microwavable casserole. Cover with vented plastic wrap. After cooking, stir and let stand 3 minutes.
Casserole/ Lasagna	1-4 Servings	Place in a microwavable bowl or casserole. Cover with vented plastic wrap. After cooking, stir and let stand 3 minutes.
Roll/Muffin	1-3 Pieces	Place on paper towel. Do not cover.

ONE TOUCH COOK

Popcorn

The Popcorn quick touch pad lets you pop 3.3, 3.0, 1.75 ounce bags of commercially packaged microwave popcorn. Pop only one package at a time. If you are using a microwave popcorn popper, follow manufacturer's instructions.

- Suppose you want to pop a 3.3 oz. popcorn.

Touch:

Display Shows:

1. Popcorn

PRESS AGAIN FOR OPTIONS/ PRESS START

3.3

oz

2. **START**
+30 Sec

POPCORN

COOK

Time counting down

Amount

Press popcorn pad

3.30 oz.

once

3.00 oz.

2 times

1.75 oz.

3 times

NOTES: Remove the metal shelf from microwave oven when cooking popcorn. Do not use regular paper bags. Do not re-pop unpopped kernels. Do not pop popcorn in glass cookware.

Veggies

There are 2 options (Frozen Vegetables , Fresh Vegetables under the Veggies.

- Suppose you want to cook two cups of frozen veggies.

Touch:

Display Shows:

1. Veggies

PRESS AGAIN FOR OPTIONS/ PRESS START

FRESH

2. Veggies

PRESS AGAIN FOR OPTIONS/ PRESS START

FROZEN

3. START
+30 Sec

FROZEN VEGGIES

COOK

Time counting down

Vegetables chart

FOOD (Initial temperature)	AMOUNT	PROCEDURE
1. Frozen Vegetables (-18 °C)	4 - 24 oz 0.2 - 0.7 kg	Add no water. Cover with lid or plastic wrap. Press the vegetables pad two times for Frozen Vegetables . After cooking, stir and let stand, covered, for 3 minutes.
2. Fresh Vegetables (5 °C) Broccoli Brussels sprouts Cabbage Cauliflower (flowerets) Cauliflower (whole) Spinach Zucchini	4 - 24 oz 0.2 - 0.7 kg	Wash and place in casserole. Add no water if vegetables have just been washed. Cover with lid for tender vegetables. Use plastic wrap for tender-crisp vegetables. Press the vegetables pad one time for fresh Vegetables . After cooking, stir, if possible. Let stand, covered, for 2 to 5 minutes.
Carrots, sliced Corn on cob Green beans Winter squash - diced - halves		Place in casserole. Add 1-4 tbsp. water. Cover with lid for tender vegetables. Use plastic wrap cover for tender-crisp vegetables. Press the vegetables pad one time for fresh vegetables. After cooking stir, if possible. Let stand, covered, for 2 to 5 minutes.

Snack Menu

Snack Menu is for cooking/heating foods that take a short amount of time!

- Suppose you want to reheat 3 hotdogs.

Touch:

Display Shows:

1. Snacks

PRESS AGAIN FOR OPTIONS/ PRESS START
FROZEN PIZZA

2. Snacks

PRESS AGAIN FOR OPTIONS/ PRESS START
HOT DOGS

3. START
+30 Sec

1-6

4. 3

PRESS START
3

5. START
+30 Sec

HOT DOGS
COOK

Time counting down

Snack Menu chart

FOOD	AMOUNT	PROCEDURE
1. Frozen MW Pizza	(6 - 8 oz) (170 - 225 g)	Use for frozen microwave pizza. Remove from package and unwrap. Follow package directions for use of package and/or silver crisping disk.
2. Hot Dogs	1 - 6 pieces	Place hot dog in bun. Wrap each with paper towel or napkin.
3. Meal in a Cup	2.39 oz	This setting is ideal for individual portions of canned food packed in a small microwaveable container, usually 6 to 8 ounces. Remove inner metal lid and replace outer microwaveable lid. After cooking, stir food and allow to stand 1 or 2 minutes.
4. Frozen Kid's Meal	8.8 oz	Use this pad for frozen, convenience foods. It will give satisfactory results for most brands. You may wish to try several and choose your favorite. Remove package from outer wrapping and follow package directions for covering. After cooking, let stand, covered for 1 to 3 minutes.

Potato

- Suppose you want to cook 1 to 4 baked Potatoes.

Touch:

Display Shows:

1. Potato

PRESS START
POTATO
SENSOR

**2. START
+30 Sec**

POTATO
SENSOR COOK

NOTES: Cooking times are based on an average 8 ounce potato.

Baked Potato chart

FOOD	AMOUNT	PROCEDURE
Potato*	1 - 4 pieces	Pierce with fork in several places. Place on paper towel on turntable. After cooking, remove from oven and let stand for 5 minutes.

* It is not necessary to enter amount or number.

Setting Melt/Soften

The oven uses low power to melt and soften items. See the following table.

- Suppose you want to melt 2 sticks of Butter.

Touch:**Display Shows:**

**1. Melt/
Soften**

PRESS AGAIN FOR OPTIONS/ PRESS START
MELT BUTTER

**2. START
+30 Sec**

ENTER 1-2 STK

3. ②

PRESS START
2 STICK

**4. START
+30 Sec**

MELT BUTTER

COOK
Time counting down

CATEGORY	AMOUNT	DIRECTION
BUTTER	1 or 2 sticks	Unwrap and place in microwavable container. No need to cover butter. Stir at the end of cooking to complete melting.
CHOCOLATE	2, 4 or 8 oz.	Chocolate chips or squares of baking chocolate may be used. Unwrap squares and place in microwavable container. Stir at the end of cycle to complete melting.
ICE CREAM	Pint, 1.5 Quart.	Place container in oven. Ice cream will be soft enough to make scooping easier.
CREAM CHEESE	3 or 8 oz.	Unwrap and place in microwavable container. Cream cheese will be at room temperature and ready for use in recipe.

AUTO COOKING

Auto Cook

Auto cook is divided into 2 parts-Quick Meals (Scrambled Eggs, Hot Cereal, Frozen Pizza, Fudge Brownies) and Dinner Recipes (Garlic Shrimp, Asiago Red Potatoes, Roasted Vegetable Medley, Lemon and Shrimp Risotto, White Chicken Chili).

Key	Food	Amount
Auto Cook x1	Scrambled Eggs	1 - 6 Eggs
Auto Cook x2	Hot Cereal	1 - 3 Servings
Auto Cook x3	Frozen Pizza	12 oz
Auto Cook x4	Fudge Brownies	18 oz
Auto Cook x5	Garlic Shrimp	Per Recipe
Auto Cook x6	Stuffed Mushrooms	Per Recipe
Auto Cook x7	Asiago Red Potatoes	Per Recipe
Auto Cook x8	Roasted Vegetable Medley	Per Recipe
Auto Cook x9	Lemon and Shrimp Risotto	Per Recipe
Auto Cook x10	White Chicken Chili	Per Recipe

<Quick Meals>

- Suppose you want to cook Hot Cereal for 1 serving .

Touch:**Display Shows:**

1. **Auto Cook**

PRESS AGAIN FOR OPTIONS/ PRESS START
SCRAMBLED EGGS

2. **Auto Cook**

PRESS AGAIN FOR OPTIONS/ PRESS START
HOT CEREAL

3. **START**
+30 Sec

1-3 SERVING

4. **3**

PRESS START
3 SERVINGS

5. **START**
+30 Sec

HOT CEREAL
COOK
Time counting down

NOTES: When AUTO COOKING is selected, Turntable On is automatically set for optimum cooking.

Quick Meals chart

FOOD	AMOUNT	PROCEDURE
1. Scrambled Eggs	1 - 6 eggs	Whisk together egg and milk (use 1/2 tablespoon milk for each egg) in a microwave safe bowl that has been coated with cooking spray. Select "Scrambled Eggs" under the Auto Cook menu and the desired number of eggs to be cooked. Stir half way through cooking time.
2. Hot Cereal	1- 3 servings	Use individual packets or bulk cereal in your favorite variety: oatmeal, oat bran, cream of wheat, farina or wheatena. Follow package directions for the correct amount of water or milk. To prevent boilovers, it is very important to choose a large container because microwave cooking of cereal causes high boiling. Select "Hot Cereal" under the Auto Cook menu and the desired number servings.
3. Frozen Pizza	12 oz	Use for frozen microwave pizza. Remove from package and unwrap. Follow package directions for use of package and/or silver crisping disk.
4. Fudge Brownies	18-19 oz	Prepare brownie mix according to package directions. Spoon batter into an 8 x 8 inch microwave safe glass dish that has been coated with cooking spray. Select "Fudge Brownies" under the Auto Cook menu.

<Dinner Recipes>

- Suppose you want to cook Garlic shrimp.

Touch:

Display Shows:

1. Auto
Cook

PRESS AGAIN FOR OPTIONS/ PRESS START
SCRAMBLED EGGS

2. Auto
Cook

PRESS AGAIN FOR OPTIONS/ PRESS START
HOT CEREAL

3. Auto
Cook

PRESS AGAIN FOR OPTIONS/ PRESS START
FROZEN PIZZA

4. Auto
Cook

PRESS AGAIN FOR OPTIONS/ PRESS START
FUDGE BROWNIES

5. Auto
Cook

PRESS AGAIN FOR OPTIONS/ PRESS START
GARLIC SHRIMP

6. START
+30 Sec

GARLIC SHRIMP
COOK
Time counting down

<Dinner Recipes

Garlic Shrimp

- ¼ cup butter
- 6 cloves garlic, minced
- 2 tablespoons chopped fresh chives
- 2 tablespoons lemon juice
- 1 tablespoon chili pepper paste
- Salt to taste
- 1 pound raw, peeled and deveined large shrimp

Place butter in a 2 quart microwave safe casserole dish with lid. Microwave on High power for 1 minute or until butter is melted. Stir in garlic, and microwave for an additional 1 minute. Stir in chives, lemon juice, chili pepper paste, and salt. Add shrimp, tossing to coat evenly. Cover, and microwave on High power for 5 minutes, or until shrimp is opaque, stirring after 3 minutes. Serve over hot cooked rice if desired.

Stuffed Mushrooms

- 1 pound whole baby bella mushrooms
- 2 tablespoons butter, melted
- 1 bunch green onion, chopped
- ¼ cup shredded Parmesan cheese
- 2 tablespoons bread crumbs
- 1 teaspoon lemon juice
- ¼ teaspoon garlic pepper
- Crushed red pepper to taste

Remove stems from mushrooms and set aside. Arrange mushroom caps on microwave safe plate. Finely chop reserved mushroom stems. Combine butter, chopped mushroom stems, and green onion in a 1 quart microwave safe dish; microwave on High power for 2 minutes. Add remaining ingredients and mix well. Spoon stuffing into mushroom caps. Microwave on High power for 4 to 5 minutes, or until mushrooms are tender.

Asiago Red Potatoes

- 1 ¼ pound red potatoes, peeled and thinly sliced
- 2 tablespoons all purpose flour
- ½ teaspoon salt
- 1 ¼ cups milk
- 1 tablespoon butter, melted
- 5 ounces shredded Asiago cheese

Combine potatoes, flour, and salt in a zip top plastic bag; seal bag and shake to coat potatoes.

Transfer potatoes to a lightly greased 2 quart microwave safe casserole dish. Add milk and butter, stirring well. Cover and microwave on 80% power for 12 minutes or until potatoes are tender; sprinkle with cheese and microwave on 80% power for an additional 3 minutes or until cheese melts.

Roasted Vegetables Medley

- 1 cup baby carrots
- 1 cup sliced yellow squash

- 1 cup sliced zucchini
- ½ cup sliced red bell pepper
- ½ cup thinly sliced onion
- 1 tablespoon butter
- Garlic and herb seasoning to taste

Combine carrots, squash, zucchini, bell pepper, and onion in a 2 quart microwave safe casserole dish. Dot with butter and sprinkle with seasoning. Cover, and microwave on High power for 8 minutes or to desired degree of doneness.

Lemon and Shrimp Risotto

- 2 teaspoons butter
- 2 teaspoons olive oil
- 2 tablespoons finely chopped shallot
- 4 cups chicken broth
- ¼ cup fresh squeezed lemon juice
- 2 cups risotto
- 1 pound medium shrimp, peeled and deveined
- 1 cup frozen peas, thawed
- 2 teaspoons grated lemon zest
- ¼ teaspoon black pepper
- ¾ teaspoon salt

Combine butter, olive oil, and shallot in a 1 quart microwave safe dish. Microwave on High for 1 minute or until shallot is tender. Set aside.

Combine chicken broth and lemon juice in a 2 quart microwave safe measuring cup or casserole dish. Cover with lid or vented plastic wrap. Microwave on High power for 10 minutes. Stir in reserved shallot mixture and risotto. Cover and continue to microwave on 50% power for 20 minutes.

Stir in shrimp, peas, grated lemon zest, pepper, and salt. Cover and microwave on 50% power for 5 minutes or until shrimp is opaque.

White Chicken Chili

- 1 pound boneless, skinless chicken breast, cubed
- ½ cup chopped onion
- 3 garlic cloves, minced
- 1 (15 ounce) can white beans, drained
- 1 (4 ounce) can chopped green chili pepper

- 1 cup chicken broth
- 1 ½ teaspoon chili powder
- ¾ teaspoon cumin
- ½ teaspoon salt
- ½ teaspoon black pepper
- ½ cup chopped fresh cilantro
- 2 tablespoons fresh lime juice

Combine chicken, onion, and garlic in a 2.5 quart microwave safe dish. Cover, and microwave on High for 6 minutes, or until chicken is fully cooked and onion is tender, stirring after 3 minutes.

Add white beans, chili pepper, chicken broth, chili powder, cumin, salt and pepper, stirring well. Cover and microwave on High for 10 minutes, stirring after 5 minutes.

Stir in cilantro and lime juice before serving.

AUTO DEFROST

Using Auto Defrost

The auto defrost feature provides you with the best defrosting method for frozen foods. The cooking guide will show you which defrost sequence is recommended for the food you are defrosting.

For added convenience, the Auto Defrost includes a built-in beep mechanism that reminds you to check, turn over, separate, or rearrange the food in order to get the best defrost results. Three different defrosting levels are provided:

1. **MEAT**
2. **POULTRY**
3. **FISH**

Available weight is 0.1-6.0 lbs

- Suppose you want to defrost 1.2 lbs of fish.

Touch:**Display Shows:**

1. **Auto
Defrost**

PRESS AGAIN FOR OPTIONS/ PRESS START

MEAT

2. **Auto
Defrost**

PRESS AGAIN FOR OPTIONS/ PRESS START

POULTRY

3. **Auto
Defrost**

PRESS AGAIN FOR OPTIONS/ PRESS START

FISH

4. **START
+30 Sec**

ENTER WEIGHT

lb

5. (1) and (2)

PRESS START

1.2

lb

To enter weight

6. **START
+30 Sec**

DEFR.

FISH

Time counting down

NOTES: The oven will beep during the DEFROST cycle. At this time, open the door and turn, separate, or rearrange the food. Remove any portions that have thawed. Return frozen portions to

the oven and touch **START +30 Sec** to resume the defrost cycle.

Operating Tips

- For best results, remove fish, shell fish, meat and poultry from its original closed paper or plastic package (wrapper). Otherwise, the wrap will hold steam and juice close to the foods, which can cause the outer surface of the foods to cook.

- For best results, roll your ground meat into a ball before freezing. During the DEFROST cycle, the microwave will signal when it is time to turn the meat over. Scrape off any excess frost from the meat and continue defrosting.
- Place foods in a shallow container or on a microwave roasting rack to catch drippings.

This table shows food type selections and the weights you can set for each type. For best results, loosen or remove covering on food.

KEY PRESS	Category	WEIGHTS YOU CAN SET (tenths of a pound)
Auto Defrost x 1	Meat	0.1 to 6.0
Auto Defrost x 2	Poultry	0.1 to 6.0
Auto Defrost x 3	Fish	0.1 to 6.0

Weight conversion table

You are probably used to measuring food in pounds and ounces that are fractions of a pound (for example, 4 ounces equals 1/4 pound). However, in order to enter food weight in Auto Defrost, you must specify pounds and tenths of a pound.

If the weight on the food package is in fractions of a pound, you can use the following table to convert the weight to decimals.

Equivalent Weight	
OUNCES	DECIMAL WEIGHT
1.6	.10
3.2	.20
4.0	.25 One-Quarter Pound
4.8	.30
6.4	.40
8.0	.50 One-Half Pound
9.6	.60
11.2	.70
12.0	.75 Three-Quarters Pound
12.8	.80
14.4	.90
16.0	1.0 One Pound

NOTES: If between two decimal weights, choose the lower weight for the best defrosting results.

Auto Defrost Table

NOTE: Meat of irregular shape and large, fatty cuts of meat should have the narrow or fatty areas shielded with foil at the beginning of the defrost sequence.

Meat Settings

FOOD	SETTING	AT BEEP	SPECIAL INSTRUCTIONS
BEEF			
Ground Beef, Bulk	MEAT	Remove thawed portions with fork. Turn over. Return remainder to oven.	Do not defrost less than 1/4 lb. Freeze in ball shape.
Ground Beef, Patties	MEAT	Separate and rearrange.	Do not defrost less than 2 oz. patties. Depress center when freezing.
Round Steak	MEAT	Turn over. Cover warm areas with aluminum foil.	Place in a microwave safe dish.
Tenderloin Steak	MEAT	Turn over. Cover warm areas with aluminum foil.	Place in a microwave safe dish.
Stew Beef	MEAT	Remove thawed portions with fork. Separate remainder.	Place in a microwave safe dish.
Pot Roast, Chuck Roast	MEAT	Return remainder to oven.	Place in a microwave safe dish.
Rib Roast	MEAT	Turn over. Cover warm areas with aluminum foil.	Place in a microwave safe dish.
Rolled Rump Roast	MEAT	Turn over. Cover warm areas with aluminum foil.	Place in a microwave safe dish.
LAMB			
Cubes for Stew	MEAT	Turn over. Cover warm areas with aluminum foil.	Place in a microwave safe dish.
Chops (1 inch thick)	MEAT	Remove thawed portions with fork. Return remainder to oven.	Place in a microwave safe dish.
PORK			
Chops (1/2 inch thick)	MEAT	Separate and rearrange.	Place in a microwave safe dish.
Hot Dogs	MEAT	Separate and rearrange.	Place in a microwave safe dish.
Spareribs Country-style Ribs	MEAT	Turn over. Cover warm areas with aluminum foil.	Place in a microwave safe dish.
Sausage, Links	MEAT	Separate and rearrange.	Place in a microwave safe dish.
Sausage, Bulk	MEAT	Remove thawed portions with fork. Turn over. Return remainder to oven.	Place in a microwave safe dish.
Loin Roast, Boneless	MEAT	Turn over. Cover warm areas with aluminum foil.	Place in a microwave safe dish.

Poultry Settings

FOOD	SETTING	AT BEEP	SPECIAL INSTRUCTIONS
CHICKEN Whole (up to 6 lbs) Cut-up	POULTRY	Turn over breast side down. Cover warm areas with aluminum foil. Separate pieces and rearrange. Turn over. Cover warm areas with aluminum foil.	Place chicken breast-side up in a microwave safe dish. Finish defrosting by immersing in cold water. Remove giblets when chicken is partially defrosted. Place in a microwave safe dish. Finish defrosting by immersing in cold water.
CORNISH HENS Whole	POULTRY	Turn over. Cover warm areas with aluminum foil.	Place in a microwave safe dish. Finish defrosting by immersing in cold water.
TURKEY Breast (up to 6 lbs)	POULTRY	Turn over. Cover warm areas with aluminum foil.	Place in a microwave safe dish. Finish defrosting by immersing in cold water.

Fish Settings

FOOD	SETTING	AT BEEP	SPECIAL INSTRUCTIONS
FISH Fillets	FISH	Turn over. Separate fillets when partially thawed, if possible.	Place in a microwave safe dish. Carefully separate fillets under cold water.
Steaks	FISH	Separate and rearrange.	Place in a microwave safe dish. Run cold water over to finish defrosting.
Whole	FISH	Turn over	Place in a microwave safe dish. Cover head and tail with foil; do not let foil touch sides of microwave. Finish defrosting by immersing in cold water.
SHELLFISH			
Crab meat	FISH	Break apart. Turn over.	Place in a microwave safe dish.
Lobster tails	FISH	Turn over and rearrange.	Place in a microwave safe dish.
Shrimp	FISH	Separate and rearrange.	Place in a microwave safe dish.
Scallops	FISH	Separate and rearrange.	Place in a microwave safe dish.

Defrosting Tips

- When using Auto Defrost, the weight to be entered is the net weight in pounds and tenths of pounds (the weight of the food minus the container).
- Before starting, make sure to remove any and all metal twist-ties that often come with frozen food bags, and replace them with strings or elastic bands.
- Open containers, such as cartons, before placing in the oven.
- Always slit or pierce plastic pouches or packaging.
- If food is foil wrapped, remove foil and place food in a suitable container.

- Slit the skin of skinned food, such as sausage.
- Bend plastic pouches of food to ensure even defrosting.
- Always underestimate defrosting time. If defrosted food is still icy in the center, return it to the microwave oven for more defrosting.
- The length of defrosting time varies according to how solidly the food is frozen.
- The shape of the package affects how quickly food will defrost. Shallow packages will defrost more quickly than a deep block.
- As food begins to defrost, separate the pieces. Separated pieces defrost more easily.
- Use small pieces of aluminum foil to shield parts of food such as chicken wings, leg tips, fish tails, or areas that start to get warm. Make sure the foil does not touch the sides, top, or bottom of the oven. The foil can damage the oven lining.
- For better results, let food stand after defrosting.
- Turn over food during defrosting or standing time. Break apart and remove food as required.

CONVENIENT FEATURES

Clock & Settings

The microwave oven has settings that allow you to customize the operation for your convenience. Below is the table showing the various settings. Touch the Clock & Settings key multiple times to scroll to the desired setting function.

Key press	Option
Clock & Settings x1	Clock
Clock & Settings x2	Control Lock
Clock & Settings x3	Power Save
Clock & Settings x4	Volume Low/Med/High/Off
Clock & Settings x5	Pure Air Filter Reset/Off
Clock & Settings x6	Language
Clock & Settings x7	Weight lb/kg
Clock & Settings x8	Demo

Setting Clock

The clock can be disabled when the microwave is first plugged in and the **STOP** Clear key is selected. To re-enable the clock follow clock instructions.

- Suppose you want to set the clock for 10:59.

Touch:	Display Shows:
1. Clock & Settings	<small>PRESS AGAIN FOR OPTIONS/</small>
2. (1) (0) (5) (9)	<small>PRESS START</small>
3. START +30 Sec	

NOTE

1. If you begin to enter in an incorrect time (e.g. 2:89) the 8 is an invalid digit and cannot be entered. Enter the correct time.
2. **STOP**
If you touch **Clear** while setting the clock, the display will show the last time of day set or a blank display if no time of day has been set.

Setting Control Lock On/Off

To turn ON Control Lock .

Touch:

Display Shows:

1. **Clock &
Settings**

PRESS AGAIN FOR OPTIONS/
12:00 ENTER TIME

2. **Clock &
Settings**

PRESS AGAIN FOR OPTIONS/ PRESS START
CONTROL LOCK

3. **START
+30 Sec**

**Time of day
if time of day was set
LOCK**

To turn OFF the Control Lock, touch **Clock &
Settings**
then touch **START
+30 Sec**

Setting Power Save On/Off

To turn ON Power Save. Turning ON power save turns off the time of day clock display.

Touch:

Display Shows:

1. Clock &
Settings

PRESS AGAIN FOR OPTIONS/
12:00 ENTER TIME

2. Clock &
Settings

PRESS AGAIN FOR OPTIONS/ PRESS START
CONTROL LOCK

3. Clock &
Settings

PRESS AGAIN FOR OPTIONS/ PRESS START
POWER SAVE OFF

4. START
+30 Sec

ON

To turn OFF the Power Save, touch **Clock & Settings** and choose POWER SAVE, select OFF then touch ^{START}+30 Sec.

Turning Sound Low/Med/High/Off

Audible signals are available to guide you when setting and using your oven.

- A **programming tone** will sound each time you touch a pad.
- **Three tones** signal the end of a Kitchen Timer count down.
- **Three tones** signal the end of a cooking cycle.

Suppose you want to turn audible signal off.

Touch:

Display Shows:

1. Clock &
Settings

PRESS AGAIN FOR OPTIONS/
12:00 ENTER TIME

2. Clock &
Settings

PRESS AGAIN FOR OPTIONS/ PRESS START
CONTROL LOCK

3. Clock &
Settings

PRESS AGAIN FOR OPTIONS/ PRESS START
POWER SAVE OFF

4. Clock &
Settings

PRESS AGAIN FOR OPTIONS/ PRESS START
VOLUME LOW

PRESS AGAIN FOR OPTIONS/ PRESS START
VOLUME MED

PRESS AGAIN FOR OPTIONS/ PRESS START
VOLUME HIGH

PRESS AGAIN FOR OPTIONS/ PRESS START
VOLUME OFF

5. START
+30 Sec

OFF

NOTE: When the cooking cycle is completed END will be displayed and the audible signal will sound if the sound is turned on.

SETTING FILTER RESET OR FILTER OFF

- Suppose you want to set the filter reset to off.

Touch:	Display Shows:
1. Clock & Settings	<small>PRESS AGAIN FOR OPTIONS/</small> 12:00 ENTER TIME
2. Clock & Settings	<small>PRESS AGAIN FOR OPTIONS/ PRESS START</small> CONTROL LOCK
3. Clock & Settings	<small>PRESS AGAIN FOR OPTIONS/ PRESS START</small> POWER SAVE OFF
4. Clock & Settings	<small>PRESS AGAIN FOR OPTIONS/ PRESS START</small> VOLUME LOW
5. Clock & Settings	<small>PRESS AGAIN FOR OPTIONS/ PRESS START</small> PURE AIR FILTER RESET
	<small>PRESS AGAIN FOR OPTIONS/ PRESS START</small> PURE AIR FILTER OFF
6. START +30 Sec	OFF

NOTE: Select FILTER RESET to turn off “FILTER” icon and reset to remind in 6 months; if you want to turn off “FILTER” icon notification and not remind at all, select FILTER OFF and press

START
+30 Sec

SETTING LANGUAGE ENGLISH/FRANCAIS

- Suppose you want to set the language.

Touch:	Display Shows:
1. Clock & Settings	<small>PRESS AGAIN FOR OPTIONS/</small> 12:00 ENTER TIME
2. Clock & Settings	<small>PRESS AGAIN FOR OPTIONS/ PRESS START</small> CONTROL LOCK
3. Clock & Settings	<small>PRESS AGAIN FOR OPTIONS/ PRESS START</small> POWER SAVE OFF
4. Clock & Settings	<small>PRESS AGAIN FOR OPTIONS/ PRESS START</small> VOLUME LOW
5. Clock & Settings	<small>PRESS AGAIN FOR OPTIONS/ PRESS START</small> PURE AIR FILTER RESET
6. Clock & Settings	<small>PRESS AGAIN FOR OPTIONS/ PRESS START</small> LANGUAGE FRENCH
7. START +30 Sec	FRANCAIS

START

NOTE: When **+30 Sec** is pressed and the previous setting was English it will be set to French. If you want switch back to English you will have to again press **Clock & Settings** five times and then

START

press **+30 Sec**.

Setting Weight Lb/Kg

- Suppose you want to toggle weight between pounds & kilograms.

Touch:

Display Shows:

1. Clock &
Settings

PRESS AGAIN FOR OPTIONS/
12:00 ENTER TIME

2. Clock &
Settings

PRESS AGAIN FOR OPTIONS/ PRESS START
CONTROL LOCK

3. Clock &
Settings

PRESS AGAIN FOR OPTIONS/ PRESS START
POWER SAVE OFF

4. Clock &
Settings

PRESS AGAIN FOR OPTIONS/ PRESS START
VOLUME LOW

5. Clock &
Settings

PRESS AGAIN FOR OPTIONS/ PRESS START
PURE AIR
FILTER RESET

6. Clock &
Settings

PRESS AGAIN FOR OPTIONS/ PRESS START
LANGUAGE FRANCH

7. Clock &
Settings

PRESS AGAIN FOR OPTIONS/ PRESS START
Lb / Kg

8. START
+30 Sec

NOTE: If the display shows kg, pressing the **START +30 Sec** button will reset the oven controls to lbs. To return to kg, you will have to again press **Clock & Settings** six times and then press **START +30 Sec**.

Setting Demo Mode On/Of

- Suppose you want to enter Demo mode. When Demo mode is ON programming functions will work in a rapid countdown mode with no cooking power.



Touch:

Display Shows:

1. Clock &
Settings

PRESS AGAIN FOR OPTIONS/
12:00 ENTER TIME

2. Clock &
Settings

PRESS AGAIN FOR OPTIONS/ PRESS START
CONTROL LOCK

3. Clock &
Settings

PRESS AGAIN FOR OPTIONS/ PRESS START
POWER SAVE OFF

4. Clock &
Settings

PRESS AGAIN FOR OPTIONS/ PRESS START
VOLUME LOW

5. Clock &
Settings

PRESS AGAIN FOR OPTIONS/ PRESS START
PURE AIR
FILTER RESET

6. Clock &
Settings

PRESS AGAIN FOR OPTIONS/ PRESS START
LANGUAGE FRANCH

7. Clock &
Settings

PRESS AGAIN FOR OPTIONS/ PRESS START
LB / KG

8. Clock &
Settings

PRESS AGAIN FOR OPTIONS/ PRESS START
DEMO OFF

9. START
+30 Sec

ON

NOTE: When **START +30 Sec** is pressed and the previous setting was OFF then it will be set to ON. If you want to turn the demo mode back OFF you will have to again press Clock & **Settings** seven times and then press **START +30 Sec**.

Setting Kitchen Timer

Your microwave oven can be used as a kitchen timer. You can set up to 99 minutes, 99 seconds. The kitchen timer can be used while the microwave oven is running.

- Suppose you want to set for three minutes.

Touch:	Display Shows:
1. Timer On-Off	TIMER ENTER TIME
2. 3 0 0	TIMER 3:00 <small>PRESS START</small>
3. Timer On-Off	TIMER 3:00 Timer starts counting down

NOTE: Timer count down does not stop even if the door is open. When timer and cooking both are working, press " Timer On-Off " once, the display would show the remaining timer; to cancel the timer, press " Timer On-Off " once again. When only timer working, press " Timer On-Off " once to cancel the timer.

Using Vent Fan

The pad controls the 2-speed vent fan. If the vent fan is OFF the first touch of the Vent pad will turn the fan on HIGH, second touch LOW and third touch OFF.

- Suppose you want to set the vent fan speed to LOW from the OFF position.

Touch:	Display Shows:
--------	----------------

1.  Hi Low Off	HIGH
--	------

2.  Hi Low Off	LOW
--	-----

NOTE: If the temperature from the range or cooktop below the oven gets too hot, the vent fan will automatically turn on to protect the oven. It may stay on up to an hour to cool the oven. When this occurs, the Vent pad will not turn the fan off.

Using Cooktop Light

The pad controls the cooktop light. If the light is OFF the first touch of the light pad will turn the light ON (high), second touch Nite (low) and third touch OFF.

- Suppose you want to set the light for HIGH from the OFF position.

Touch:	Display Shows:
--------	----------------

1.  Hi Low Off	HIGH
--	------

Setting Turntable On/Off

Press Turntable On-Off to turn the turntable on or off.

For best cooking results, leave the turntable on. It can be turned off for large dishes.

Touch:

Display Shows:**1. Turntable
On-Off****OFF****2. Turntable
On-Off****ON**

NOTE: Sometimes the turntable can become hot to the touch during and after cooking. Do not run the oven empty without food in it.

CLEANING AND CARE

Disconnect the power cord or leave the door open to deactivate the oven during cleaning. Disconnect the power cord before replacing filters and lights.

EXTERIOR

The outside surface is precoated steel and plastic. Clean the outside with mild soap and water; rinse and dry with a soft cloth. Do not use any type of household or abrasive cleaner.

DOOR

Wipe the window on both sides with a soft cloth to remove any spills or splatters. Metal parts will be easier to maintain if wiped frequently with a soft cloth. Avoid the use of spray and other harsh cleaners as they may stain, streak or dull the door surface.

EASY CARE™ STAINLESS STEEL / SMUDGE _ PROOF™ STAINLESS STEEL / BLACK STAINLESS STEEL (SOME MODELS)

Your microwave oven(some models) may have a Stainless Steel finish or coating. Clean the stainless with warm soapy water using a clean sponge or cloth. Rinse with clean water and dry with a soft clean cloth. DO NOT use ANY store bought cleaners like Stainless Steel cleaners or any other types of cleaners containing any abrasive, chlorides, chlorines or ammonia. It is recommended to use mild dish soap and water or a 50/50 solution of water and vinegar.

TOUCH CONTROL PANEL

Care should be taken in cleaning the touch control panel. If the control panel becomes soiled, open the microwave oven door before cleaning. Wipe the panel with a cloth dampened slightly with water only. Dry with a soft cloth. Do not scrub or use any sort of chemical cleaners. Close door and touch STOP/CLEAR.

INTERIOR

Cleaning is easy because little heat is generated to the interior surfaces . To clean the interior surfaces, wipe with a soft cloth and warm water. **DO NOT USE ABRASIVE OR HARSH CLEANERS OR SCOURING PADS.** For heavier soil, use baking soda or a mild soap; rinse thoroughly with hot water. The round wire rack and shelf can be cleaned with hot soapy water, rinsed and dried.

WAVEGUIDE COVER

The waveguide cover is located on the right side in the microwave oven cavity. It is made from mica so requires special care. Keep the waveguide cover clean to assure good microwave oven performance. Carefully wipe with a damp cloth any food spatters from the surface of the cover immediately after they occur. Built-up splashes may overheat and cause smoke or possibly catch fire. **DO NOT REMOVE THE WAVEGUIDE COVER.**

ODOR REMOVAL

Occasionally, a cooking odor may remain in the microwave oven. To remove, combine 1 cup water, grated peel and juice of 1 lemon in a 2-cup glass measuring cup. Boil for several minutes using 100% power.

Allow to set in microwave oven until cool. Wipe interior with a soft cloth.

TURNTABLE/TURNTABLE SUPPORT

The turntable and turntable support can be removed for easy cleaning. Wash them in mild, sudsy water; for stubborn stains use a mild cleanser and non-abrasive scouring sponge. They are also dishwasher-proof. Use upper wirerack of dishwasher. The turntable motor shaft is not sealed, so excess water or spills should be wiped up immediately.

Cleaning the exhaust filters

The oven ventilation exhaust filters should be removed and cleaned often; generally at least once every month.

Vent exhaust filter part number 5304478913 To order parts call 800-599-7569

CAUTION: To avoid risk of personal injury or property damage, do not operate oven hood without filters properly in place.

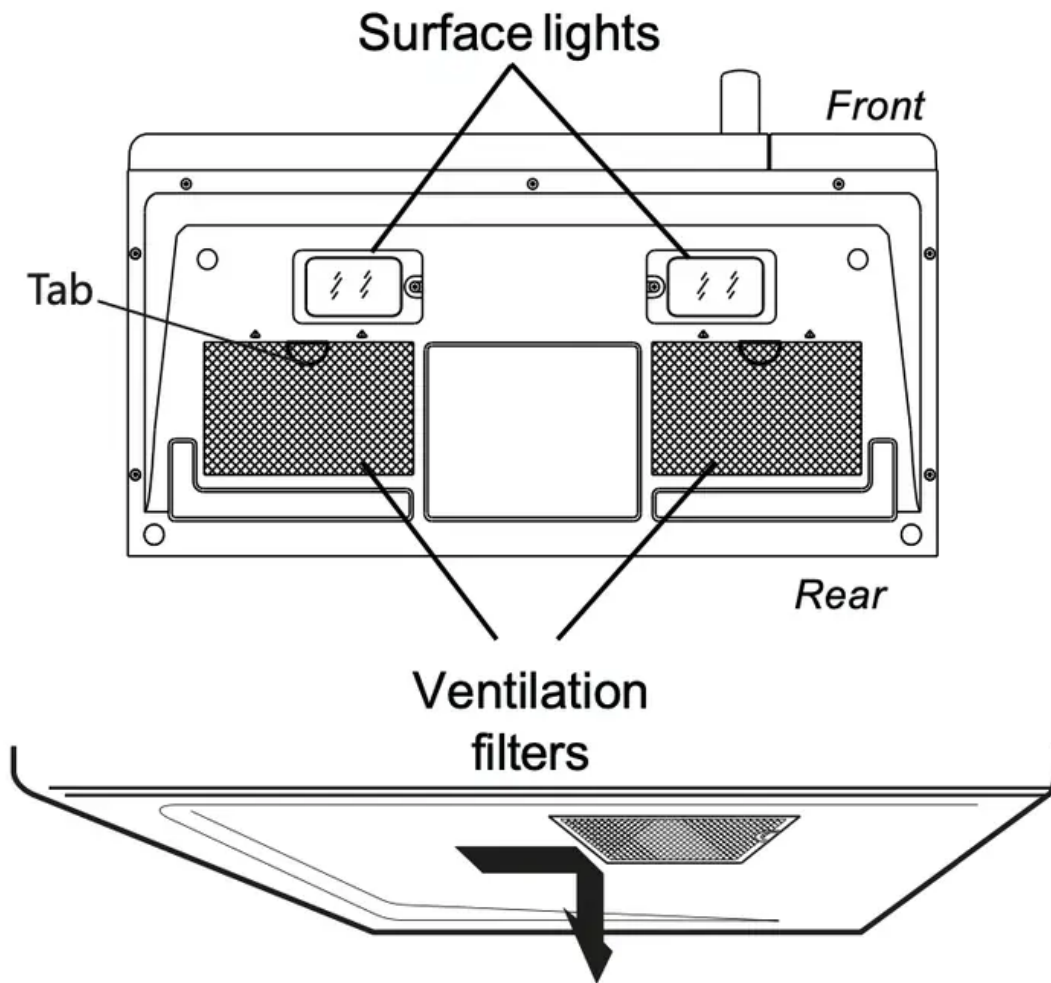

1. To remove the exhaust ventilation filters, slide the filter to the rear. Then pull filter downward and push to the other side. The filter will drop out. Repeat for the 2nd filter.

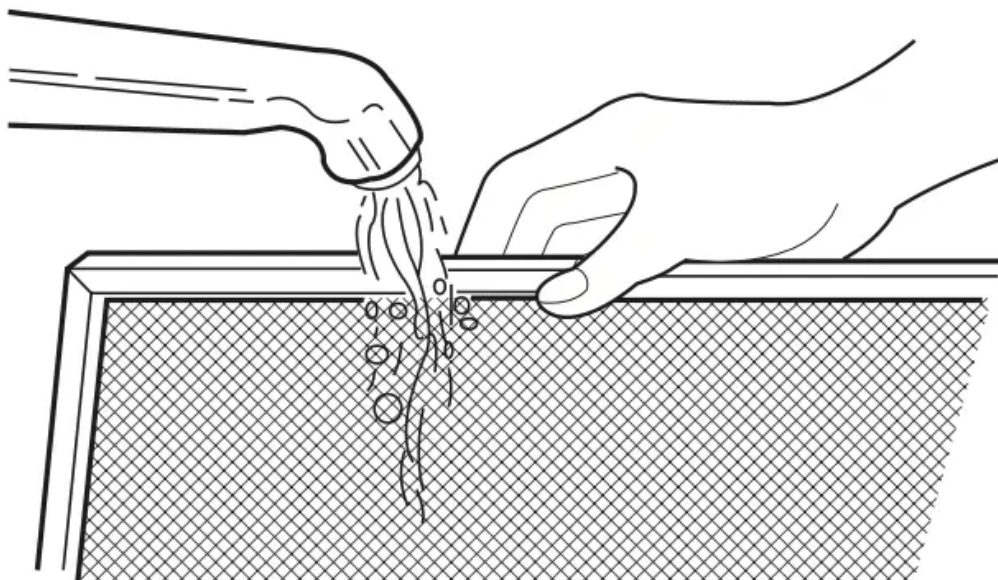

2. Soak the ventilation filters in hot water using a mild detergent. Rinse well and shake to dry or wash in a dishwasher. Do not use ammonia. The aluminum on the filter will

corrode and darken.

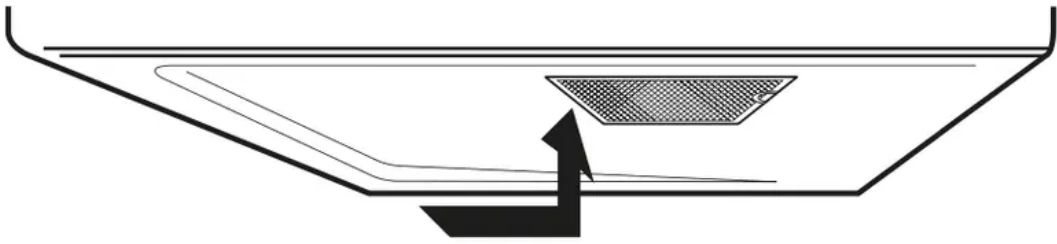

3. To reinstall the exhaust ventilation filter, slide it into the side slot, then push up and toward oven to lock. Reinstall the 2nd filter using the same procedure.

Surface light replacement

CAUTION: To avoid risk of personal injury or property damage, wear gloves when replacing the light bulbs.

1. Unplug the microwave oven or turn off power at the main circuit breaker.
2. Remove the LED light cover mounting screws at both light positions under the microwave.

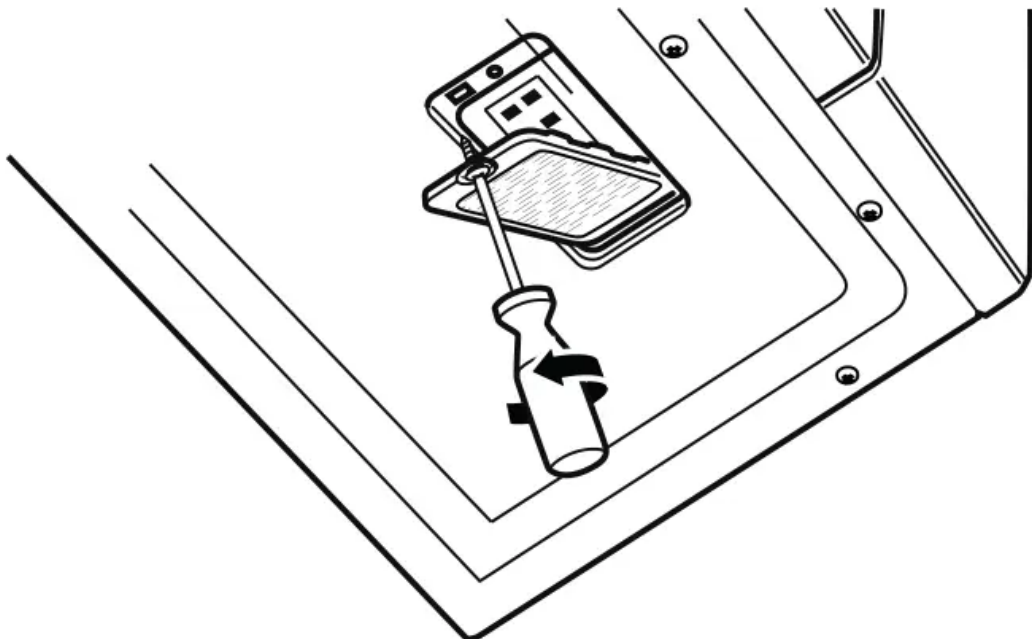

3. Remove the LED light mounting screw.

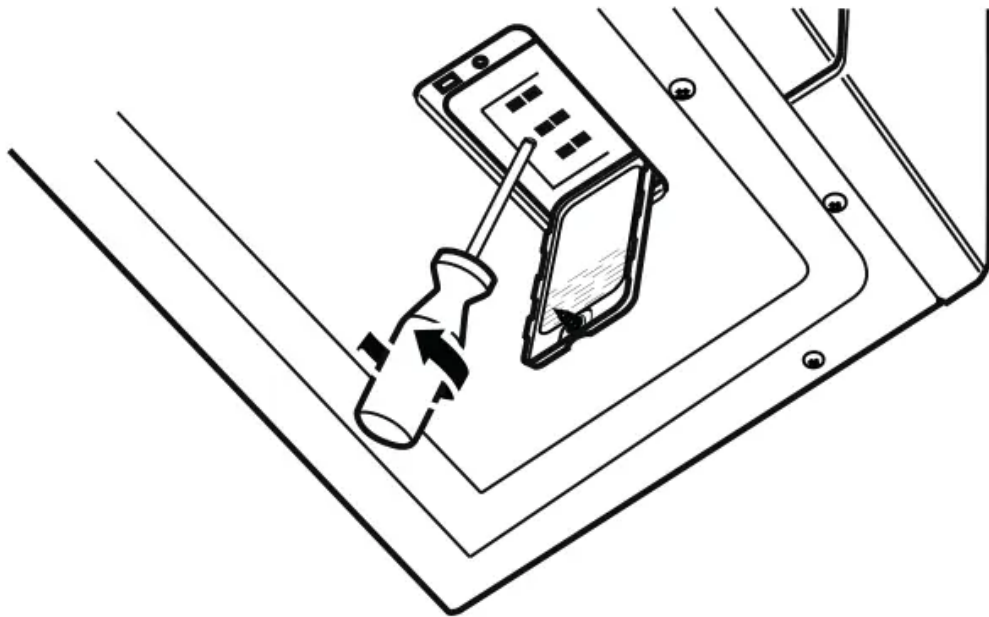

4. Unplug the LED light from the harness, replace with LED light of part### # # 5304499540.
To order parts call 800-599 - 7569. Then reconnect the harness.

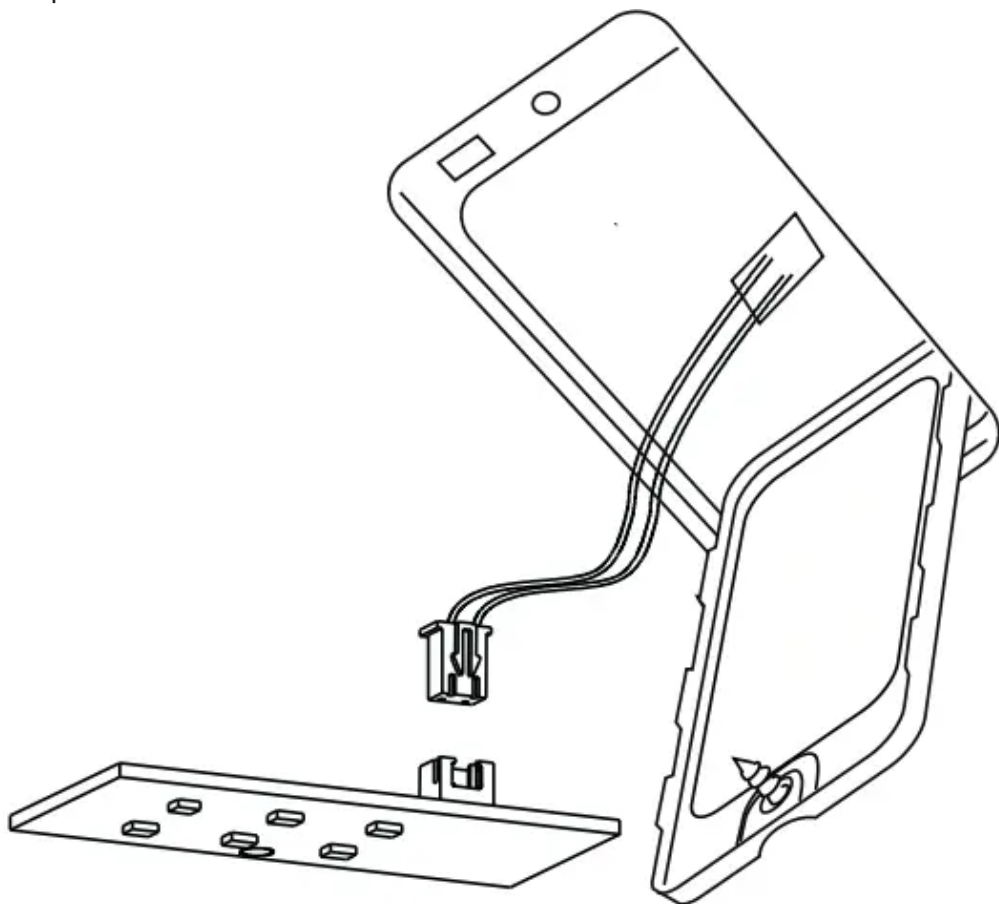

5. Re-install LED light and mounting screw.

When re-installing mounting screw be careful not to damage the LED light.

6. Re-install LED light cover and mounting screw.

7. Plug the microwave back into the power supply or turn the power back on at the main circuit breaker.

PureAir Microwave Filter replacement

For replacement filters visit Frigidaire.com or call 1 800 599 7569 and ask for OTRFILTER1.

PureAir® Filter Replacement Part Number: OTRFILTER1 Replace filter every 6 months.

The PureAir® Microwave Filter, when used with the recirculation fan, reduces cooking odors from your cooktop surface by trapping, neutralizing and removing odor-causing molecules. The proprietary activated carbon is 10 times more effective at reducing cooking odors than standard charcoal filters. For best results, replace every 6 months.

1. Remove the PureAir® filter from the packaging and shake filter to remove excess carbon.
2. Use a Phillips head screwdriver to unscrew the PureAir® Filter access door.
3. Open the filter access door.

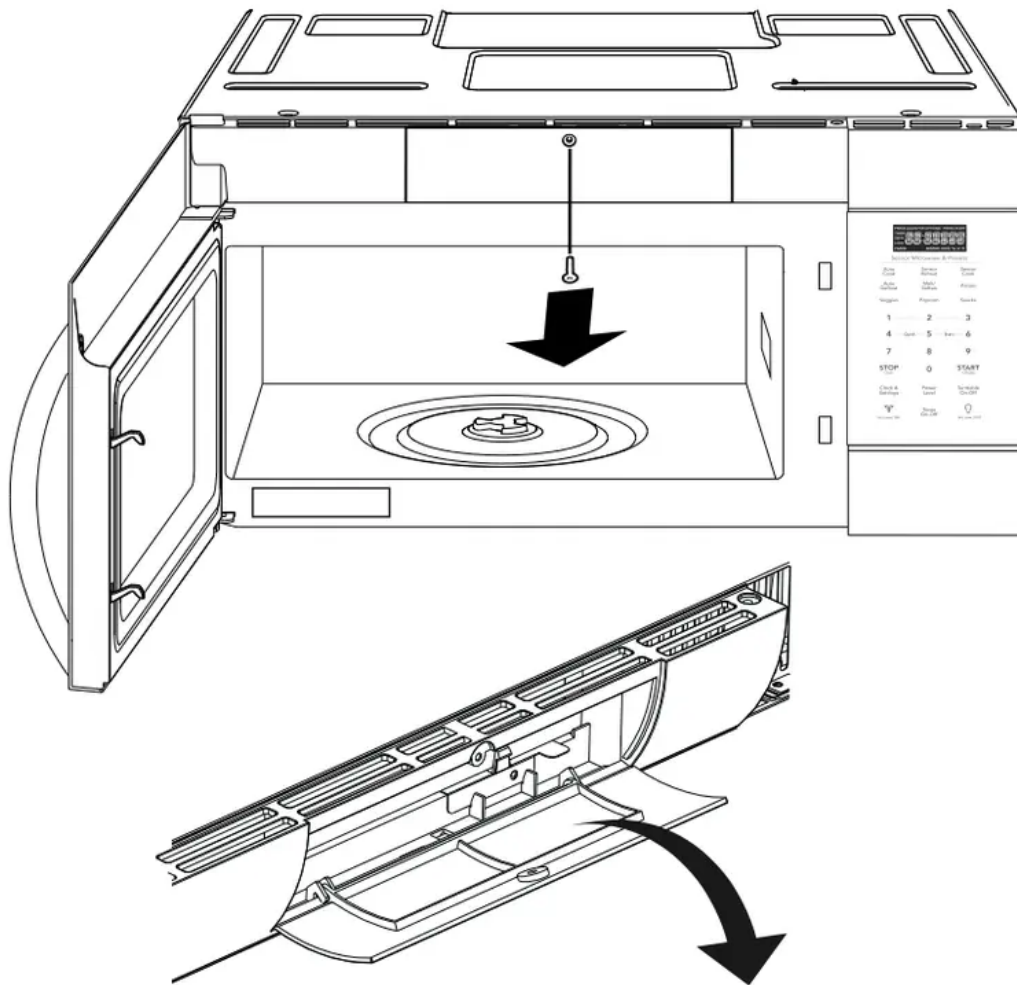

4. Remove the existing PureAir® filter (if installed) by pulling forward out from the unit.

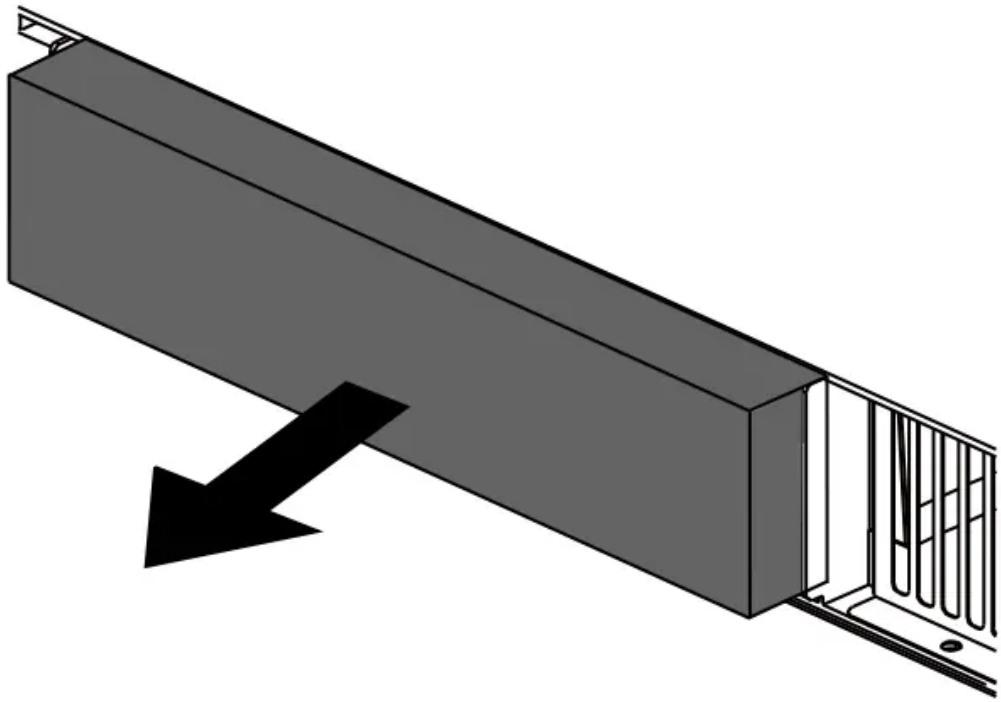

5. Place the new PureAir® filter into the slot behind the door at an angle until it's upright and securely placed in the duct.

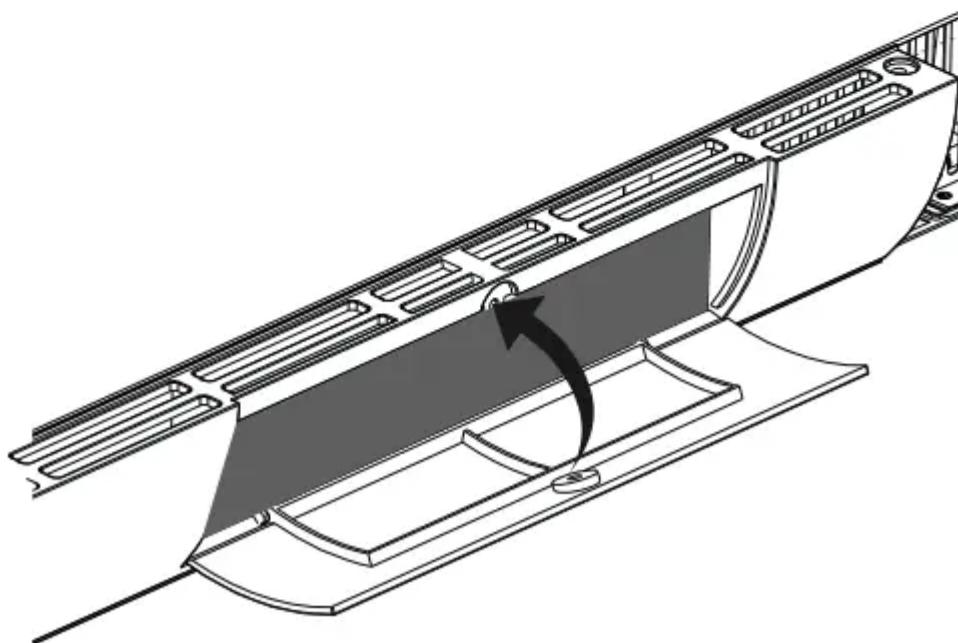
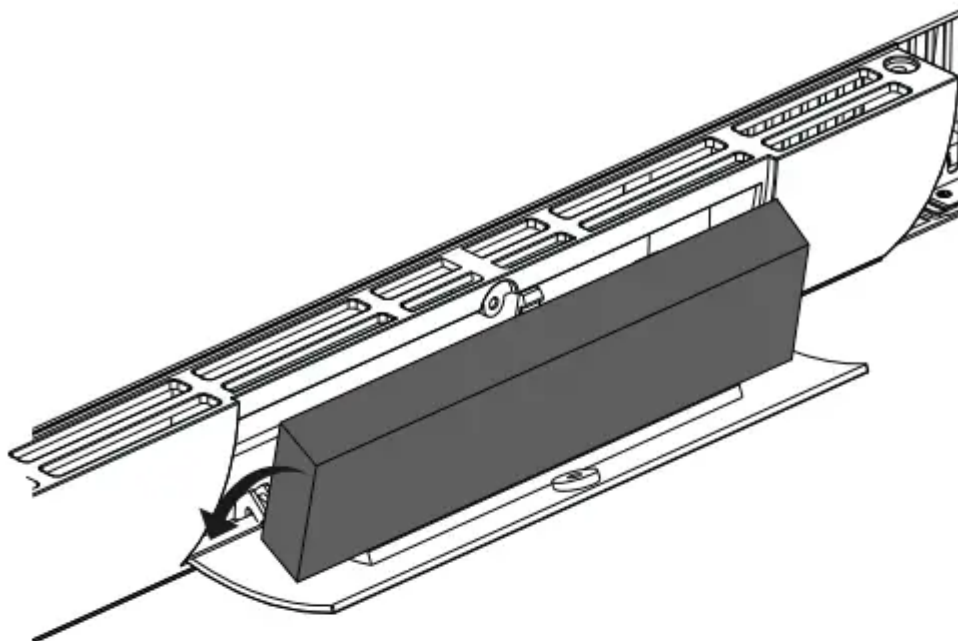

6. Make sure the PureAir® filter is nested vertically in the slot. Close access door, tighten screw and the PureAir® filter is ready to use.

Oven light replacement

To access the light cover remove the PureAir®

Microwave Carbon Filter per instructions 1-4 above in the PureAir® Microwave Carbon Filter replacement section.

1. Open light cover located behind PureAir® Microwave Carbon Filter by carefully pulling up on the front edge.

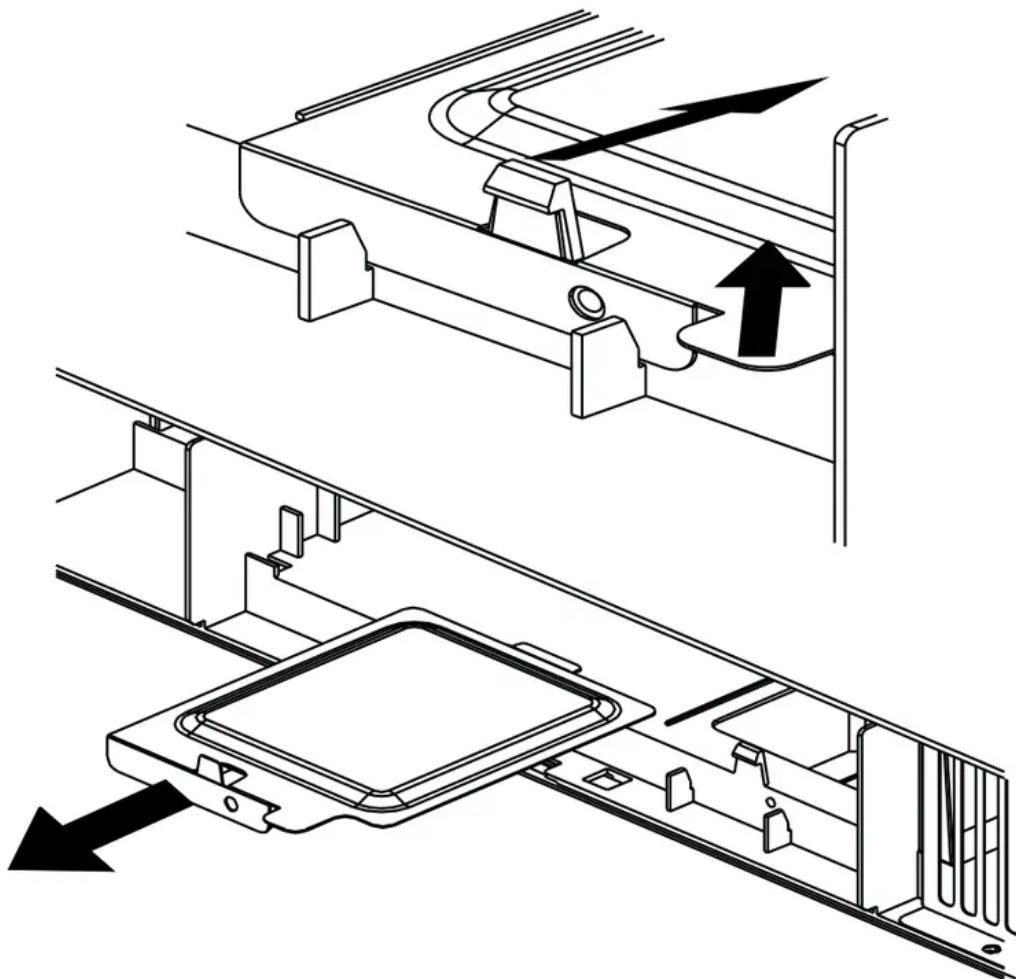

2. Remove the LED bracket and light assembly. Remove the LED light from the bracket by removing the mounting screw and replace only with part 5304499540. To order parts call

800-599-7569.

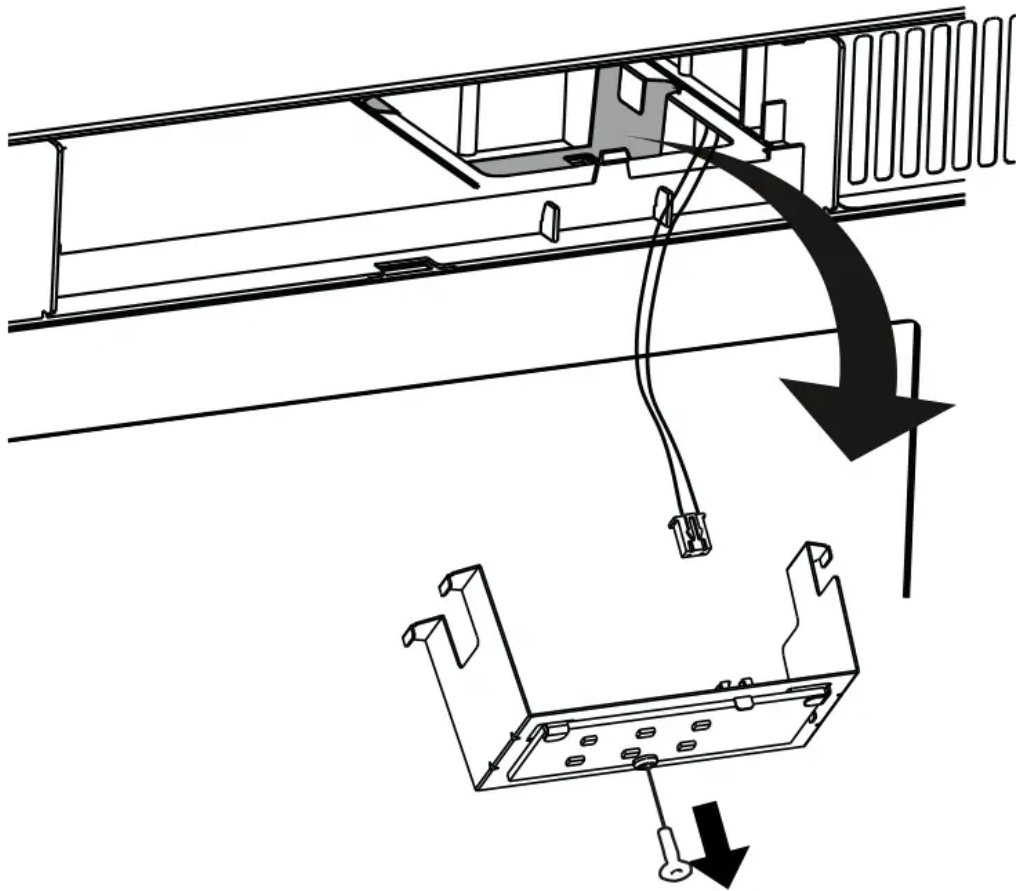

3. Re-install LED light to the bracket with mounting screw. When re-installing mounting screw be careful not to damage the LED light.

4. Reconnect LED light to the harness and place the LED light assembly back into the plastic housing.

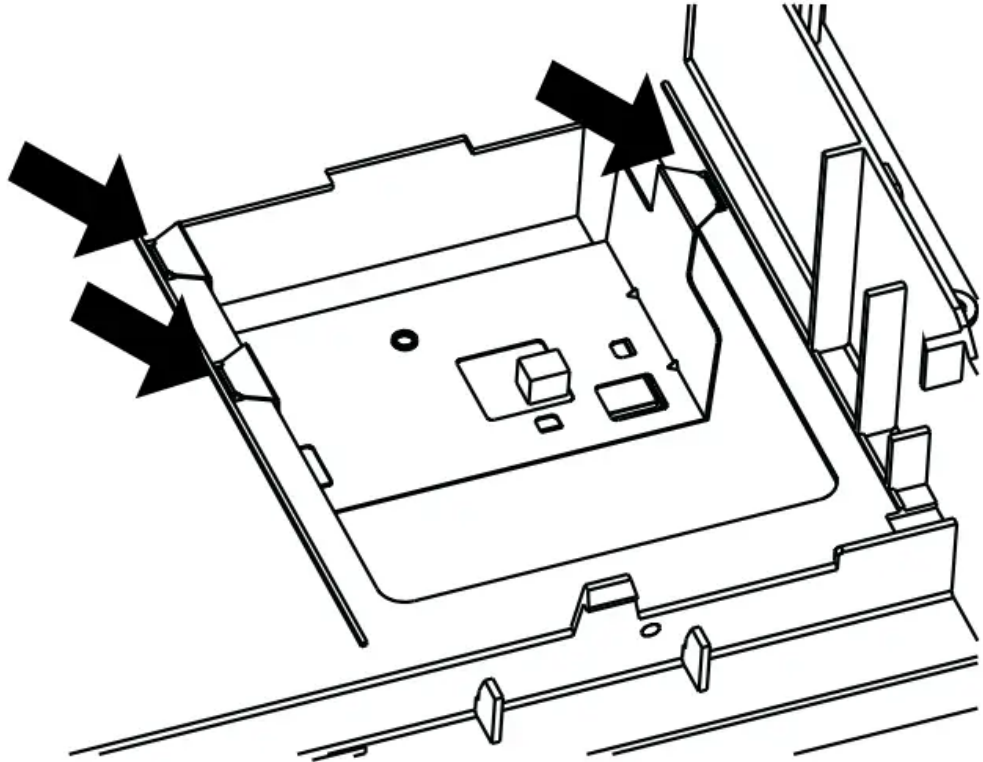

5. Replace the microwave oven light cover by carefully pushing into place (make sure the light cover rear tab is inserted into slot at rear).

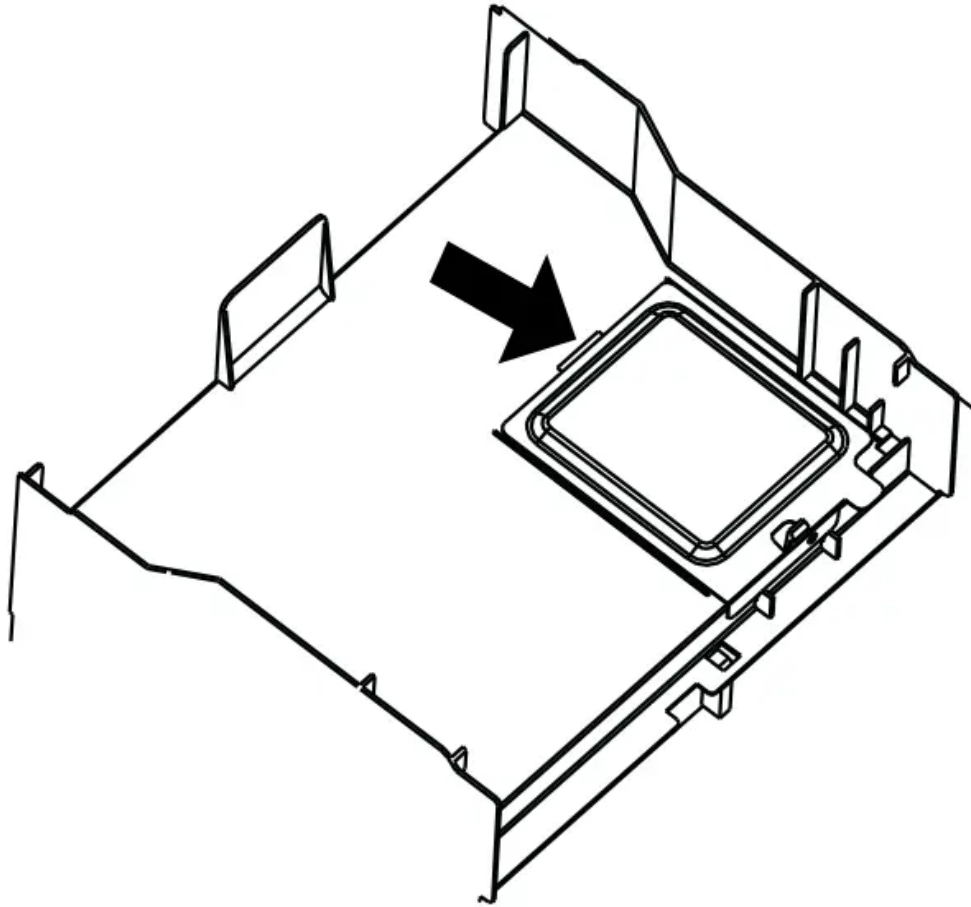

6. Replace the PureAir® Microwave Carbon Filter . Close the vent grille door and tighten the vent grill door mounting screw.

Warning

This content is compiled from multiple sources and is provided for reference purposes only. It may not be complete or fully applicable to all situations. If you are unable to resolve your issue, please contact the product manufacturer or an authorized service provider for official support.