

## PREPARATION

### Remote Control

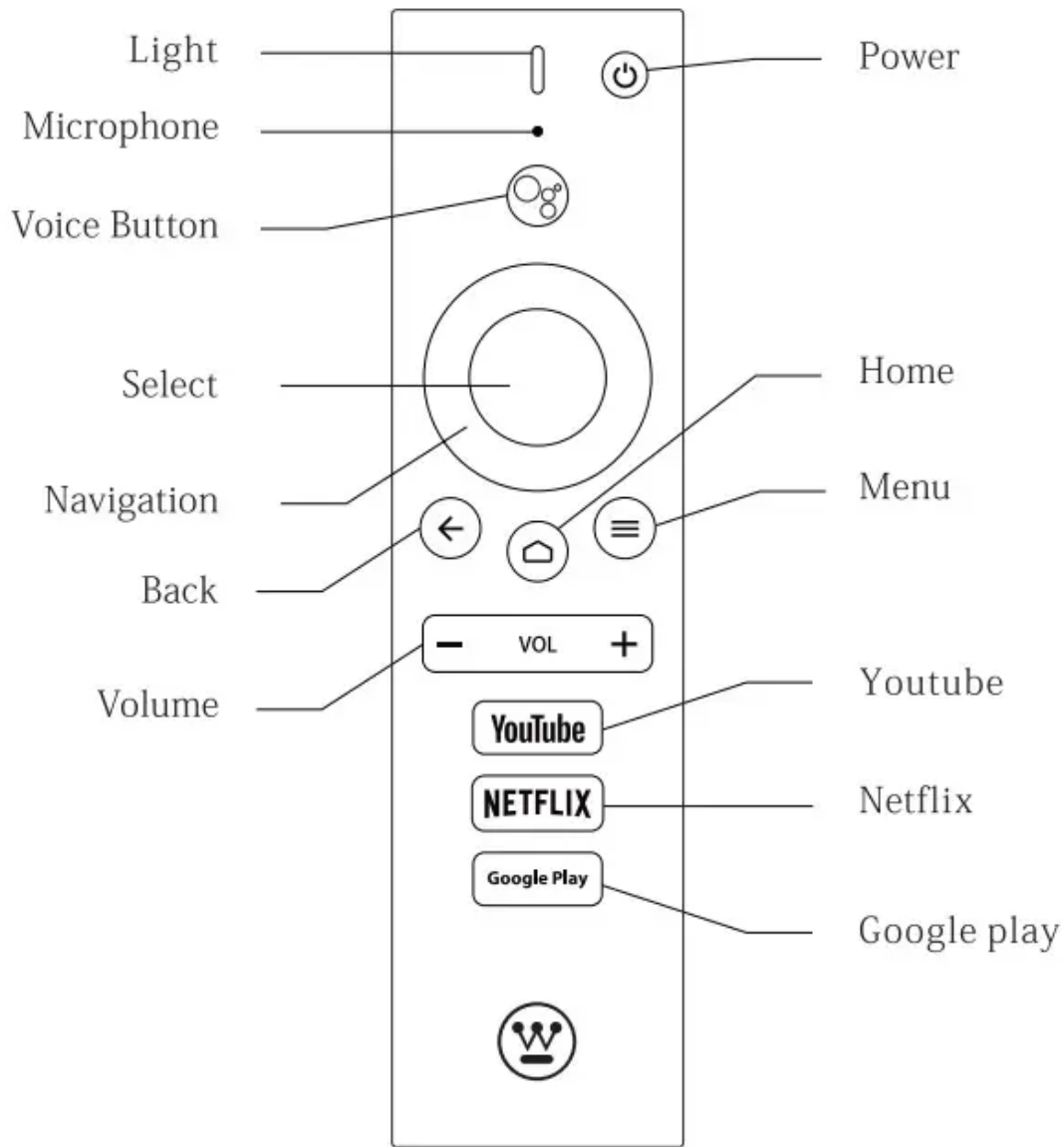

Voice Remote with Google Assistant



## CONNECTING EXTERNAL DEVICES

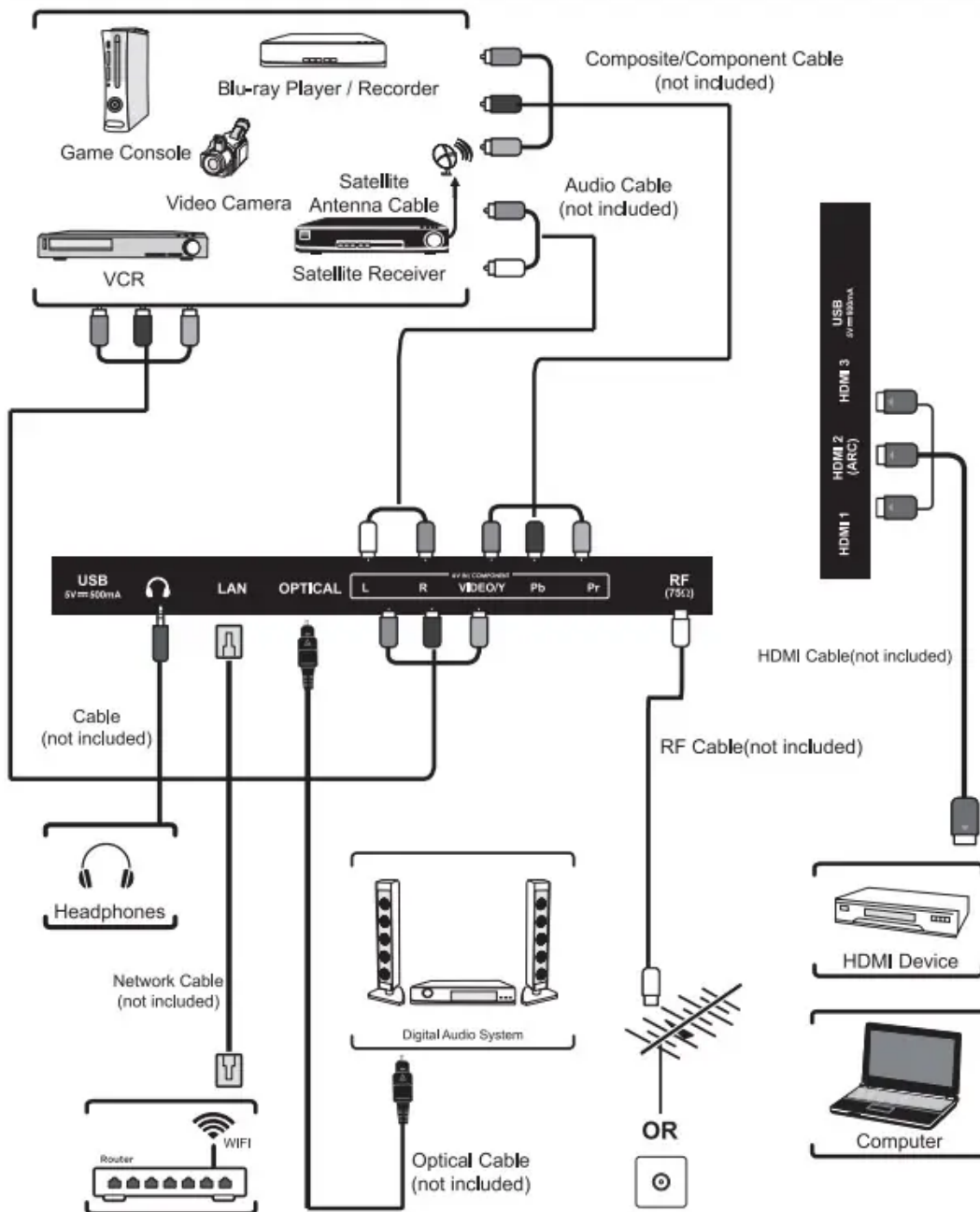







## CUSTOMIZING TV SETTINGS

### Turning On/Off Your TV

- Connect the power cord to the power socket after you have completed all the physical connections. At this stage, the TV will enter Standby Mode and the white LED indicator will illuminate.
- In Standby Mode, press the  button on the main unit or on the remote control to turn the TV on.

- You can control your Android TV using the the included remote, the Android TV Remote app, or the directional controller on the back of the TV. Download the Android TV Remote App to your iOS or Android device by visiting the appropriate app store for your device.

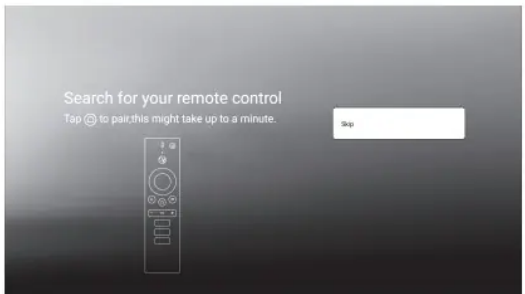
## Remote Pairing

 <p style="text-align: center;"><b>1</b></p>	<ul style="list-style-type: none"> <li>• Once you've connected your devices to your television and plugged it in, insert the included AAA batteries into the back of the remote and press the  "power" button on the remote. Your television will start and after press  and hold the  button on your remote for 10 seconds you will be prompted to pair your remote with your television. Pairing your remote to your television is necessary because the remote uses Bluetooth to send most button commands and voice commands to your television.</li> </ul>
 <p style="text-align: center;"><b>2</b></p>	<ul style="list-style-type: none"> <li>• If your television doesn't find your remote, remove and reinsert the batteries in your remote. If your remote doesn't pair with your TV  press and hold the  button on your remote for 10 seconds while your television is searching for your remote.</li> <li>• Once you've paired your remote, follow the on-screen instructions to set up your TV.</li> </ul>

## Setup Wizard

- The first time you turn the TV on, it will go into the Setup Wizard after remote pairing. Press the "Navigation" buttons to highlight and select your desired mode and press "Select" to confirm.

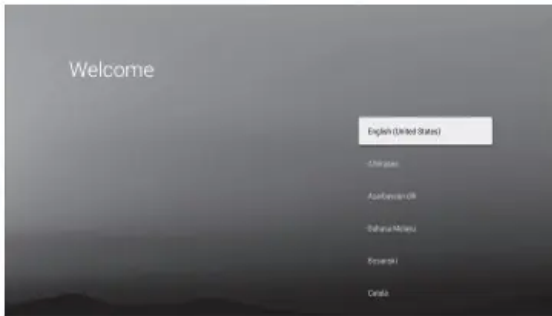

1

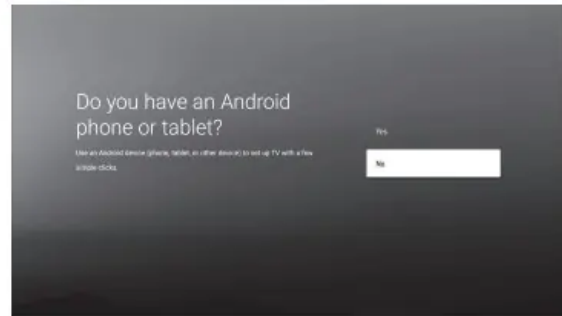

2

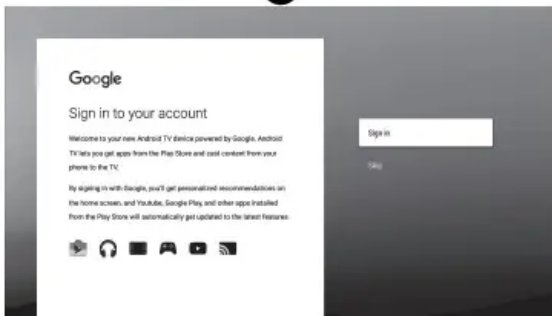

3

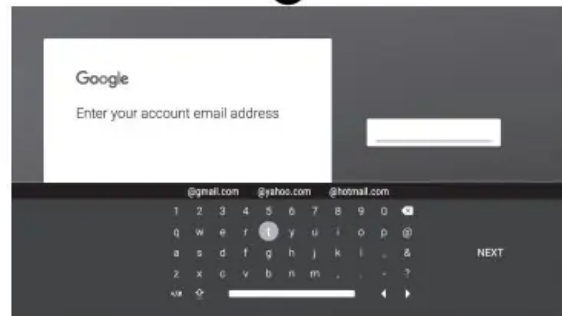

4

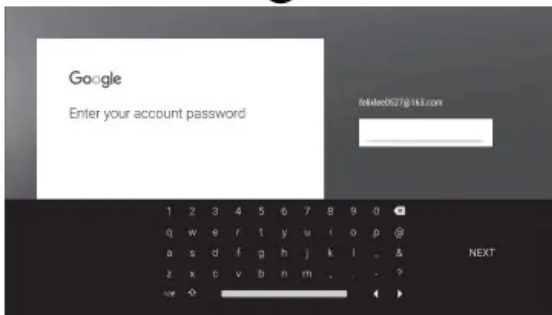

5

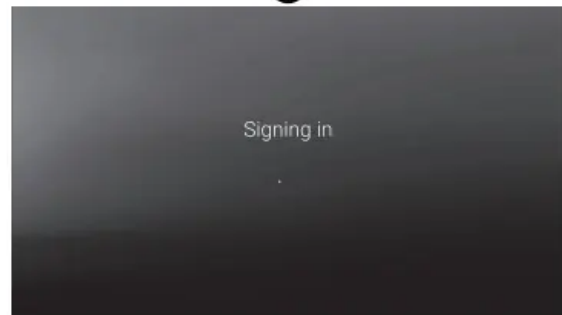

6

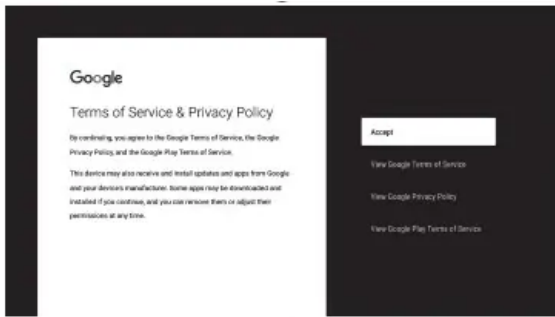

7

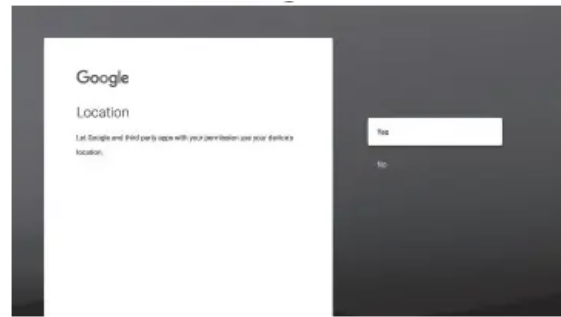

8

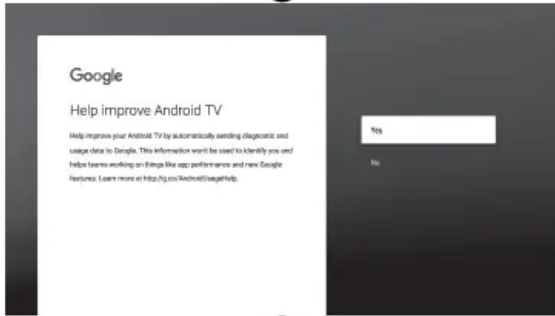

9

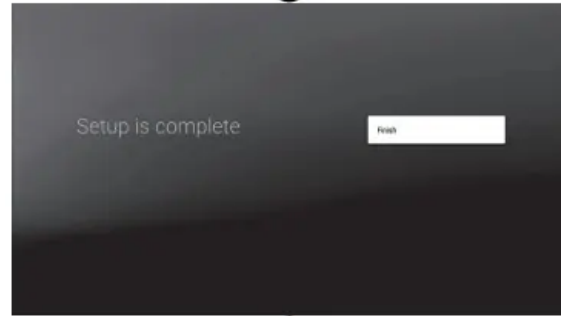

10

## Inputs

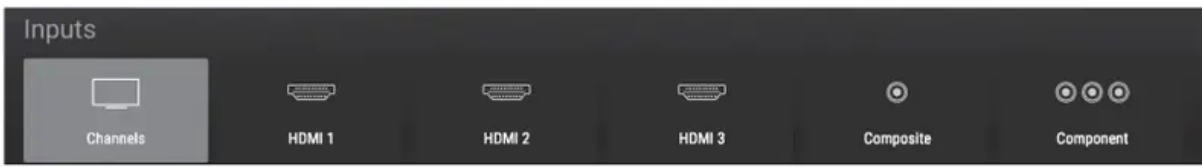

- Press Navigation buttons on the remote control to display the Inputs menu, then use the Navigation buttons to cycle among the different inputs: Antenna/HDMI1/HDMI2/HDMI3/ Composite/Component/Channels, then use the Navigation buttons to highlight the desired the Inputs menu and press Select to confirm.

## Volume Adjustment

- Press the VOL+/- buttons on the main unit or on the remote control to adjust the volume.
- If you wish to switch the sound off, press and hold the VOL- button on your remote to 0.

## Get The Most Out of Your Element Voice Remote With Google Assistant

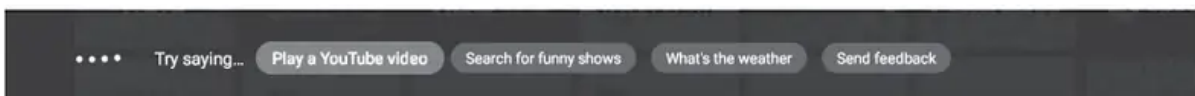

Connect to the Internet and sign in with your Google account

Connect your TV to the Internet and sign in with your Google account to use voice commands with your voice remote and to enjoy thousands of movies, shows, and games from Google Play, YouTube and your favorite apps. Voice search and personalized recommendations mean more time being entertained and less time hunting for something good.

#### About your Element Voice Remote with Google Assistant

Simply press and hold the Voice button  and speak. Release the button when you are done speaking.

You can use your voice to change channels or search for movies, TV shows, actors, directors, apps, games, and more. Simply say:

- Play Stranger Things
- Show me some popular action movies from 2016
- YouTube
- What is the weather like in New York?

#### ANDROID TV REMOTE CONTROL APP

Use your Android phone or tablet as a remote for your Android TV. Easily switch between d-pad and touchpad modes to navigate content and play games on your Android TV device. Tap the mic to start a voice search, or use the keyboard to input text on Android TV.

## TROUBLESHOOTING

If your TV does not operate normally or cannot be turned on, please check the following troubleshooting questions. Remember also to check any other connected electronic device, such as a DVD or Blu-ray player to pinpoint the problem. If the TV still fails to operate normally, please contact technical support.

<b>The TV does not operate properly</b>	
The TV does not respond when pressing any buttons	<ul style="list-style-type: none"> <li>• The TV may freeze up during use. Disconnect the power cord from the power socket for a few minutes. Reconnect the power cord and try to operate it again as usual.</li> </ul>
TV cannot be switched on	<ul style="list-style-type: none"> <li>• Check that the TV is connected to the power supply.</li> <li>• Make sure all connected AV devices are switched off before switching on your TV</li> </ul>
The remote control does not work	<ul style="list-style-type: none"> <li>• Check to see if there are any objects between the TV and the remote control causing an obstruction. Ensure that you are pointing the remote control directly at the TV.</li> <li>• Ensure that the batteries are installed with the correct polarity (+ to +, - to -).</li> <li>• Install new batteries.</li> </ul>
Power is suddenly turned off	<ul style="list-style-type: none"> <li>• Check the power of the TV. The power supply maybe interrupted.</li> <li>• Check if the sleep timer is set.</li> <li>• Check whether the Auto Standby is activated.</li> </ul>
<b>The video function does not work</b>	
No picture & no sound	<ul style="list-style-type: none"> <li>• Check whether the TV is switched on.</li> <li>• Try another channel. The problem may be caused by the broadcaster.</li> </ul>
Picture appears slowly after switching on	<ul style="list-style-type: none"> <li>• This is normal; the image is muted during the TV startup process. Please contact your service centre if the picture has not appeared after 5 minutes.</li> </ul>
No or poor color or poor picture	<ul style="list-style-type: none"> <li>• Adjust the settings in the Picture menu.</li> <li>• Try another channel. The problem may be caused by the broadcaster.</li> <li>• Check if video cables are connected properly.</li> </ul>

Horizontal/Vertical bar or picture shaking	<ul style="list-style-type: none"> <li>• Check for local interference such as an electrical appliance or power tool.</li> </ul>
Poor reception on some channels	<ul style="list-style-type: none"> <li>• The station or cable channel may be experiencing problems; tune to another station.</li> <li>• Station signal may be weak, reposition the antenna for better reception.</li> <li>• Check for sources of possible interference</li> </ul>
Lines or streaks in pictures	<ul style="list-style-type: none"> <li>• Check antenna (change the position of the antenna.)</li> </ul>
No pictures when connecting HDMI	<ul style="list-style-type: none"> <li>• Check if the input source is HDMI1/HDMI2/HDMI3.</li> </ul>
Pictures appear in wrong ratio	<ul style="list-style-type: none"> <li>• Adjust the Aspect Ratio settings in the SETUP menu or press the ASPECT button on the remote control.</li> </ul>
<b>The audio function does not work</b>	
Picture OK but no sound	<ul style="list-style-type: none"> <li>• Press the VOL +/- buttons.</li> <li>• Sound muted? Press the MUTE button.</li> <li>• Try another channel. The problem may be caused by the broadcaster.</li> </ul>
No output from one of the speakers	<ul style="list-style-type: none"> <li>• Adjust the Balance settings in the AUDIO menu.</li> </ul>
Unusual sound from inside the TV	<ul style="list-style-type: none"> <li>• A change in ambient humidity or temperature may result in an unusual noise when the TV is switched on or off and does not indicate a fault with the TV</li> </ul>
No sound when connecting HDMI	<ul style="list-style-type: none"> <li>• Check if the input source is HDMI1/HDMI2/HDMI3.</li> </ul>
Audio noise	<ul style="list-style-type: none"> <li>• Keep the RF coaxial cable away from the other connected cables.</li> </ul>
<b>Password</b>	

Lost password	<ul style="list-style-type: none"> <li>• Select the SET PASSWORD setting in the LOCK menu, then enter the following master password “8899”. The master password clears your previous password and allows you to enter a new password.</li> </ul>
<b>There is a problem in PC mode</b>	
The signal is out of range (invalid format)	<ul style="list-style-type: none"> <li>• Adjust the resolution, horizontal frequency, or vertical frequency</li> </ul>
Vertical bar or stripe on background & Horizontal Noise & Incorrect position	<ul style="list-style-type: none"> <li>• Use Auto configures or adjust clock, phase, or H/V position</li> </ul>
Screen color is unstable or show a single color	<ul style="list-style-type: none"> <li>• Check the signal cable.</li> <li>• Reinstall the PC video card</li> </ul>
<b>If the WIFI connection fails or APP has connection issue, please check the following troubleshooting questions</b>	
WIFI connection fails	<ul style="list-style-type: none"> <li>• Check signal strength for WIFI connection, the TV may be too far away from WIFI router.</li> <li>• Check "authentication" setting.</li> <li>• Make sure password is entered with correct upper or lower case letters.</li> <li>• Check if TV is connected correctly</li> <li>• Try powering off and unplugging TV to reset TV.</li> <li>• Try resetting the WIFI router, and also check for interference or WIFI channel problems.</li> </ul>
Problems with video streaming	<ul style="list-style-type: none"> <li>• Check if internet connection is fast enough for streaming HD or 4K videos.</li> </ul>
Netflix has connection issue	<ul style="list-style-type: none"> <li>• Try deactivating Netflix.</li> </ul>



## MAINTAINING

- Do not use your TV in areas that are too hot or too cold, because the cabinet may warp or the screen may malfunction. Your TV works best in temperatures that are comfortable to you.
- Storage temperatures are 32° to 122°F(0° to 50°C).
- Working temperatures are 32° to 95°F(0° to 35°C).
- Do not place your TV in direct sunlight or near a heat source.
- Always connect your television to a power outlet with protective ground connection.
- Minimum 5cm distances around the apparatus for sufficient ventilation
- The ventilation should not be impeded by covering the ventilation openings with items, such as newspapers, table-cloths, curtains, etc.
- No naked flame sources, such as lighted candles, should be placed on the apparatus.
- Attention should be drawn to the environmental aspects of battery disposal.

## SPECIFICATION

Panel Size	54.6 inch diagonally
Display Type	LED
Panel Technology	TFT
Panel 60 Hz Vs. 120 Hz	60 Hz
Display Resolution	2160P
HDMI Support	Up to 4K
Panel Resolution	3840 x 2160
Aspect Ratio	16:9
Channel Range	UHF: 14~69
Contrast Ratio-Panel	3200~4000:1
Brightness(Centre Typ.) Cd/M <sup>2</sup>	200~250
Response Time (G To G)	6.5 ms
Lamp Life (Typ. Hours)	>30,000 hours
Horizontal Viewing Angle (At CR≥10)	178
Vertical Viewing Angle (At CR≥10)	178
TV System	ATSC/NTSC
Channel Range	VHF: 2~13
Channel Range	CAVT: 1~135
Tuner Type	Frequency synthesized
Storage Space	16 GB 2 GB memory
Wall-mount(LxW-mm)	200*200 VESA(mm)

### Warning

This content is compiled from multiple sources and is provided for reference purposes only. It may not be complete or fully applicable to all situations. If you are unable to resolve your issue, please contact the product manufacturer or an authorized service provider for official support.

---

Document generated by [ManualsFile](#)

