

Operations

User interface

NOTE

- For detailed information about the refrigerator's functions, and apps, see the on-screen user manual available on the LCD display of your refrigerator.
- The content of apps and widgets and their design is subject to change. Support for apps and widgets may be discontinued without notice, depending on the content provider's policy.
- Children's use of the refrigerator's functions, apps, and services must be supervised by adults.
- The PANDORA apps are only available in the United States.

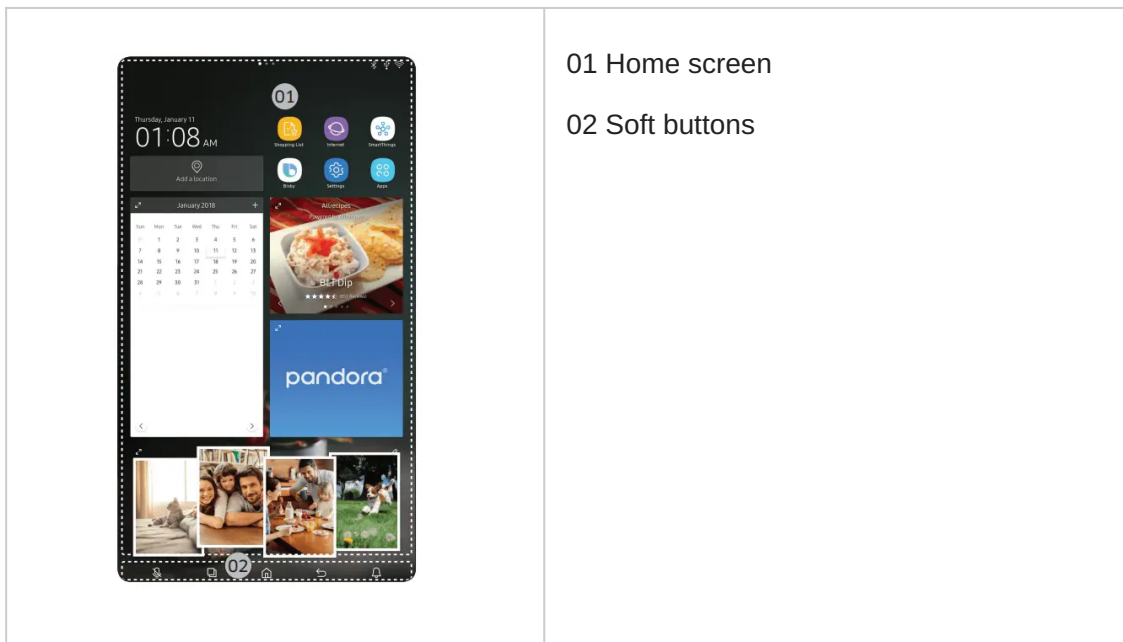

01 Home screen





01 Apps & Widgets

- Tap a desired app or widget to launch it.
- Tap and hold an app or widget to enter Edit mode. A grid appears. In Edit mode, you can drag and drop an app or widget to a new position on the grid. When you move the app or widget to a new grid location, the location turns blue if it is available. If it is not available, it turns red.
- You can add an app or widget that has been removed from the Apps list.

02 Status bar

- Displays the status of various functions. (Refer to the following Icon descriptions table.)

Icon descriptions

Bluetooth (⌘)	Indicates Bluetooth connection status.
USB (ψ)	Indicates USB connection status. NOTE The refrigerator supports USB memory that is formatted in the FAT32 or exFAT file systems. NTFS is not supported. Be sure to convert NTFS to FAT32 or exFAT before use.
Remote Management (Ⓜ)	Turns on when Remote Management is enabled and running.
Network (⊞)	Indicates network connection status in 5 levels (Off, 1-4).
Software Update (Ⓜ)	Indicates that the newest version of the refrigerator's software has been downloaded from the server and is ready to update.

Notification (L)	Indicates there is a notification message.
Cloud sync (↻)	Indicates Family Hub is receiving data from the cloud server.
Energy Saver (ψ)	Indicates Energy Saver is on.

02 Soft buttons

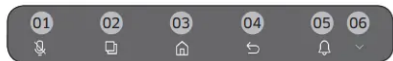

01 Microphone

- Tap to turn the microphone on or off.

02 Task Manager

- Tap to open the Task Manager.
- See the Task Manager section for details.

03 Home

- Tap to open the Home screen.

04 Return

- Tap to return to the previous screen.

05 Notification

- Tap to display the Quick Panel.

06 Hide/Show

- Tap to hide or show Soft buttons.
- The Hide/Show button only appears when an app is active.

Fridge Manager

To access Fridge Manager, swipe the Home screen to the left, and then tap the Fridge Manager widget.

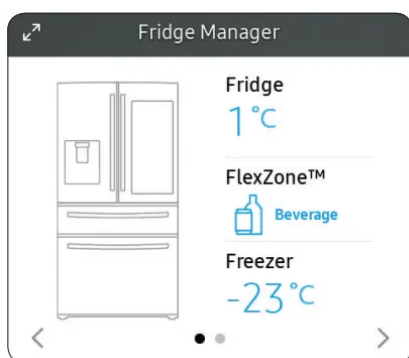

- The design of the Fridge Manager widget differs with the model.
- On the Fridge Manager widget, the current fridge and freezer temperatures are displayed.
- For detailed settings, tap the widget to open the Fridge Manager.

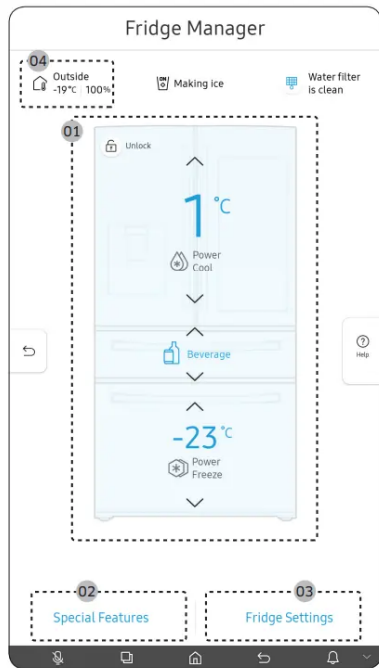

The Fridge Manager is a graphical representation of your refrigerator. The top half represents the refrigerator compartment, and the bottom half represents the freezer compartment. The temperature or mode settings for each are displayed over each section. Fridge Manager At a Glance

01 Temperature

Changes the set temperature in the fridge or freezer. You can also turn on and turn off the refrigerator's Power Cool function and the freezer's Power Freeze function.

- Power Freeze speeds up the freezing process at maximum fan speed. The freezer keeps running at full speed for several hours and then returns to the previous temperature.

- To freeze large amounts of food, activate Power Freeze at least 20 hours before putting the food in the freezer.

02 Special Features

View a short explanation of some of the refrigerator's special features.

03 Fridge Settings

Change many of the fridge's settings including settings for ice making, the door alarm, and the temperature units (°F or °C). See the next page for details.

04 External Conditions

Displays the external (ambient) temperature and humidity

NOTE :Also displayed is the Ice Off (ice making off) indicator at the top, center. When the indicator displays Ice Off, the refrigerator's ice maker is turned off.

Ice Maker (applicable models only)	Turns the icemaker on and off. Tap and drag the button to turn on or off. Note that if the ice bucket is full of ice, the refrigerator does not start making ice when you tap and drag this button (turning the Ice Maker on), but displays the Ice Full indicator on the main screen. If you hold down the dispenser lever for 5 seconds, the Ice Maker Off status changes to Ice Maker On.
Dispenser Lock (applicable models only)	Turns the ice and water dispensers on and off. Tap to set Dispenser Lock on or off.
Door Alarm	The door alarm sounds if you leave the door open. Tap and drag the button to turn on or off.
Temp. Unit	Switch the temperature scale between Celsius and Fahrenheit. Touch °F or °C to change the scale.
Water Filter (applicable models only)	Provides a water filter replacement tutorial and lets you reset the water filter replacement indicator. Tap to open. NOTE <ul style="list-style-type: none"> After installing the water filter, tap Water Filter, and then tap Reset. Tapping Reset re-initializes the function that measures the time remaining until the water filter needs to be replaced again. If you tap Buy Filter, you will be directed to the website where you can purchase a water filter.

Self Check	Self Check is a self diagnoses function. Tap to open. Tap Start to run.
Energy Saver	Tap and drag this button to turn Energy Saver mode on and off. The Energy Saver function automatically turns off when power is supplied to the refrigerator. The settings for Energy Saver may differ with the model. If condensation or water drops appear on the doors, turn the Energy Saver mode off.
Demand Response (applicable models only)	Works with the Smart Grid energy saving manager. Tap to open. Tap and drag the button to turn on or off. See the Smart Grid section in this manual for more information.

Cooling Off	Cooling Off mode (also called Shop mode), is designed for use by retailers when they are displaying refrigerators on the shop floor. In Cooling Off mode, the refrigerator's fan motor and lights work normally, but the compressors do not run, and the refrigerator and freezer do not get cold. If Cooling Off is turned on, all cooling controls will turn to OFF on the Fridge Manager. <ul style="list-style-type: none"> To activate Cooling Off, tap Activate > Proceed from Cancel/Proceed. To deactivate Cooling Off, tap Deactivate > Proceed from Cancel/Proceed.
-------------	--

Settings

Display	<ul style="list-style-type: none"> You can set the screen brightness, wallpapers, auto wake-up, motion detector, theme, screen timeout, and duration of the screen saver.
Sound	<ul style="list-style-type: none"> Set the volume and equalizer and turn on or turn off the touch sound.
Wi-Fi	<ul style="list-style-type: none"> Turn on or turn off a Wi-Fi connection. The current Wi-Fi network is listed first in the access point (AP) list.
Bluetooth	<ul style="list-style-type: none"> Up to 4 recently paired Bluetooth devices are listed. To add a new device when 4 paired devices are listed, first unpair a paired device from the device list. Available devices are Bluetooth-enabled headsets, headphones, and speakers.
Voice	<ul style="list-style-type: none"> You can check the Voice function language, turn on or turn off Voice wake-up, select Wake Word, register and manage Voice ID, and check information about Bixby.
Profile	<ul style="list-style-type: none"> You can add, edit, or delete a profile.
Security	<ul style="list-style-type: none"> Enable or disable restrictions on Family Hub features and apps.
Language	<ul style="list-style-type: none"> Select a preferred language. Available languages depend on the sales region.

Date and Time	<ul style="list-style-type: none"> Make sure the Auto update function is on with a proper Wi-Fi network connection. Open the fridge door and locate the display reset button on the inner side of the door. Press the button and press again to reset the display. Then, the date and time will be synced by the time server. You can change the time zone through the Time zone menu.
About Device	<ul style="list-style-type: none"> Make sure the Software Update function is on with a proper Wi-Fi network connection. When updates are available, the Update button becomes active. When updates are complete, the refrigerator restarts automatically. Legal information displays the Open Source License Agreement. Tap the list item to open the Open Source Announcement.
Easy Connection	<ul style="list-style-type: none"> Easy Connection can be used with Samsung Smartphone apps, and allows you to connect your device to the same home Wi-Fi network that your smartphone is connected to.
Clean screen mode	<ul style="list-style-type: none"> Turn on so you can clean the screen without activating any apps.

Accessibility	<ul style="list-style-type: none"> Set to turn on or off the screen reader function for blind and low-vision users.
Online Manual	<ul style="list-style-type: none"> The online manual will walk you through various menus and apps that the refrigerator provides directly on the display.
Factory Data Reset	<ul style="list-style-type: none"> Tap Reset to restart the refrigerator in Factory Data Reset mode. All user data will be removed permanently. Data that will be removed includes account information, memos, photos, and user settings. <p>⚠ CAUTION Once factory reset is complete, no user data can be recovered.</p>
Remote Management	<ul style="list-style-type: none"> Use Remote Management to allow a service representative to remotely diagnose problems and provide solutions. Remote Management requires a Wi-Fi connection. The Remote Management menu does not appear on models that do not support Remote Management.

Display reset (applicable models only)

If the display is not working correctly, try resetting the display. This may resolve the problem.

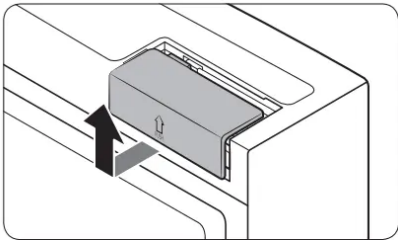
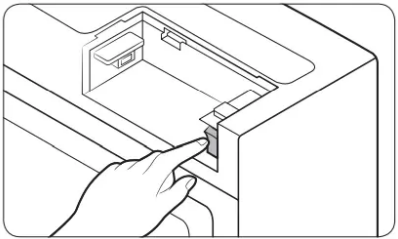
	<ol style="list-style-type: none"> 1. Open the right-side fridge door and locate the switch cover on the top right corner of the door. 2. Push up the cover to reveal the power switch.
	<ol style="list-style-type: none"> 3. Turn the switch off, and then turn it on again. 4. Reinsert the switch cover. You will hear a click when the cover is in place.

SMART GRID Function (Demand Response) (applicable models only)

When the refrigerator operates in SMART GRID (Demand Response) mode, the Energy Management Refrigerator function can control energy usage or delay the operation of some functions to save money when energy prices or demand are the highest.

Using the SMART GRID (Demand Response) Function

This feature monitors energy prices and demand information from your utility company and sends notifications to the refrigerator to run high energy consuming tasks during offpeak times when electricity costs and demand are lower.

If the refrigerator receives a control signal from the utility company, the refrigerator will display the DAL (L3) ~ TALR (L4) levels on the refrigerator display and control the power consumption according to the level.

Exception condition: The DAL and TALR control signals from a utility company work as long as product performance is maintained.

If the refrigerator receives the SMART GRID (Demand Response) signal (DAL or TALR), the refrigerator will operate in Delay Appliance Load or Temporary Appliance Load Reduction mode.

- Delay Appliance Load (L3): The refrigerator responds to a DAL signal by providing a moderate load reduction for the duration of the delay period. This function controls functions that consume a lot of energy such as adjusting the Cooling system, running the defrost cycle, and making ice.
 - DAL mode is automatically deactivated after it lasts for the amount of time stipulated by the DAL signal (max. 4.5 hours) or when the Override function is turned on.
- Temporary Appliance Load Reduction (L4): The refrigerator responds to a TALR signal by aggressively reducing the load for a short time period. This function reduces energy consumption by stopping the compressor and controlling the functions that consume a lot of energy such as the defrost cycle and making ice.
 - TALR (L4) mode is automatically deactivated after it lasts for the received duration (max. 15 minutes), or when the Override function is turned on. The mode is immediately deactivated and the refrigerator returns to the normal state when the door is opened or closed, or the dispenser is used.

To check the MAC address

1. Tap the Settings icon on the Home screen.
2. Scroll down to and open About Device.
3. The screen displays (among others) the Wi-Fi MAC address.

Override Mode

When you want the refrigerator to ignore the SMART GRID (Demand Response) signal from the utility company, you can activate OVERRIDE mode.

When you activate OVERRIDE mode, the refrigerator ignores the SMART GRID (Demand Response) signal and is not controlled by the utility company.

Activating and deactivating Override mode

1. Tap the Fridge Manager icon.
2. On the bottom of the Fridge Manager screen, tap the Fridge Settings icon.
3. Tap Demand Response.

4. Slide the DAL/TALR override button to the ON or OFF position.

Using the Energy Management Function

The Energy Management function enables you to control and monitor your Energy Management refrigerator using the SmartThings app for your convenience.

1. Operational Status

- You can check the DR and Override status.

2. Energy Consumption Reporting

- Shows the accumulated power consumption. Power consumption data is updated every 5 minutes.

3. Delay Defrost Capability

- The Delay Defrost Capability function saves energy by delaying the defrost operation to a time specified by the user. You can configure the time, and this function will save energy during the specified period in a 24 hour cycle. If the time is not set, the function works with the default time settings. The default time settings are below:
- 6 am to 10 am: November 1st to April 30th.
- 3 pm to 7 pm: May 1st to October 31st.

Recommendations for voice recognition

For the voice recognition function, there is a built-in microphone on top of the refrigerator's display. To use the voice recognition function:

- Stand no more than 3 feet (1 meter) from the refrigerator and speak loudly and clearly towards the built-in microphone.
- Speak at a regular pace. Reduce ambient noises, such as noises from a living-room TV.

Special features

Water/Ice dispenser (applicable models only)

With the dispenser, you can dispense water with or without ice.

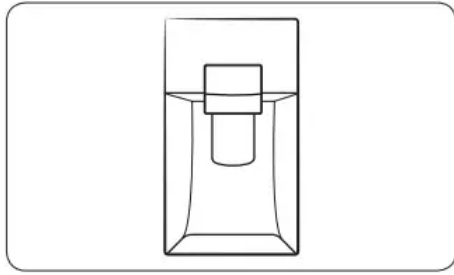

The water dispenser offers 3 options: chilled water, cubed ice, and crushed ice. To dispense chilled water, press Water on the dispenser panel. Put a water glass against dispenser lever, and then push the dispenser lever.

To dispense water with ice

1. With the Ice Maker enabled, press Cubed Ice or Crushed Ice to select the ice type.
2. Place a water glass against the dispenser lever and push it. Ice will be dispensed from the dispenser.
3. Press Water to select water.
4. Place the glass against the dispenser lever, and then push it. Water will be dispensed from the dispenser.

Ice maker (applicable models only)

The refrigerator has a built-in ice maker that automatically dispenses ice so that you can enjoy filtered water with cubed or crushed ice.

Ice making

After you have installed your refrigerator and plugged it in, follow these instructions to ensure proper ice making and to keep the ice bucket full of ice:

1. Let the refrigerator run at least 24 hours without dispensing ice for optimal performance.
2. Dispense the first 4 to 6 ice cubes into a glass.
3. Wait another 8 hours and dispense another 4 to 6 ice cubes.
4. Then, wait another 16 hours and dispense the first glass-full of ice.

Diagnosis

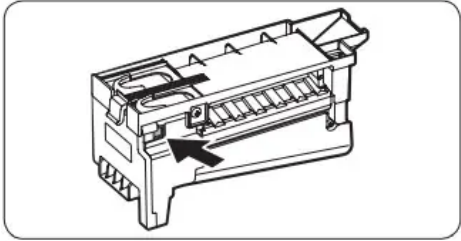
	<p>If ice does not dispense, first check the ice maker.</p> <p>To check the ice maker</p> <ol style="list-style-type: none">1. Press Test on the side of the ice maker. You will hear a chime (ding-dong) when you press the button.2. You will hear another chime if the ice maker is operating properly.
---	---

Ice Maker Off

To disable the icemaker, tap Fridge Manager > Fridge Settings > Ice Maker on the Home screen, and then select Off. Make sure to empty the ice bucket.

Remaining ice cubes may clump together, making it difficult to remove them.

To remove the ice bucket, see the ice bucket section

Water clouding



Water supplied to the refrigerator flows through a core alkaline filter. During this filtering process, the water pressure of the water increases and the water becomes saturated with oxygen and nitrogen. This causes the water to look misty or cloudy temporarily when dispensed. This is normal and the water will look clear after a few seconds.

Maintenance

Handling and care

Ice bucket (applicable models only)

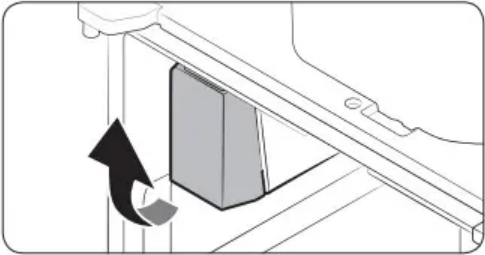
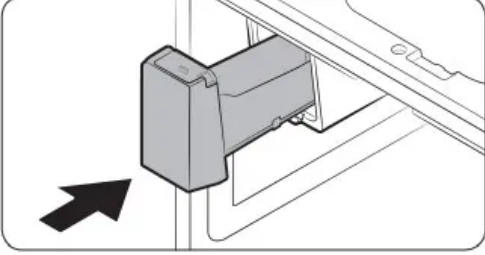
If you do not dispense ice for an extended period, ice may form clumps inside the bucket. If this happens, remove and empty the ice bucket.

	<ol style="list-style-type: none"> 1. To remove the ice bucket, gently lift it up, and then pull it out slowly while holding the bottom of the bucket with one hand and the side with the other hand. 2. Empty the bucket.
	<ol style="list-style-type: none"> 3. When done, put the bucket back into position. If the bucket does not fit in, turn the helix screw 90 degrees, and then try again.
	<p>If the ice bucket is not firmly inserted, turn the ice screw 90 degrees, and then try again.</p>

Tempered glass shelves (fridge)

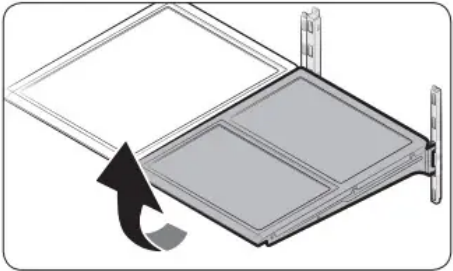
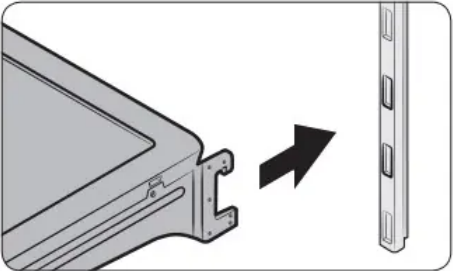
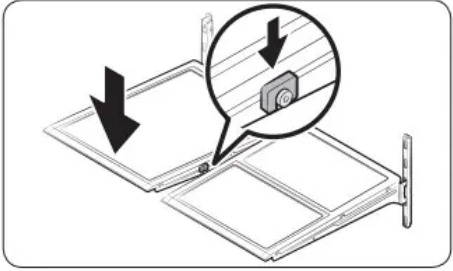

	<ul style="list-style-type: none"> • To remove a shelf, fully open the corresponding door. Hold the front of the shelf, and then gently lift up and slide out.
	<ul style="list-style-type: none"> • To reinsert, hold the shelf at an angle so the front is higher than the back, and then insert the top hook into the top shelf notch. Then, lower the shelf and insert the bottom shelf hook into the bottom shelf notch.
	<p>CAUTION</p> <ul style="list-style-type: none"> • The tempered glass shelves are heavy. Use caution when removing them • The shelf must be inserted correctly. Do not insert upside down. • Glass containers may scratch the surface of glass shelves.

Door bins

The top door bin section has a marked line to ensure easy removal and proper reinsertion.

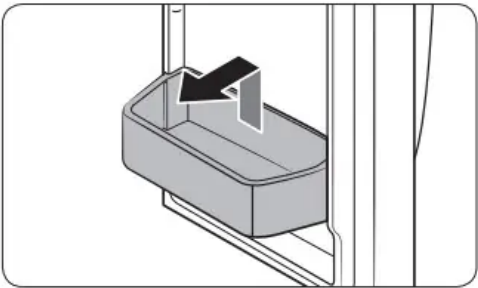
	<p>Lift up the door bin, and then pull out straight.</p>
---	--

Vegetable & fruit drawers

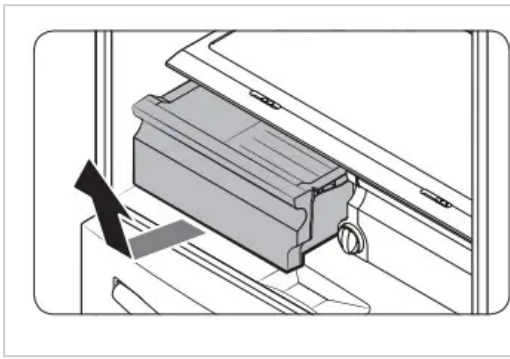

Gently lift up the front of the drawer and slide out.

We recommend that you remove the door bins before removing the drawer. This is to prevent damage to the door bins.

Vegetable shelf

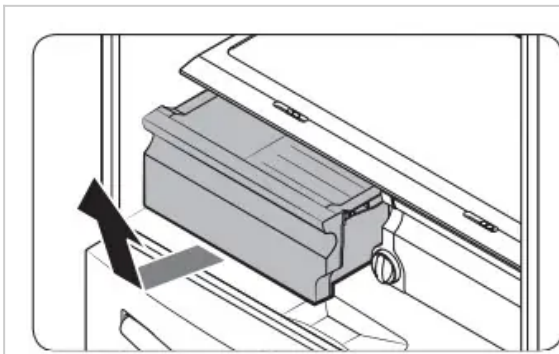

1. Slide out the left-side vegetable drawer.

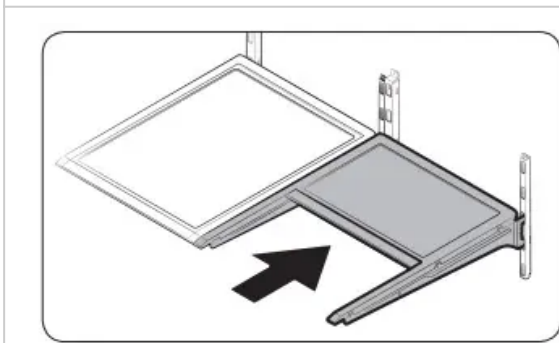

2. Slide in the right-side foldable shelf.

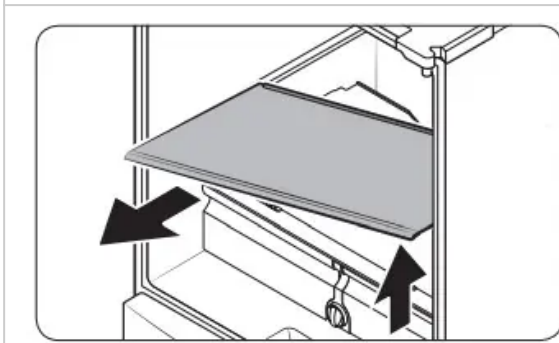

3. While supporting the vegetable shelf with one hand, slide it out with the other hand.

Ice bucket (applicable models only)

To remove the ice bucket, see the Maintenance section

FlexZone™ basket

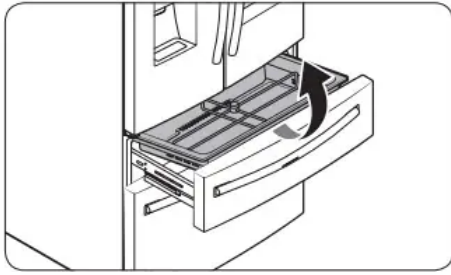

- To remove, fully open the FlexZone™ drawer. Lift up the FlexZone™ basket, and then pull out with both hands.
- To reinsert, fully open the FlexZone™ drawer. While tilting up the front of the basket, insert the rear of the basket into the rail assembly. Lower the front until the basket settles down.
- If the divider lock does not function, wipe the bars to remove moisture on them.

To remove the divider and the metal cooling plate (applicable models only) from the FlexZone™ basket

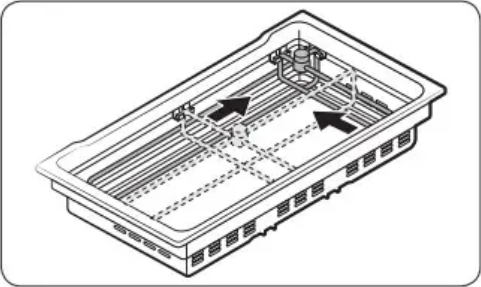
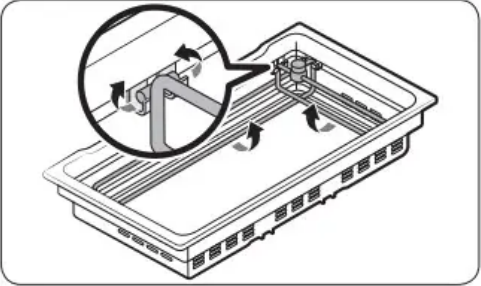
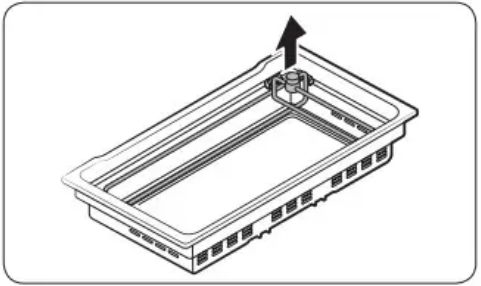
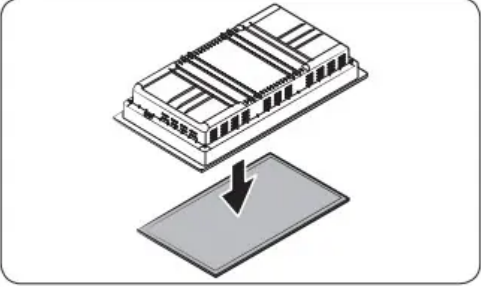
	<ol style="list-style-type: none"> 1. Unlock the divider by turning the divider dial counter clockwise. 2. Slide the divider to the end as shown.
	<ol style="list-style-type: none"> 3. The divider has width and length bars. Push the lower part of each bar inward to unlock. See the figures for details.
	<ol style="list-style-type: none"> 4. Hold the divider and pull up to remove.
	<ol style="list-style-type: none"> 5. Turn over the basket to remove the metal cooling plate.

To reinsert the metal cooling plate

Reinsertion in the reverse order of removal.

Reinsert the divider into the FlexZone™ basket firmly until you hear a click.

Freezer basket divider

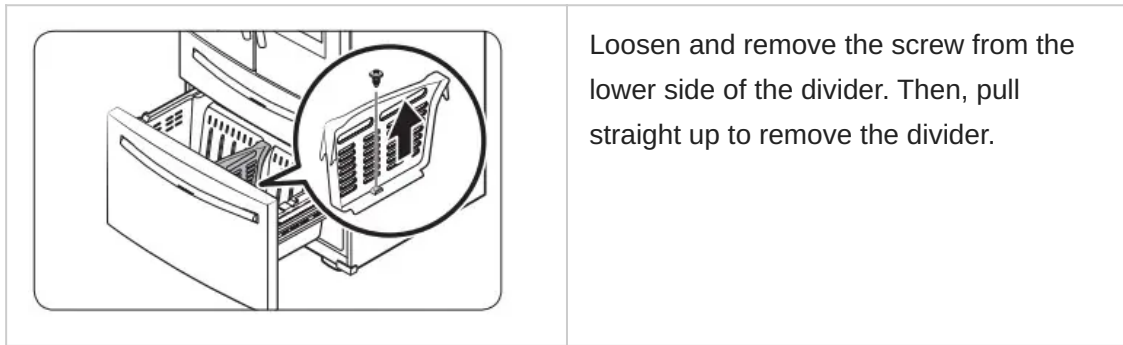

Cleaning

Interior and exterior

WARNING

- Do not use benzene, thinner, home/car detergent, or Clorox™ for cleaning. They may damage the surface of the refrigerator or cause a fire.
- Do not spray water onto the refrigerator. This may cause electric shock.
- Do not put fingers or any objects into the dispenser outlet.

Regularly use a dry cloth to remove all foreign substances such as dust or water from the power plug terminals and contact points.

To clean the refrigerator

1. Unplug the power cord.
2. Use a moistened, soft, lint-free cloth or paper towel to clean the refrigerator's interior and exterior.
3. When done, use a dry cloth or paper towel to dry well.
4. Plug in the power cord.

Inner-view camera

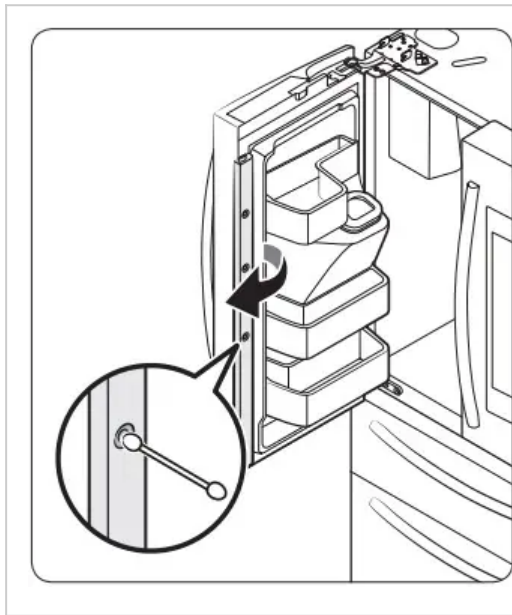

NOTE

Use a cotton swab or microfiber cloth to clean the camera on the left-side door of the fridge.

Replacement

Water filter (applicable models only)

WARNING

- Do not use third-party water filters. Use only Samsung-provided or -approved filters.
- Unapproved filters may leak and damage the refrigerator, causing electric shock. Samsung is not responsible for any damage that may occur from use of third-party water filters.

The filter indicator () turns red to let you know it is time to replace the water filter. Before replacing the filter, shut off the water supply line.

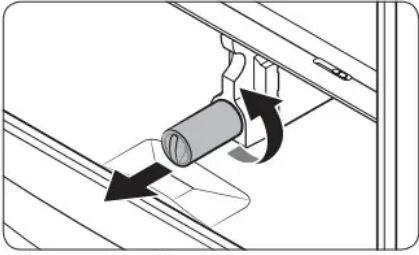
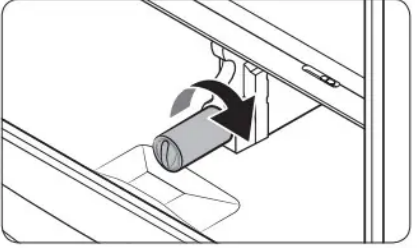
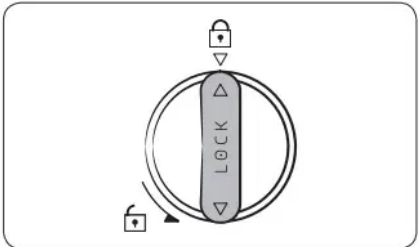
	<ol style="list-style-type: none"> 1. Turn the knob of the filter cartridge counter clockwise 90 degrees (1/4 turn). The filter cartridge unlocks. 2. Pull out to remove the cartridge. <ul style="list-style-type: none"> - If the water filter is severely contaminated, the cartridge may not be easy to remove. If that is the case, use force to remove the cartridge. - To prevent water leaks from the filter opening, pull the cartridge straight out while removing it.
	<ol style="list-style-type: none"> 3. Insert a new filter cartridge. Use only Samsung-provided or approved filters.
	<ol style="list-style-type: none"> 4. Turn the cartridge knob clockwise to lock into place. 5. On the Home screen, tap Fridge Manager > Fridge Settings > Water Filter, and then select Reset. The filter indicator turns off. 6. When you are done replacing the filter, open the water valve and run water through the dispenser for about 7 minutes. This is to remove impurities and air from the water line.

Reverse osmosis water filtration system

The water pressure of the water supply system to a reverse osmosis water filtration system must be between 35 psi and 120 psi (241 kPa and 827 kPa). The water pressure of the reverse osmosis water filtration system to the refrigerator's cold water line must be at least 40 psi (276 kPa). If the water pressure is below these specifications:

- Check if the sediment filter in the reverse osmosis system is blocked. Replace the filter if necessary.
- Refill the water tank in the reverse osmosis system with water.
- If your refrigerator has a water filter, it may further reduce the water pressure when used in conjunction with a reverse osmosis system. Remove the water filter.

For more information or servicing, contact a licensed plumbing professional.

LED Lights

To replace the LED lights on the refrigerator, contact a local Samsung service center.

Troubleshooting

General

Temperature

Symptom	Possible causes	Solution
Fridge/freezer does not operate. Fridge/freezer temperature is warm.	<ul style="list-style-type: none"> • Power cord is not plugged in properly. 	<ul style="list-style-type: none"> • Properly plug in the power cord.
	<ul style="list-style-type: none"> • Temperature control is not set correctly 	<ul style="list-style-type: none"> • Set the temperature lower.
	<ul style="list-style-type: none"> • Refrigerator is located near a heat source or direct sunlight. 	<ul style="list-style-type: none"> • Keep the refrigerator away from direct sunlight or a heat source
	<ul style="list-style-type: none"> • Not enough clearance between refrigerator and nearby walls or cabinets. 	<ul style="list-style-type: none"> • Make sure there is a gap of at least 2.5 inches (5 cm) between the refrigerator back and sides and any nearby walls or cabinets.
	<ul style="list-style-type: none"> • The refrigerator is overloaded. Food is blocking the refrigerator vents. 	<ul style="list-style-type: none"> • Do not overload the refrigerator. Do not allow food to block ventilation.
Fridge/freezer is over-cooling.	<ul style="list-style-type: none"> • Temperature control is not set correctly. 	<ul style="list-style-type: none"> • Set the temperature higher.
Interior wall is hot.	<ul style="list-style-type: none"> • Refrigerator has heat-proof piping in the interior wall. 	<ul style="list-style-type: none"> • To prevent condensation from forming, the refrigerator has heat-proof piping in the front corners. If the ambient temperature rises, this equipment may not work

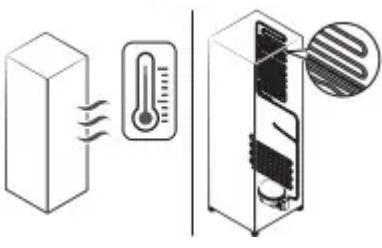
Symptom	Possible causes	Solution
		<p>effectively. This is not a system failure.</p> 

Odors

Symptom	Possible causes	Solution
Refrigerator has odors.	<ul style="list-style-type: none"> • Spoiled food. 	<ul style="list-style-type: none"> • Clean the refrigerator and remove any spoiled food.
	<ul style="list-style-type: none"> • Food with strong odors. 	<ul style="list-style-type: none"> • Make sure strong smelling food is wrapped airtight.

Frost

Symptom	Possible causes	Solution
Frost around the vents.	<ul style="list-style-type: none"> • Food is blocking the vents. 	<ul style="list-style-type: none"> • Make sure no food blocks the refrigerator vents.
Frost on interior walls.	<ul style="list-style-type: none"> • Door is not closed properly. 	<ul style="list-style-type: none"> • Make sure food does not block the door. Clean the door gasket.
Fruits or vegetables are frozen.	<ul style="list-style-type: none"> • Fruits or vegetables are stored in the FlexZone and the temperature was set too low. 	<ul style="list-style-type: none"> • Set the temperature of the FlexZone to a temperature appropriate for fruits or vegetables.

Condensation

Symptom	Possible causes	Solution
Condensation forms on the interior walls.	<ul style="list-style-type: none">• If door is left open, moisture enters the refrigerator.	<ul style="list-style-type: none">• Remove the moisture and do not leave a door open for extended periods of time.
	<ul style="list-style-type: none">• Food with high moisture content.	<ul style="list-style-type: none">• Make sure food is wrapped airtight.

Water/ice (dispenser models only)

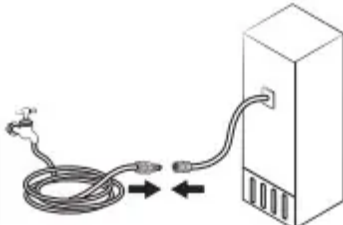
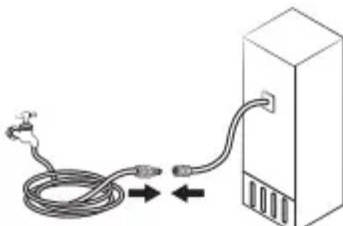

Symptom	Possible causes	Solution
Water flow is weaker than normal.	<ul style="list-style-type: none"> • Water pressure is too low. 	<ul style="list-style-type: none"> • Make sure the water pressure is between 20 to 120 psi (138 to 827 kPa).
Ice maker makes a buzzing sound.	<ul style="list-style-type: none"> • The ice maker function is activated, but the water supply to the refrigerator has not been connected 	<ul style="list-style-type: none"> • Press Ice Maker off .
Ice maker does not make ice.	<ul style="list-style-type: none"> • Ice maker has just been installed. 	<ul style="list-style-type: none"> • You must wait 12 hours for the refrigerator to make ice.
	<ul style="list-style-type: none"> • Freezer temperature is too low. 	<ul style="list-style-type: none"> • Set the freezer temperature below 0 °F (-18 °C) or -4 °F (-20 °C) in warm, ambient air.
	<ul style="list-style-type: none"> • Dispenser Lock is activated. 	<ul style="list-style-type: none"> • Deactivate Dispenser Lock.
	<ul style="list-style-type: none"> • Ice maker is off. 	<ul style="list-style-type: none"> • Turn on the ice maker.
Ice does not dispense.	<ul style="list-style-type: none"> • Ice may jam if the ice dispenser is not used for a long time (approx. 3 weeks). 	<ul style="list-style-type: none"> • If you won't be using the refrigerator for a long time, empty the ice bucket and turn off the ice maker.
	<ul style="list-style-type: none"> • Ice bucket is not properly inserted 	<ul style="list-style-type: none"> • Make sure the ice bucket is properly inserted.

Symptom	Possible causes	Solution
	<ul style="list-style-type: none"> Water line is not connected properly or water supply is not on. 	<ul style="list-style-type: none"> Check if the water line is installed correctly. Check if the water line stop cock is closed. 
Water does not dispense.	<ul style="list-style-type: none"> Water line is not connected properly or water supply is not on. 	<ul style="list-style-type: none"> Check the water installation conditions. 
	<ul style="list-style-type: none"> Dispenser Lock is activated. 	<ul style="list-style-type: none"> Deactivate Dispenser Lock
	<ul style="list-style-type: none"> A third-party water filter was installed. 	<ul style="list-style-type: none"> Use only Samsung-provided or approved filters. Unapproved filters may leak and damage the refrigerator.
	<ul style="list-style-type: none"> Water filter indicator turns on or blinks. 	<ul style="list-style-type: none"> Replace the water filter. After replacing, reset the filter indicator sensor.

Do you hear abnormal sounds from the refrigerator?

Before calling for service, review the checkpoints below. Any service calls related to normal sounds will be charged to the user.

These sounds are normal.

- When starting or ending an operation, the refrigerator may make sounds similar to a car engine ignition. As the operation stabilizes, the sounds will decrease.

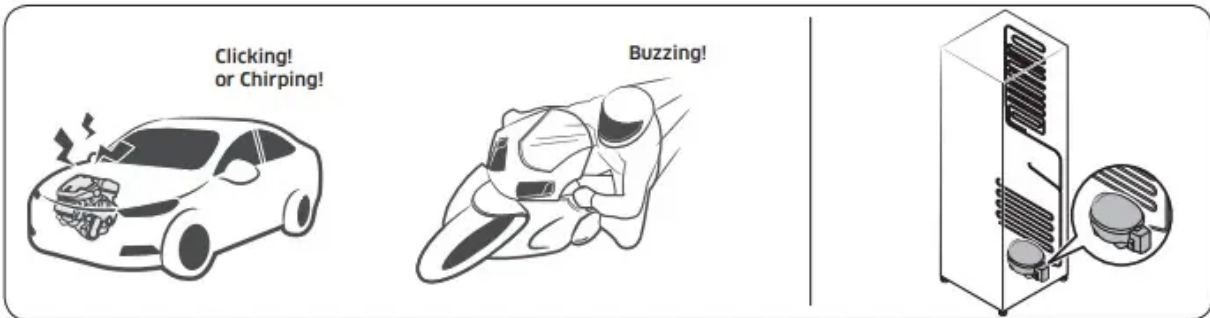

- While the fan is operating, these sounds may occur. When the refrigerator reaches the set temperature, the fan sound will stop.

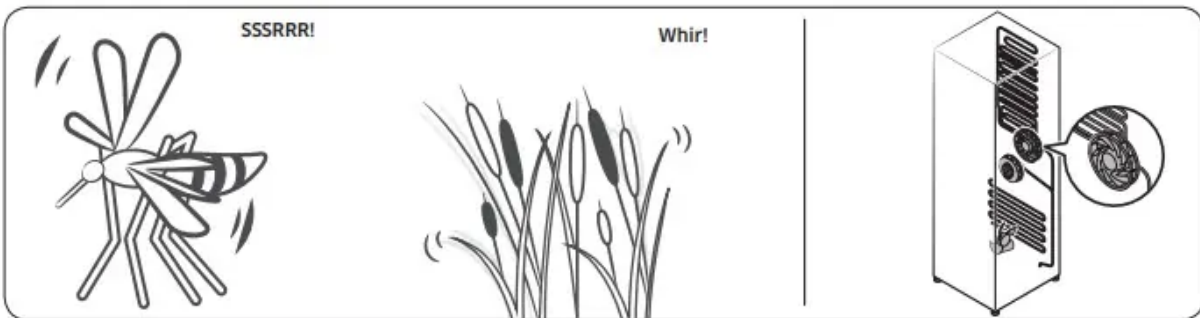

- During a defrost cycle, water may drip on the defrost heater, causing sizzling sounds.

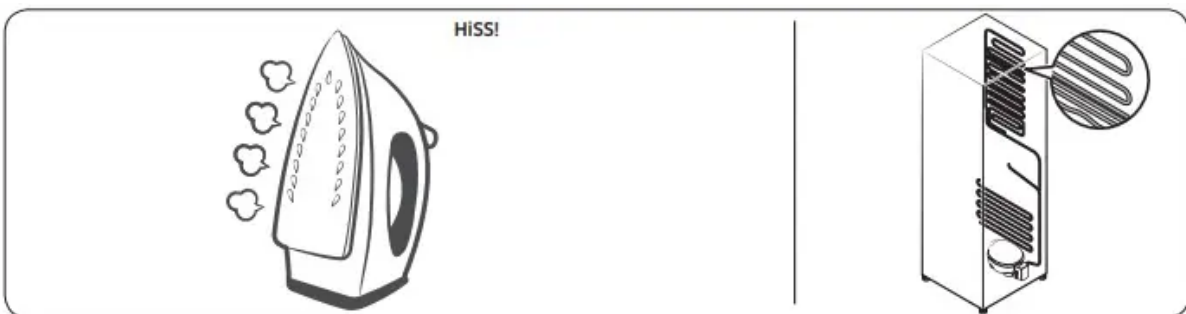

- As the refrigerator cools or freezes, refrigerant gas moves through sealed pipes, causing bubbling sounds.

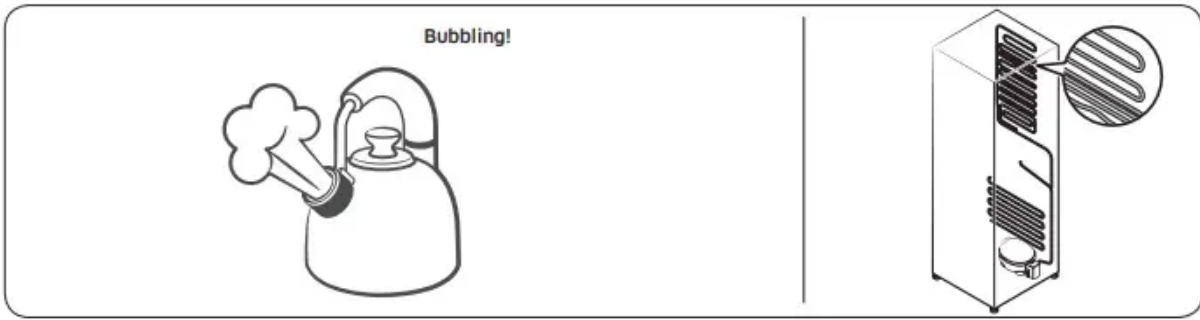

- As the refrigerator temperature increases or decreases, plastic parts contract and expand, creating knocking noises. These noises occur during the defrosting cycle or when electronic parts are working.

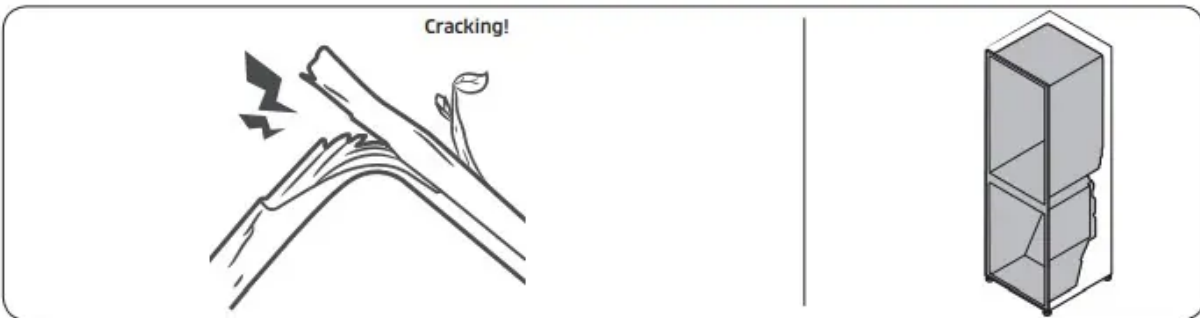

- For ice maker models: When the water valve opens to fill the ice maker, buzzing sounds may occur.
- Due to pressure equalizing when you open and close the refrigerator door, whooshing sounds may occur.

SmartThings

Symptom	Action
Could not find “SmartThings” in the app market.	<ul style="list-style-type: none"> • The SmartThings app is designed for Android 6.0 (Marshmallow) or later, iOS 10.0 or later, iPhone 6 or later, and is optimized for Samsung smartphones (Galaxy S and Galaxy Note series).
The SmartThings app fails to operate.	<ul style="list-style-type: none"> • The SmartThings app is available for applicable models only. • The old Samsung Smart Refrigerator app cannot connect with Samsung Smart Home models.
The SmartThings app is installed but is not connected to my refrigerator.	<ul style="list-style-type: none"> • You must log into your Samsung account to use the app. • Make sure that your router is operating normally. • If you have not connected your refrigerator to the SmartThings App after the app was installed, you must make the connection using the device registration function of the app.
Could not log into the app.	<ul style="list-style-type: none"> • You must log into your Samsung account to use the app. • If you don't have a Samsung account, follow the app's onscreen instructions to create one.
An error message appears when I try to register my refrigerator.	<ul style="list-style-type: none"> • Easy Connection may fail due to the distance from your access point (AP) or electrical interference from the surrounding environment. Wait a moment and try again.
The SmartThings app is successfully connected to my refrigerator but does not run.	<ul style="list-style-type: none"> • Exit and restart the SmartThings app or disconnect and reconnect the router. • Unplug the power cord of the refrigerator, and then plug it in again after 1 minute.

Samsung Family Hub

Symptom	Action
Could not find “Samsung Family Hub” in the app market.	<ul style="list-style-type: none">• The Samsung Family Hub app is available for smartphones that run Android 4.4 (KitKat) or higher, or iOS 8.0 or higher.
Could not log into the app.	<ul style="list-style-type: none">• You must log into your Samsung account to use the app.• If you don't have a Samsung account, follow the app's onscreen instructions to create one.

Smart Grid (applicable models only)



Symptom	Action
<p>What Do I Need to use the Energy Management and Smart Grid functions?</p>	<p>To use the Smart Grid (Demand Response) and Energy Management functions on your refrigerator, you need the following:</p> <p>Devices</p> <ul style="list-style-type: none"> • A wireless access point (router) • A Samsung Energy Management-supported refrigerator • A smartphone <p>Registration</p> <ul style="list-style-type: none"> • Connect your refrigerator to your home Wi-Fi network. • Register for the EMS service with your electric company. Your electric company must have an EMS (Energy Management System) supporting SEP (Smart Energy profile). <p>App</p> <ul style="list-style-type: none"> • Download the SmartThings app from the Google Play Store, Apple App Store, or Samsung Galaxy Apps. • Install and run the SmartThings app on your smartphone.
<p>Why isn't the Energy Management function working normally?</p>	<ul style="list-style-type: none"> • Make sure that your home router is operating normally with proper Internet service and connection. • Make sure that the refrigerator is connected to the AP (router). <p>Checkpoints</p> <ul style="list-style-type: none"> • Connect your smartphone to the router (AP, Access Point), and then check if you can browse the Internet on the smartphone.



Symptom	Action
Why isn't the Delay Defrost Capability working normally?	<ul style="list-style-type: none"> • Make sure that your home router is operating normally with proper Internet service and connection.

LCD

Symptom	Action
Cannot connect to my TV.	<ul style="list-style-type: none"> • This refrigerator can connect only with Samsung Smart TV 6400 series or higher models released since 2015. Please check the model name of your TV first. • Network connections may suffer temporary interruptions. Turn your TV off, and then try again.
The inner view picture looks bulged out or incomplete.	<ul style="list-style-type: none"> • The edges of the inner view may look bulged out. The bulging is caused by the convex lens of the camera. • The inner view may be incomplete due to the blind spots on the left and right corners or be screened depending on the layout of food items. Make sure to place food items in the front center.
The displayed measurement on the Fridge Manager is not correct.	<ul style="list-style-type: none"> • The displayed conditions may differ from the actual temperature and humidity.

Warning

This content is compiled from multiple sources and is provided for reference purposes only. It may not be complete or fully applicable to all situations. If you are unable to resolve your issue, please contact the product manufacturer or an authorized service provider for official support.

