

## Parts and Accessories

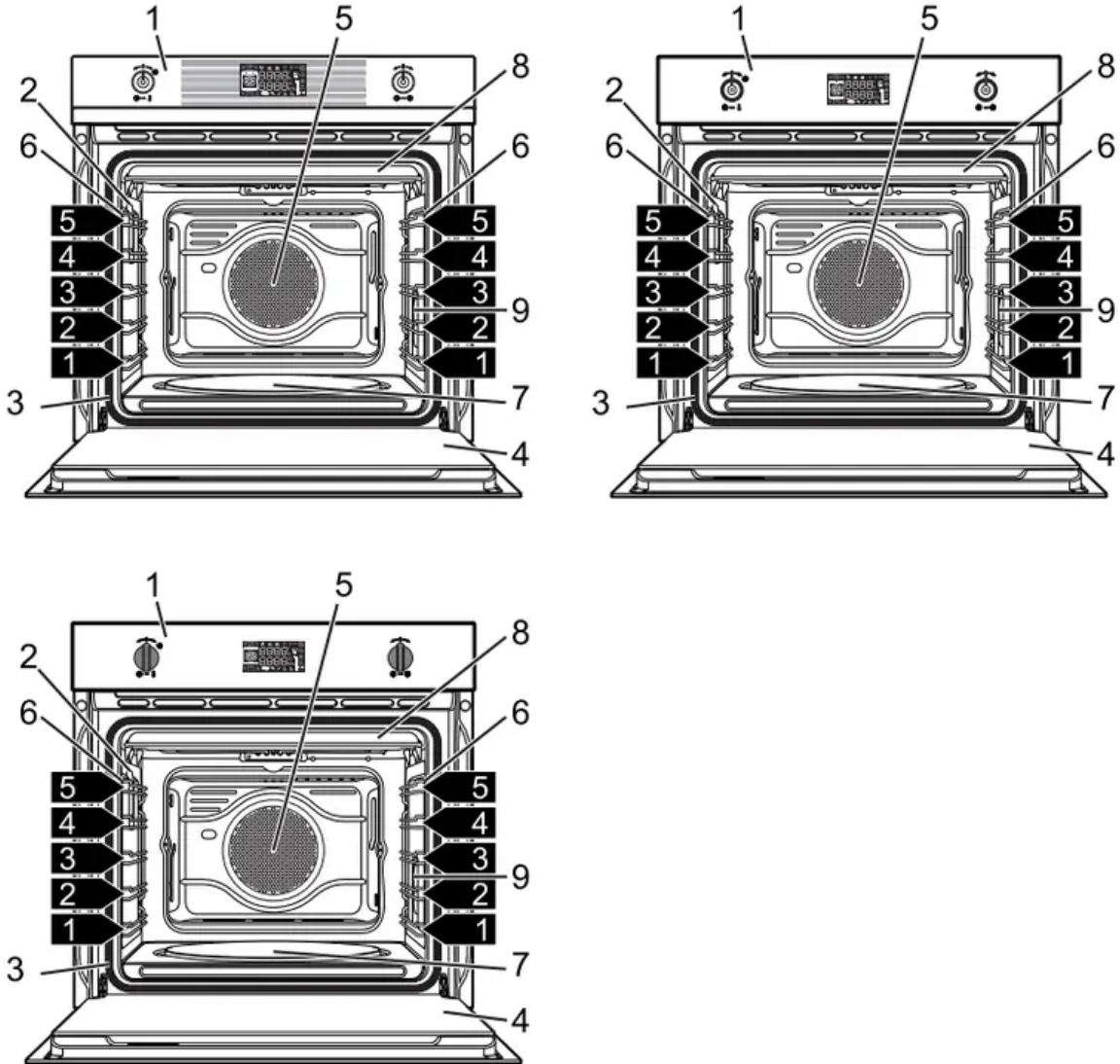

1 Control panel

2 Oven light

3 Seal

4 Door

5 Fan

6 Rack/tray support frames

7 Pizza plate (on some models only)

8 Roof liner (on some models only) 9 Light (on some models only)

## 1,2,3... Frame shelf

### Control panel

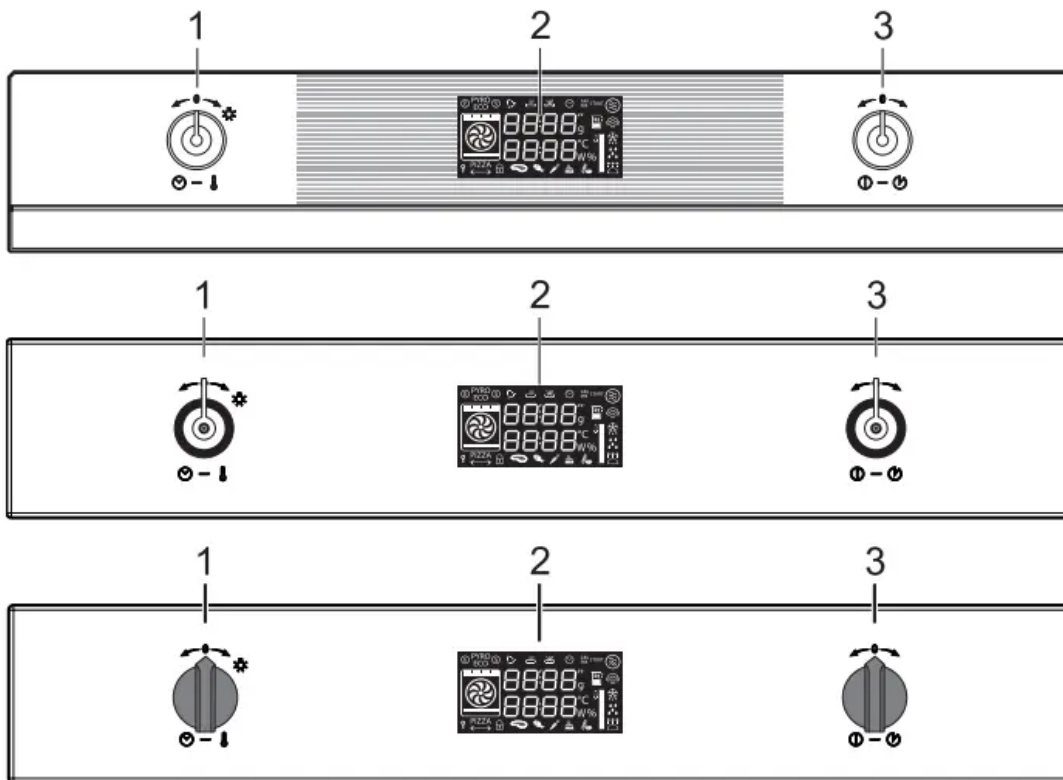

#### Temperature knob (1)

This knob allows you to select the cooking time and temperature, set programmed cooking and the current time as well as turn the light inside the oven on and off.

#### Display (2)

Displays the current time, the selected cooking temperature and function and any time set.

#### Function knob (3)

This knob allows you to turn the appliance on and off and select the cooking function

### Other Parts

#### Shelves



The appliance features shelves for positioning trays and racks at different heights. The insertion heights are indicated from the bottom upwards (see 2.1 General Description).

#### Cooling fan

The fan cools the oven and comes into operation during cooking. The fan causes a steady outflow of air from above the door which may continue for a brief period of time even after the appliance has been turned off.

### Interior lighting

The oven light comes on when the door is opened or any function is selected, except

for  ,  and  . Turn the temperature knob briefly to the right to activate or deactivate internal lighting

### Available accessories

#### Rack

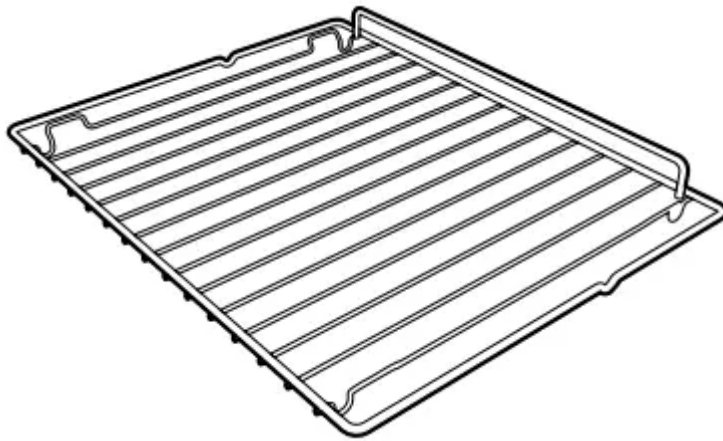

Useful for supporting containers with food during cooking.

#### Tray rack

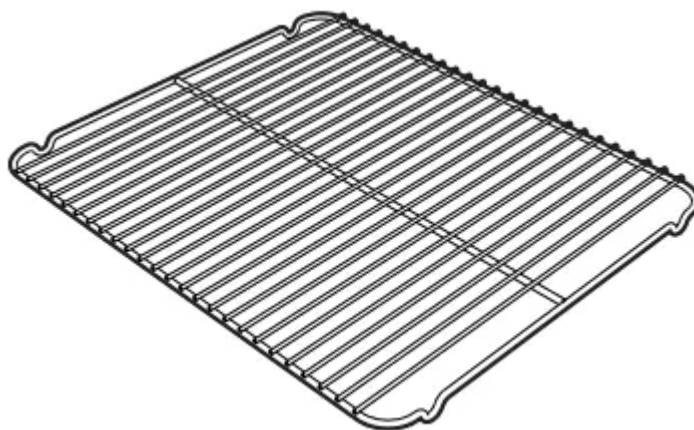

To be placed over the top of the oven tray; for cooking foods which may drip.

#### Oven Tray

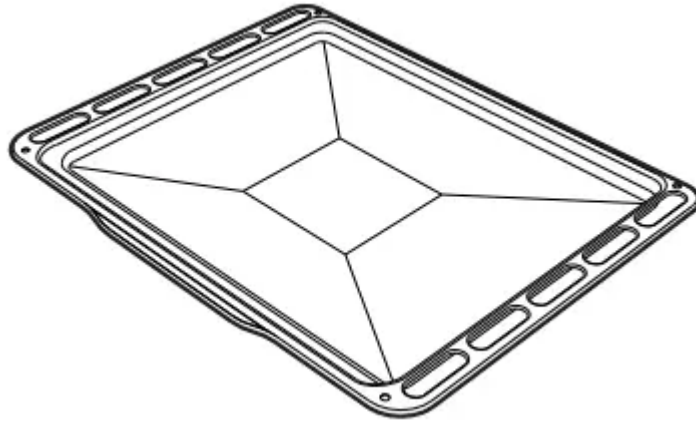

Useful for collecting fat from foods placed on the rack above.

**Deep tray**

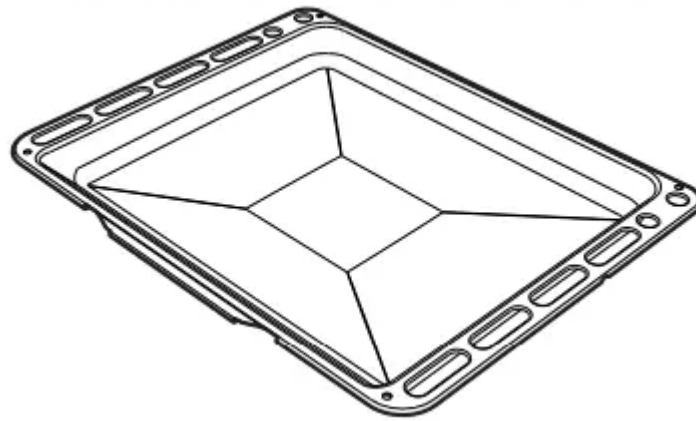

Useful for collecting fat from foods placed on the rack.

**Pizza plate**

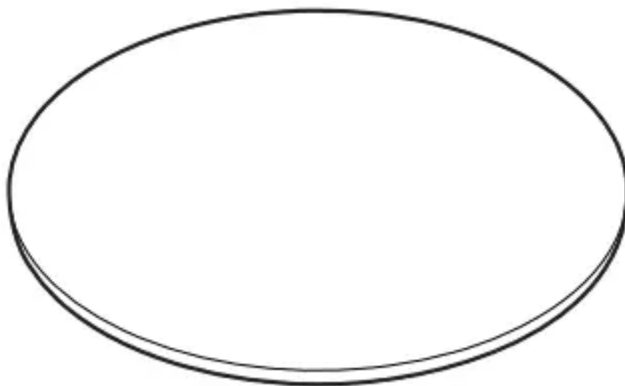

Specially designed for cooking pizza and similar dishes.

**Pizza spatula**

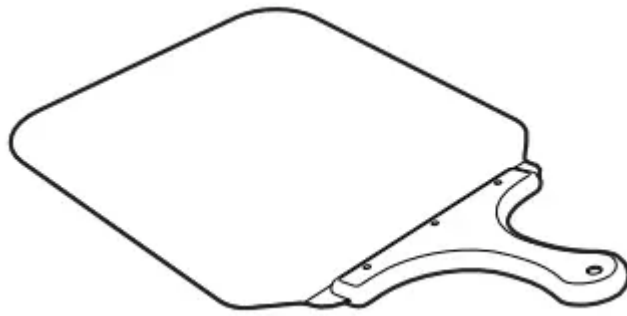

For easily placing the pizza on the pizza plate.

### **Pizza plate cover**

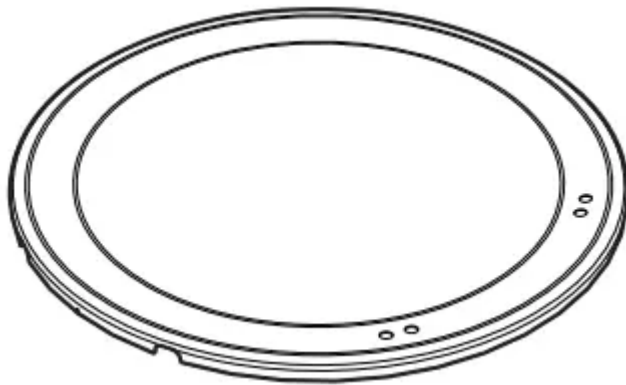

To be placed in the recess on the bottom of the oven, replacing the pizza plate when it is not being used.

## **Use**

### **Using the accessories**

#### **Racks and trays**

Racks and trays have to be inserted into the side guides until they come to a complete stop.

- The mechanical safety locks that prevent the rack from being taken out accidentally have to face downwards and towards the oven back.

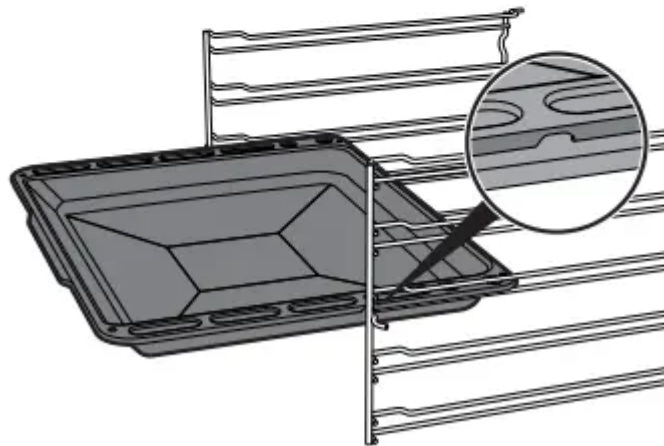
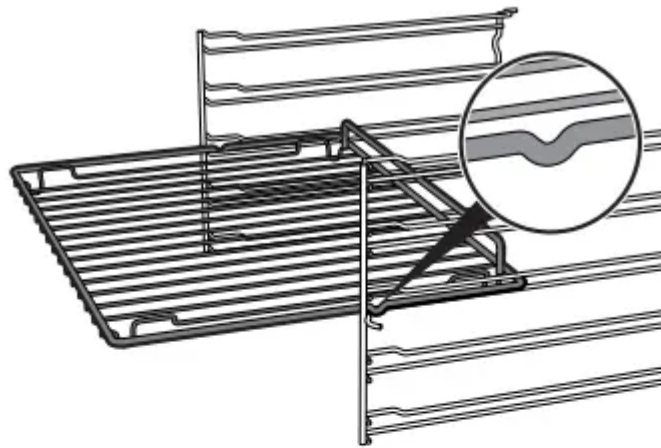

Gently insert racks and trays into the oven until they come to a stop.



Clean the trays before using them for the first time to remove any residues left by the manufacturing process.

### **Tray rack**

The tray rack has to be inserted into the tray. In this way fat can be collected separately from the food which is being cooked.

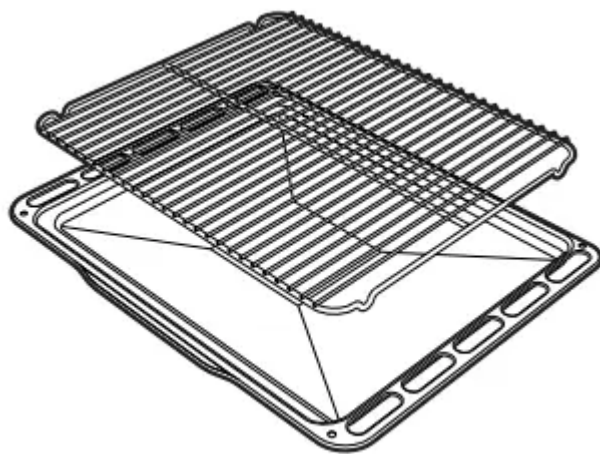

### Cover and pizza plate (on some models only)



#### **Improper use Risk of damage to surfaces**

- Do not use the pizza plate other than as described, for example do not use it on gas or glass ceramic hobs or in ovens which are not designed for this purpose.
- If you like oil on your pizza, it is best to add it after removal from the oven since oil stains on the pizza plate are unsightly and may reduce its efficiency.
- If the pizza plate is not in use, cover the bottom of the oven with the cover provided.

With the oven cold, remove the cover from the bottom and insert the pizza plate. Make sure that the plate is inserted correctly in the recess provided. For cooking, use the special function **PIZZA**

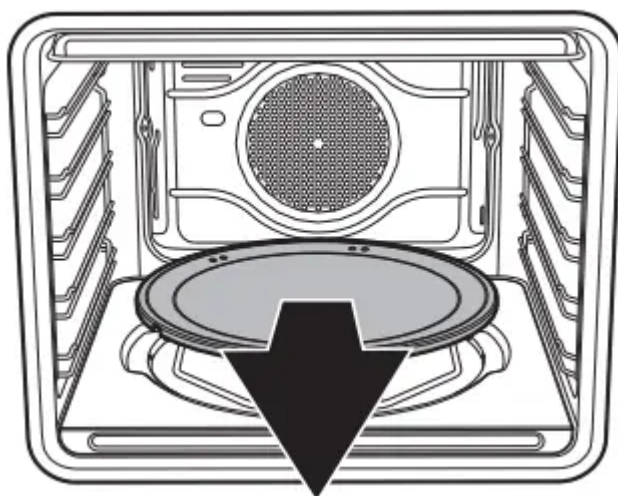

### Pizza spatula (on some models only)



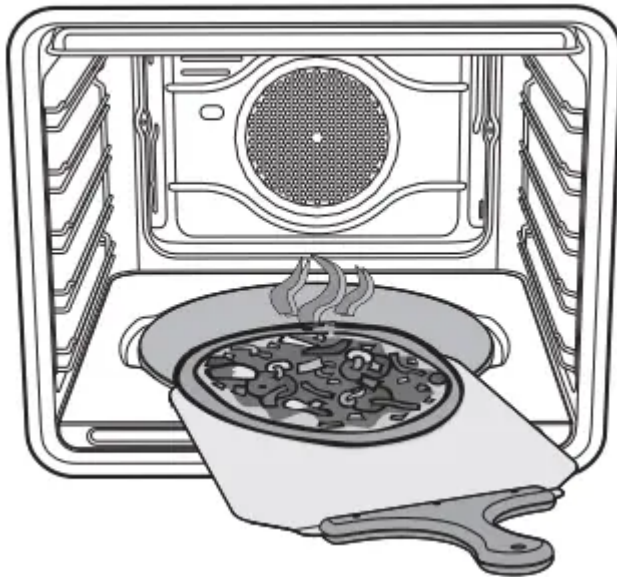

Always hold the pizza spatula by the handle to put food in and take it out of the oven.  
You are advised to dust the steel surface lightly with flour to make it easier to slide fresh products on and off, as they could stick to the steel due to their moisture content.



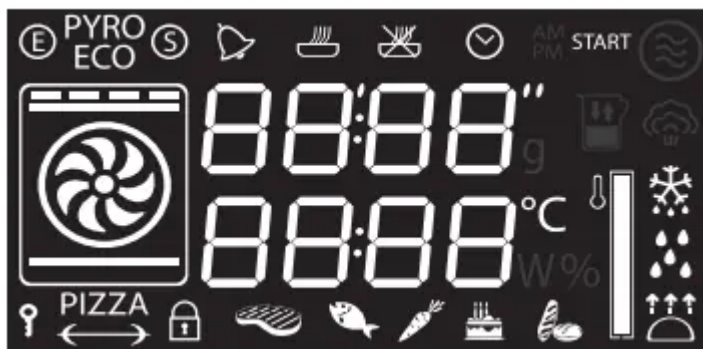

## Using the oven

### Display



-  Clock indicator light
-  Minute minder timer indicator light
-  Timed cooking with delayed start indicator light
-  Timed cooking indicator light
-  Child lock indicator light

 Showroom indicator light

 Eco logic indicator light

 Temperature level reached

## Operating modes

**Stand-by:** When no function is selected, the display shows the current time and the  symbol.



**ON:** When a function is activated, the display shows the parameters set such as temperature, duration and temperature reached.

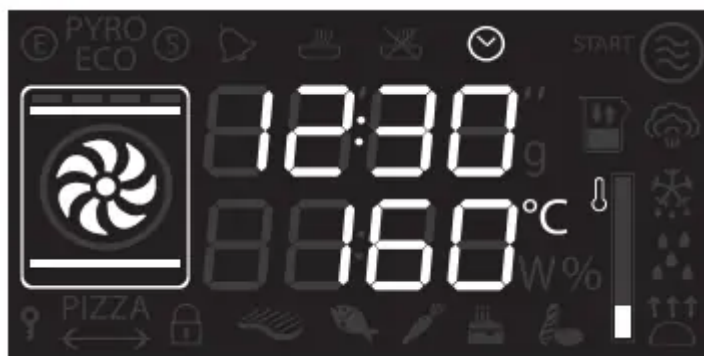

Each time the temperature knob is pressed during a function, the parameters will be cycled through in the following order. In all modes it is possible to modify the value by turning the temperature knob to the left or right. Keep the knob turned to produce a faster increase or decrease.



1. Temperature

2. Minute minder timer duration
3. Function duration
4. Programmed cooking duration (if timed cooking has been selected)
5. Time display

On the first use,  or after a power failure, will be flashing on the appliance's display. To be able to start any cooking function, the current time must be set.

1. Turn the temperature knob to set the displayed time (keep the knob turned to produce a faster increase or decrease).
2. Press the temperature knob.
3. Turn the temperature knob to set the minutes (keep the knob turned to produce a faster increase or decrease).
4. Press the temperature knob to finish adjustment.

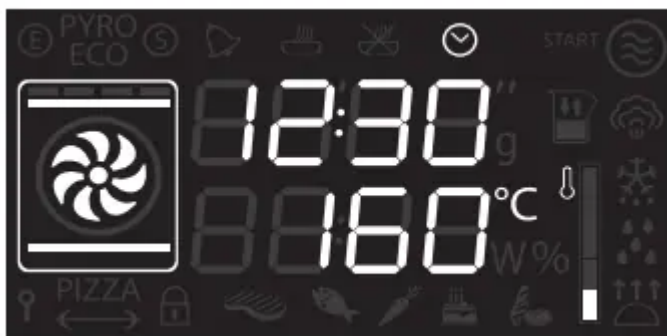

### Cooking functions



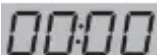

1. Select a traditional cooking function with the function knob.
2. Press the temperature knob if you wish to change the default temperature.
3. Turn the knob to set the temperature.
4. Press the function knob to start traditional cooking.

### Minute minder

1. Press the temperature knob once (twice if cooking is already in progress). The

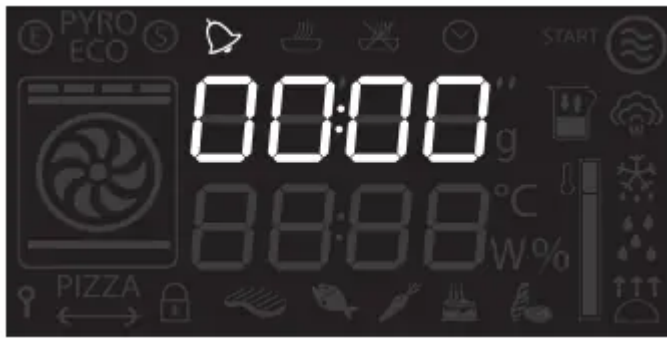
display shows  and the  indicator light flashes.





2. Turn the knob to set the duration (from 1 minute to 4 hours). After a few seconds, the  indicator light stops flashing and the countdown starts.

3. Select the required cooking function and wait for the buzzer to sound, indicating that the cooking time is over. The  indicator light flashes.

4. Turn the knob to select another minute minder. Or else press the temperature knob to stop the buzzer.

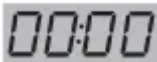
### Timed cooking

1. After selecting a cooking function and temperature, press the temperature knob three times. The display shows  and the  indicator light flashes.

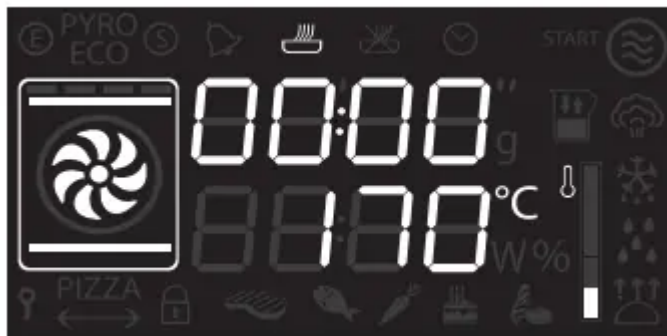

2. Turn the temperature knob right or left to set the cooking duration from 00:01 to 12:59. Keep the knob turned to produce a faster increase or decrease.

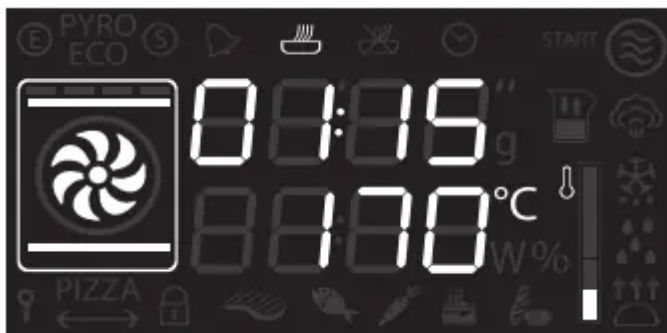



3. A few seconds after the required duration is set, the  indicator light stops flashing and timed cooking starts.

4. At the end of the cooking time STOP appears on the display and a buzzer sounds that can be deactivated by pressing the temperature knob



### Modifying the data set during timed cooking

During operation, it is possible to modify timed cooking duration:

1. When the  indicator light is steady and cooking is in progress inside the appliance, press the temperature knob twice. The  indicator light starts flashing.
2. Turn the temperature knob right or left to alter the pre-set cooking time.

### Programmed cooking



1. After selecting a cooking function and temperature, press the temperature knob three times. The display shows  and the  indicator light flashes.

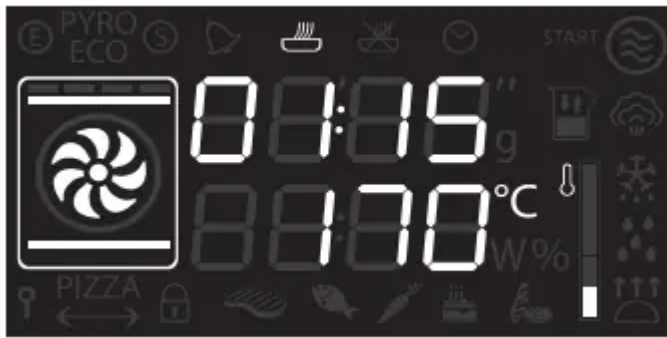

2. Turn the knob right or left to set the cooking duration from 00:01 to 12:59. Keep the knob turned for a fast increase or decrease.



3. Press the temperature knob a fourth time. The  indicator light flashes. Turn the knob right or left to set the cooking end time.

4. After a few seconds the  and  indicator lights stop flashing. The appliance waits for the set start time









5. At the end of the cooking time STOP appears on the display and a buzzer sounds that can be deactivated by pressing the temperature knob.



### Modifying the data set during programmed cooking

During operation, it is possible to modify programmed cooking duration:

1. When the  and  indicator lights are lit steadily and the appliance is waiting for cooking to start, press the temperature knob twice. The  indicator light starts flashing.
2. Turn the temperature knob right or left to alter the pre-set cooking time.
3. Press the temperature knob again. The  indicator light switches off and the  indicator light starts flashing. The display shows the cooking end time.
4. Turn the temperature knob right or left to delay the cooking end time.
5. After a few seconds the  and  indicator lights stop flashing and programmed cooking restarts its operation with the new settings.

## Cooking advice

### General advice

- Use a fan assisted function to achieve consistent cooking at several levels.
- It is not possible to shorten cooking times by increasing the temperature (the food could be overcooked on the outside and undercooked on the inside).

### Advice for cooking meat

- Cooking times vary according to the thickness and quality of the food and to consumer taste.
- Use a meat thermometer when roasting meat, or simply press on the roast with a spoon. If it is hard, it is ready; If not, it needs another few minutes cooking.

### Advice for cooking with the Grill and the Fan with grill

- Meat can be grilled even when it is put into the cold oven or into the preheated oven if you wish to change the effect of the cooking.
- With the Fan with grill function, we recommend that you preheat the oven before grilling.
- We recommend placing the food at the centre of the rack.

### Advice for cooking desserts/pastries and biscuits

- Use dark metal moulds: They help to absorb the heat better.
- The temperature and the cooking time depend on the quality and consistency of the dough.

- To check whether the dessert is cooked right through: At the end of the cooking time, put a toothpick into the highest point of the dessert. If the dough does not stick to the toothpick, the dessert is cooked.
- If the dessert collapses when it comes out of the oven, on the next occasion reduce the set temperature by about 10°C, selecting a longer cooking time if necessary.

### Advice for defrosting and proving

- Place frozen foods without their packaging in a lidless container on the first shelf of the oven.
- Avoid overlapping the food.
- To defrost meat, use the rack placed on the second level and a tray on the first level. In this way, the liquid from the defrosting food drains away from the food.
- The most delicate parts can be covered with aluminium foil.
- For successful proving, a container of water should be placed in the bottom of the oven.

### To save energy

- Stop cooking a few minutes before the time normally used. Cooking will continue for the remaining minutes with the heat which has accumulated inside the oven.
- Reduce any opening of the door to a minimum to avoid heat dispersal.
- Keep the inside of the appliance clean at all times.
- (Where fitted) When it is not being used, remove the pizza plate and put the cover back in its slot.

## Special functions and automatic programs

### Timed defrosting

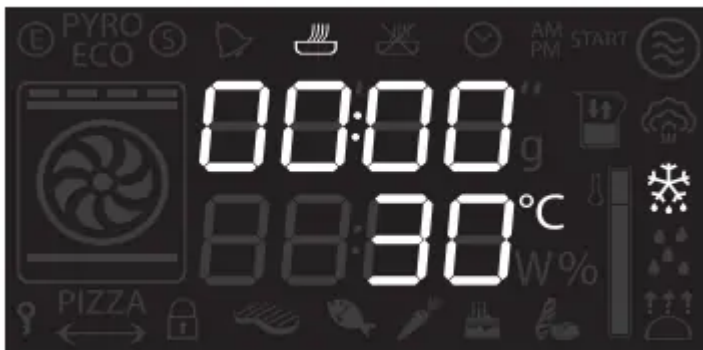

1. Place the food inside the oven.

2. Select the timed defrosting function, indicated by the  symbol, using the function knob.
3. Press the temperature knob to set the duration.
4. Turn the knob to adjust the value (from 5 seconds to 99 minutes).
5. Press the function knob to start defrosting.
6. At the end, the word STOP will be displayed.

### Proving



1. Position the dough for proving on the second shelf.
2. Press the function knob to select and activate proving.
3. At the end of preheating, the text "START" flashes.
4. Put the food to cook into the oven and press the function knob to start cooking.

### Shabbat







1. Press the function knob to select the Shabbat function.
2. Press the temperature knob.
3. Turn the temperature knob to change the re-heating time.
4. Press the function knob to confirm the settings and start the Shabbat function.
5. Once completed press and hold the function knob down for at least 3 seconds to turn the appliance off.

## Defrosting by weight



1. Place the food inside the oven.
2. Press the function knob to select defrosting by weight, marked by “dE00” and the illuminated food symbols.
3. Turn the function knob to select the type of food to defrost.
4. Turn the temperature knob to select the weight (in grams) of the food to defrost.
5. Press the function knob to confirm the parameters and start defrosting.
6. At the end, the word STOP will be displayed.

Preset parameters:

	dE	Type	Weight (g)	Time (min)
01		Meat	500	105
02		Fish	400	40
03		Fruit	300	45
04		Bread	300	20

## Automatic programs



The automatic cooking programs are divided by the type of food to be cooked.

1. Press the function knob to select cooking with automatic programs.
2. Turn the function knob to select the required program (see Automatic programs table).

#### MEATS (01 - 05)

Subcategory	Weight (g)	Level	Function	Temp. (°C)	Time (minutes)
01 Roast beef	1000	2	Circulaire	200	50
02 Pork loin	1000	2	Turbo	190	75
03 Lamb	1000	2	Turbo	190	100
04 Veal	1000	2	Fan assisted	190	65
05 Roast chicken	1000	2	Turbo	200	64

#### FISH (06 - 07)

Subcategory	Weight (g)	Level	Function	Temp. (°C)	Time (minutes)
06 Fresh fish	500	2	Fan assisted	160	35
07 Frozen fish	500	2	Circulaire	160	45

#### VEGETABLES (08 - 10)

Subcategory	Weight (g)	Level	Function	Temp. (°C)	Time (minutes)
08 Mixed grilled	500	4	Grill	250	25
09 Roasted	1000	2	Circulaire	200	45
10 Roast potatoes	1000	2	Turbo	220	40

#### DESSERTS (11 - 13)

Subcategory	Weight (g)	Level	Function	Temp. (°C)	Time (minutes)
11 Biscuits	600	2	Turbo	160	18
12 Muffins	500	2	Circulaire	160	18
13 Tart	800	2	Static	170	40

## BREAD - PIZZA - PASTA (14-20)

	Subcategory	Weight (g)	Level	Function	Temp. (°C)	Time (minutes)
14	Leavened bread	1000	2	Circulaire	200	30
15	Pan baked pizza	1000	1	Fan assisted	280	7
16	Stone baked pizza	500	1	Fan assisted	280	4
17	Pasta bake	200	1	Static	220	40
18	Lasagne	200	1	Static	230	35
19	Paella	500	2	Fan assisted	190	25
20	Quiche	1000	1	Static	200	40

## Secondary menu

### Child Lock mode:

This mode allows the appliance to lock the controls automatically after one minute of normal operation without any intervention from the user.



During normal operation it is indicated by the  indicator light coming on. To release the lock temporarily during cooking, hold the temperature knob down for 5 seconds. One minute after the last setting the lock will become active again.

**Showroom mode (for exhibitors only):** This mode allows the appliance to deactivate all heating elements, while keeping the control panel active.



To use the appliance normally, set this mode to **OFF**.



**Low Power mode:** This mode allows the appliance to limit the power used. Indicated for use of multiple appliances at the same time on circuits with limited maximum power.

**HI:** normal power.



**LO:** low power



**Keep Warm Mode (some models only):**

This mode allows the appliance to keep cooked food warm (at low temperatures) for around an hour after cooking finishes with a cooking cycle for which a duration has been set (if this is not manually interrupted).



### Light timing mode

For greater energy savings, the light is automatically deactivated one minute from the start of cooking.



To stop the appliance from automatically deactivating the light after one minute, set this mode to OFF.



## Cleaning and maintenance

### Cleaning the surfaces

To keep the surfaces in good condition, they should be cleaned regularly after use. Let them cool first.

### Ordinary daily cleaning

Always use only specific products that do not contain abrasives or chlorine-based acids. Pour the product onto a damp cloth and wipe the surface, rinse thoroughly and dry with a soft cloth or a microfibre cloth.

### Food stains or residues

Do not use metallic sponges or sharp scrapers as they will damage the surfaces. Use ordinary non-abrasive products with the aid of wooden or plastic utensils if necessary. Rinse thoroughly and dry with a soft cloth or a microfibre cloth. Do not allow residues of sugary foods (such as jam) to set inside the oven. If left to set for too long, they might damage the enamel lining of the oven.

### Removing the door

For easier cleaning, the door can be removed and placed on a canvas. To remove the door proceed as follows: 1. Open the door completely and insert two pins into the holes on the hinges indicated in the figure.

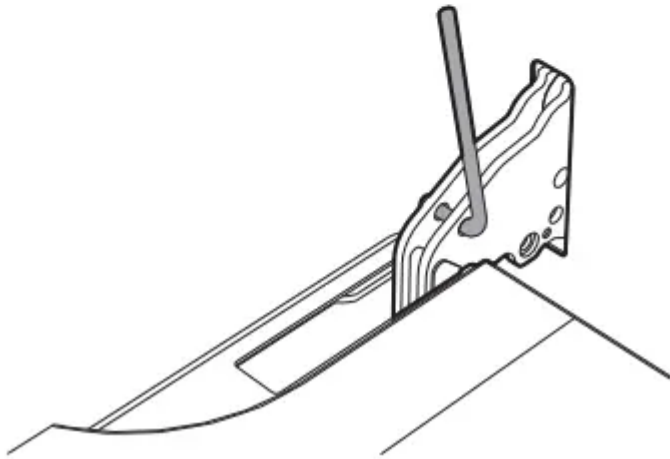
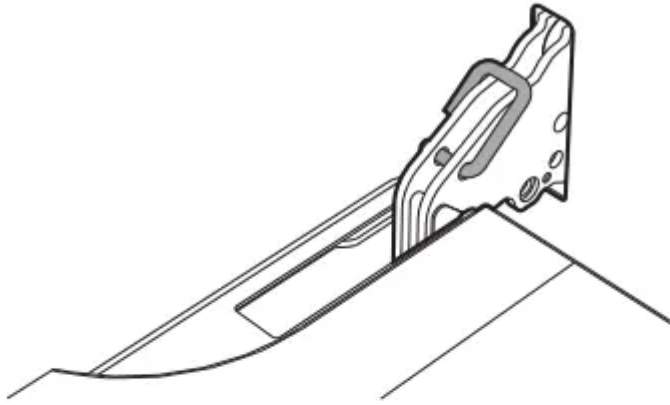

2. Grasp the door on both sides with both hands, lift it forming an angle of around 30° and remove it.

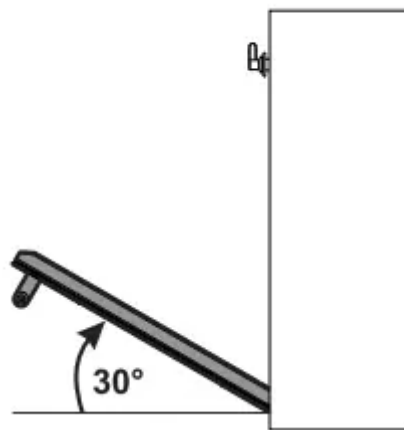

3. To reassemble the door, put the hinges in the relevant slots in the oven, making sure that grooved sections **A** are resting completely in the slots. Lower the door and once it is in place remove the pins from the holes in the hinges.

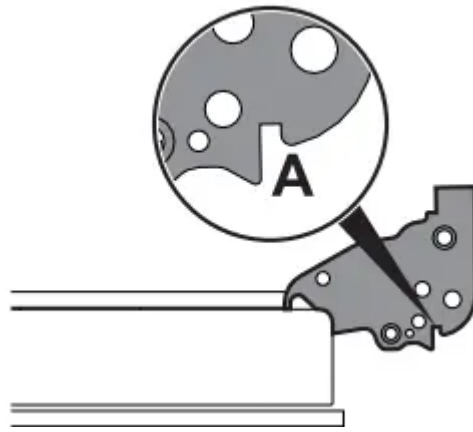

### Cleaning the door glazing

The glass in the door should always be kept thoroughly clean. Use absorbent kitchen roll. In case of stubborn dirt, wash with a damp sponge and an ordinary detergent.

### Removing the internal glass panes

For easier cleaning the door internal glass panes can be disassembled.

1. Remove the internal glass pane by pulling the rear part gently upwards, following the movement indicated by the arrows **(1)**.
2. Then, pull the front part upwards **(2)** In this way, the 4 pins attached to the glass detach from their housings in the oven door.

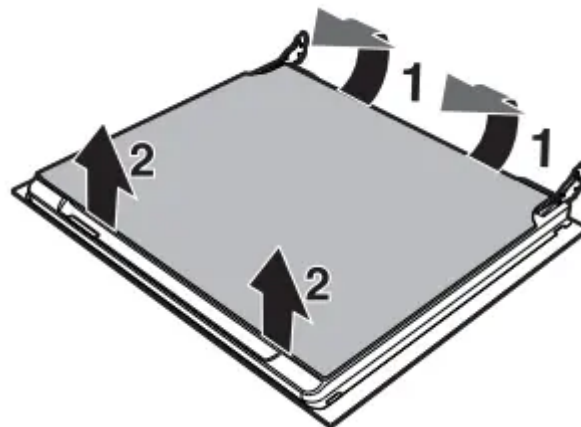

3. Some models have an intermediate glass pane. Remove the intermediate glass pane by lifting it upwards

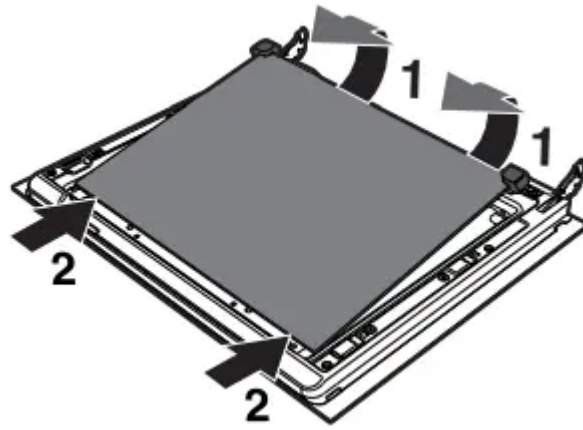

4. Clean the external glass pane and the panes previously removed. Use absorbent kitchen roll. In case of stubborn dirt, wash with a damp sponge and neutral detergent.

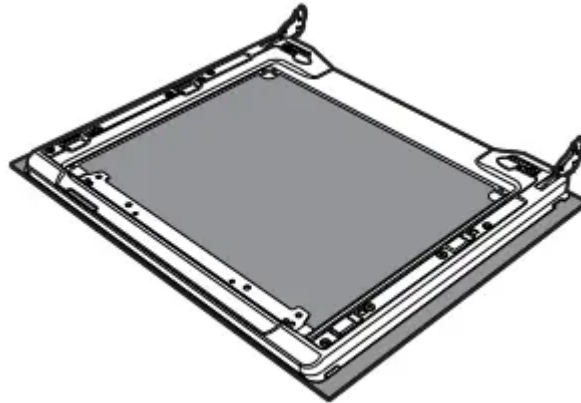

5. Refit the panes in the reverse order in which they were removed.
6. Reposition the internal glass pane. Take care to centre and insert the 4 pins into their housings in the oven door by applying slight pressure.

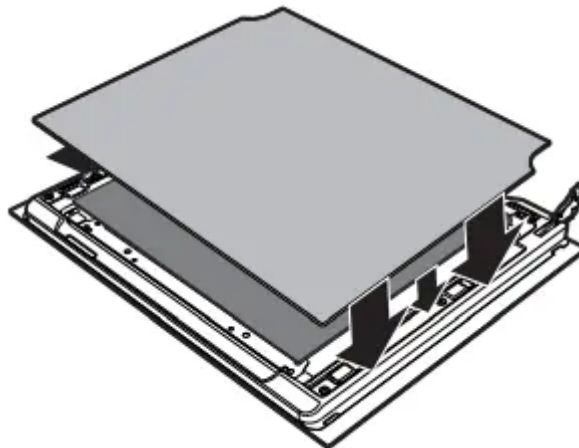

## Cleaning the inside of the oven

For the best oven upkeep, clean it regularly after having allowed it to cool. Take out all removable parts. Clean the oven racks with warm water and non-abrasive detergent. Carefully rinse and dry damp parts.



## Removing racks/trays support frames

Removing the guide frames enables the sides to be cleaned more easily. This operation should be performed each time the automatic cleaning cycle is used (on some models only).

To remove the guide frames: Pull the frame towards the inside of the oven to unhook it from its groove A, then slide it out of the seats B at the back.

When cleaning is complete, repeat the above procedures to put the guide frames back in.

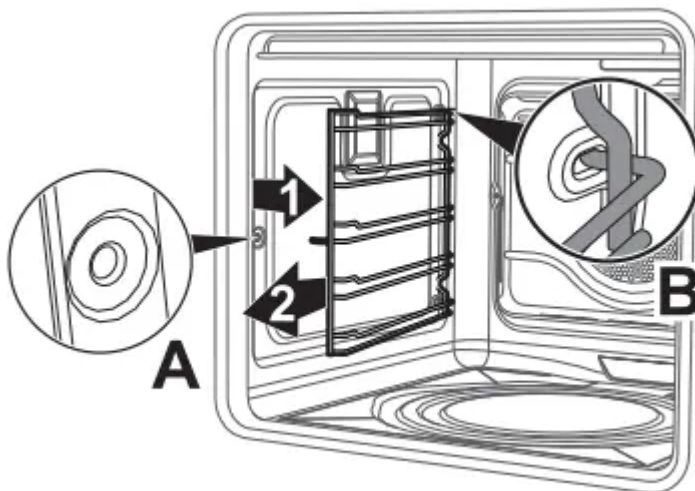

## On pizza models only:

Remove in sequence the pizza plate cover (1) and the base (2) on which it is placed. The base has to be lifted a few millimetres, then pulled outwards.

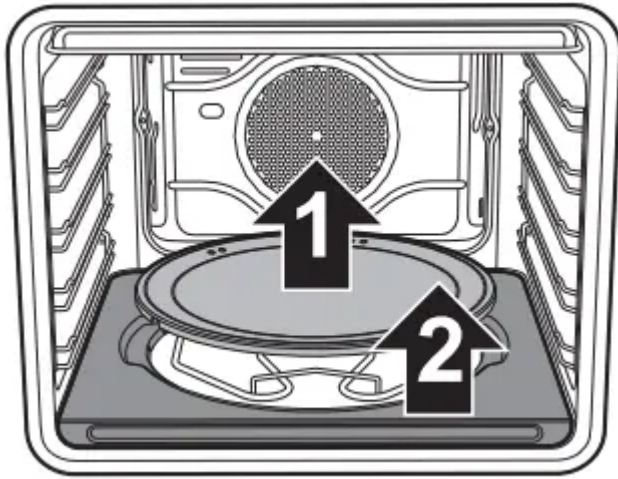

Lift the end of the lower heating element (3) a few centimetres and clean the oven base.

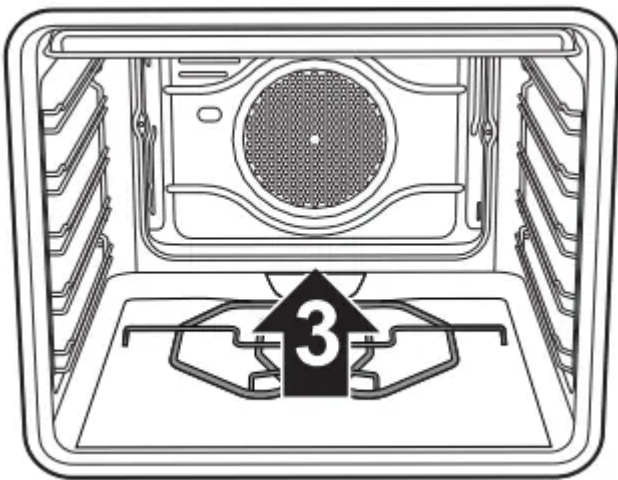

Put the pizza plate base back in place, pushing it in until it hits the back of the oven, and push it down so that the heating element plate is embedded into the base itself.

### **Cleaning the pizza plate**

The pizza plate should be washed separately according to the following instructions:

**Pyrolytic models:** Leave the pizza stone inside and activate the pyrolysis function, then at the end, when the stone has cooled down to lukewarm, wipe it with a damp microfibre cloth to remove any residues.

**Multifunction models:** The stone must be cleaned after every use. Do not heat it again if it has any encrustations. To clean, pour 50 cc of vinegar onto the stone, leave it to act for 10 minutes, then remove it by wiping with a metallic mesh or abrasive sponge. Rinse with water then leave to dry.

- Before cleaning, remove any dirt burnt onto the stone with the aid of a metal spatula or a scraper of the kind used for cleaning glass-ceramic hobs.
- For best results, the stone must still be warm; otherwise, wash it in hot water.

- Use metal mesh sponges or abrasive scotch-brite pads, dipped in lemon or vinegar.
- Never use detergents.
- Never wash in the dishwasher.
- Never leave the stone to soak.
- The damp stone must not be used for a least 8 hours after the end of the cleaning procedures.
- Over time, slight cracks may appear on the surface of the stone. This is due to the normal expansion caused by high temperatures of the enamel coating the stone.

## Extraordinary maintenance

### Replacing the internal light bulb

1. Completely remove all accessories from inside the oven.
2. Remove the racks/trays support frames.
3. Remove the bulb cover using a tool (e.g. a screwdriver).

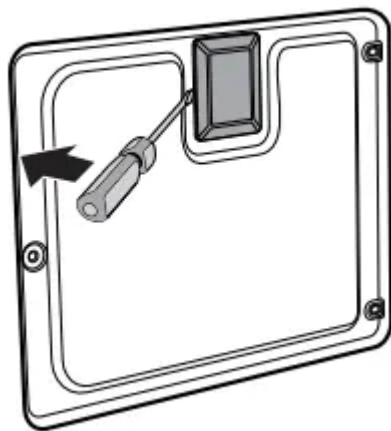

4. Slide out and remove the lamp.

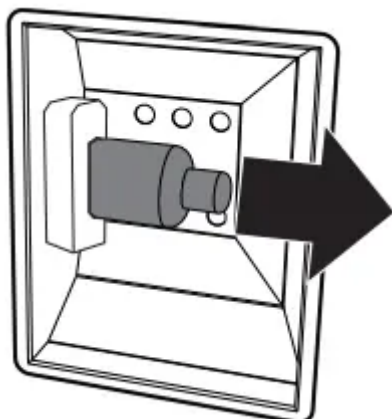

5. Replace the lamp with one of the same type (40W).
6. Refit the cover correctly, so that the moulded part of the glass is facing the door.
7. Press the cover completely down so that it attaches perfectly to the bulb support

### **What to do if...**

The display is completely off:

- Check the mains power supply.
- Check whether an omnipolar switch upstream of the appliance supply line is in the “ON” position.

The appliance does not heat up:

- Check whether it has been set in “showroom” mode (for further details see “Secondary menu”).

The controls do not respond:

- Check whether it has been set in “child lock” mode (for further details see “Secondary menu”).

The cooking times are longer than those indicated in the table:

- Check whether it has been set in “low power” mode (for further details see “Secondary menu”).

After the (pyrolytic) automatic cleaning cycle it is not possible to select a function:

- Verify whether the door lock has deactivated. If it has not, the oven has a safety device that does not allow functions to be selected while the door lock is active. This is because the temperature inside the oven is still too high to permit any type of cooking.

The display shows “ERR4”:

- The door lock has not properly attached to the door. This might be because the door was accidentally opened during the door lock activation. Switch the oven off and on again, waiting a few minutes before selecting a new cleaning cycle.

If the door is opened during a fan assisted function, the fan stops:

- This is not a fault. It is a normal operation of the appliance, useful when cooking foods in order to avoid excessive heat escaping. When the door is closed, the oven will return to normal operation.

## **Installation**

### **Electrical connection**

### **General information**

Check the grid characteristics against the data indicated on the plate. The identification plate bearing the technical data, serial number and brand name is visibly positioned on the appliance. Do not remove this plate for any reason. The appliance works at 220-240 V~. Use a H05V2V2-F type three-core cable (3 x 1.5 mm<sup>2</sup> cable, referring to the cross section of the internal conductor). Perform the ground connection using a wire that is 20 mm longer than the to other wires.

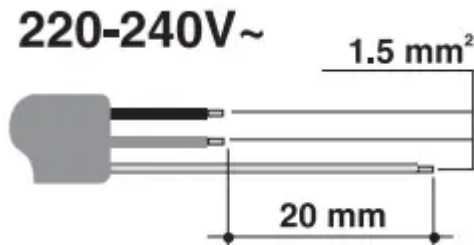

### **Fixed connection**

Fit the power line with an omnipolar circuit breaker in compliance with installation regulations. The circuit breaker should be located near the appliance and in an easily reachable position.

### **Connection with plug and socket**

Make sure that the plug and socket are of the same type. Avoid using adapters and shunts as these could cause overheating and a risk of burns.

### **Cable replacement**

1. Unscrew the rear casing screws and remove the casing to access the terminal board.
2. Replace the cable.
3. Make sure that the cables (for the oven or any hob) follow the best route in order to avoid any contact with the appliance.

### **Positioning**

#### **Fastening bushings**

Remove the bushing covers inserted on the oven front.

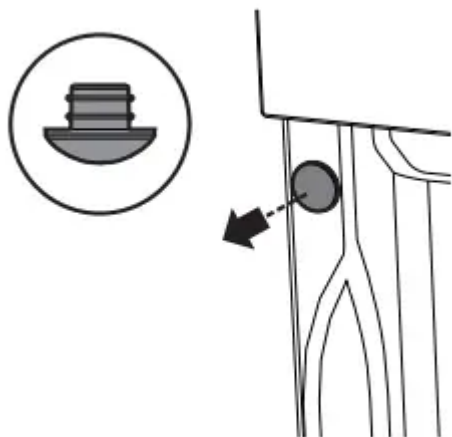

Mount the appliance into the recess.

Secure the appliance to the piece of furniture using screws.

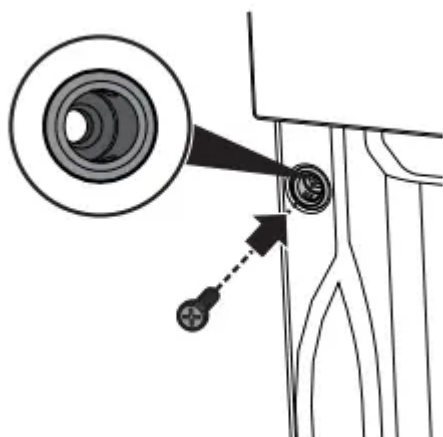

Cover the bushings with the covers removed previously.

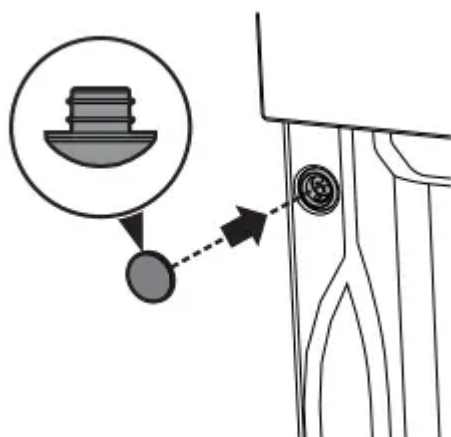

**Appliance overall dimensions (mm)**

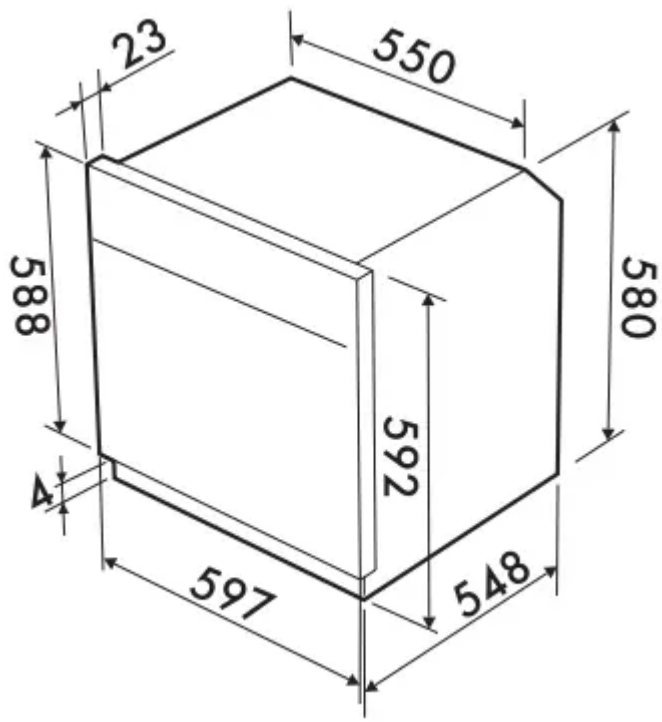

Mounting under worktops (mm)



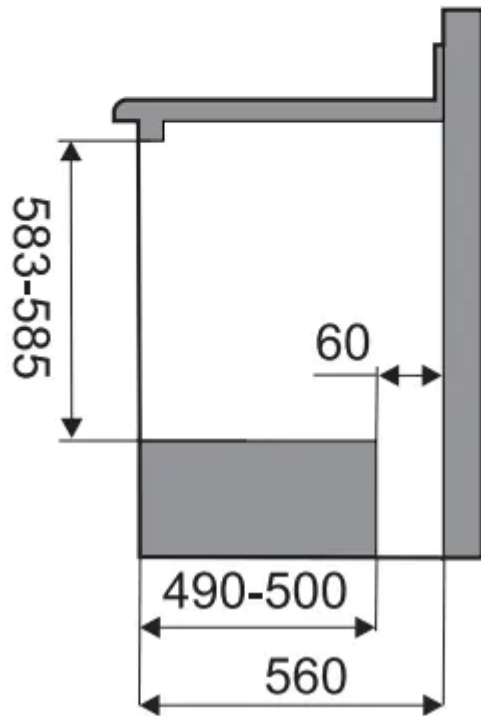
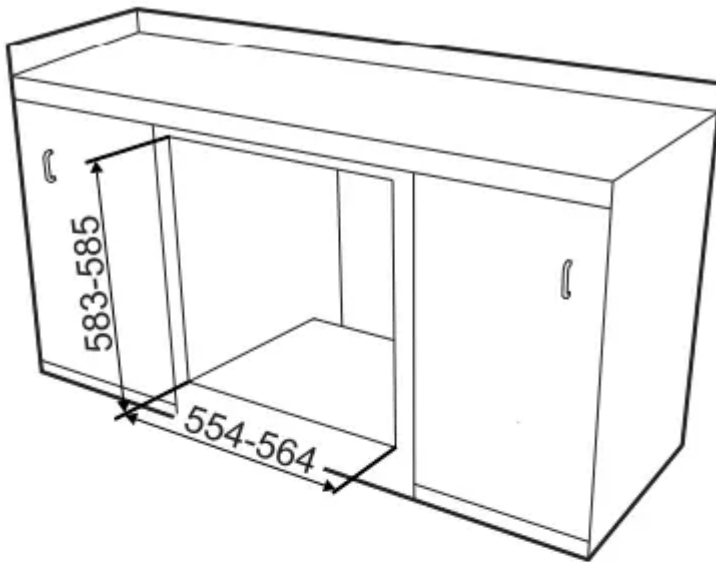

Mounting into a column (mm)



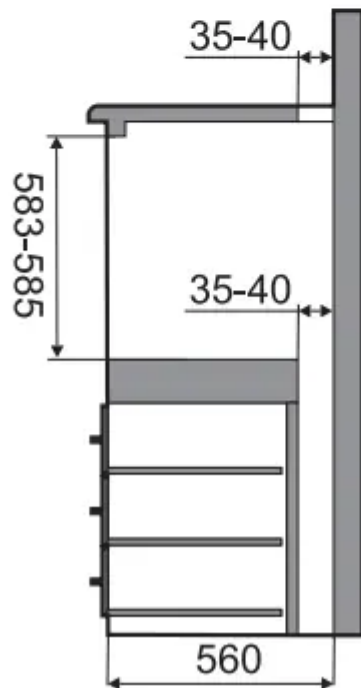
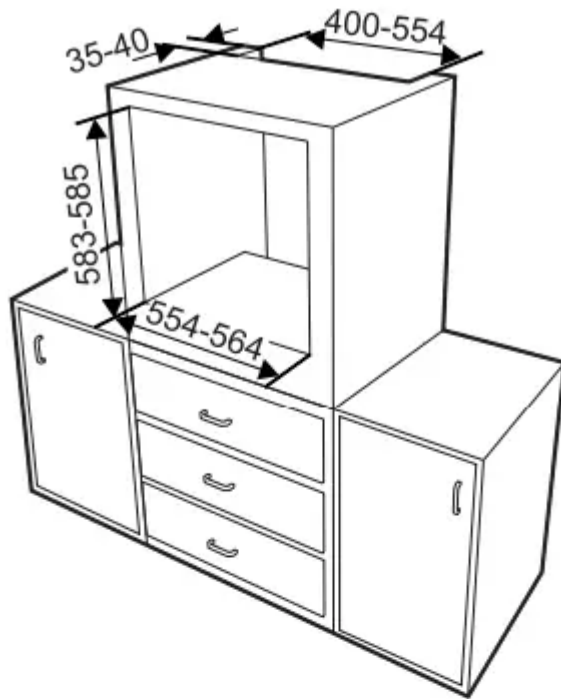

### Warning

This content is compiled from multiple sources and is provided for reference purposes only. It may not be complete or fully applicable to all situations. If you are unable to resolve your issue, please contact the product manufacturer or an authorized service provider for official support.