

# Operations

## User interface

<p><b>01</b> <b>Home</b> <b>screen</b></p>	
	<p>1. Apps &amp; Widgets</p> <ul style="list-style-type: none"> <li>◦ Tap a desired app or widget to launch it.</li> <li>◦ Tap and hold an app or widget to enter Edit mode. A grid appears. In Edit mode, you can drag and drop an app or widget to a new position on the grid. When you move the app or widget to a new grid location, the location turns blue if it is available. If it is not available, it turns red.</li> <li>◦ You can add an app or widget that has been removed from the Apps list.</li> </ul> <p>2. Status bar</p> <ul style="list-style-type: none"> <li>◦ Displays the status of various functions. (Refer to the following Icon descriptions table.)</li> </ul>

<p><b>02 Task bar</b></p>												
		<table border="1"> <tr> <td data-bbox="1072 1653 1171 1751"> <p><b>01</b> Microphone</p> </td> <td data-bbox="1171 1653 1321 1751"> <p>Tap to turn on or off the voice recognition function. The microphone icon turns red when it is turned off.</p> </td> </tr> <tr> <td data-bbox="1072 1751 1171 1792"> <p><b>02</b> Menu</p> </td> <td data-bbox="1171 1751 1321 1792"> <p>Tap to display the menus available.</p> </td> </tr> <tr> <td data-bbox="1072 1792 1171 1908"> <p><b>03</b> Home</p> </td> <td data-bbox="1171 1792 1321 1908"> <ul style="list-style-type: none"> <li>• Tap to open the Home screen.</li> <li>• Tap and hold to open the Task Manager. See the Task Manager section for details.</li> </ul> </td> </tr> <tr> <td data-bbox="1072 1908 1171 1944"> <p><b>04</b> Return</p> </td> <td data-bbox="1171 1908 1321 1944"> <p>Tap to return to the previous screen.</p> </td> </tr> <tr> <td data-bbox="1072 1944 1171 1980"> <p><b>05</b> Notification</p> </td> <td data-bbox="1171 1944 1321 1980"> <p>Tap to display the Quick Panel.</p> </td> </tr> </table>	<p><b>01</b> Microphone</p>	<p>Tap to turn on or off the voice recognition function. The microphone icon turns red when it is turned off.</p>	<p><b>02</b> Menu</p>	<p>Tap to display the menus available.</p>	<p><b>03</b> Home</p>	<ul style="list-style-type: none"> <li>• Tap to open the Home screen.</li> <li>• Tap and hold to open the Task Manager. See the Task Manager section for details.</li> </ul>	<p><b>04</b> Return</p>	<p>Tap to return to the previous screen.</p>	<p><b>05</b> Notification</p>	<p>Tap to display the Quick Panel.</p>
<p><b>01</b> Microphone</p>	<p>Tap to turn on or off the voice recognition function. The microphone icon turns red when it is turned off.</p>											
<p><b>02</b> Menu</p>	<p>Tap to display the menus available.</p>											
<p><b>03</b> Home</p>	<ul style="list-style-type: none"> <li>• Tap to open the Home screen.</li> <li>• Tap and hold to open the Task Manager. See the Task Manager section for details.</li> </ul>											
<p><b>04</b> Return</p>	<p>Tap to return to the previous screen.</p>											
<p><b>05</b> Notification</p>	<p>Tap to display the Quick Panel.</p>											

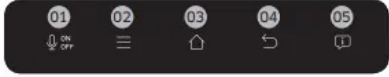

## Fridge Manager

To access Fridge Manager, swipe the Home screen to the left, and then tap the Fridge Manager widget.

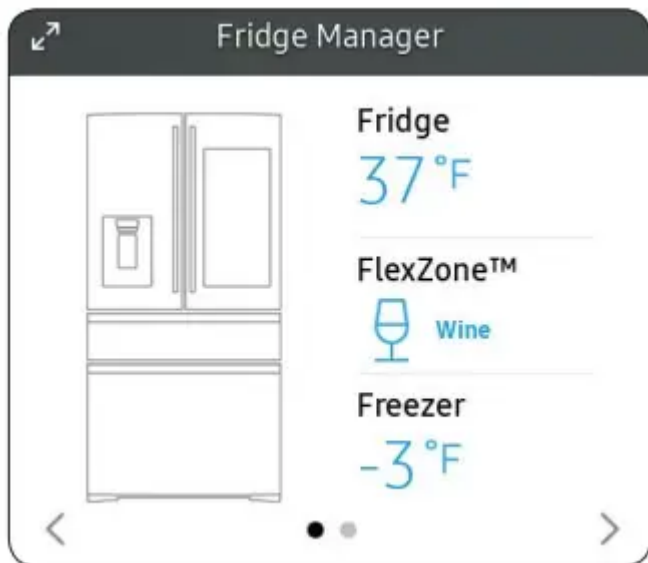

- Tap < or > on the bottom of the widget to move between pages.
- On the first page, you can check the current temperatures or modes of each compartment as well as active special functions.
- Tap the first page to open the Fridge Manager for detailed settings. On the second page, you can check the filter status.
- Tap Buy Filter on the second page to open the website where you can purchase a water filter.

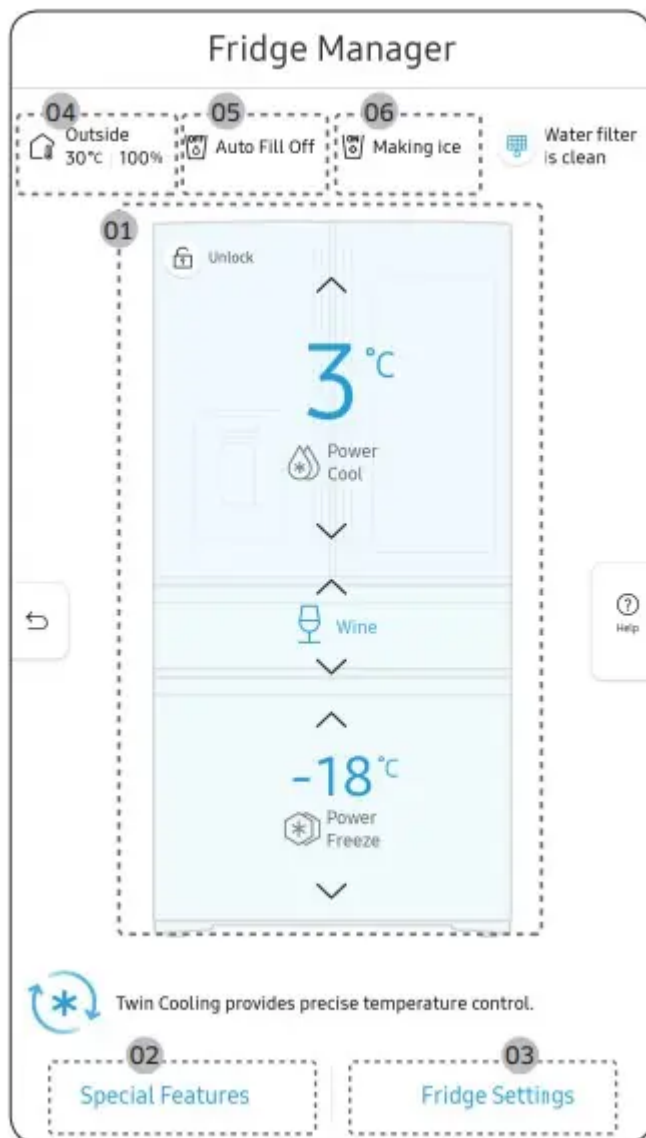



The Fridge Manager is a graphical representation of your refrigerator. The top half represents the refrigerator compartment, the bottom left the freezer compartment, and the bottom right the FlexZone. The temperature or mode settings for each are displayed over each section. Fridge Manager At a Glance

- 01 Temperature Change the set temperature in the fridge, freezer, and FlexZone. You can also turn on and turn off the refrigerator's Power Cool function and the freezer's Power Freeze function. - Power Freeze speeds up the freezing process at maximum fan speed. The freezer keeps running at full speed for several hours and then returns to the previous temperature. - To freeze large amounts of food, activate Power Freeze at least 20 hours before putting food in the freezer.  
**NOTE** Using Power Freeze increases power consumption. Make sure you turn it off so the freezer returns to its previous temperature if you do not need it any longer.
- 02 Special Features View a short explanation of some of the refrigerator's special features.

- 03 Fridge Settings Change many of the fridge's settings including settings for ice making, the door alarm, and the temperature units (°F or °C). See the next page for details.
- 04 External Conditions Displays the external (ambient) temperature and humidity.  
**NOTE** The displayed conditions may differ from the actual temperature and humidity.
- 05. Auto Water Fill Status Displays the status of the Auto Water Fill function.
- 06. Ice Maker Status Displays the operation status of the Ice Maker.

**NOTE**

- Also displayed is the Ice Maker off (ice making off) indicator at the top, center. When the indicator displays Ice Maker off, the refrigerator's ice maker is turned off.
- If the ice maker is turned off, it will turn on if you press and hold the ice lever for more than 5 seconds.

Ice Maker	Turns the icemaker on and off. Tap and drag the button to turn on or off. Note that if the ice bucket is full of ice, the refrigerator does not start making ice when you turn on the icemaker, but displays the Ice Full indicator on the main screen. If you hold down the dispenser lever for 5 seconds, the Ice Maker Off status changes to Making ice.
Auto Water Fill	Turns the Auto Water Fill function on and off. Tap and drag the button to turn on or off. Open the left door of the fridge, and then insert the water tank. Close the door and the water tank starts to be filled with water up to the a preset level some time later.  <b>NOTE</b> <ul style="list-style-type: none"> <li>• By default, Auto Water Fill is disabled. Enable this function after you have installed the water line.</li> <li>• If you open the door or push the dispenser lever, this function is stopped temporarily.</li> <li>• While the water tank fills with water, the mood light on the dispenser panel stays lit.</li> </ul>
Dispenser Lock	Turns the ice and water dispensers on and off. Tap and drag the button to turn on or off.
Door Alarm	The door alarm sounds if you leave the door open. Tap and drag the button to turn on or off.
Temp. Unit	Switch the temperature scale between Celsius and Fahrenheit. Touch °F or °C to change the scale.
Water Filter	Provides a water filter replacement tutorial and lets you reset the water filter replacement indicator. Tap to open.  <b>NOTE</b> <ul style="list-style-type: none"> <li>• After installing the water filter, tap <b>Water Filter</b>, and then tap <b>Reset</b>. Tapping <b>Reset</b> re-initializes the function that measures the time remaining until the water filter needs to be replaced again.</li> <li>• If you tap <b>Buy Filter</b>, you will be directed to the website where you can purchase a water filter.</li> </ul>
Self Check	Self Check is a self diagnoses function. Tap to open. Tap <b>START</b> to run.
Energy Saver	Turns the Energy Saver mode on and off. Tap and drag the button to turn on or off. By default, the Energy Saver mode is enabled.  <b>NOTE</b> If condensation or water drops form on or around the doors, turn the Energy Saver mode off.
Demand Response	Works with the Smart Grid energy saving manager. Tap to open. Tap and drag the button to turn on or off. See the Smart Grid section in this manual for more information.
Cooling Off	Cooling Off mode (also called Shop mode), is designed for use by retailers when they are displaying refrigerators on the shop floor. In Cooling Off mode, the refrigerator's fan motor and lights work normally, but the compressors do not run, and the refrigerator and freezer do not get cold. If Cooling Off is turned on, all cooling controls will turn to OFF on the Fridge Manager. <ul style="list-style-type: none"> <li>• To activate Cooling Off, tap <b>Activate</b> &gt; <b>Proceed</b> from <b>Cancel/Proceed</b>.</li> <li>• To deactivate Cooling Off, tap <b>Deactivate</b> &gt; <b>Proceed</b> from <b>Cancel/Proceed</b>.</li> </ul>



## Settings

Display	<ul style="list-style-type: none"> <li>You can set the screen brightness, wallpapers, auto wake-up, motion detector, theme, screen timeout, and duration of the screen saver</li> </ul>
Sound	<ul style="list-style-type: none"> <li>Set the volume and equalizer and turn on or turn off the touch sound.</li> </ul>
Wi-Fi	<ul style="list-style-type: none"> <li>Turn on or turn off a Wi-Fi connection. The current Wi-Fi network is listed first in the access point (AP) list</li> </ul>
Bluetooth	<ul style="list-style-type: none"> <li>When the Speaker mode is on, you can listen to music and media on your mobile phone or tablet through Family Hub's speaker. <ul style="list-style-type: none"> <li>Only one connected mobile phone or tablet is listed.</li> </ul> </li> <li>When the Speaker mode is off, you can search and connect to nearby Bluetooth-enabled devices. <ul style="list-style-type: none"> <li>Up to 4 recently paired Bluetooth devices are listed.</li> <li>To add a new device when 4 paired devices are listed, first unpair a paired device from the device list.</li> <li>Available devices are Bluetooth-enabled headsets, headphones, and speakers.</li> </ul> </li> </ul>
Voice	<ul style="list-style-type: none"> <li>You can check the Voice function language, turn on or turn off Voice wake-up, select Wake Word, register and manage Voice ID, and check information about Bixby.</li> </ul>
Profile	<ul style="list-style-type: none"> <li>You can add, edit, or delete a profile.</li> </ul>
Date and Time	<ul style="list-style-type: none"> <li>Make sure the Auto update function is on with a proper Wi-Fi network connection. Open the fridge door and locate the display reset button on the inner side of the door. Press the button and press again to reset the display. Then, the date and time will be synced by the time server.</li> </ul>

	<ul style="list-style-type: none"> <li>You can change the time zone through the Time zone menu.</li> </ul>
About Device	<ul style="list-style-type: none"> <li>Make sure the Software Update function is on with a proper Wi-Fi network connection.</li> <li>When updates are available, the Update button becomes active. When updates are complete, the refrigerator restarts automatically.</li> <li>Legal information displays the Open Source License Agreement. Tap the list item to open the Open Source Announcement.</li> </ul>
Easy Connection	<ul style="list-style-type: none"> <li>Easy Connection can be used with Samsung Smartphone apps, and allows you to connect your device to the same home Wi-Fi network that your smartphone is connected to.</li> </ul>
Clean Screen Mode	<ul style="list-style-type: none"> <li>Turn on so you can clean the screen without activating any apps.</li> </ul>
Accessibility	<ul style="list-style-type: none"> <li>Set to turn on or off the screen reader function for blind and lowvision users.</li> </ul>
Online Manual	<ul style="list-style-type: none"> <li>The online manual will walk you through various menus and apps that the refrigerator provides directly on the display</li> </ul>
Factory Data Reset	<ul style="list-style-type: none"> <li>Tap Reset to restart the refrigerator in Factory Data Reset mode. All user data will be removed permanently. Data that will be removed includes account information, memos, photos, and user settings. <b>CAUTION</b> Once factory reset is complete, no user data can be recovered.</li> </ul>
Remote Management	<ul style="list-style-type: none"> <li>Use Remote Management to allow a service representative to remotely diagnose problems and provide solutions.</li> <li>Remote Management requires a Wi-Fi connection.</li> </ul>

- The Remote Management menu does not appear on models that do not support Remote Management.
- To use this function, a profile must be registered or Easy Connection must be set beforehand.

### Display reset (applicable models only)

If the display is not working correctly, try resetting the display. This may resolve the problem.

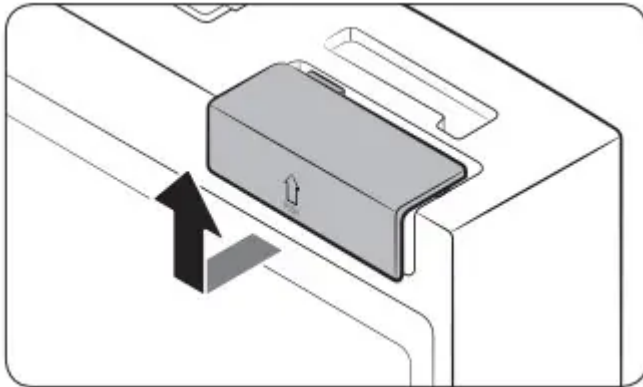

1. Open the right-side fridge door and locate the switch cover on the top right corner of the door.
2. Push up the cover to reveal the power switch.

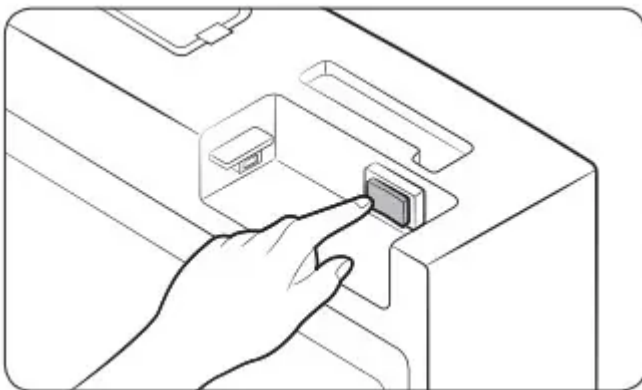

3. Turn the switch off, and then turn it on again.
4. Reinsert the switch cover to the end until you hear a clicking sound.

## SmartThings

### Installation

Visit the Google Play Store, Galaxy Apps, or Apple App Store and search for “SmartThings”. Download and install the SmartThings app provided by Samsung Electronics to your smart device.

## **NOTE**

- The SmartThings app is designed for Android 6.0 (Marshmallow) or later, iOS 10.0 or later, iPhone 6 or later, and is optimized for Samsung smartphones (Galaxy S and Galaxy Note series).
- For improved performance, the SmartThings app is subject to change without notice or discontinued support according to the manufacturer's policy.
- Recommended encryption systems include WPA/TKIP and WPA2/AES. Any newer or non-standard Wi-Fi authentication protocols are not supported.
- Wireless networks may be affected by the surrounding wireless communication environment.
- If your Internet service provider has registered the MAC address of your PC or modem for identification, your Samsung Smart Refrigerator may fail to connect to the Internet. If this happens, contact your Internet service provider for technical assistance.
- The firewall settings of your network system may prevent your Samsung Smart Refrigerator from accessing the Internet. Contact your Internet service provider for technical assistance. If this symptom continues, contact a local Samsung service center or retailer.
- To configure the wireless access point (AP) settings, see the user manual of the AP (router).
- Samsung Smart Refrigerators support both Wi-Fi 2.4 GHz with IEEE 802.11 b/g/n and Soft-AP protocols. (IEEE 802.11 n is recommended.)
- Unauthorized Wi-Fi wireless routers may fail to connect to applicable Samsung Smart Refrigerators.

## **Samsung account**

You are required to register your Samsung account to use the app. If you don't have a Samsung account, follow the app's onscreen instructions to create a free Samsung account.

## **Getting started**

Turn on the device you want to connect, open the SmartThings app on your phone, and then follow the instructions below. If a pop-up appears saying that a new device has been found, tap **ADD NOW**. If a pop-up doesn't appear, tap the + button, and then select the device you want to connect from the list of available devices. If your device isn't in the list of available devices, tap **Supported Devices**, select the device type (Refrigerator), and then select the specific device model. Follow the instructions in the app to set up your device. Once setup is complete, your refrigerator will appear as a "card" on your Devices screen.

## **Refrigerator app**

Integrated control You can monitor and control your refrigerator at home and on the go.

- Tap the refrigerator icon on the SmartThings Dashboard or tap the Devices icon at the bottom of the Dashboard, and then tap the refrigerator "card" to open the Refrigerator page.
- Check the operation status or notifications related to your refrigerator, and then change options or settings if necessary.

**NOTE** Some options or settings of the refrigerator may not be available for remote control.

Category	Item	Description
Monitoring	Fridge temperature	Displays the current temperature setting of the fridge.
	Freezer temperature	Displays the current temperature setting of the freezer.
	FlexZone™ settings	Displays the settings of the FlexZone™.
	Diagnosis	Detects abnormal operations of the refrigerator.
	Energy monitoring	Checks the accumulated power consumption of the refrigerator for the last 180 days.
Functions	Ice making	You can turn the ice making function on or off, and check the current settings of the function.
		You can also check the status and progress of ice making.
	Power Cool	You can turn Power Cool on or off, and check the current settings.
Power Freeze	You can turn Power Freeze on or off, and check the current settings.	
Alarms	Abnormally high temperature	This alarm is triggered when the fridge, the freezer, or the FlexZone™ has abnormally high temperatures.
	Door opening	This alarm is triggered if the fridge door, the freezer drawer, or the FlexZone™ drawer is open for a specific time.
	Auto Water Fill overflowing	If the Auto Water Fill function senses an overflow, it triggers this alarm to let you know the status of the overflow.
	Water filter replacement	This alarm reminds you that the water filter must be replaced.
Inside Image		You can view the inside of the refrigerator and you can know when to replace food items.
Family Hub App Link		You can connect to the App Store and download the Refrigerator app.

### SMART GRID Function (Demand Response)

When the refrigerator operates in SMART GRID (Demand Response) mode, the Energy Management Refrigerator function can control energy usage or delay the



operation of some functions to save money when energy prices or demand are the highest.

#### **NOTE**

- You can deactivate the SMART GRID (Demand Response) function at any time using the Override On/Off function.
- To use the SMART GRID (Demand Response) function, you need a separate contract with your electric utility company.

In addition, to use the Smart Grid (Demand Response) function, you must register for the service with your electric company. The company must have an EMS (Energy Management System) that supports SEP (Smart Energy profile).

#### **Using the SMART GRID (Demand Response) Function**

This feature monitors energy prices and demand information from your utility company and sends notifications to the refrigerator to run high energy consuming tasks during offpeak times when electricity costs and demand are lower. If the refrigerator receives a control signal from the utility company, the refrigerator will display the **DAL** (L3) ~ **TALR** (L4) levels on the refrigerator display and control the power consumption according to the level. Exception condition: The **DAL** and **TALR** control signals from a utility company work as long as product performance is maintained. If the refrigerator receives the SMART GRID (Demand Response) signal (**DAL** or **TALR**), the refrigerator will operate in Delay Appliance Load or Temporary Appliance Load Reduction mode.

- Delay Appliance Load (L3): The refrigerator responds to a **DAL** signal by providing a moderate load reduction for the duration of the delay period. This function controls functions that consume a lot of energy such as adjusting the Cooling system, running the defrost cycle, and making ice.
  - **DAL** mode is automatically deactivated after it lasts for the amount of time stipulated by the **DAL** signal (max. 4.5 hours) or when the Override function is turned on.
- Temporary Appliance Load Reduction (L4): The refrigerator responds to a **TALR** signal by aggressively reducing the load for a short time period. This function reduces energy consumption by stopping the compressor and controlling the functions that consume a lot of energy such as the defrost cycle and making ice.
  - **TALR** (L4) mode is automatically deactivated after it lasts for the received duration (max. 15 minutes), or when the Override function is turned on. The mode is immediately deactivated and the refrigerator returns to the normal state when the door is opened or closed, or the dispenser is used.

## To check the MAC address

1. Tap the Settings icon on the Home screen.
2. Scroll down to and open About Device.
3. The screen displays (among others) the Wi-Fi MAC address.

### Override Mode

When you want the refrigerator to ignore the SMART GRID (Demand Response) signal from the utility company, you can activate OVERRIDE mode. When you activate OVERRIDE mode, the refrigerator ignores the SMART GRID (Demand Response) signal and is not controlled by the utility company.

## Activating and deactivating Override mode

1. Tap the Fridge Manage icon.
2. On the bottom of the Fridge Manager screen, tap the Fridge Settings icon.
3. Tap Demand Response.
4. Slide the DAL/TALR override button to the ON or OFF position.

### **NOTE**

- Alternatively, you can activate or deactivate OVERRIDE mode using the SmartThings app and the Energy Management function. See the next page.

### Using the Energy Management Function

The Energy Management function enables you to control and monitor your Energy Management refrigerator using the SmartThings app for your convenience.

### **NOTE**

- To use the Energy Management refrigerator functions, you have to install the corresponding app first.

#### 1. Operational Status

- You can check the DR and Override status.

#### 2. Energy Consumption Reporting

- Shows the accumulated power consumption. Power consumption data is updated every 5 minutes.

**NOTE** The energy consumption report may differ from the power consumption specifications of the product depending on the operating environment and the quantity and type of stored food.

### 3. Delay Defrost Capability

- The Delay Defrost Capability function saves energy by delaying the defrost operation to a time specified by the user. You can configure the time, and this function will save energy during the specified period in a 24 hour cycle. If the time is not set, the function works with the default time settings. The default time settings are below:
- 6 am to 10 am: November 1st to April 30th.
- 3 pm to 7 pm: May 1st to October 31st.

#### **To change the time setting for the Delay Defrost Capability**

You can change the time setting for the Delay Defrost Capability on the app.

#### **Provision for Open Access to the Connected Product Requirements**

##### 1. SGIP Open Standards (Smart Energy Profile 2.0)

- Energy Consumption Reporting
- Demand Response

##### 2. Samsung OPEN API -

- Operational Status, User Settings & Messages
- ICE Maker Status: GET /icemaker/status/vs/0
- Door Open Alarm: GET /doors/vs/0
- DR Status: GET /drlc/vs/0
- Delay Defrost Capability
- Set Schedule of the Defrost Delay: POST /defrost/reservation/vs/0?op=add
- Get Schedule of the Defrost Delay : GET /defrost/reservation/vs/0
- Delete Schedule of the Defrost Delay: POST /defrost/reservation/vs/0?op=remove
- Defrost Delay On/OFF: POST /defrost/delay/vs/0

#### **Recommendations for voice recognition**

For the voice recognition function, there is a built-in microphone at the top of the refrigerator's display. To use the voice recognition function:

- Stand no more than 3 feet (1 meter) from the refrigerator and speak loudly and clearly towards the built-in microphone.
- Speak at a regular pace. Reduce ambient noises, such as noises from a living-room TV.

**NOTE** The voice recognition function may not work if you stand more than 3 feet (1 meter) away or if you speak too softly.

## Samsung Family Hub

### Installation

Visit the Google Play Store, Galaxy Apps, or Apple App Store and search for “Samsung Family Hub”. Download and install the Samsung Family Hub app provided by Samsung Electronics to your smart device.

### NOTE

- The Samsung Family Hub app is designed for Android 4.4 (KitKat) or higher, or iOS 8.0 or higher, and is optimized for Samsung smartphones (Galaxy S and Galaxy Note series).
- For improved performance, the Samsung Family Hub app is subject to change without notice or support may be discontinued according to the manufacturer’s policy.
- Wireless networks may be affected by the surrounding wireless communication environment.
- If your Internet service provider has registered the MAC address of your PC or modem for identification, your Samsung Smart Refrigerator may fail to connect to the Internet. If this happens, contact your Internet service provider for technical assistance.
- The firewall settings of your network system may prevent your Samsung Smart Refrigerator from accessing the Internet. Contact your Internet service provider for technical assistance. If this symptom continues, contact a local Samsung service center or retailer. Untitled-7 50 2018-08-27 4:41:06 English 51 Operations

### Samsung account

You are required to register your Samsung account to use the app. If you don’t have a Samsung account, follow the app’s onscreen instructions to create a free Samsung account.

**NOTE** To connect your smartphone and the refrigerator, register your Samsung account in Settings ->Profiles.

Item	Description
Calendar	You can share your schedule with your family.
To Do	You can create and edit a to-do list to your needs.
Memo	You can create and edit a memo to specific users.
Whiteboard	You can send White Board contents created from the refrigerator to your smartphone or vice versa.
Gallery	You can send photos from your smartphone to the refrigerator.
View Inside	You can check the inner view of the refrigerator, and use different labels to register item-specific storage periods and keep track of them for managerial purposes.
Shopping List	You can create and edit a shopping list to your needs.

### Dispenser panel

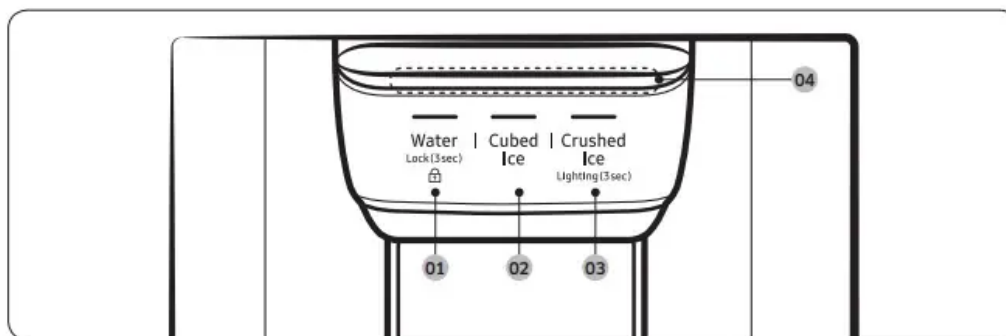

- 01 Water / Lock
- 02 Cubed Ice
- 03 Crushed Ice / Lighting
- 04 Dispenser mood light

### Water / Lock (3 sec)

Water	To dispense chilled water, press <b>Water</b> . The corresponding indicator turns on.
Lock (Dispenser panel / Dispenser lever)	To prevent use of the dispenser panel buttons and the dispenser lever, press and hold <b>Water</b> for more than 3 seconds. If you press and hold the button again for more than 3 seconds, the dispenser lock will be deactivated.

### Cubed Ice

Cubed Ice	Press <b>Cubed Ice</b> to dispense cubed ice. The corresponding indicator turns on.
-----------	---

### Crushed Ice / Lighting (3 sec)

Crushed Ice	Press <b>Crushed Ice</b> to dispense crushed ice. The corresponding indicator turns on.
Lighting	By default, the dispenser lamp turns on only when the dispenser is used. To keep the dispenser lamp turning on, press and hold <b>Crushed Ice</b> for 3 seconds. To turn the lamp off, press and hold <b>Crushed Ice</b> for 3 seconds again.

### Dispenser mood light

The Dispenser mood light lights up in the following conditions:

- When you push the dispenser lever with the dispenser lock disabled
  - Push the dispenser lever and the dispenser mood light turns on. Release the lever and the light turns off after a some time.
- While the water tank is being filled with water with the Auto Water Fill function turned on -
  - The dispenser mood light stays lit.

### Special features

## Water tank (Auto Water Fill)

The Auto Water Fill function lets you enjoy cold brewed tea in your refrigerator.

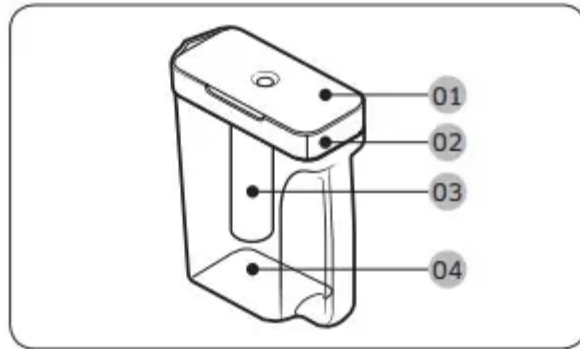

- 01 Lid
- 02 Sealed mouth
- 03 Infuser
- 04 Body

To fill the water tank

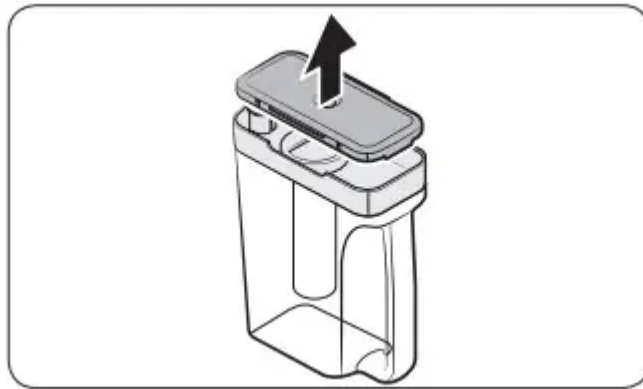

1. Grasp a handle groove of the sealed mouth, and then pull up to open the lid.
2. Put tea leaves or fruits to your taste into the infuser.

**NOTE** If you want to keep the infused water in its initial concentration, turn the Auto Water Fill function off.

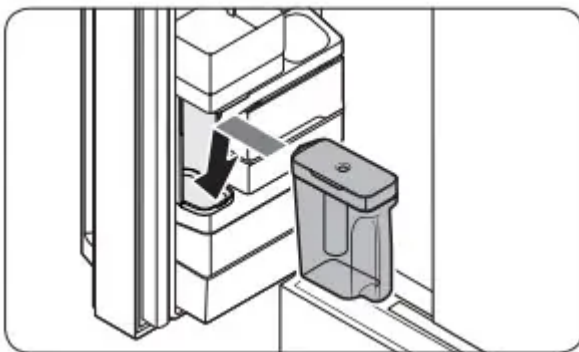

3. Enable the Auto Water Fill function on the Fridge Manager > Fridge Settings > Auto Water Fill. Open the left door of the fridge door, and then mount the water tank onto the holder. Push it straight in as shown in the illustration on the left.

4. Close the door. The infuser will start to fill with chilled water some time later.

**CAUTION** Make sure the infuser fits in the water tank holder.

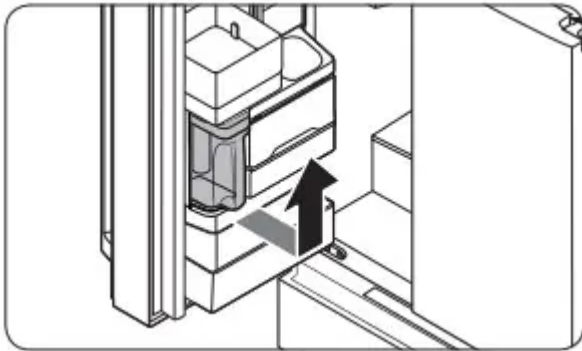

5. To drink tea, open the door and detach the water tank. Pull it straight out.

**CAUTION**

- We recommend consuming fruit infused water within 24 hours. After that, the infused water can spoil over time.
- You must clean the water tank after you have consumed up the infused water or when a long time has passed without using the water tank.

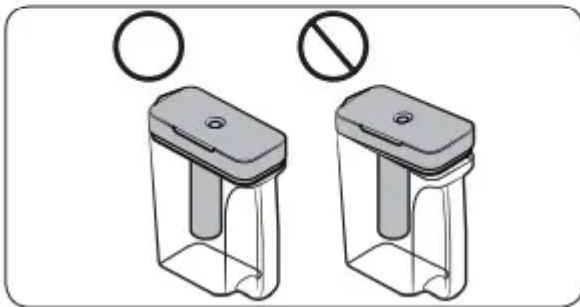
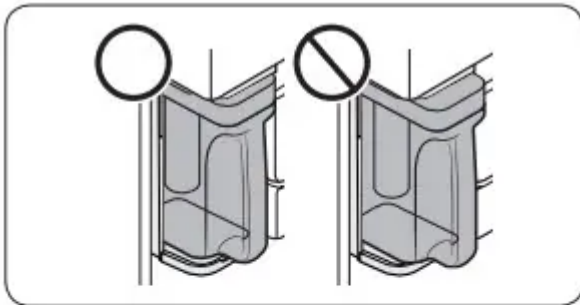

- To prevent the water tank from tipping over or leaking, make sure the water tank fits in the water tank holder.

- To prevent the water tank from spilling over or leaking, make sure the sealed mouth is properly inserted.



**NOTE**

- If the front side (specifically marked area) of the water tank has too much moisture, the water tank may not fully fill. Remove the moisture, and then try again.
- Auto Water Fill will stop supplying water for the water tank if the water tank does not fill after a certain amount of time. If this happens, check if the water line is properly connected. Remove and reinsert the water tank, and then try again.

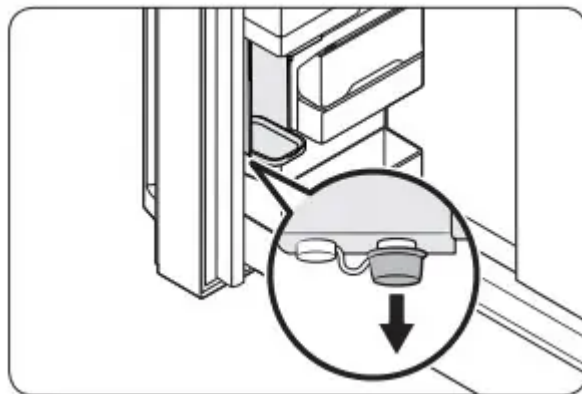

**NOTE**

- Wipe around the infuser holder if the infuser overflows or leaks.
- Water drops off if the rubber cap is opened.
- If there is a leak, a warning message appears and "Overflowing" displays on the Auto Water Fill Status. In case of a leak, open the rubber cap to drain the water. The "Overflowing" status will then change. However, if the "Overflowing" status remains, there could be a system failure. Contact your local Samsung service center.

**Water/Ice dispenser**

Using the dispenser, you can dispense water with or without ice. The water dispenser offers 3 options: chilled water, cubed ice, and crushed ice. To dispense chilled water, press **Water** on the dispenser panel. Put a water glass under the dispenser, and then push the dispenser lever.



To dispense water with ice

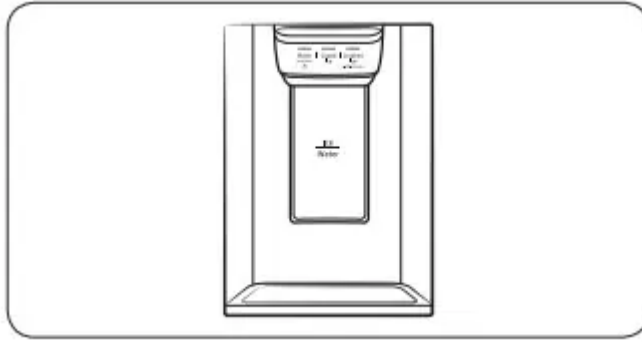

1. With the Ice Maker enabled, press Cubed Ice or Crushed Ice to select the ice type.
2. Put a water glass under the dispenser, and then push the dispenser lever with the glass. Ice will be dispensed from the dispenser.
3. Press Water to select water.
4. Push the dispenser lever with the glass. Water will be dispensed from the dispenser.

#### **NOTE**

- The dispenser will stop dispensing if you keep pushing the dispenser lever for about 1 minute. To dispense more water, release and push the lever again.
- Make sure the glass is in line with the dispenser to prevent the dispensed water from spilling out.
- If you do not use the water dispenser for 2-3 days, the dispensed water may have an abnormal smell or taste. This is not a system failure. Discard the first 1-2 glasses of water.

#### **Ice maker**

The refrigerator has a built-in ice maker that automatically dispenses ice so that you can enjoy filtered water with cubed or crushed ice. Ice making After you have installed your refrigerator and plugged it in, follow these instructions to ensure proper ice making and to keep the ice bucket full of ice:

1. Let the refrigerator operate for at least 24 hours to ensure optimal performance.
2. Dispense the first 4 to 6 ice cubes into a glass.
3. Wait another 8 hours and dispense another 4 to 6 ice cubes.
4. Then, wait another 16 hours and dispense the first glass-full of ice.

#### **NOTE**

- If you consume all the ice at once, you must wait 8 hours before dispensing the first 4 to 6 cubes. This ensures that the ice bucket is filled with ice properly.
- Ice cubes generated rapidly may look white, which is normal.

## Diagnosis

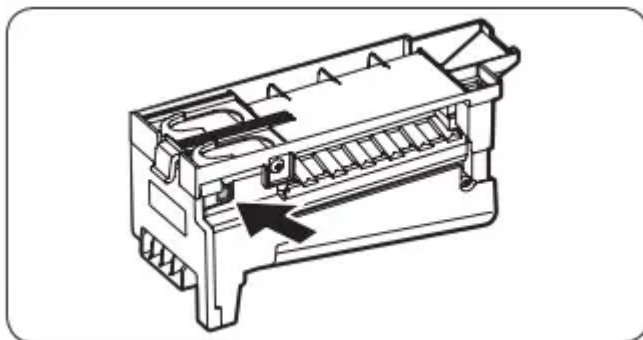

If ice does not dispense, first check the ice maker.

1. Press Test on the side of the ice maker. You will hear a chime (ding-dong) when you press the button.
2. You will hear another chime if the ice maker is operating properly.

### **CAUTION**

- If the ice making chime rings repeatedly, contact your waterline installer or a local Samsung service center.
- Do not press Test repeatedly after the ice tray is filled with ice or water. Water may overflow or ice may jam.
- Do not put food in the ice bucket. The frozen food may damage the ice maker, especially when you open or close the door.
- When the refrigerator recovers power after a power failure, the ice bucket may contain a mix of melted and jammed ice cubes, which can prevent the ice maker from working properly. To prevent this, make sure to empty the ice bucket so the ice bucket can refill with fresh, loose ice cubes.
- Do not put fingers or any objects into the dispenser outlet or the ice maker. This can cause physical injury or property damage.
- When reinserting the ice maker tray, make sure that the tray is properly centered at the entrance. Otherwise, the tray can get stuck.

### **If You Turn the Ice Maker Off**

To turn the ice maker off, tap Fridge Manager > Fridge Settings > Ice Maker on the Home screen, and then select Off. Make sure to empty the ice bucket. Remaining ice cubes may clump together, making it difficult to remove them.

To remove the ice bucket, see the Ice bucket section.

### **NOTE:**

Removal of the ice bucket does not affect the thermal and mechanical performance of the refrigerator.

## Water clouding

Water supplied to the refrigerator flows through a core alkaline filter. During this filtering process, the water pressure of the water increases and the water becomes saturated with oxygen and nitrogen. This causes the water to look misty or cloudy temporarily when dispensed. This is normal and the water will look clear after a few seconds.

## FlexZone™ divider

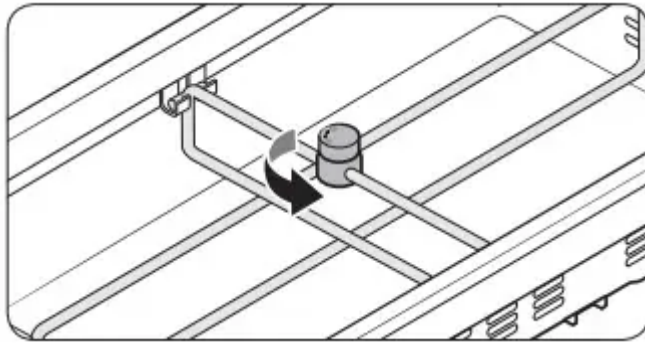

You can change the divider position. To do this, unlock the divider by turning the divider dial counter clockwise. Then, move the width and height bars as appropriate. When done, turn the dial clockwise to lock the divider.

**NOTE** If the divider lock does not function, wipe the bars to remove moisture on them.

# Maintenance

## Handling and care

### Ice bucket

If you do not dispense ice for an extended period, ice may form clumps inside the bucket. If this happens, remove and empty the ice bucket.

1. While grabbing the handle of the ice bucket, slightly lift up the bucket, and then remove it to the front.

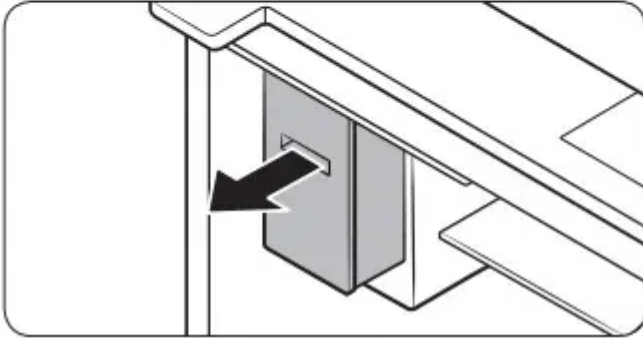
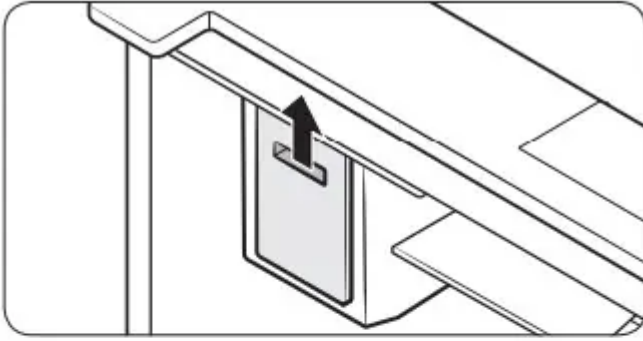

2. Remove the remaining ice cubes and put the ice bucket back into place.

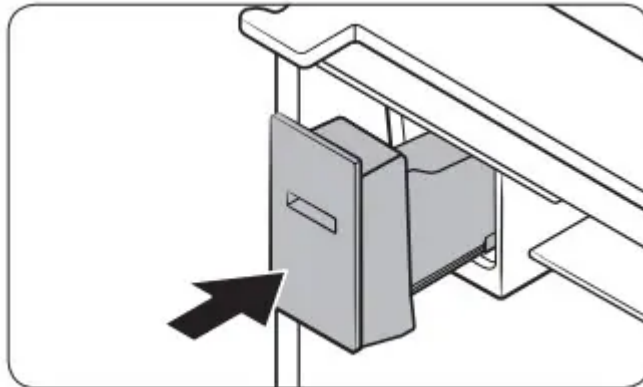

If the ice bucket is not firmly inserted, turn the ice screw 90 degrees, and then try again.

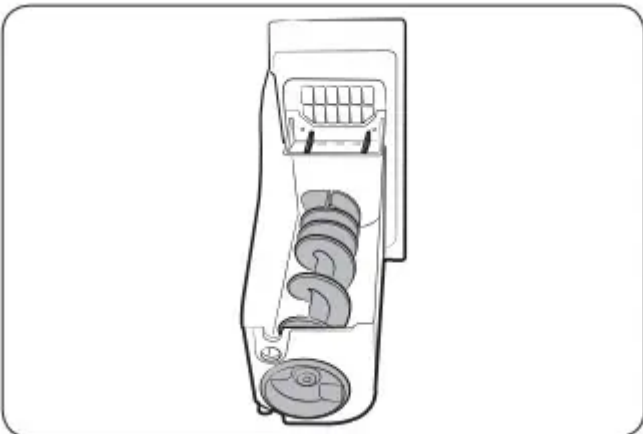

## **CAUTION**

- Do not apply excessive force to the bucket cover. The cover may break.
- Do not forcefully close the door. Water may spill over the ice maker.
- To prevent injury, make sure to clean up any ice or water that has spilled on the floor.
- To prevent accidents or injury, do not let children play with the water dispenser or the ice maker.
- Do not put your hand or an object into the ice chute. This may cause physical injury or product damage.
- Use only the provided ice bucket. Third-party ice buckets may cause a system failure.
- Use only potable water that is connected to the water supply line.

## **NOTE**

- The water pressure required for ice making is between 20 psi and 125 psi.
- Noise from the ice maker as it produces ice during the ice making process is normal.
- While the door is open, neither the ice maker nor the water dispenser operates

### **Auto Water Fill**

1. Grasp a handle groove of the sealed mouth, and then pull up to remove.

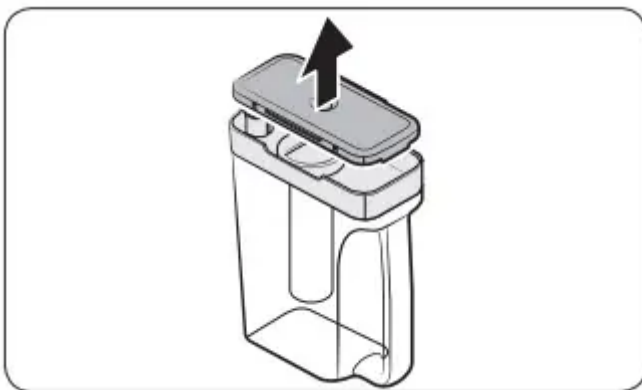

2. Grasp both sides of the sealed mouth, and then lift to remove.

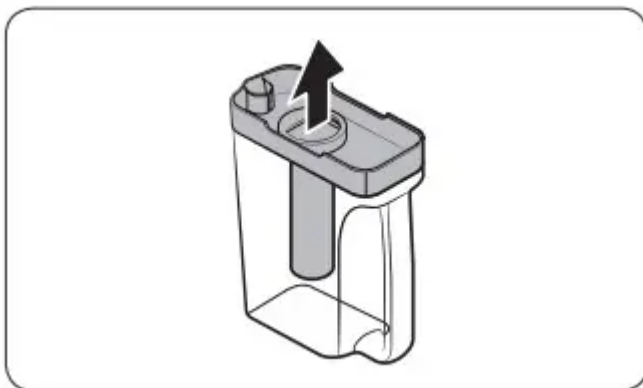

3. While slightly twisting the infuser, pull it out of the sealed mouth.

4. Clean the infuser with regular dishwashing liquid and running water. Rinse and dry well.
5. Reassemble the Auto Water Fill in the reverse order of disassembly.

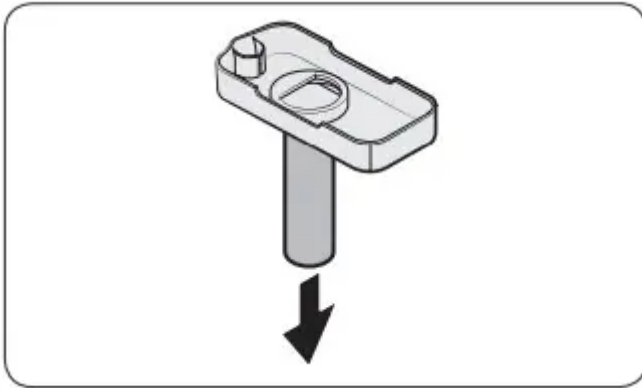

**CAUTION** Water pitcher and lid are not dishwasher safe and can deform under high temperatures. Please hand wash as needed.

### Fridge shelves

The appearance of the shelves differs by model.

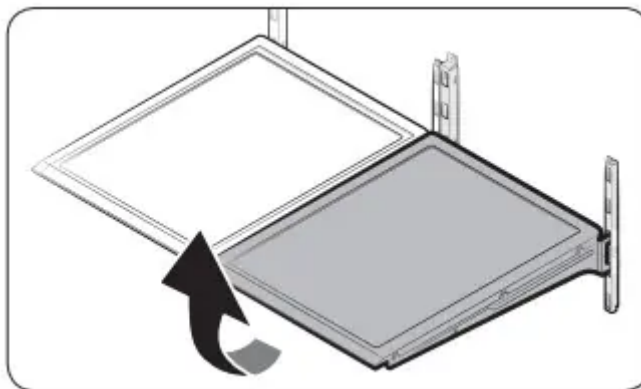

- To remove a shelf, fully open the corresponding door. Hold the front of the shelf, and then gently lift up and slide out

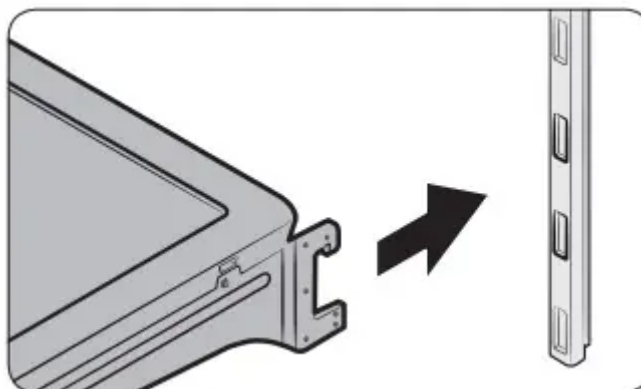

**NOTE** Do not lift up the shelf fully when removing or reinserting the shelf. The rear wall of the fridge room can be dented.

- To reinsert, hold the shelf at an angle so the front is higher than the back, and then insert the top hook into the top shelf notch. Then, lower the shelf and insert the bottom shelf hook into the bottom shelf notch.

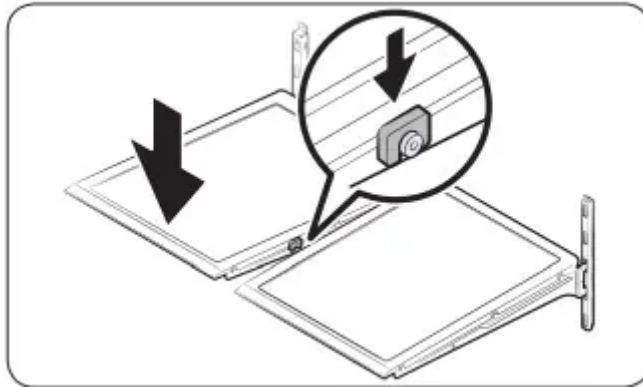

**CAUTION**

- The tempered glass shelves are heavy. Use caution when removing them.
- The shelf must be inserted correctly. Do not insert upside down.
- Glass containers may scratch the surface of glass shelves.

**Foldable shelf**

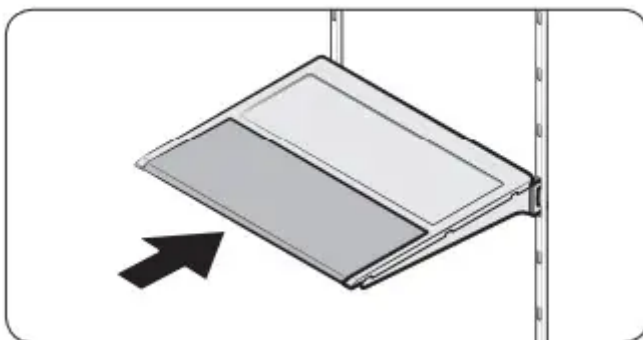

To remove, slide up the front of the shelf so that it folds. Then gently lift up and pull out. To reinsert, place the shelf on the angled frame in the main unit, and then, press down to unfold.



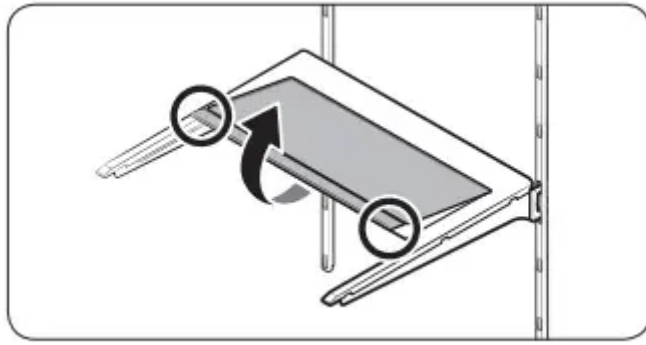

**CAUTION** After sliding the foldable shelf in and folding it, the front of the shelf can be removed for your convenience. If you use the shelf without removing the front of the shelf, be aware that it can separate from the rear portion, be careful of its possible separation.

### Recommended foldable shelf location

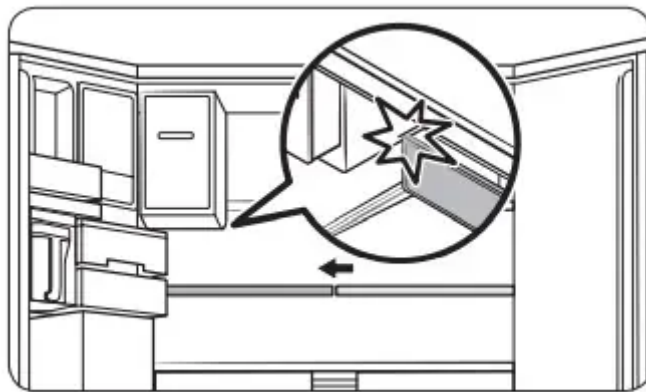

The foldable shelf folds up from the center, giving you more room for storage.

- Insert the shelf in the right side of the fridge. Left side insertion does not allow the shelf to fold completely.
- To fold, push the front area of the shelf inward so that it folds up from the middle.

**CAUTION** Do not lift up quickly or twist the foldable shelf to take out food under it. It may fall off.

## Vegetable shelf

1. Slide out the left-side vegetable drawer.

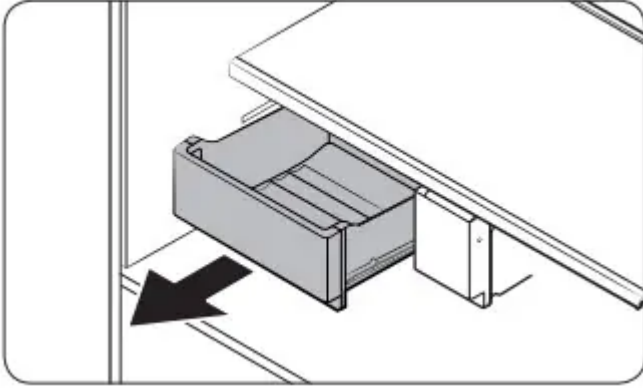

2. Fully open the door, and then remove the shelf.

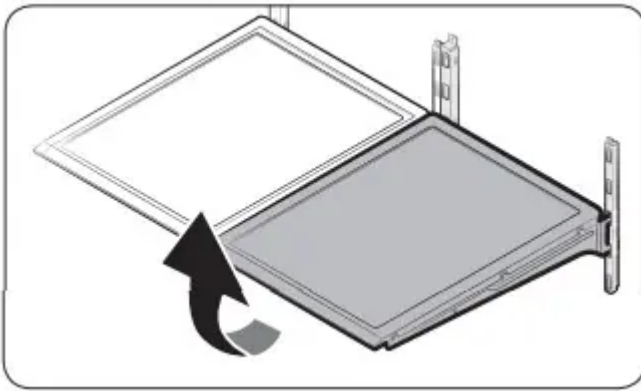

3. While supporting the vegetable shelf with one hand, slide it out with the other hand.

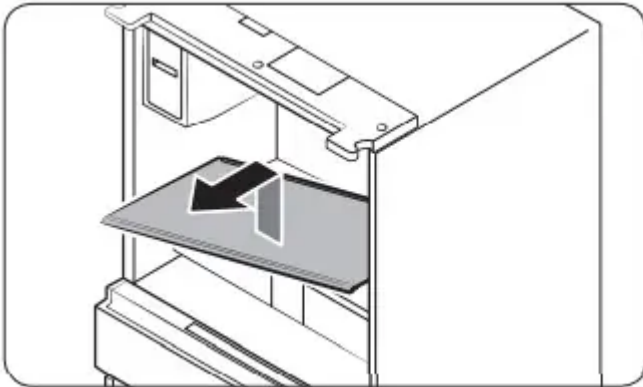

**NOTE** To use the space that is opened up after removing the foldable shelf, take out the vegetable shelf. To reinsert, follow the steps above in the reverse order.

## Door bins

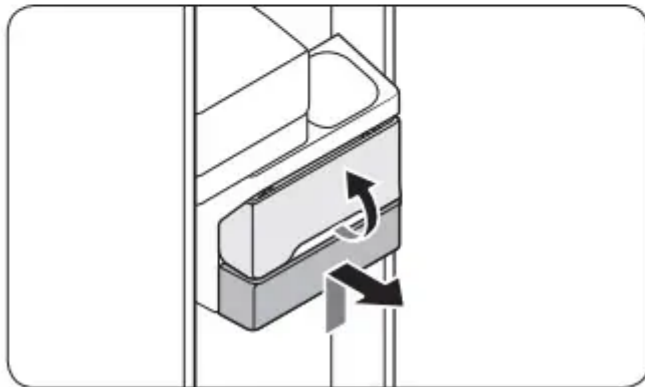
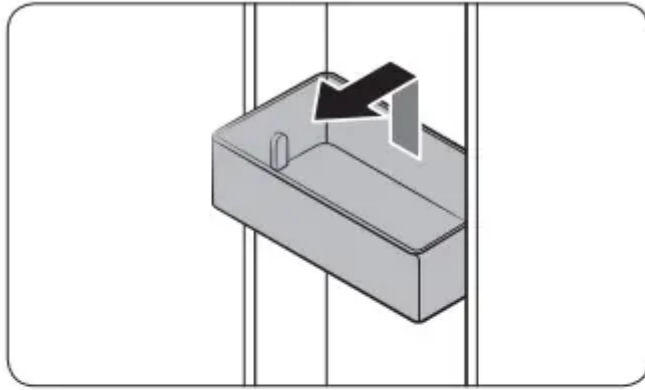

- To remove the top door bin, hold the front sides of the bin, and then gently lift up to remove.
- To reinsert, insert the door bin slightly above its final location making sure that the back of the bin is against the door. Hold the rear of the door bin with both hands, and then press down so that it fits snugly.

### **CAUTION**

- Do not remove a bin that is filled with food. Empty the bin beforehand.
- Use caution when opening the door if the bottom bin contains larger bottles, which may fall over.
- Do not allow children to play with the bins. Sharp corners of the bin may cause injury.

## **Fridge drawers**

### **Vegetable / fruit drawers**

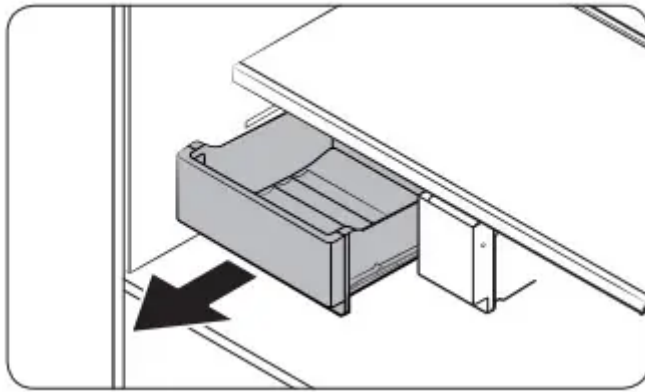

Gently lift up the front of the drawer and slide out.

- We recommend that you remove the door bins before removing the drawer. This is to prevent damage to the door bins.
- To reinsert, insert the drawer into the frame rails and then slide inward.

#### **FlexZone™ basket**

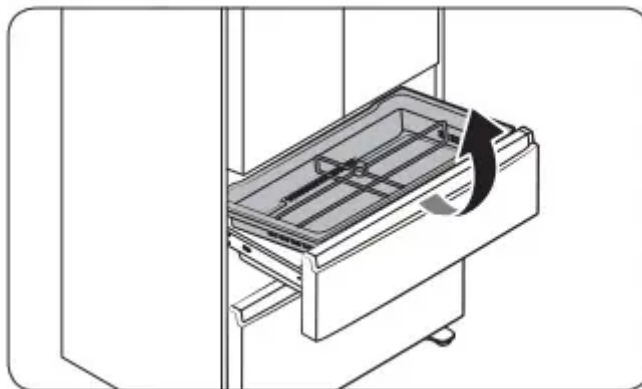

- To remove, fully open the FlexZone™ drawer. Lift up the FlexZone™ basket, and then pull out with both hands.
- To reinsert, fully open the FlexZone™ drawer. While tilting up the front of the basket, insert the rear of the basket into the rail assembly. Lower the front until the basket settles down. If the divider lock does not function, wipe the bars to remove moisture on them.

**To remove the divider and the metal cooling plate (applicable models only) from the FlexZone™ basket**

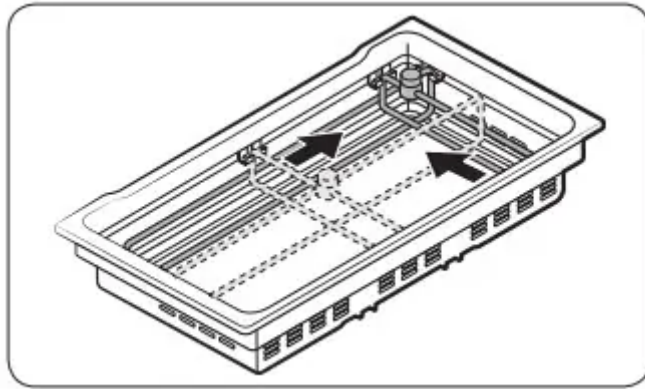

1. Unlock the divider by turning the divider dial counter clockwise.
2. Slide the divider to the end as shown.

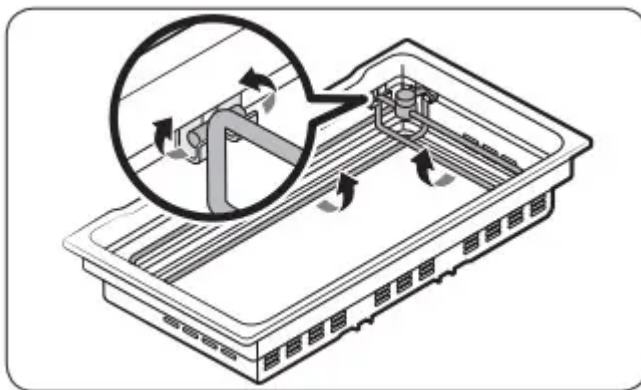

3. Unlock the divider by turning the divider dial counter clockwise. 2. Slide the divider to the end as shown.

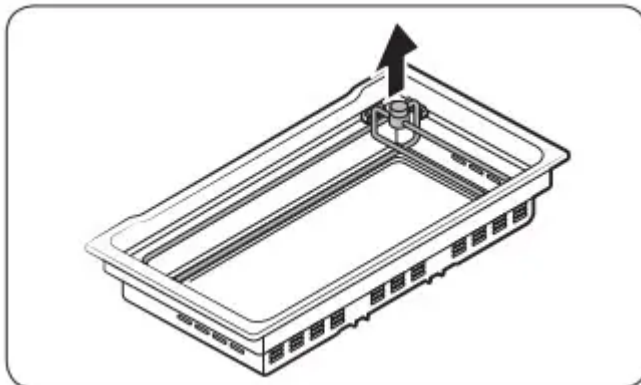

4. Hold the divider and pull up to remove.

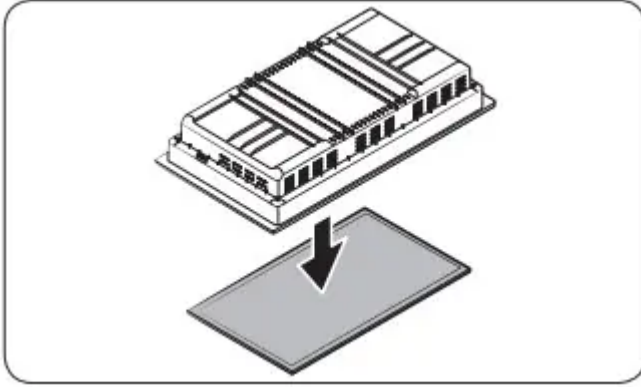

5. Turn over the basket to remove the metal cooling plate.

**CAUTION** The basket and the metal cooling plate are heavy. Use caution when handling them. Careless handling may cause personal injury or property damage.

#### **To reinsert the metal cooling plate**

Reinsertion in the reverse order of removal. Reinsert the divider into the FlexZone™ basket firmly until you hear a clicking sound.

### **Freezer baskets**

#### **Upper basket**

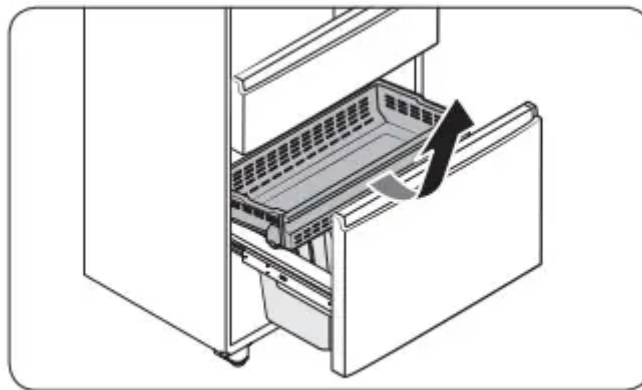

- To remove, fully slide open the freezer drawer. Push the upper basket to the end, and then pull up to remove.
- To reinsert, align the front wheels of the upper basket with the end of the lower basket. Slide the upper basket to the front.

#### **Lower basket**

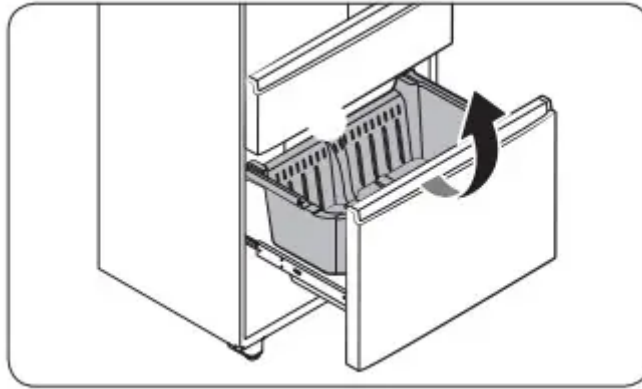

- To remove, first remove the upper basket. Then, tilt up the front of the lower basket to pull out.
- To reinsert, put the basket into the rail assembly with the rear side first.

### **CAUTION**

- Do not twist the basket when removing or reinserting the basket. The basket can be scratched.
- To prevent physical injury, property damage, or suffocation, keep children away from freezer baskets that have been removed.
- Do not remove the divider.
- Put the wheels of the upper basket on the end of the rails of the lower basket. Then, slide the upper basket all the way to the front. Otherwise, the drawer does not open or close properly, which causes frost to build up.

## **Cleaning**

### **Interior and exterior**

### **WARNING**

- Do not use benzene, thinner, home/car detergent, or Clorox™ to clean the refrigerator. They may damage the surface of the refrigerator and cause a fire.
- Do not spray water onto the refrigerator. This may cause electric shock.

Regularly use a dry cloth to remove all foreign substances such as dust or water from the power plug terminals and contact points.

1. Unplug the power cord.
2. Use a moistened, soft, lint-free cloth or paper towel to clean the refrigerator's interior and exterior.
3. When done, use a dry cloth or paper towel to dry well.
4. Plug in the power cord.

### Ice / Water dispenser

**CAUTION** When crushed ice is selected, some residual ice chips may collect in the ice chute. To prevent this, remove the residual ice from the chute using a soft, clean cloth.

### Rubber seals

If the rubber seals of a door become dirty, the door may not close properly and reducing refrigerator performance and efficiency. Use a mild detergent and damp cloth to clean the rubber seals. Then, dry well with a cloth.

### Inner-view camera

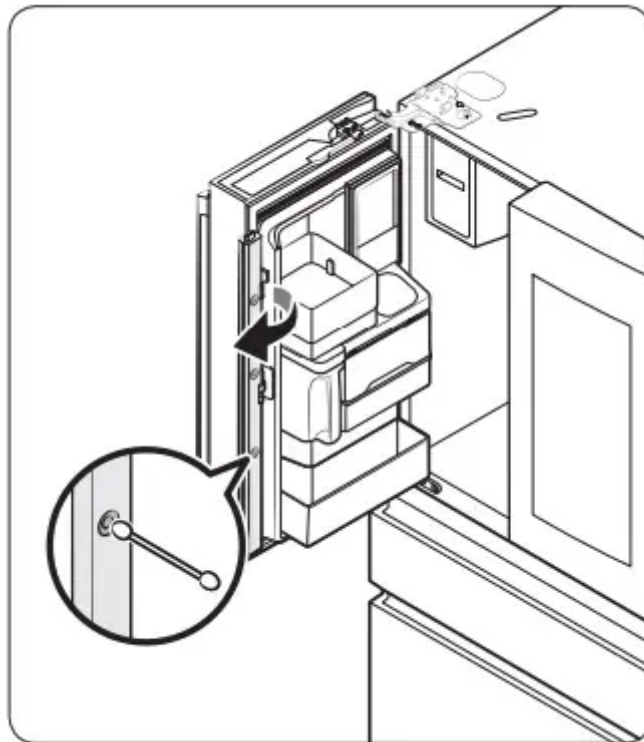

**NOTE** Use a cotton swab or microfiber cloth to clean the camera on the left-side door of the fridge.

### Rear panel

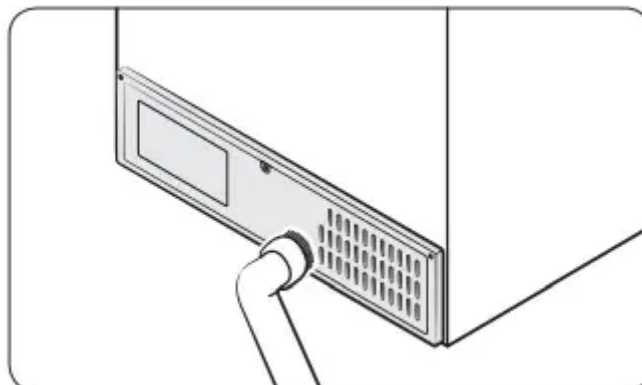

To keep cords and exposed parts of the rear panel free of dirt, vacuum the panel once or twice a year. CAUTION Do not remove the rear panel cover. Electric shock may occur.

## Replacement

### Water filter

#### **WARNING**

- Do not use third-party water filters. Use only Samsung-provided or -approved filters.
- Unapproved filters may leak and damage the refrigerator, causing electric shock. Samsung is not responsible for any damage that may occur from use of third-party water filters. The Filter Reset indicator (  ) turns red to let you know it is time to replace the water filter. Before replacing the filter, make sure the water supply line is shut off.

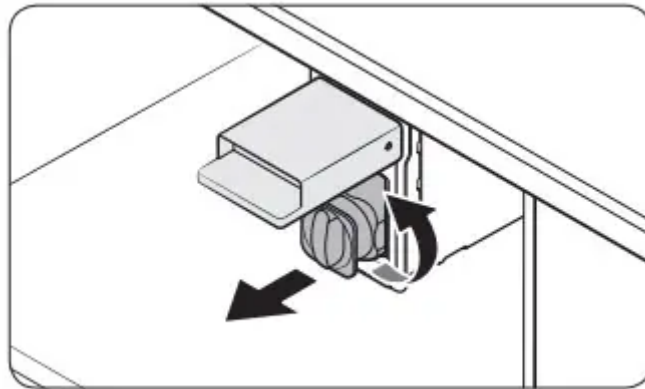

1. While opening the filter cover, turn the knob of the filter cartridge counter clockwise by 90 degrees (1/4 turn). The filter cartridge unlocks.
2. Pull out to remove the cartridge.
  - If the water filter is severely contaminated, the cartridge may not be easily removable. In that case, use force to pull it out.
  - To prevent water leaks from the opening, pull the cartridge straight out while removing it.

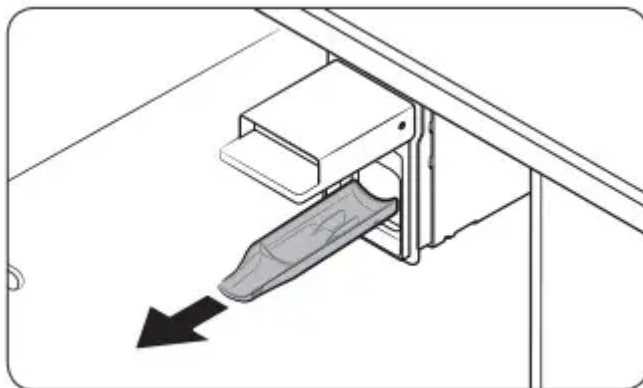

**NOTE** To prevent overflow, empty and dry the water filter tray

3. Insert a new filter cartridge. Use only Samsung-provided or approved filters.

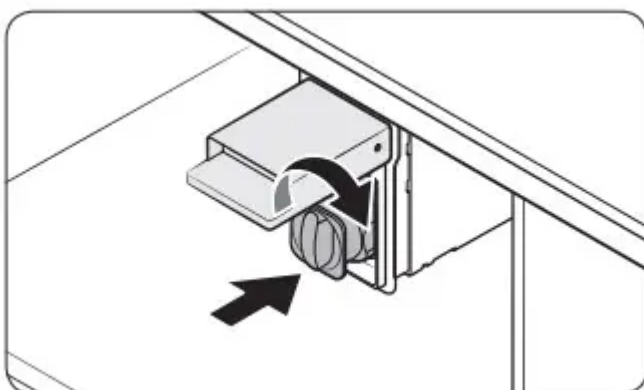

4. Turn the cartridge knob clockwise to lock into place.

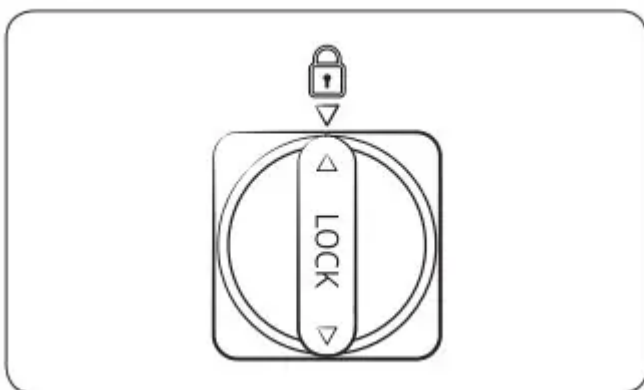

5. On the Home screen, tap Fridge Manager > Fridge Settings > Water Filter, and then select RESET. The filter indicator turns off.

6. When you are done replacing the filter, open the water valve and run water through the dispenser for about 7 minutes. This is to remove impurities and air from the water line.

**NOTE:**

- A newly installed filter may cause the water dispenser to spurt water briefly. This is because air has entered the waterline.

- The replacement process may cause the water dispenser to drip for a short period of time. If it drips, simply wipe up any water on the floor with a dry towel.

### **Reverse osmosis water filtration system**

The water pressure of the water supply system to a reverse osmosis water filtration system must be between 35 psi and 120 psi (241 kPa and 827 kPa). The water pressure of the reverse osmosis water filtration system to the refrigerator's cold water line must be at least 40 psi (276 kPa). If the water pressure is below these specifications:

- Check if the sediment filter in the reverse osmosis system is blocked. Replace the filter if necessary.
- Refill the water tank in the reverse osmosis system with water.
- If your refrigerator has a water filter, it may further reduce the water pressure when used in conjunction with a reverse osmosis system. Remove the water filter.

For more information or servicing, contact a licensed plumbing professional.

### **Ordering a new filter**

To purchase a new water filter, contact a local Samsung service center.

### **LED Lamps**

To replace the lamps of the refrigerator, contact a local Samsung service center.

### **WARNING**

- The lamps are not user-serviceable. Do not attempt to replace a lamp yourself. This can cause electric shock.

## **Troubleshooting**

Before calling for service, review the checkpoints below. Any service calls regarding normal situations (No Defect Cases) will be charged to users.

### **General**

#### **Temperature**

- Fridge/freezer does not operate. Fridge/freezer temperature is warm.
  - Power cord is not plugged in properly.
    - Properly plug in the power cord.
  - Temperature control is not set correctly.
    - Set the temperature lower.

- Refrigerator is located near a heat source or direct sunlight.
  - Keep the refrigerator away from direct sunlight or a heat source.
- Not enough clearance between refrigerator and nearby walls or cabinets.
  - Make sure there is a gap of at least 2.5 inches (5 cm) between the refrigerator back and sides and any nearby walls or cabinets.
- Energy Saver mode is activated.
  - Deactivate Energy Saver mode.
- The refrigerator is overloaded. Food is blocking the refrigerator vents.
  - Do not overload the refrigerator. Do not allow food to block vents
- Fridge/freezer is over-cooling.
  - Temperature control is not set correctly.
    - Set the temperature higher.
- Interior wall is hot.
  - Refrigerator has heat-proof piping in the interior wall.
    - To prevent condensation from forming, the refrigerator has heat-proof piping in the front corners. If the ambient temperature rises, this equipment may not work effectively. This is not a system failure.

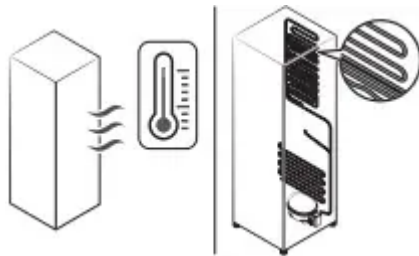

### **Odors**

- Refrigerator has odors.
  - Spoiled food.
    - Clean the refrigerator and remove any spoiled food.
  - Food with strong odors.
    - Make sure strong smelling food is wrapped airtight.

### **Frost**

- Frost around the vents.
  - Food is blocking the vents.
    - Make sure no food blocks the refrigerator vents.

- Frost on interior walls.
  - Door is not closed properly.
    - Make sure food does not block the door. Clean the door gasket.
- Fruits or vegetables are frozen.
  - Fruits or vegetables are stored in the FlexZone.
    - Do not store most kinds of fruit or vegetables in the FlexZone.

### **Condensation**

- Condensation forms on the interior walls.
  - If door is left open, moisture enters the refrigerator.
    - Remove the moisture and do not leave a door open for extended periods of time.
  - Food with high moisture content.
    - Make sure food is wrapped airtight.

### **Water/ice (dispenser models only)**

- Water flow is weaker than normal.
  - Water pressure is too low.
    - Make sure the water pressure is between 20 to 120 psi.
- Ice maker makes a buzzing sound.
  - The ice maker function is activated, but the water supply to the refrigerator has not been connected.
    - Activate the Ice Maker off.
- Ice maker does not make ice.
  - Ice maker has just been installed.
    - You must wait for 12 hours for the refrigerator to make ice.
  - Freezer temperature is too high.
    - Set the freezer temperature below 0 °F (-18 °C) or -4 °F (-20 °C) in warm ambient air.
  - Dispenser Lock is activated.
    - Deactivate dispenser Lock.
  - Ice maker is off.
    - Turn on the ice maker.



- Ice does not dispense.
  - Ice may jam if the ice dispenser is not used for a long time (approx. 3 weeks).
    - If you won't be using the refrigerator for a long time, empty the ice bucket and turn off the ice maker.
  - Ice bucket is not properly inserted.
    - Make sure the ice bucket is properly inserted.
  - Water line is not connected properly or water supply is not on.
    - Check if the water line is installed correctly. Check if the water line stop cock is closed.

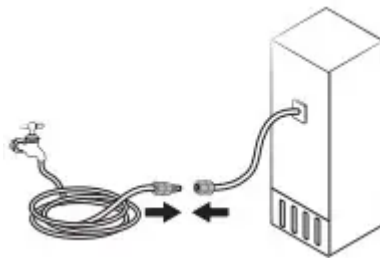

- Water does not dispense.
  - Water line is not connected properly or water supply is not on.
    - Check if the water line is installed correctly. Check if the water line stop cock is closed.

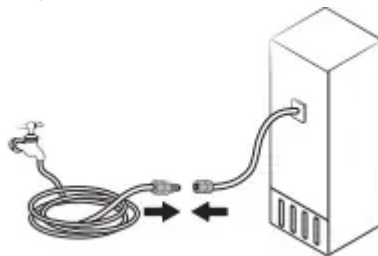

- Dispenser Lock is activated.
  - Deactivate dispenser Lock.
- A third-party water filter was installed.
  - Use only Samsung-provided or approved filters.
  - Unapproved filters may leak and damage the refrigerator.
- Water filter indicator turns on or blinks.
  - Replace the water filter. After replacing, reset the filter indicator sensor.

## Do you hear abnormal sounds from the refrigerator?

Before calling for service, review the checkpoints below. Any service calls related to normal sounds will

### These sounds are normal.

- When starting or ending an operation, the refrigerator may make sounds similar to a car engine ignition. As the operation stabilizes, the sounds will decrease. be charged to the user.

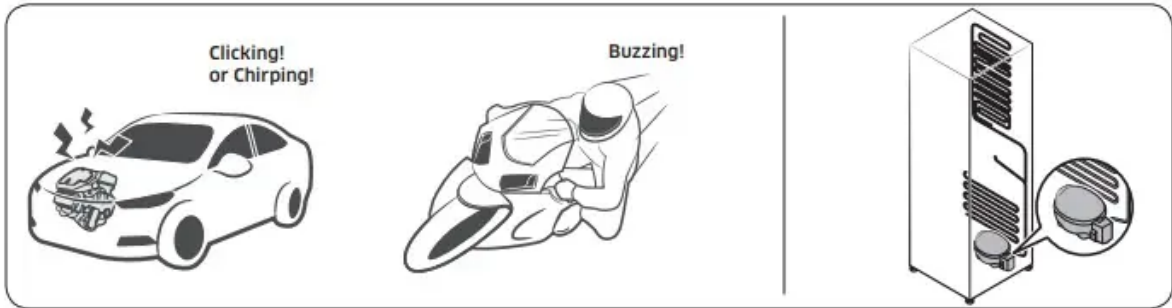

- While the fan is operating, these sounds may occur. When the refrigerator reaches the set temperature, the fan sound will stop.

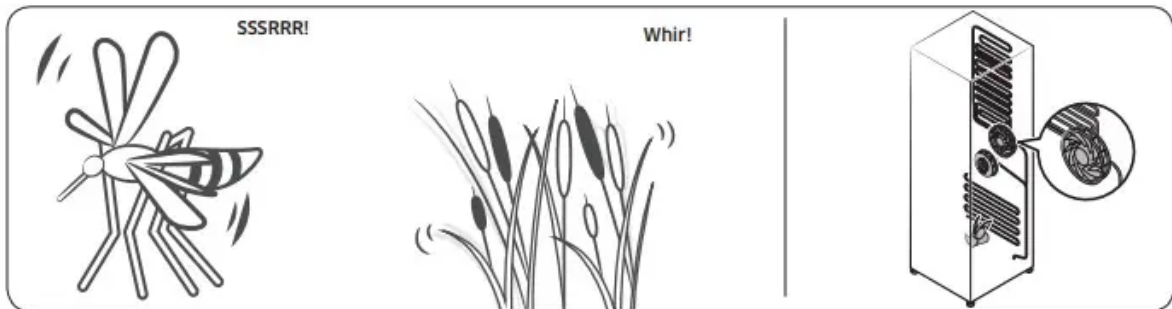

- During a defrost cycle, water may drip on the defrost heater, causing sizzling sounds

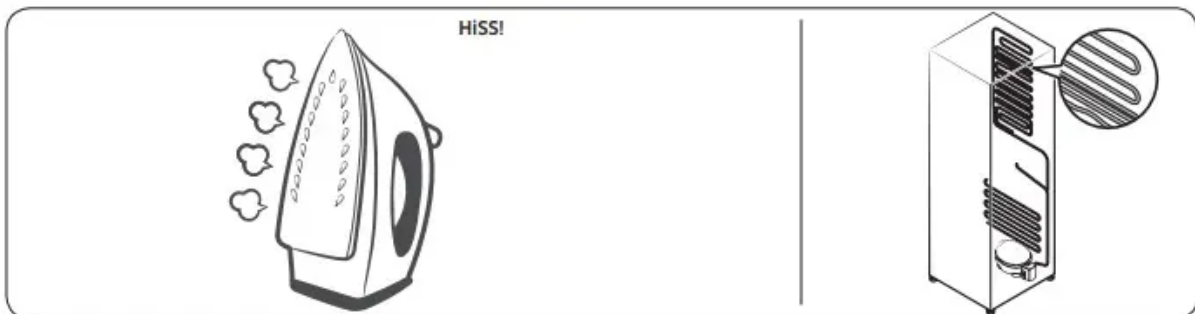

- As the refrigerator cools or freezes, refrigerant gas moves through sealed pipes, causing bubbling sounds.

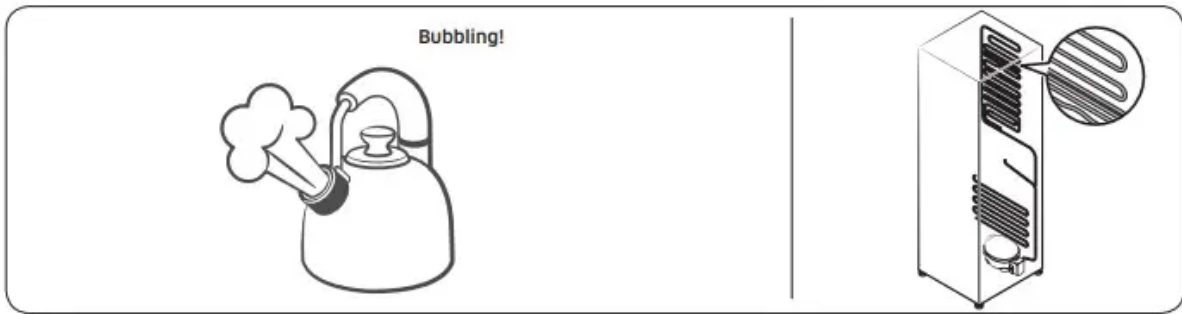

- As the refrigerator temperature increases or decreases, plastic parts contract and expand, creating knocking noises. These noises occur during the defrosting cycle or when electronic parts are working.

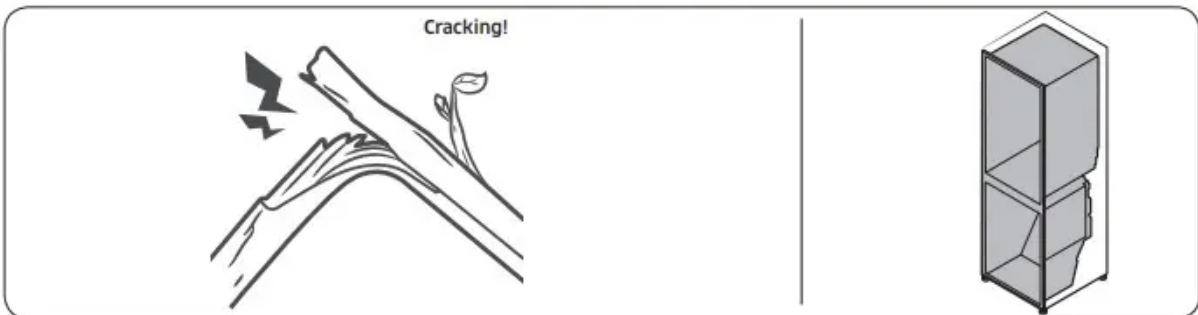

- For ice maker models: When the water valve opens to fill the ice maker, buzzing sounds may occur.
- Due to pressure equalizing when you open and close the refrigerator door, whooshing sounds may occur.

## SmartThings

- Could not find “SmartThings” in the app market.
  - The SmartThings app is designed for Android 6.0 (Marshmallow) or later, iOS 10.0 or later, iPhone 6 or later, and is optimized for Samsung smartphones (Galaxy S and Galaxy Note series).
- The SmartThings app fails to operate.
  - The SmartThings app is available for applicable models only.
  - The old Samsung Smart Refrigerator app cannot connect with Samsung Smart Home models.
- The SmartThings app is installed but is not connected to my refrigerator.
  - You must log into your Samsung account to use the app.
  - Make sure that your router is operating normally.

- If you have not connected your refrigerator to the SmartThings App after the app was installed, you must make the connection using the device registration function of the app.
- Could not log into the app.
  - You must log into your Samsung account to use the app.
  - If you don't have a Samsung account, follow the app's onscreen instructions to create one.
- An error message appears when I try to register my refrigerator.
  - Easy Connection may fail due to the distance from your access point (AP) or electrical interference from the surrounding environment. Wait a moment and try again.
- The SmartThings app is successfully connected to my refrigerator but does not run.
  - Exit and restart the SmartThings app or disconnect and reconnect the router.
  - Unplug the power cord of the refrigerator, and then plug it in again after 1 minute.

### **Samsung Family Hub**

- Could not find "Samsung Family Hub" in the app market.
  - The Samsung Family Hub app is available for smartphones that run Android 4.4 (KitKat) or higher, or iOS 8.0 or higher.
- Could not log into the app.
  - You must log into your Samsung account to use the app.
  - If you don't have a Samsung account, follow the app's onscreen instructions to create one.

### **Smart Grid**

- What Do I Need to use the Energy Management and Smart Grid functions?  
To use the Smart Grid (Demand Response) and Energy Management functions on your refrigerator, you need the following:
  - Devices
    - A wireless access point (router)
    - A Samsung Energy Management-supported refrigerator
    - A smartphone



- Registration
  - Connect your refrigerator to your home Wi-Fi network.
  - Register for the EMS service with your electric company. Your electric company must have an EMS (Energy Management System) supporting SEP (Smart Energy profile).
- App
  - Download the SmartThings app from the Google Play Store, Apple App Store, or Samsung Galaxy Apps.
  - Install and run the SmartThings app on your smartphone.
- Why isn't the Energy Management function working normally?
  - Make sure that your home router is operating normally with proper Internet service and connection.
  - Make sure that the refrigerator is connected to the AP (router).
  - Checkpoints
    - Connect your smartphone to the router (AP, Access Point), and then check if you can browse the Internet on the smartphone.
- Why isn't the Delay Defrost Capability working normally?
  - Make sure that your home router is operating normally with proper Internet service and connection.

## LCD

- Cannot connect to my TV.
  - This refrigerator can connect only with Samsung Smart TV 6400 series or higher models released since 2015. Please check the model name of your TV first.
  - Network connections may suffer temporary interruptions. Turn your TV off, and then try again.
- The inner view picture looks bulged out or incomplete.
  - The edges of the inner view may look bulged out. The bulging is caused by the convex lens of the camera.
  - The inner view may be incomplete due to the blind spots on the left and right corners or screened depending on the layout of food items. Make sure to place food items in the front center.
- The displayed measurement on the Fridge Manager is not correct.
- The displayed conditions may differ from the actual temperature and humidity

**Warning**

This content is compiled from multiple sources and is provided for reference purposes only. It may not be complete or fully applicable to all situations. If you are unable to resolve your issue, please contact the product manufacturer or an authorized service provider for official support.

---

Document generated by [ManualsFile](#)