

USING THE RANGE

In Case of a Power Failure

- In the event of a power failure, the oven is inoperable and no attempt should be made to operate it. However, the surface burner may be lit with a match. Using extreme caution, hold a lit match near the ports beneath the surface burner cap, then slowly turn the knob to the LITE position. Once lit, surface burners will continue to operate normally.

Surface Burners

Lighting a Surface Burner

WARNING: Burners should be operated only when covered by cookware. Burner flames not covered by cookware present a risk of fire or clothing ignition. Never let flames extend beyond the sides of the cookware. Failure to comply may result in serious injury.

- Make sure all burners are in their correct locations and fully assembled before attempting to operate any burner.
- Select a burner and find its control knob. Push the knob in and turn it to the LITE position
- You will hear a clicking noise the sound of the electric spark igniting the burner. When one burner is turned to LITE, all burners will spark. Sparking will continue as long as the knob remains at LITE. Once gas is ignited, turn the knob to adjust the flame size.

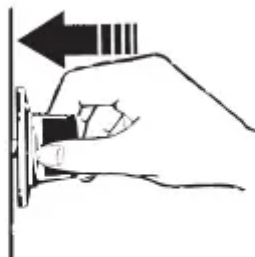

Push the control knob in and turn it to the LITE position.

Selecting a Flame Size

- Watch the flame, not the knob, as you adjust heat. When rapid heating is desired, the flame size should match the size of the cookware you are using. Flames larger than the bottom of the cookware will not heat faster and may be hazardous.

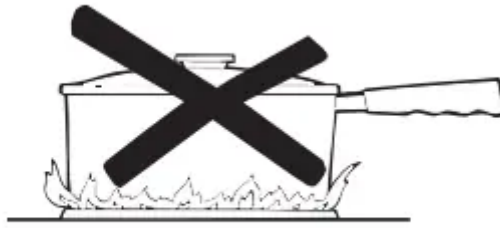

These flames are too large for the pot

Using the Surface Burners

NOTES:

- Do not operate the burner for an extended period of time without cookware on the grate. The finish on the grate may discolor or chip without cookware to absorb the heat.
- Do not attempt to disassemble any burner while another burner is on. Damage to the product may occur.
- Be sure the burners and grates are cool before you place your hand, a pot holder or cleaning materials on them.
- Your rangetop offers convenience, cleanability and flexibility for a wide range of cooking applications.
- The smallest burner is the simmer burner. A simmer burner turned down to LO provides precise cooking performance for foods such as delicate sauces that require low heat for a long cooking time.

Types of Surface Burners

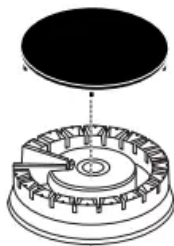

Round Burner

Use this burner for general cooking purposes.
Size cookware appropriately to the flames.



Oval Burner (on some models)

Use this burner to cook on the griddle.

Top-of-Range Cookware

- Aluminum: Medium-weight cookware is recommended because it heats quickly and evenly. Most foods brown evenly in an aluminum skillet. Use saucepans with tight - fitting lids when cooking with minimum amounts of water.
- Stainless Steel: This metal alone has poor heating properties and is usually combined with copper, aluminum or other metals for improved heat distribution. Combination metal

skillets usually work satisfactorily if they are used with medium heat or as the manufacturer recommends.

- Cast-Iron: If heated slowly, most skillets will give satisfactory results.
- Enamelware: Under some conditions, the enamel of some cookware may melt. Follow the cookware manufacturer's recommendations for cooking methods.
- Glass: There are two types of glass cookware - those for oven use only and those for top-of-range cooking (saycepan, coffee and teapots) very slowly.
- Heatproof Glass Ceramic: Can be used for either surface or oven cooking. It conducts heat very slowly and cools very slowly. Check the cookware manufacturer's directions to be sure it can be used on gas ranges.

Stove Top Grills

- Do not use an after-market stove top grill on your gas surface burners. A stove top grill will cause incomplete combustion resulting in carbon monoxide levels above allowable standards. This could be hazardous to your health.



Do not use stove top grills

Using a Wok

- Use only a flat - bottomed wok with a diameter of 14 inches or less. Make sure the wok bottom sits flat on the grate.
- Do not use a wok support ring. Placing the ring over the burner or grate may cause the burner to work improperly, resulting in carbon monoxide levels above allowable standards. This could be hazardous to your health.



Use a flat-bottomed wok.



Griddle (on some models)

Using Your Nonstick Aluminum Griddle (on some models)

Your griddle provides an extra-large cooking surface for meats, pancakes, and other foods usually prepared in a skillet. Before first use, rinse with hot water and dry thoroughly.

Griddle Precautions

- Do not use oil on the griddle for extended lengths of time. Permanent staining and/or craze lines on the surface could result
- Do not overheat the griddle. Leaving the griddle burner on at Hi for an extended amount of time without food can damage the nonstick coating.
- Use only plastic, nylon, wooden utensils, or SilverStone kitchen tools to prevent marring of the coating.
- Never use knives or cut food on the griddle.
- Do not use metal utensils with sharp points or rough, sharp edges which might damage the griddle surface.
- Store carefully to prevent scratching.
- Do not place the griddle in a microwave oven.
- If something has spilled under the griddle, it should be cleaned up as soon as possible to prevent “baked on” food soil.
- Do not allow grease to accumulate under the griddle as it can be a fire hazard. Clean under the griddle with hot, soapy water as soon as it is cool.
- Do not clean your griddle in the dishwasher.
- Do not clean the griddle in the self-cleaning oven. Doing so will damage the nonstick coating. For instructions on how to clean the griddle, see the Cleaning the Cooktop section of this manual.

Nonstick Aluminum Griddle

Type of Food	Cook Setting
Bacon	Med
Breakfast Sausage Links	Med
Fried Eggs	Lo
Hamburgers	Med-Hi
Hot Sandwiches (such as Grilled Cheese)	Med
Pancakes	Med-Lo
Warming Tortillas	Med-Lo



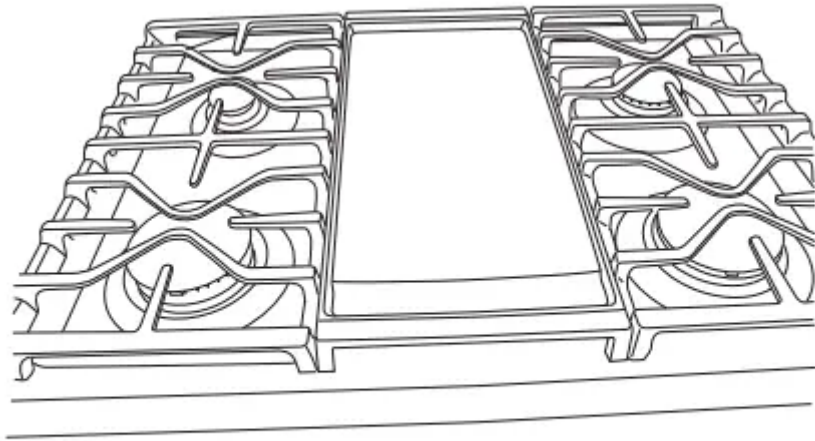

Replace the center grate (if present) with the
Nonstick Aluminum Griddle

Oven Controls

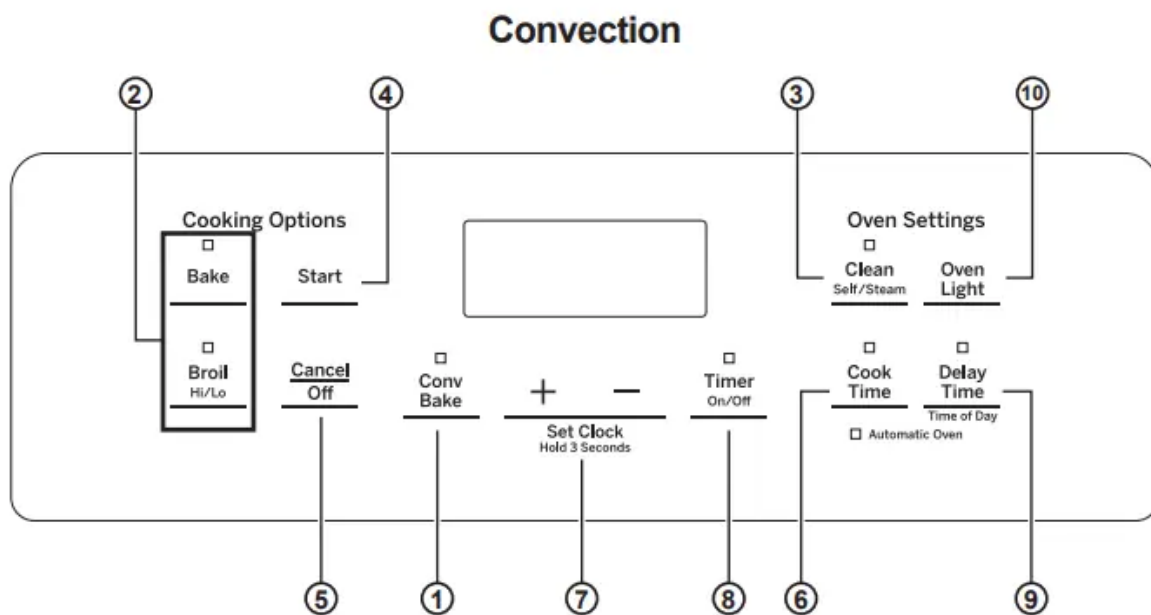
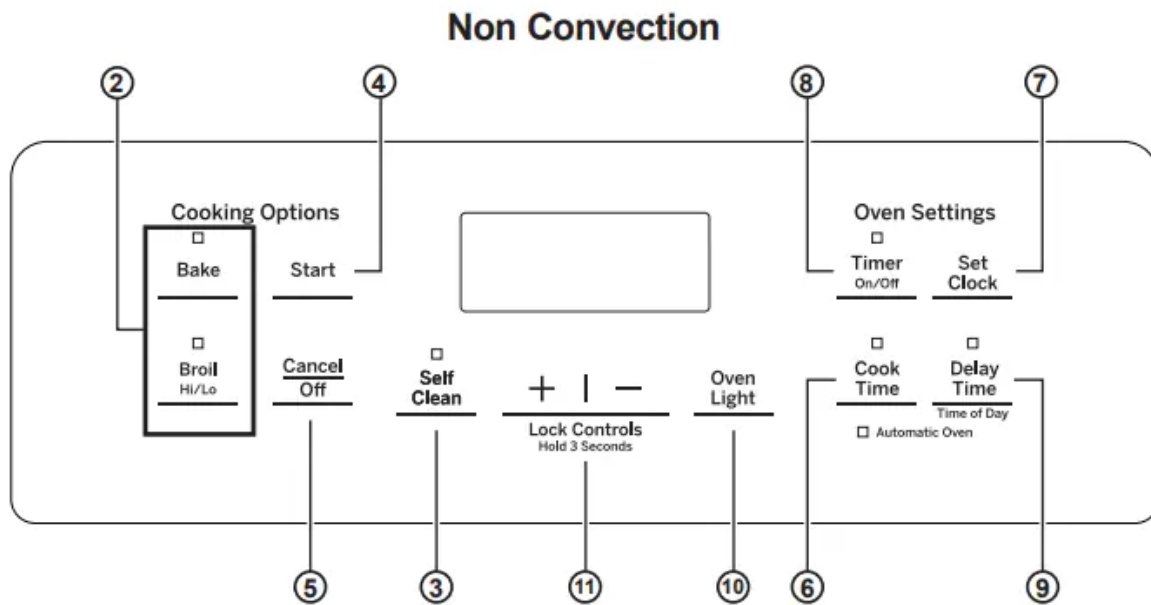

1. Convection Bake (on some models): Convection cooking uses increased air circulation to improve performance when baking on multiple racks. See the Cooking Modes section for more information.
2. Traditional Cooking Modes: Your oven has the following traditional cooking modes: Bake, Broil Hi and Broil Lo. See the Cooking Modes section for more information.
3. Clean (on some models): There are two cleaning modes: Self Clean and Steam Clean. See the Cleaning the Oven section for important information about using these modes.

4. Start: Must be pressed to start any cooking, cleaning or timed function.

5. Cancel/Off: Cancels ALL oven operations except the clock and timer.

6. Cook Time: Counts down cooking time and turns off the oven when the cooking time is complete.

Program the desired cooking time is complete and press Start. Then, press the Cook Time pad and use the number pads to program a cooking time in hours and minutes. Then, press Start again. This can only be used with Traditional Bake and Convection Bake.

7. Clock: Sets the oven clock time and clock display (on some models). To set the clock display (on/ off) press the Set Clock pad (on some models) once. If your model does not have a Set Clock pad, see the Special Features section for instructions on how to adjust the clock display. To set the clock time, press both the + and - pads and hold for 3 seconds or press the Set Clock pad until the display is flashing. Use the + and - pads to adjust the clock. Press Start to save the time.

8. Timer: Works as a countdown timer. Press the timer pad and the + and - pads to program the time in hours and minutes. Press the Start pad. The oven will continue to operate when the timer countdown is complete. To turn the timer off, press the Timer pad.

9. Delay Time:

- Delays when the oven will turn on. Use this to set a time when you want the oven to start. Press the Delay Time pad, and use the + and - pads to program the time of day for the oven to turn on. Then press the desired cooking mode pad, use the + and - pads to adjust the temperature, then press Start. After Start has been pressed, a cook time may also be programmed if desired. Once the Delay Time has been programmed, the start time set for the oven will be displayed until that time is reached. Then, either the cook time (if programmed) or the temperature will be displayed. Delay Time can only be used with Traditional Bake, Convection Bake, and the Clean modes (on some models).
- NOTE: When using the delay time feature, foods that spoil easily—such as milk, eggs, fish, stuffings, poultry, and pork—should not be allowed to sit at room temperature for more than 1 hour before or after cooking, as this may promote the growth of harmful bacteria. Be sure that the oven light is off, because heat from the bulb will speed harmful bacteria growth.

10. Oven Light (on some models): oven light on or off.

11. Lock Controls (on some models): Locks out the control so that pressing the pads does not activate the controls. Press and both the + and - pads and hold for 3 seconds to lock or unlock the control. Cancel/Off is always active, even when the control is locked.

CARE AND CLEANING

Range – Exterior

Be sure all controls are off and all surfaces are cool before cleaning any part of the range

WARNING: If your range is removed for cleaning, servicing or any reason, be sure the anti-tip device is reengaged properly when the range is replaced. Failure to take this precaution could result in tipping of the range and can result in death or serious burns to children or adults.

Control Lockout

- If desired, the touch pads may be deactivated before cleaning.
- See Lock Controls in the Oven Controls section in this manual.
- Clean up splatters with a damp cloth.
- You may also use a glass cleaner. R
- Remove heavier soil with warm, soapy water. Do not use abrasives of any kind.
- Reactivate the touch pads after cleaning.

Control Panel

- It's a good idea to wipe the control panel after each use. Clean with mild soap and water or vinegar and water, rinse with clean water and polish dry with a soft cloth.
- Do not use abrasive cleansers, strong liquid cleansers, plastic scouring pads or oven cleaners on the control panel - they will damage the finish, including Black Stainless Steel.

Oven Exterior

- Do not use oven cleaners, abrasive cleansers, strong liquid cleansers, steel wool, plastic scouring pads, or cleaning powders on the interior or exterior of the oven. Clean with a mild soap and water or vinegar and water solution. Rinse with clean water and dry with a soft cloth. When cleaning surfaces, make sure that they are at room temperature and not in direct sunlight.
- If stain on the door vent trim is persistent, use a mild abrasive cleaner and a sponge-scrubber for best results.
- Spillage of marinades, fruit juices, tomato sauces and basting liquids containing acids may cause discoloration and should be wiped up immediately. Let hot surfaces cool, then clean and rinse.

Painted Surfaces

- Painted Surfaces include the sides of the range and the door, top of control panel and the drawer front. Clean these with soap and water or a vinegar and water solution.

- Do not use commercial oven cleaners, cleaning powders, steel wool or harsh abrasives on any painted surface, including Black Stainless Steel.

Stainless Steel excluding Black Stainless Steel (on some models)

- Do not use a steel wool pad; it will scratch the surface.
- Cleaners with oxalic acid such as Bar Keepers Friend Soft Cleanser™ will remove surface rust, tarnish and small blemishes. Use only a liquid cleanser free of grit and rub in the direction of the brush lines with a damp, soft sponge.
- To clean the stainless steel surface, use warm sudsy water or a stainless steel cleaner or polish. Always wipe the surface in the direction of the grain. Follow the cleaner instructions for cleaning the stainless steel surface.
- To inquire about purchasing cleaning products including stainless steel appliance cleaner or polish, see the Accessories and Consumer Support sections at the end of this manual.

Range – Interior

The interior of your new oven can be cleaned manually or by using Self Clean mode.

Spillage of marinades, fruit juices, tomato sauces and basting liquids containing acids may cause discoloration and should be wiped up immediately. Let hot surfaces cool, then clean and rinse.

Manual Cleaning

- Do not use oven cleaners, strong liquid cleansers, steel wool, or scouring pads on the interior of the oven. For soils on the oven bottom and other enameled surfaces, use a gentle abrasive containing oxalic acid, such as Bar Keepers Friend®, with a non-scratch sponge. Take care not to apply any abrasive cleaners or sponges to the door glass, as it will scratch the reflective coating. The oven interior and door glass may be cleaned using a soft cloth with a mild soap and water, or vinegar and water solution. After cleaning, rinse with clean water and dry with a soft cloth.

Steam Clean Mode

The Steam Clean feature is for cleaning light soil from your oven at a lower temperature than Self Clean.

To use the Steam Clean feature:

1. Start with the oven at room temperature.
2. Wipe excess grease and soils from the oven.
3. Pour one cup of water onto the bottom of the oven
4. Close the door.
5. Press the **Clean** pad, select **Steam Clean** and then press **Start/Enter**. 30 minutes will show and count down in the display in the **Steam Clean** mode.

If your range has the self clean mode below, slide the door latch handle to the left as far as it will go. Do not open the door during the 30 minute Steam Clean cycle. At the end of the Steam Clean cycle, soak up the remaining water, and wipe the moisture-softened soil from the oven walls and door.

Racks

All racks can be washed with warm, soapy water. Enameled (not shiny) racks can be left in the cavity during self clean.

Racks may be more difficult to slide, especially after a self-clean. Put some vegetable oil on a soft cloth or paper towel and rub onto the left and right edges.

Cooktop

Removal of Surface Burners for Cleaning

- Turn all controls OFF. Allow cooktop to cool before removing grates and burner parts. When removing the burner caps and heads, remember their size and location. Replace them in the same location after cleaning.
- CAUTION: Do not attempt to remove oval burner cap from burner head.

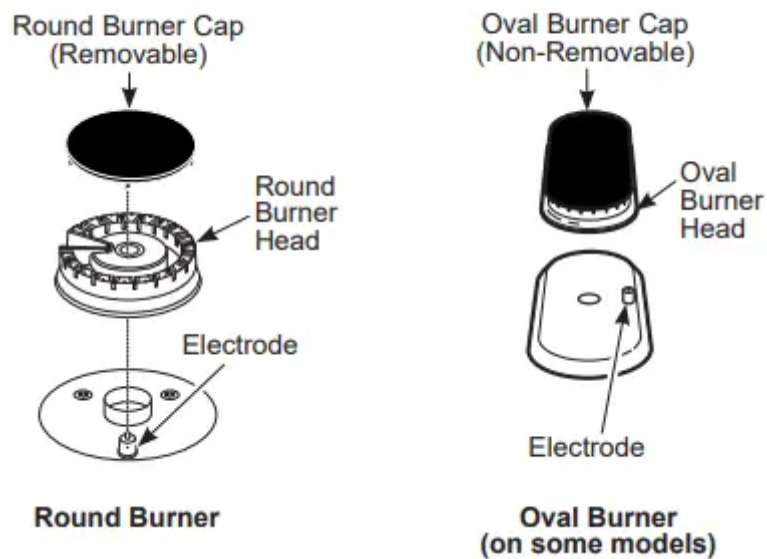

Cleaning the Surface Burners

Cleaning the Burner Caps

- Wash burner caps in hot, soapy water and rinse with clean water. You may scour with a plastic scouring pad to remove burned-on food particles. The round burner caps may also be cleaned in your dishwasher.

Cleaning the Burner Heads

- Wash the burner heads routinely, especially after bad spillovers which could clog the burner openings. Lift burners off when cool. Wash with hot, soapy water. Rinse with clean water. For more stubborn stains, use a brush with plastic bristles.
- NOTE: Do not use steel wool or scouring pads to clean the burner parts as these may clog the openings. Never wash burner heads in your dishwasher as dishwasher. Doing so may cause them to discolor.
- The ports in the burner heads must be kept clean at all times for an even, unhampered flame.
- Clogged or dirty burner ports or electrodes will not allow the burner to operate properly.

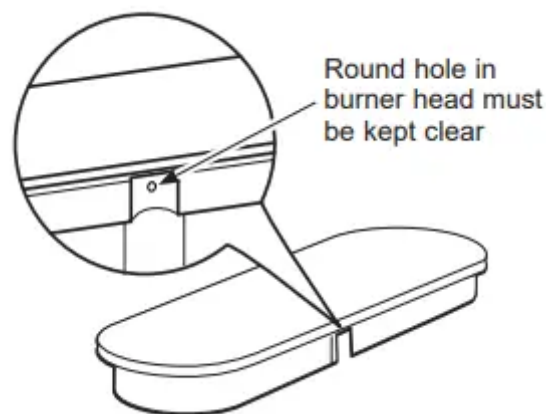

Replacing Surface Burners

- Before replacing the burner caps, heads and oval head/ cap assembly, shake out excess water and allow them to dry thoroughly.
- Replace burner heads in the correct locations according to size. Ensure each cap is properly seated on the burner head, as pictured below.



CAUTION: Do not operate the cooktop without all burner parts and grates in place.

Any spill on or around an electrode must be carefully cleaned. Avoid hitting the electrode with anything hard or it could be damaged.

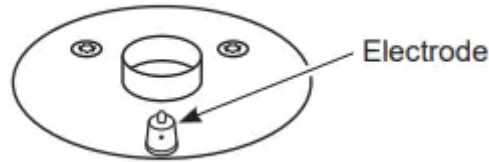

The electrode of the spark igniter is exposed when the burner head is removed. When one burner is turned to LITE, all the burners spark. Do not attempt to disassemble or clean around any burner while another burner is on.

Burner Grates

Manual Cleaning

- Grates should be washed in hot, soapy water and rinsed with clean water. To soften burned-on food, place grates in a solution containing $\frac{1}{4}$ -cup of household ammonia for several hours. Afterward, scrub grates with a plastic scouring pad soaked in hot, soapy water. Rinse well and dry

Self Clean Mode (on some models)

- If your grates do not have rubber bumpers on their bottom surface, they may be cleaned in the oven using the self-clean cycle. Do not attempt to clean your grates in the oven if your grates have rubber bumpers. Doing so will destroy the rubber bumpers and may affect the function of your surface burners.
- Poreclain - coated grates may gradually dull if continually exposed to self-clean temperatures.
- Your oven equipped with nickel - plated (silver) racks, it is recommended to follow the instructions for placing grates on the oven bottom. Nickel-plated racks should not remain in the oven during the self clean cycle. Doing so will tarnish the racks. If either type of rack is left in the oven during a self-clean cycle, the rack may become difficult to slide.
- NOTE: When placing or removing grates from the oven, do not slide the grates on the racks or oven bottom. Doing so could damage the enamel on the racks or oven bottom.

To self clean your grates on the oven bottom:

1. Remove all oven racks
2. Gently place one grate on the center of the oven bottom with the grate oriented in the upright position. Stack remaining grates as shown below. Do not place or stack grates in any other configuration.

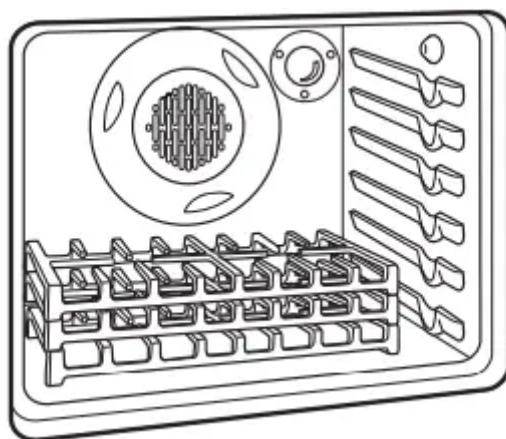

Once the grates are placed in the oven, operate the self-clean cycle per the instruction in the Cleaning the Oven section.

NOTE: Use caution when removing the grates from the oven after the self-clean cycle has ended. The grates may still be hot.

Once the self-clean cycle is complete, the grates may carefully be removed. You may notice a white residue on the grates. Wipe it off with a damp sponge. If white spots persist, wet the sponge with a 50/50 solution of vinegar and water and wipe the grates again.

When replacing the grates on the cooktop, be sure to locate them correctly. Grates should fit securely into the cooktop.

Grate Support Bumpers (on some models)

- If any of the rubber grate support bumpers in the cooktop are missing or damaged, replacement parts can be obtained by calling GE Appliances
- To insert the new bumpers, simply place the coneshaped end of the bumper into the hole in the cooktop and push down while gently twisting the bumper.

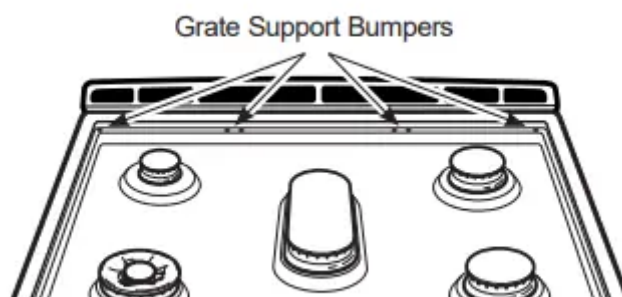

Griddles (on some models)

Nonstick Aluminum Griddle: Avoid scraping the griddle surface with metal utensils. Wash your griddle with dish soap and hot water. If necessary, scrub with a nonabrasive plastic pad.

Griddle Precautions:

- If something has spilled under the griddle, it should be cleaned up as soon as possible to prevent the spill from getting baked onto the cooktop.
- Do not allow grease to accumulate under the griddle as it can be a fire hazard. Clean under the griddle with hot, soapy water as soon as it is cool.
- Do not wash your griddle in the dishwasher.
- Do not clean the griddle in the self cleaning oven

Door and Drawer

Cleaning the Oven Door

Cleaning the Door Interior

- Do not allow excess water to run into any holes or slots in the door
- Wipe dish soap over any baked-on spatters on the glass. Use a single sided safety razor blade to clean it off . Then wipe over the glass with a soapy cloth to remove any residue and dry off.
- The area outside the gasket can be cleaned with a soapfilled plastic scouring pad. Do not rub or clean the door gasket - it has an extremely low resistance to abrasion.
- If you notice the gasket becoming worn, frayed or damaged in any way or if it has become displaced on the door, you should have it replaced.

Cleaning the Door Exterior

- If a stain on the door vent trim is persistent, use a mild abrasive cleaner and a sponge-scrubber for best results. Do not use this method on any other surface.

Stainless Steel Surfaces (on some models)

- Do not use a steel wool pad; it will scratch the surface.
- To clean the stainless steel surface, use warm sudsy water or a stainless steel cleaner or polish. Always wipe the surface in the direction of the grain. Follow the cleaner instructions for cleaning the stainless steel surface.
- To inquire about purchasing cleaning products including stainless steel appliance cleaner or polish, see the Accessories and Consumer Support sections at the end of this manual.

Removable Storage Drawer (on some models)

The storage drawer is a good place to store cookware and bakeware. Do not store plastics or flammable material in the drawer.

The storage drawer may be removed for cleaning under the range. Clean the storage drawer with a damp cloth or sponge. Never use harsh abrasives or scouring pads.

Removing the Storage Drawer:

1. Pull drawer straight out until it stops
2. Tilt the front of the drawer upward and pull the drawer free of the range.

Replacing the Storage Drawer:

1. Reset the drawer slides on the range stops
2. Push directly backward until the drawer drops into place.
3. Slide the drawer all the way into the oven.

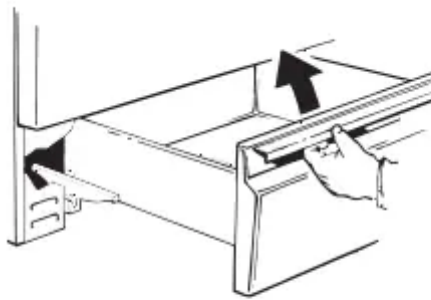

The storage drawer may be removed for cleaning under the range.

Oven Light

SHOCK OR BURN HAZARD: Before replacing oven light bulb, disconnect the electrical power to the range at the main fuse or circuit breaker panel. Failure to do so may result in electric shock or burn.

CAUTION - BURN HAZARD: The glass cover and bulb should be removed when cool. Touching hot glass with bare hands or a damp cloth can cause burns.

NOTE: The glass cover should be removed only when cold. Wearing latex gloves may offer a better grip.

Before replacing the bulb, disconnect electrical power to the oven at the main fuse or circuit breaker panel. Let the bulb cool completely before removing it. For your safety do not touch a hot bulb with a damp cloth. If you do the bulb may break.

To remove: Turn the glass cover counterclockwise 1/4 turn until the tabs of the glass cover clear the grooves of the socket and pull the cover off. Remove the bulb.

To replace: Put in a new 40 watt appliance bulb. Place the tabs on the glass cover into the grooves of the socket. Turn the glass cover clockwise 1/4 turn.

NOTE:

- A 40 watt appliance bulb is smaller than a standard 40 watt household bulb.
- Reconnect electrical power to the oven once the new bulb is installed.
- For improved lighting inside the oven, clean the glass cover frequently using a wet cloth. This should be done when the oven is completely cool.

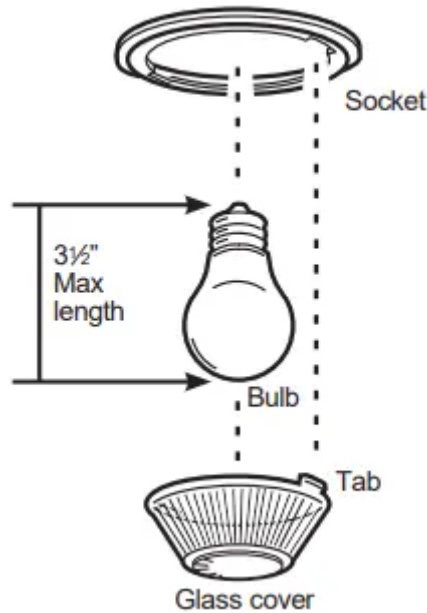

CAUTION

- Before replacing your oven light bulb, disconnect the electrical power to the range at the main fuse or circuit breaker panel. Be sure to let the light cover and bulb cool completely.
- The oven light bulb is covered with a removable glass cover that is held in place with a bail-shaped wire. Remove the oven door, if desired, to reach the cover easily. See the Lift-Off Oven Door section for detailed oven door removal instructions.

Replacing the Light Bulb (JGSS66 model only):

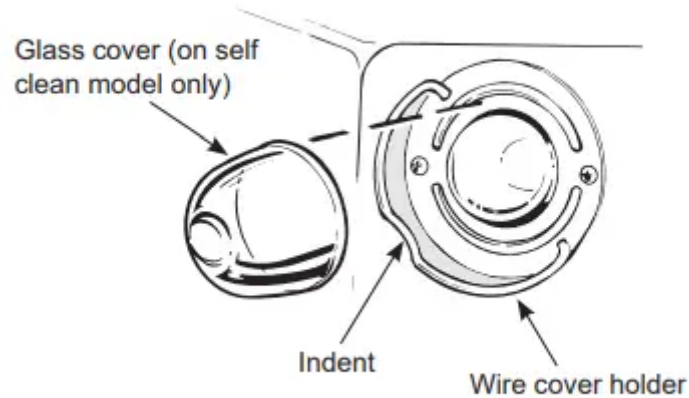

1. Disconnect electrical power to the range.
2. Hold the glass cover stable, so it doesn't fall when released.
3. Slide near the indent of the cover holder until the cover is released. Do not remove any screws to release the glass cover.
4. Replace bulb with a 40-watt household appliance bulb. Do not touch hot bulb with hand or wet cloth. Only remove bulb when it is cool.
5. Hold glass cover stable over new bulb.
6. Pull the wire cover holder near the indent until the indent in the wire cover holder is located in the indent of the glass cover.
7. Connect electrical power to range.

Oven Door

The door is very heavy. Be careful when removing and lifting the door. Do not lift door by the handle.

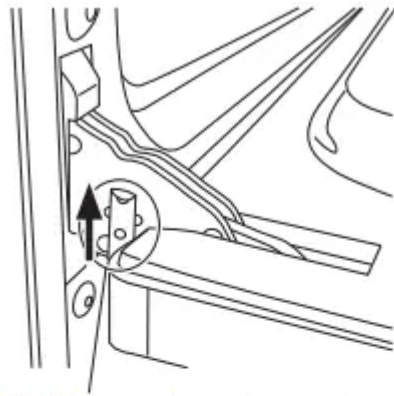

Pull hinge locks up to unlock

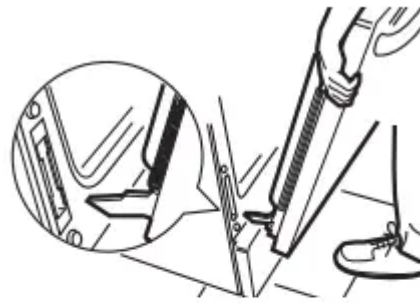

Removal position

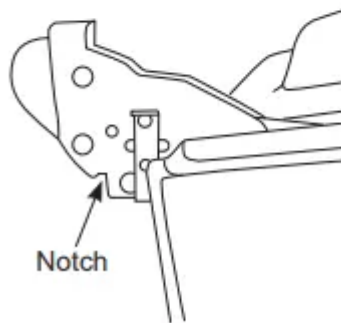

Notch

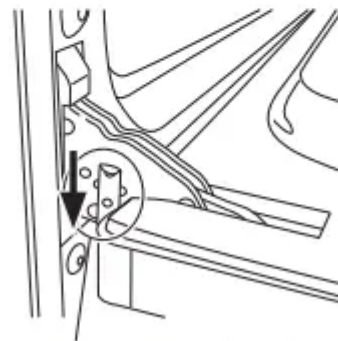

Push hinge locks down to lock

Removing the Door:

1. Fully open the oven door
2. On each hinge, slide the hinge lock up, making sure it snaps into its fully raised position.
3. Firmly grasp both sides of the door near the handle.
4. Close the door until the top of the door is approximately 3" from the range frame.
5. Lift door up and away from the range until both hinge arms are clear of the slots in the range frame

Replacing the Door:

1. Firmly grasp both sides of the door near the handle
2. With the door at the same angle as the removal position, rest the notch in the bottom of the left hinge arm on the bottom edge of the left hinge slot. The notch in the hinge arm must be fully seated onto the bottom of the slot. Repeat for the right side.
3. Fully open the door. If the door will not fully open, the hinge arms are not seated correctly. Lift the door off the range and repeat Step 2.
4. Push the hinge locks down to the locked position
5. Close the oven door.

The door is very heavy. Be careful when removing and lifting the door. Do not lift door by the handle.

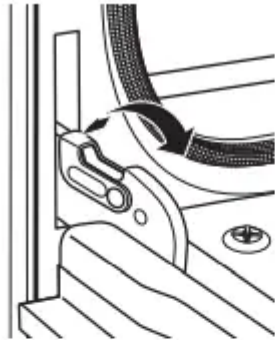

Pull hinge locks up to unlock



Removal position

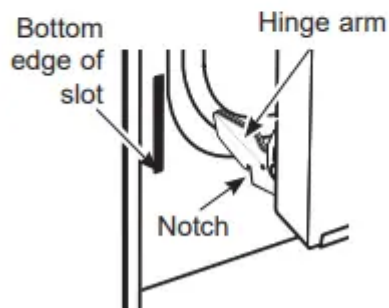

Rest notch on bottom edge of hinge slot



Push hinge locks down to lock

To Remove the Door (JGSS66 model only):

1. Fully open the oven door
2. Pull the hinge locks up and away from the range frame to the unlocked position.
3. Firmly grasp both sides of the door near the top.
4. Close door until the top of the door is approximately 6" from the range frame.
5. Lift door up and away from the range until both hinge arms are clear of the slots in the range frame.

To Replace the Door (JGSS66 model only):

1. Firmly grasp both sides of the door near the top
2. With the door at the same angle as the removal position, rest the notch on the underside of the left hinge arm on the bottom edge of the left hinge slot. The notch in the hinge arm must be fully seated into the bottom of the slot. Repeat for the right side.
3. Fully open the door. If the door will not fully open, the notches in the bottoms of the hinge arms have not seated correctly in the bottom edge of the slot. Lift the door off the range and repeat previous step.

4. Push the hinge locks toward the range cavity and down to the locked position.
5. Close the oven door.

Troubleshooting Tips

... Before you call for service

Save time and money! Review the charts on the following pages first and you may not need to call for service.

1. My new oven doesn't cook like my old one. Is something wrong with the temperature settings?

Your new oven has a different cooking system from your old oven and therefore may cook differently than your old oven.

- For the first few uses, follow your recipe times and temperatures carefully and use rack positions recommended in the Cooking Guide. If you still think your new oven is too hot or too cold, you can adjust the temperature yourself to meet your specific cooking preference. See the Oven Controls section

2. Food does not bake properly

- Oven controls improperly set. See the Cooking Modes section.
- Rack position is incorrect or rack is not level. See the Cooking Modes section and Cooking Guide.
- Incorrect cookware or cookware of improper size being used. See the Cookware section.
- Oven temperature needs adjustment. See the Oven Controls section

3. Food does not broil properly

- Oven controls improperly set. Make sure you select the appropriate broil mode.
- Improper rack position being used. See Cooking Guide for rack location suggestions.
- Cookware not suited for broiling. Use a pan specifically designed for broiling
- Aluminum foil on the broil pan has not been fitted properly or slit to drain grease. If using aluminum foil on broil pan, wrap tightly and add slits conforming to those in the pan to allow grease to drain.

4. Oven temperature too hot or too cold

- Oven temperature needs adjustment. See the Oven Controls section.

5. Oven and/or display appears not to work

- A fuse in your home may be blown or the circuit breaker tripped. Replace the fuse or reset the circuit breaker
- Oven controls improperly set. See the using the oven section

- Oven is in Sabbath Mode. Verify, that the oven is not in Sabbath Mode. See the Special Features section.
- The clock is turned off. See the Oven Controls or Special Features section

6. “Crackling” or “popping” sound

- This is the sound of the metal heating and cooling during both the cooking and cleaning functions. This is normal.

7. Why is my range making a "clicking" noise when using my oven?

- Your range has been designed to maintain a tighter control over your oven's temperature. You may hear your oven's heating elements 'click' on and off more frequently than in older ovens to achieve better results during baking, broiling, and self-clean cycles. This is normal.

8. Clock and timer do not work

- A fuse in your home may be blown or the circuit breaker tripped. Replace the fuse or reset the circuit breaker.

9. Sometimes the oven takes longer to preheat to the same temperature

- Cookware, food, and/ or number of racks in oven. Cookware, food, and racks in the oven will cause differences in preheat times. Remove excess items to reduce preheat time.

10. Oven light does not work

- Light bulb is loose or defective. Tighten or replace bulb. See the Maintenance section for instructions on how to replace the bulb

11. Oven will not selfclean

- The temperature is too high to set a self-clean operation. Allow the oven to cool and reset the controls.
- Oven controls improperly set. See the Care and Cleaning section.

12. Excessive smoking during clean cycle

- Excessive soil or grease. Turn the Oven Temperature Knob to OFF. Wait until the Oven cools below the unlocking temperature. Open the windows to rid the room of smoke. Wipe up the excess soil and reset the clean cycle.

13. Oven not clean after a clean cycle

- Oven controls improperly set. See the Care and Cleaning section.
- Oven was heavily soiled. Clean up heavy spillovers before starting the clean cycle. Heavily soiled ovens may need to self-clean again.

14. Strong “burning” or “oily” odor emitting from the vent

- This is normal in a new oven and will disappear in time. To speed the process, set a self-clean cycle. See the Care and Cleaning section. This is temporary

15. Excessive smoking during broiling

- Food too close to burner element. Lower the rack position of the food.

16. Oven door will not open when you want to cook.

- The oven door is locked because the temperature inside the oven has not dropped below the locking temperature. Allow the oven to cool below the locking temperature.

17. "LOCK DOOR" flashes in the display

- The self-clean or steam-clean cycle has been selected but the door is not locked. Lock the oven door.

18. “F— and a number or letter” flash in the display

- You have a function error code.
Press the Cancel/Off pad. Allow the oven to cool for one hour. Put the oven back into operation. If the function code repeats, disconnect all power to the oven for at least 30 seconds and then reconnect power. If the function error code repeats again, call for service.

19. Clock flashes due to a power outage

- Power outage or surge. Reset the clock. If the oven was in use, you must reset it by pressing the Cancel/Off pad, setting the clock and resetting any cooking function.

20. Lock Controls or Control Lockout feature is activated

- If LOC ON appears in the display, the range control is locked. Turn this feature off to use the range. See the Oven Controls section.

21. Burners do not light

- Plug on range is not completely inserted in the electrical outlet. Make sure electrical plug is plugged into a live, properly grounded outlet.
- Gas supply not connected or turned on. See the Installation Instructions that came with your range.
- A fuse in your home may be blown or the circuit breaker tripped. Replace the fuse or reset the circuit breaker.
- Burner parts not replaced correctly. See the Care and Cleaning of the range section.
- Burner slots near the electrode, or the round lighter port on the oval burner, may be clogged. Remove the burners and clean them. Check the electrode area for burned-on food or grease. See the Care and Cleaning of the range section.

- Food residue on electrode Lightly polish flat tip of electrode with nail file or sandpaper until shiny

22. Top burners do not burn evenly

- Improper burner assembly. Make sure the burner caps are seated correctly. See the Care and Cleaning of the range section.
- Burner slots on the side of the burner may be clogged. Remove the burners for cleaning. See the Care and Cleaning of the range section.

23. Burner flames are very large or yellow

- Improper air to gas ratio. If range is connected to propane gas, contact the technician who installed your range or made the conversion.

24. Surface burners light but bake and broil burners do not.

- Gas to the oven burners may have been shut off. The oven gas shut-off is located on the gas regulator near the gas line attachment to your range. Locate it and flip the lever.

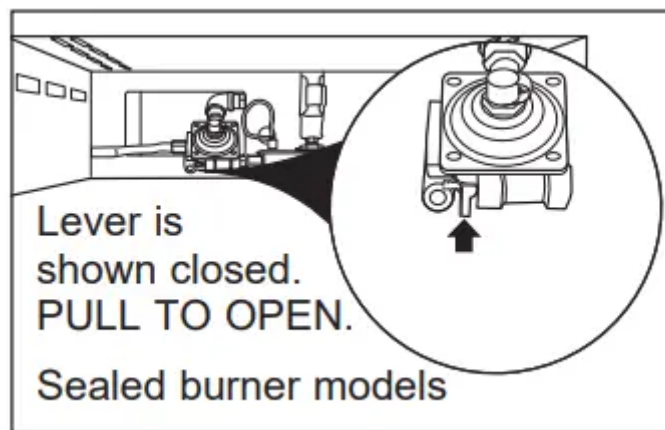

25. My oven door glass appears to be "tinted" or have a "rainbow" color.

- The inner oven glass is coated with a heat barrier to reflect the heat back into the oven to prevent heat loss and keep the outer door cool while baking. This is normal. Under certain light or angles, you may see this tint or rainbow color.

26. Drawer does not slide smoothly or drags

- The drawer is out of alignment. Fully extend the drawer and push it all the way in. See the Care and Cleaning of the range section.
- Drawer is over-loaded or load is unbalanced. Reduce weight or redistribute drawer contents.

Warning

This content is compiled from multiple sources and is provided for reference purposes only. It may not be complete or fully applicable to all situations. If you are unable to resolve your issue, please contact the product manufacturer or an authorized service provider for official support.

Document generated by [ManualsFile](#)

