

## Installation

Follow these instructions carefully to ensure a proper installation of this refrigerator and to prevent accidents before using it.



### WARNING

- Use the refrigerator only for its intended purpose as described in this manual.
- Any servicing must be performed by a qualified technician.
- Dispose of the product packaging material in compliance with the local regulations.
- To prevent electric shock, unplug the power plug before servicing or replacing parts.

### Refrigerator at a glance

The actual refrigerator and provided parts of your refrigerator may differ from the illustrations in this manual, depending on the model and the country.

#### Type A

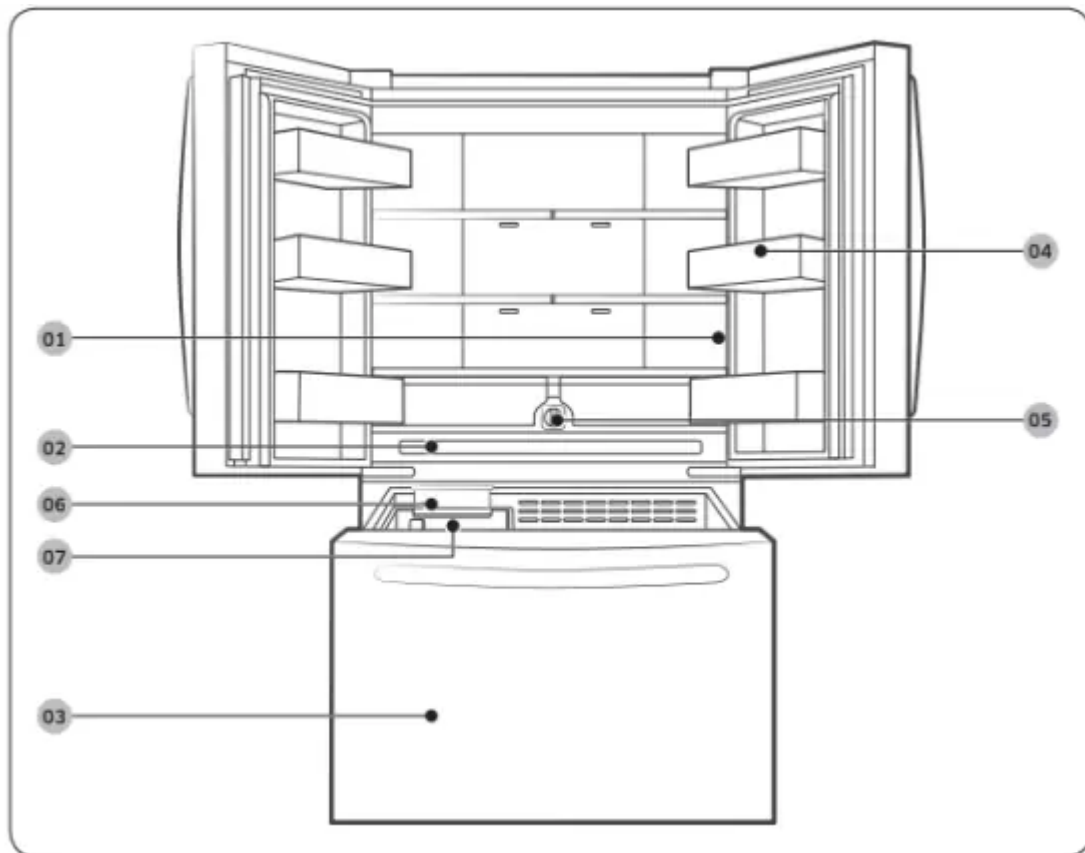

#### Type B

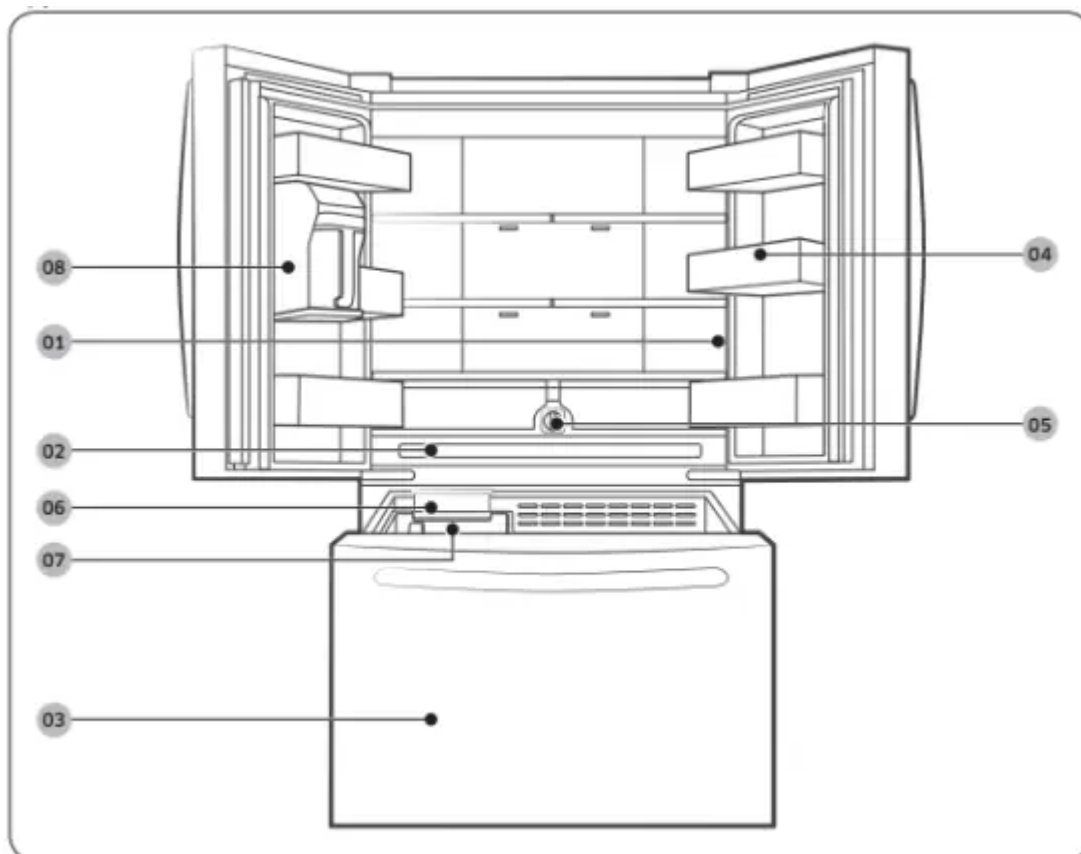

**NOTE**

- For energy efficiency, keep all shelves, drawers, and baskets in their original positions.
- When closing the door, make sure the vertical hinged section is in the correct position to avoid scratching the other door.
- If the vertical hinged section is reversed, put it back into the correct position, and then close the door.
- Moisture may form at times on the vertical hinged section.
- If you close a door forcefully, the other door may open.
- If the internal or external LED lamp is out of order, contact a local Samsung service center.
- If the door is left open for too long, the top internal LED will blink. This is normal.

**Step-by-step installation**

**STEP 1 Select a site**

**Select a site that:**

- Has a solid, level surface without carpeting or flooring that may obstruct ventilation
- Is away from direct sunlight
- Has adequate room for opening and closing the door



- Is away from any heat sources
- Provides room for maintenance and servicing
- Has a temperature range between 50 °F (10 °C) and 109 °F (43 °C)



### **CAUTION**

- If your refrigerator is equipped with an ice maker, provide extra space at the rear of the refrigerator for the water line connection.
- When you install the refrigerator next to a fixed wall, you must provide a minimum clearance of 3 3/4" (95 mm) from the wall to allow the door to swing open.

### **NOTE**

To facilitate moving your refrigerator to its final location, be sure to measure the width and height of doorways, thresholds, ceilings, stairways, and anything else that needs to be taken into consideration to ensure you can move your refrigerator safely. The following diagram illustrates the exact height and depth (factory specifications) of your refrigerator.

### **Clearance**

See the following figures and tables for space requirements for installation.

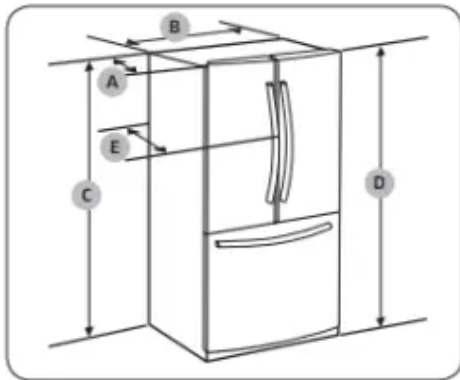

Model	RF28*
Depth "A"	32 7/8" (836 mm)
Width "B"	35 3/4" (908 mm)
Height "C"	68 7/8" (1749 mm)
Overall Height "D"	70" (1777 mm)
Depth "E"	35 3/8" (898 mm)

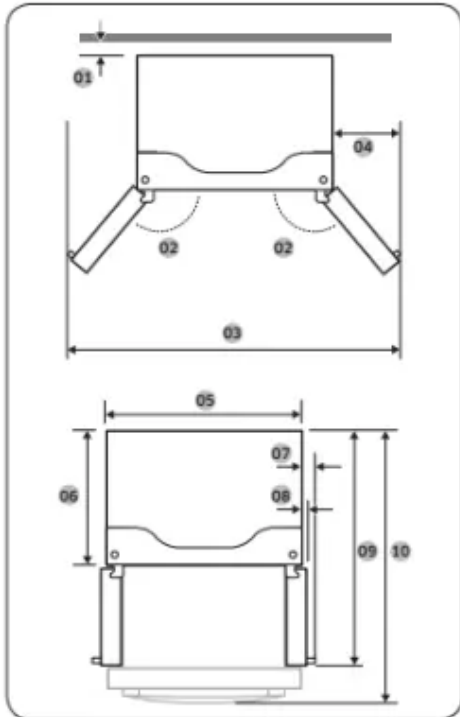

Model	RF28*
01	2" (50 mm)
02	130°
03	62 2/8" (1581 mm)
04	13 2/8" (337 mm)
05	35 3/4" (908 mm)
06	28 7/8" (735 mm)
07	3 5/8" (93 mm)
08	1 7/8" (47 mm)
09	47 2/8" (1201 mm)
10	51 7/8" (1318 mm)

**NOTE**  
The measurements in the table above may differ slightly from the actual measurements, depending on the measuring and rounding method.

## STEP 2 Flooring

If the refrigerator cannot pass through the entrance due to its size, see STEP 3 Door removal for entrance.

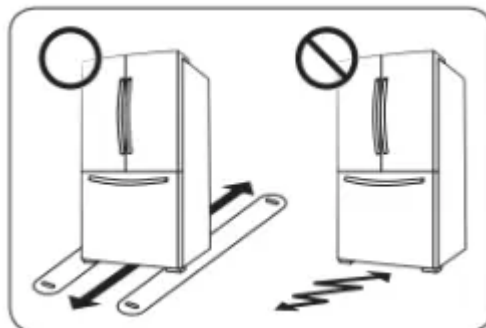

**NOTE**



To prevent floor damage, make sure the front leveling legs are in the upright position.

- The surface you install the refrigerator on must support a fully loaded refrigerator.
- To protect the floor, put a large piece of cardboard along the path to the refrigerator's final installation location.
- Once the refrigerator is in its final position, do not move it unless necessary to protect the floor. If you have to move the refrigerator, place thick paper or cloth such as old carpets along the path of movement.

### **STEP 3 Door removal for entrance**

If the refrigerator cannot pass through the entrance to your home or kitchen due to its size, follow these instructions to remove and then re-install the refrigerator's doors. If you do not need to remove the doors, go to page 29 to continue the installation procedure.



Unplug the power cord of the refrigerator before removing the doors.

#### **Tools required (not provided)**

Tools required (not provided)

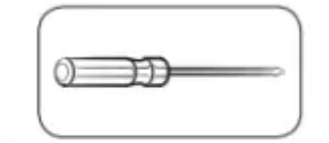

Phillips screwdriver

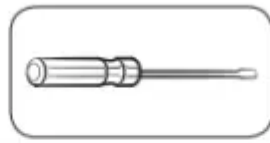

Flat-head screwdriver

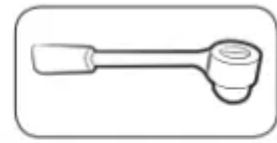

Socket wrench  $\frac{3}{8}$ " (10 mm)

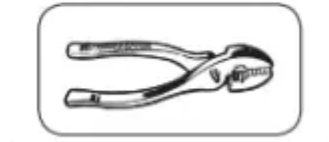

Pliers



Allen wrench  $\frac{1}{4}$ " (5 mm)

#### **Detach the fridge doors**

Left door

1. With the doors closed, use a Phillips head screwdriver to remove the screws x3) in the top cover.

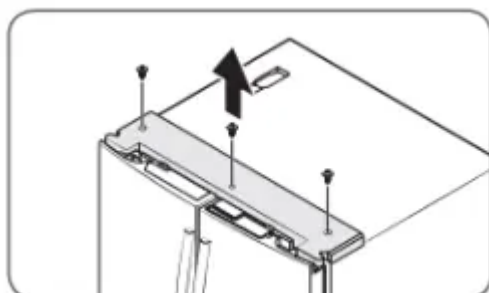

2. Disconnect the wires and the water tube from the left-side door. Do the following sequentially:

- Decouple the connector.
- While holding down one end of the water line coupler, disconnect the water tube.

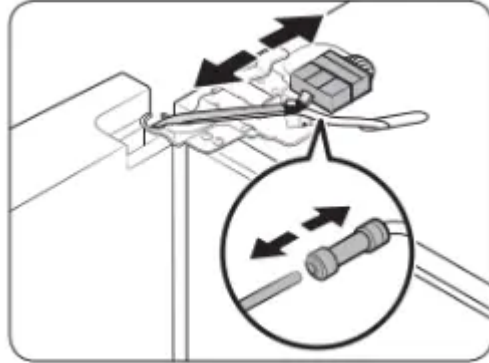

 **CAUTION**

Keep the water tube clips out of children's reach.

3. Gently draw up the clamp. To prevent finger injuries, do not apply a sudden force to the clamp.

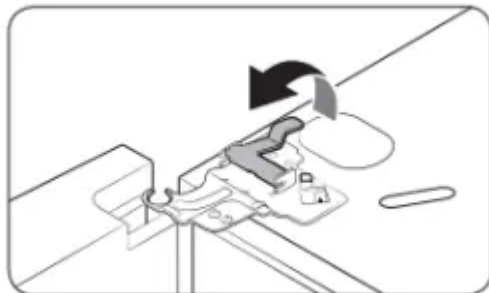

4. Pull the clamp to remove it.

**NOTE**

Be careful not to drop the clamp on the floor.

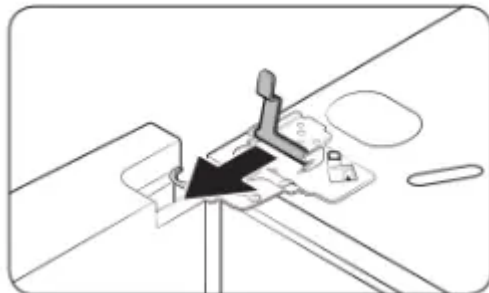

5. Open the door 90 degrees. While holding the door, pull up and remove the top hinge. Be careful not to damage the connector wires when you remove the hinge.

## NOTE

Be careful not to drop the hinge on the floor.

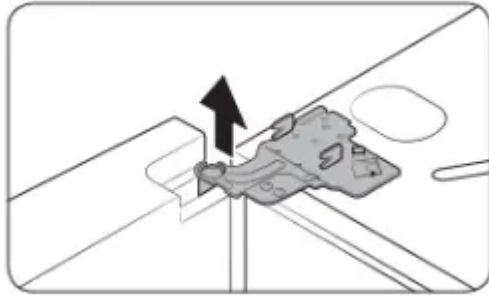

6. Gently pull up the door vertically to remove. Do not apply excessive force to the door. The door may fall, causing physical injury.

7. Lay the door down on a flat surface.

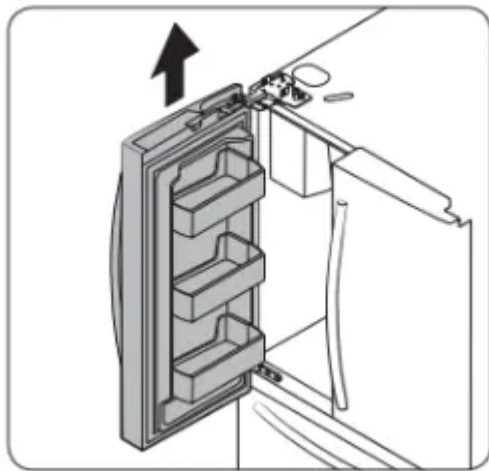

## CAUTION

Please put the door down slowly to prevent scratches.

Right door

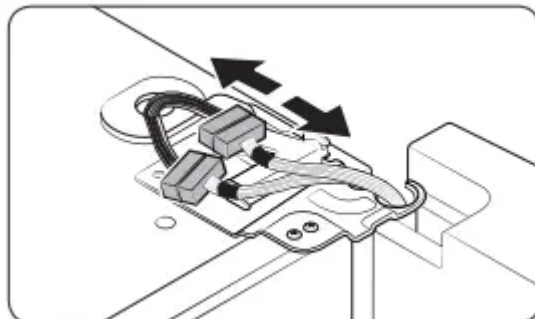

1. Disconnect the wire connectors (x2) on the right door. The position of the connectors differs with the model.

 **CAUTION**

- Do not remove both doors simultaneously. Make sure to remove one door at a time. Otherwise, one of the doors may fall and cause physical injury.
- Make sure the refrigerator is off before disconnecting the connectors.

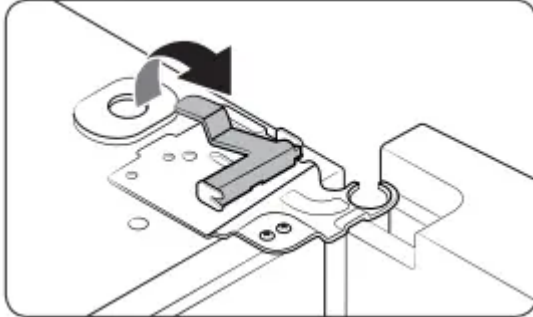

2. Gently draw up the clamp. To prevent finger injuries, do not apply a sudden force to the clamp.

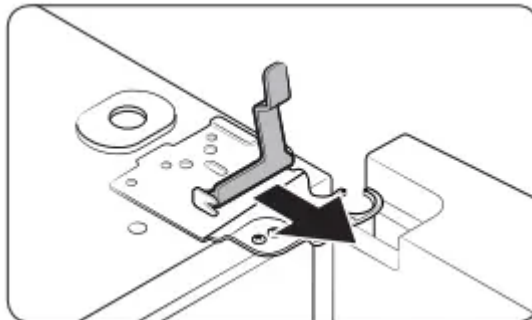

3. Pull the clamp to remove it.

**NOTE**

Be careful not to drop the clamp on the floor.

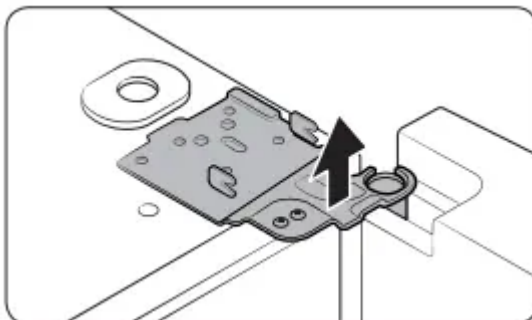

4. Open the door 90 degrees. While holding the door, pull up and remove the top hinge. Be careful not to damage the connector wires when you remove the hinge.

**NOTE**

Be careful not to drop the hinge on the floor.

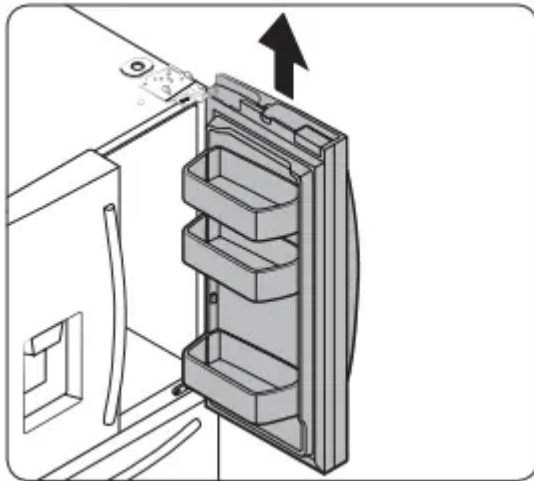

5. Gently pull up the door vertically to remove. Do not apply excessive force to the door. The door may fall, causing physical injury.
6. Lay the door down on a flat surface.

**To reattach the fridge door**

After you have moved the refrigerator to its final location, reattach the doors by following the removal instructions in reverse order.



To prevent water leaks from the dispenser, the water line must be fully connected. Make sure both tubes of the water line are inserted fully to the center of transparent coupler (A) or the guidelines (B).

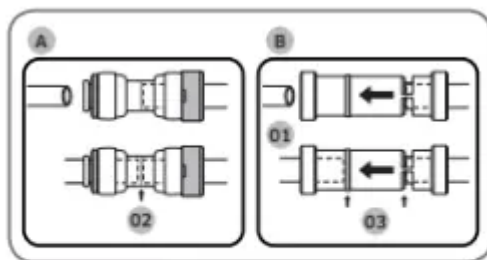

- 01 Dispenser
- 02 Center of transparent coupler
- 03 Guidelines

**To detach the freezer drawer**

1. Lift up the front of the upper basket and pull to remove.



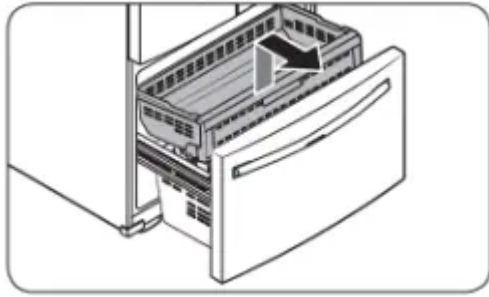

2. Lift the door bin to remove.

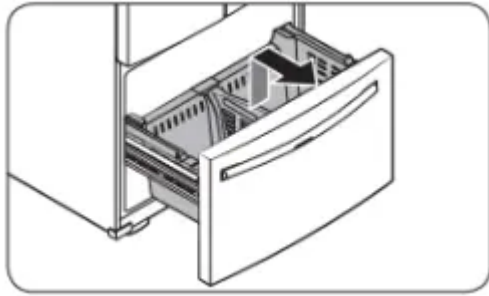

3. Then, pull up to remove the lower basket from the rail assembly.

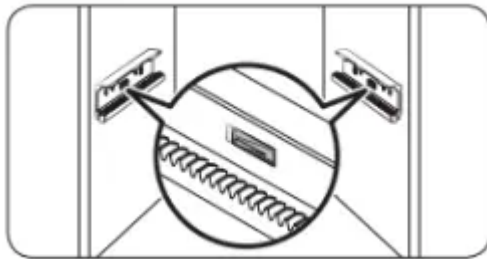

4. Press down the hooks to unlock the rail assembly.

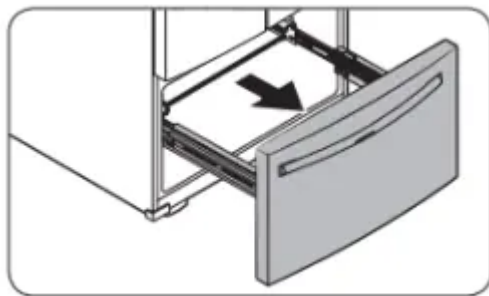

5. While holding the upper area of the freezer drawer front, slide the drawer out all the way to remove the freezer drawer from the rail assembly.

 **CAUTION**

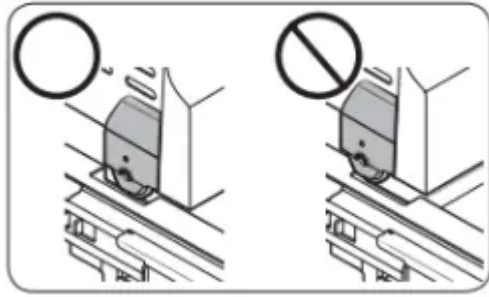

- Be careful not to scratch or dent the rail assembly.
- Make sure you mount the freezer baskets in the correct position. Otherwise, the door will not open or close properly, which causes frost to build up.
- Do not store too much food in the freezer drawer. This prevents the freezer drawer from closing properly, resulting in frost buildup.

#### **To reattach the freezer drawer**

Once the refrigerator is in or near its final location, re-attach the freezer drawer by following the directions in the reverse order of removal.

#### **STEP 4 Leveling the refrigerator**

##### **CAUTION**

- When installed, the refrigerator must be leveled on a flat, solid floor. Not leveling the refrigerator can cause damage to the refrigerator or physical injury.
- Leveling must be performed with the refrigerator empty. Make sure no food items are inside the refrigerator.
- For safety reasons, adjust the front a little higher than the rear.

Level the refrigerator using the special screws (levelers) on the front legs. Use a flat-head screwdriver to turn the levelers.

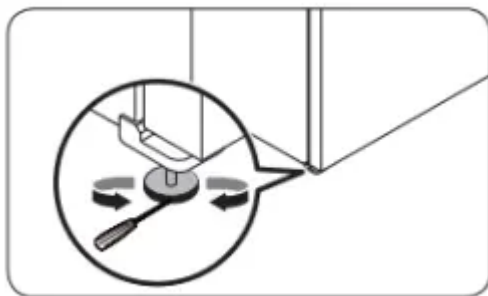

- To adjust the height of the left side: Insert a flat-head screwdriver into the leveler of the left side front leg. Turn the leveler clockwise to raise the left side or turn it counterclockwise to lower.

- To adjust the height of the right side: Insert a flat-head screwdriver into the leveler of the right side front leg. Turn the leveler clockwise to raise the right side or turn it counterclockwise to lower.

### **STEP 5 Adjust the door height and the door gap**

#### **Snap rings**

The height of a door can be adjusted using the provided snap rings, which come in 4 different sizes (1 mm, mm, 2 mm, and 2.5 mm).

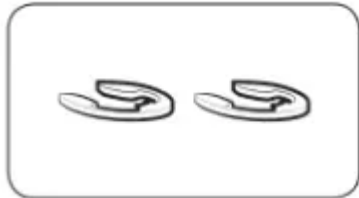

#### **To adjust the height of a door**

1. Check the height difference between the doors, and then lift up and hold the door with the lower height.

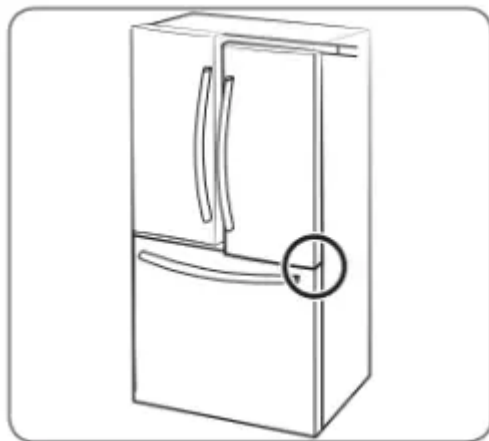

2. Insert a suitable-sized snap ring (A) between the door grommet (B) and the hinge as shown.

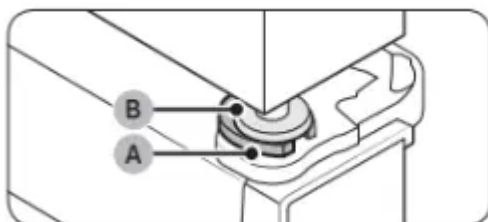

#### **CAUTION**

- Insert only one snap ring. If you insert two or more snap rings, the rings may slip out or make a rubbing noise.

- Keep the snap rings out of children's reach and keep them for future use.
- Do not raise the door too much. The door can contact and damage the top cover.

### **STEP 6 Attach the handles**



**CAUTION**

The refrigerator handles must be oriented in the correct direction.

- The fridge handles must be attached so that the holes on each face each other.
- The freezer handle must be attached so that its hole faces downwards.

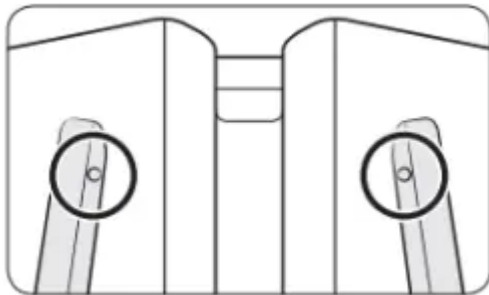

1. Using a Phillips screwdriver, attach the handle screws to the refrigerator, two for each handle respectively, as shown in the illustration to the left.

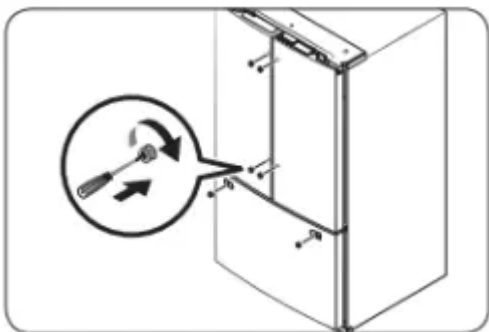

2. Attach the handle to the handle screws on the door.

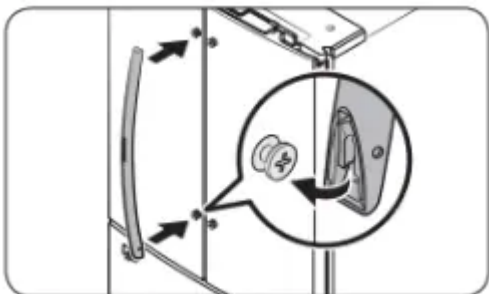

**For type B handle:** Insert the hook on the middle of the handle to its designated hole on the door, and then place the upper and lower part of the handles to the handle screws.

### **NOTE**

The design of the right side door handle may differ depending on your model.

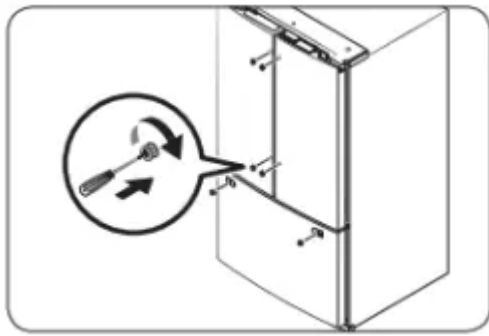

**3.** Push the handle down.

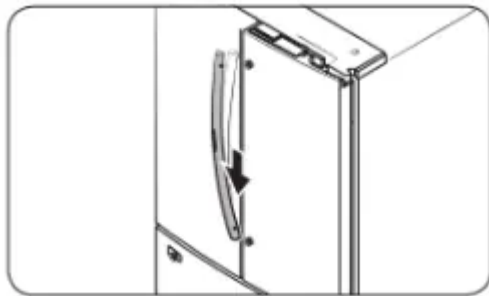

**4.** Insert an Allen wrench into the handle hole, and then turn it clockwise to tighten.

**5.** Repeat Steps 2 through 4 with the second refrigerator door handle.

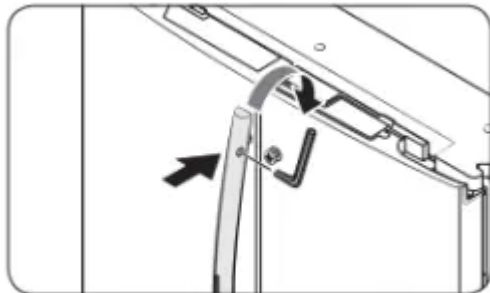

**6.** To attach the freezer handle to the refrigerator, first place the left side of the freezer handle onto the left handle screw, and then push it to the left.

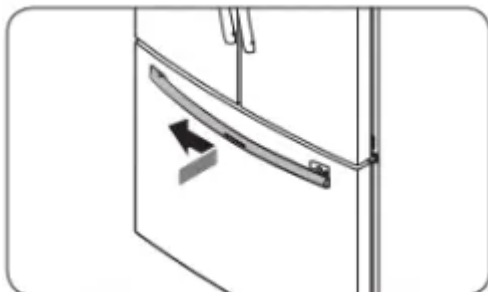

**7.** Then, place the right side of the freezer handle onto the right handle screw.

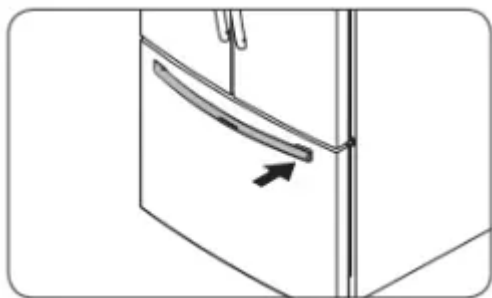

8. Insert an Allen wrench into the handle hole, and then turn it clockwise to tighten.

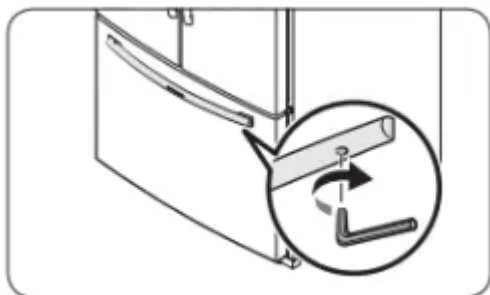

### **STEP 7 Connect the water dispenser line (applicable models only)**

A water dispenser with a filter is one of the helpful features on your new refrigerator. To help promote better health, the water filter removes unwanted particles from your water.

However, it does not sterilize or destroy microorganisms. You may need to purchase a water purifying system to do that.

The water line also connects to the ice maker. For the ice maker to operate properly, water pressure of 30 to 120 psi (206 to 827 kPa) psi is required.

If the refrigerator is installed in an area with low water pressure (below 30 psi / 206 kPa), you can install a booster pump to compensate for the low pressure.

After you have connected the water line, make sure the water storage tank inside the refrigerator is properly filled. To do this, press the water dispenser lever until water runs from the water outlet.

### **NOTE**

- Water line installation kits are available at extra cost from your retailer. We recommend using a water line installation kit that contains copper tubing and a 1/4" (6 mm) compression nut.

1. Shut off the main water source.
2. Insert the pipe clamp (B) and the shutoff valve (C) into the cold water line (A).

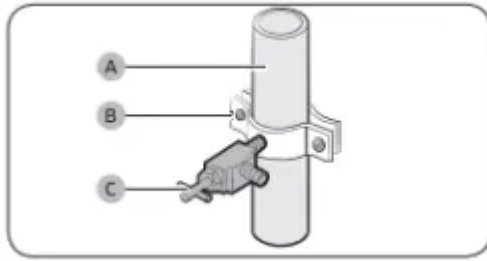

3. Connect the water line installation kit (A) to the shutoff valve (B).

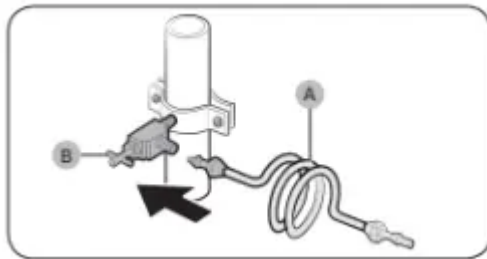

### Connect the water supply line to the refrigerator

There are several items you must purchase to complete this connection. You may find these items sold as a kit at your local hardware store.

Copper Tubing	<ul style="list-style-type: none"> <li>• 1/4" copper tubing</li> <li>• 1/4" compression nut (1 pc)</li> <li>• Ferrule (2 pc)</li> </ul>
Plastic Tubing	<ul style="list-style-type: none"> <li>• 1/4" plastic tubing → Molded end (Bulb)</li> <li>• 1/4" compression nut (1 pc)</li> </ul>

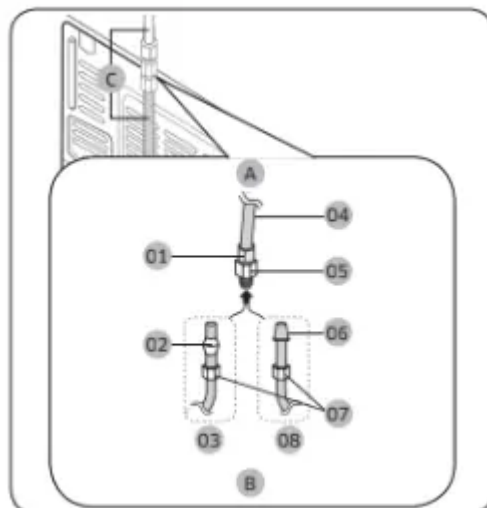

A. Refrigerator

B. Household water supply line

C. Water Line: must be kept straight.

1. Compression Nut (1/4") (Assembled)

2. Ferrule (Not supplied)

3. Copper tubing (Not supplied)
4. Plastic Tubing (Assembled)
5. Compression Fitting (Assembled)
6. Molded end (Bulb)
7. Compression nut (1/4") (Not supplied)
8. Plastic Tubing (Not supplied)

**NOTE**

If you have to relocate the refrigerator after connecting the **water line (C)**, make sure the joined section of the water line is straight.

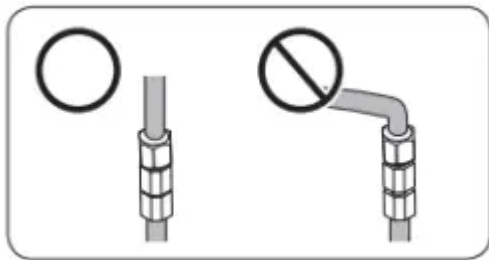

 **CAUTION**

Do not mount the water filter on any part of the refrigerator. This may damage the refrigerator.

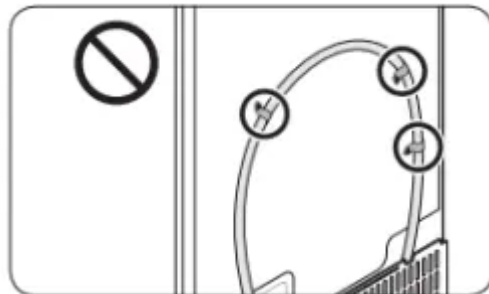

**1.** Connect the household water line to the assembled compression fitting.

- If you are using copper tubing, slip the compression nut (07) (not supplied) and ferrule (not supplied) on the copper tubing (not supplied) as shown.
- If you are using plastic tubing (08), insert the molded end (Bulb) of the plastic tubing into the compression fitting.

 **CAUTION**

- If you use plastic tubing (08), do not use it without the molded end (Bulb).

- Leaving the water line disconnected may cause the water valve to produce a buzzing sound over time. If this is the case, make sure that the ice making function is turned "OFF" and do not attempt to use the water dispenser.
2. Tighten the compression nut (07) onto the compression fitting. Do not over-tighten the compression nut (07).
  3. Turn the water on and check for any leakage. If you find water drops or leakage in the connection areas, turn off the main water supply. Check the connections and, if necessary, tighten.
  4. Flush 1 gallon of water through the filter before drinking or using the water from the refrigerator. (Flush approximately 6 minutes.) To flush, press a large glass or cup against the water dispenser lever. Fill the glass, empty it, and then repeat.
  5. After you turn on the refrigerator, let the ice maker make ice for 1 to 2 days. Over that period of time, throw out the first 1 or 2 buckets of ice the ice maker makes to ensure all impurities have been removed from the water line.

#### **NOTE**

Only connect the water line to a potable water source.

- If you have to repair or disassemble the water line, cut off 1/4" of the plastic tubing to make sure you get a snug, leak-free connection.
- You can test the water line quickly using a paper cup. Under normal conditions, the water dispenser can fill a 5 3/4 oz. (170 cc) cup in about 10 seconds.

#### **STEP 8 Initial settings**

By completing the following steps, the refrigerator should be fully functioning.

1. Plug the power cord into the wall socket to turn the refrigerator on.
2. Open the door, and check if the interior light lights up.
3. Set the temperature to the coldest setting, and wait for about an hour. Then, the freezer will be slightly chilled, and the motor should be running smoothly.
4. Wait until the refrigerator reaches the set temperature. Now the refrigerator is ready for use.

#### **STEP 9 Final check**

When installation is complete, confirm that:

- The refrigerator is plugged into an electrical outlet and grounded properly.
- The refrigerator is installed on a flat, level surface with a reasonable clearance from walls and cabinets.
- The refrigerator is level and is sitting firmly on the floor.

- The door opens and closes freely, and the interior light turns on automatically when you open the door.

## Operations

### Main panel

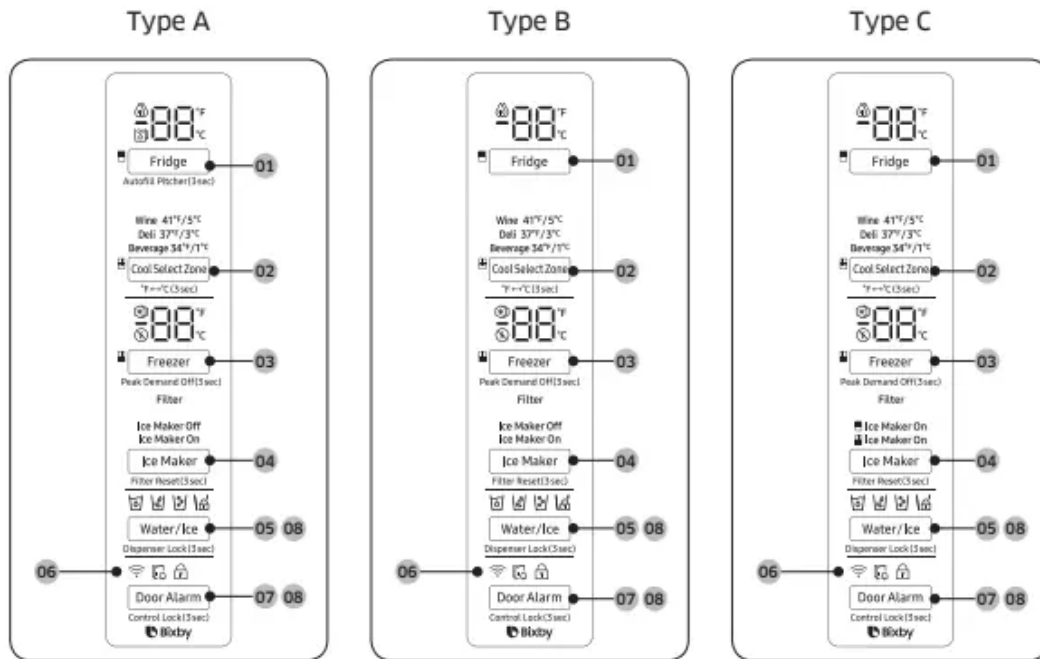

- |                                       |                                      |
|---------------------------------------|--------------------------------------|
| <b>01</b> Fridge / Autofill Pitcher * | <b>02</b> Cool Select Zone / °F ↔ °C |
| <b>03</b> Freezer / Peak Demand Off   | <b>04</b> Ice Maker / Filter Reset * |
| <b>05</b> Water/Ice / Dispenser Lock  | <b>06</b> Network connection         |
| <b>07</b> Door Alarm / Control Lock   | <b>08</b> Sabbath Mode               |
- \* applicable models only

### NOTE

- When you change the temperature on the panel, the panel displays the actual temperature inside the refrigerator until the temperature matches the temperature you set. Then, the panel displays the new set temperature. Note that it will take time for the refrigerator to reach the new temperature. This is normal. During this time, you do not need to set the temperature again.
- To ensure optimal performance, we recommend setting the temperature to 0 °F (-18 °C) for the freezer, and 37 °F (3 °C) for the fridge.
- The temperature in the refrigerator may rise if you open the door frequently or put a large amount of food into the refrigerator. If this happens, the temperature display blinks until the refrigerator returns to the specified temperature settings.

- If a communication error occurs between the temperature display and the main controller, this blinking continues for an extended time. Contact a local Samsung service center for technical assistance.
- The display of the main panel turns on only if the door is opened and turns off if the door is closed.
- If you set Control Lock on the main panel, the main panel locks automatically 1 minute after inactivity.
- Bixby is a Samsung's intelligence platform, and you can control the product with your voice. To use the voice command feature, you must connect the product with the
- SmartThings app on your phone. For products that do not recognize voice directly from the product, you can use the Bixby on your smartphone to control some of the functions of your product after connecting to the app.

## **01. Fridge / Autofill Pitcher (3 sec)**

### **Fridge**

You can use the Fridge button to set the fridge temperature or to activate Power Cool.

- Press Fridge repeatedly to select a desired temperature between 34 °F (1 °C) and 44 °F (7 °C).
- The temperature indicator displays the currently set or selected temperature.
  - To activate Power Cool, press Fridge repeatedly until the Power Cool indicator (🧊) lights up.
- To deactivate Power Cool, simply press Fridge again while the Power Cool function is on.
- Power Cool speeds up the cooling process at maximum power to lower the fridge temperature. The Power Cool process continues to run for several hours, and then turns off and the fridge returns to the previous temperature setting.
- Use Power Cool to rapidly cool food that spoils quickly or to rapidly cool the refrigerator after the door has been left open for some time.

### **NOTE**

Using Power Cool increases power consumption. Make sure you turn it off manually if you no longer need it, and then select the desired refrigerator temperature.

### **Autofill Pitcher**

Press and hold Fridge for 3 seconds to turn this function on. Open the left door of the fridge, and then insert the water pitcher. Close the door and the water pitcher will be filled with water up to the preset level.

To turn the function off, press and hold Fridge again for seconds.

## NOTE

- By default, Autofill Pitcher is disabled. Enable this function after you have installed the water line.
- If you open the door or push the dispenser lever, this function is stopped temporarily.
- The Autofill Pitcher indicators blink if there is a leak. This may occur because the water pitcher overflows, or the water-line or water-level sensor fails. If this is the case, follow these steps.

a. Open the rubber cap and drain water.

b. When draining is complete, the indicators stop blinking and turn solid.

c. Close the rubber cap.

- If the indicators continue to blink, this might be a system failure. Contact a local service center.

## 02. Cool Select Zone / °F ⇔ °C (3 sec)

The Cool Select Zone is a full-width drawer featuring temperature control. It has a temperature sensor that adjusts the amount of cold air allowed into the zone.

- Press Cool Select Zone repeatedly to select a desired mode. By default, Deli is selected.
- The refrigerator adjusts the temperature in the Cool Select Zone according to the selected mode.

Mode	Description	Examples
Wine	Select Wine to keep food fresh for a long time. The temperature of the Cool Select Zone will be kept around 41 °F (5 °C).	Wine, cocktails, cake, cheese
Deli	Select Deli to keep food fresh for a longer time. The temperature of the Cool Select Zone will be kept around 37 °F (3 °C).	Pineapples, lemons, biscuits, potatoes
Beverage	Select Beverage to keep drinks cold and refreshing. The temperature of the Cool Select Zone will be kept around 34 °F (1 °C).	Bottled water, juice, soft drinks, beer



## CAUTION

- Do not use the Cool Select Zone to store most kinds of fruit or leafy vegetables. These food items may suffer cold-temperature damage.
- Do not store glass bottles in the Cool Select Zone in Beverage mode. They may break and cause physical injury.

°F ↔ °C	<p>You can also use the <b>Cool Select Zone</b> button to switch the temperature scale between Celsius and Fahrenheit.</p> <p>To switch the temperature scale, press and hold <b>Cool Select Zone</b> for 3 seconds to change the current temperature scale.</p>
---------	--

### 03. Freezer / Peak Demand Off (3 sec)

#### Freezer

You can use the Freezer button to set the freezer temperature or to activate Power Freeze.

- Press Freezer repeatedly to select a desired temperature between 5 °F (-15 °C) and -8 °F (-23 °C).
- The temperature indicator displays the currently set or selected temperature.
  - To activate Power Freeze, press Freezer repeatedly until the Power Freeze indicator (❄️) lights up.
- To deactivate Power Freeze, simply press Freezer again while the Power Freeze function is on.
- Power Freeze speeds up the freezing process at maximum power to lower the freezer temperature. The Power Freeze process continues to run for several hours, and then turns off and the freezer returns to the previous temperature setting.
- To freeze large amounts of food, activate Power Freeze for at least 20 hours before putting the food in the freezer.

#### NOTE

Using Power Freeze increases power consumption. Make sure you turn it off manually if you no longer need it, and then select the desired freezer temperature.

#### Peak Demand Off

The Peak Demand Off function activates/deactivates Smart Grid. (See Page 51)  
Press Freezer for 3 seconds to set/clear the Peak Demand Off function.

### 04. Ice Maker / Filter Reset (3 sec)

#### Ice Maker

Press Ice Maker to turn the ice maker on or off.

The ice maker has 2 indicators (**Ice Maker On / Ice Maker Off**) to indicate its operating status.

- When the ice maker operates, the corresponding indicator (**Ice Maker On**) turns on.
- When the ice maker is turned off, the corresponding indicator (**Ice Maker Off**) turns on. In this case, ice making is disabled even if you press the Cubed or Crushed Ice buttons on the dispenser panel. To enable ice making, you must turn the ice maker on.

## NOTE

If the fridge part ice maker is turned off, it will turn on if you press and hold the ice lever for more than 5 seconds.

### **Twin Ice-Maker models only**

#### **Ice Maker On**

- When the fridge part ice maker operates, the corresponding indicator (**Ice Maker On**) turns on.
- When the fridge part ice maker is turned off, the corresponding indicator (**Ice Maker On**) turns off.

#### **Ice Maker On**

- When the freezer part ice maker operates, the corresponding indicator (**Ice Maker On**) turns on.
- When the freezer part ice maker is turned off, the corresponding indicator (**Ice Maker On**) turns off.

#### **Filter Reset**

After about 6 months (and typically, about 300 gallons (1200L) of water), the Filter indicator blinks red for several seconds when you open the door, reminding you that the filter needs to be replaced.

When this happens, replace the filter, and then press and hold Ice Maker for 3 seconds. The filter lifecycle will be reset and the Filter indicator turns off.

## NOTE

- Some regions have relatively large amounts of lime in their water. This can reduce the lifecycle of the filter. In these areas, you will have to replace the water filter more often than specified above.
- If water is not dispensing properly, the water filter is most likely clogged. Replace the water filter.

### **05. Water/Ice / Dispenser Lock (3 sec)**

#### **Water/Ice**

You can dispense chilled water, cubed ice, or crushed ice. To dispense, press Water/Ice. The corresponding indicator turns on.

#### **Dispenser Lock**

(Dispenser panel / Dispenser lever)

To prevent use of the dispenser panel buttons and the dispenser lever, press and hold Water/Ice for more than 3 seconds.

If you press and hold the button again for more than 3 seconds, the dispenser lock will be deactivated.

## NOTE

- The Dispenser Lock on the dispenser panel does not affect the controls on the main panel. To lock the main panel, use the Control Lock function on the main panel.
- If you press Water/Ice for 3 seconds when both control lock and dispenser lock are active, you will deactivate both control lock and dispenser lock.

## 06. Network connection

You can control and monitor your refrigerator on the SmartThings app. For more information, see the SmartThings section.

## 07. Door Alarm / Control Lock (3 sec)

### Door Alarm

If the door is left open for more than 2 minutes, an alarm will sound and the alarm indicator will blink. You can toggle the alarm on and off by pressing Door Alarm. The alarm is enabled by factory default.

If the door is left open for 5 minutes, internal lights (in the fridge and freezer) will blink for 10 seconds and then turn on. The whole process will be repeated every minute for 5 minutes. This is to alert hearing-impaired users that a door is open. Note that this function is normal.

### Control Lock

To prevent accidental setting changes, press and hold Door Alarm for 3 seconds. The main panel will be disabled and the Lock indicator (🔒) will turn on.

When Control Lock is on, the indicator blinks if any button on the main panel is pressed.

If you press and hold the button again for more than 3 seconds, Control Lock will be deactivated.

However, Control Lock will be reactivated if no button is pressed within 1 minute.

## NOTE

Control Lock on the main panel does not affect the dispenser. The dispenser operates independently and so does the dispenser lever. To lock the dispenser and the dispenser lever, use the Dispenser Lock function.

## 08. Sabbath Mode

The Sabbath mode stays active for 85 hours once it is activated. After that, it will be deactivated automatically.

- To activate Sabbath Mode, press and hold Door Alarm and Water/Ice simultaneously for 5 seconds. When the refrigerator is in Sabbath mode, the buttons, the display, and the internal lights do not function. The refrigerator and freezer, however, continue to cool.
- To deactivate Sabbath Mode, press and hold Door Alarm and Water/Ice simultaneously again for 5 seconds.

## NOTE

- If the refrigerator powers off and restarts (for example, if there is a power failure), the Sabbath mode remains active. To end Sabbath Mode, you must deactivate it as described above.
- Controls must be unlocked before activating Sabbath mode.

## 09. Cooling Off

Cooling Off mode (also called Shop mode) is designed for use by retailers when they are displaying refrigerators on a retail floor.

In Cooling Off mode, the refrigerator's fan motor and lights operate normally, but the compressors do not run so neither the refrigerator nor the freezer become cold.

To enter or exit the Cooling Off mode, press and hold Fridge and Cool Select Zone simultaneously for 6 seconds. Then, when the display blinks, press Door Alarm.

When the Cooling Off mode is on, the refrigerator chime sounds, and the refrigerator shows "0" on the fridge temperature display and "FF" on the freezer temperature display.

## SmartThings

### Installation

Visit the Google Play Store, Galaxy Apps, or Apple App Store and search for "SmartThings". Download and install the SmartThings app provided by Samsung Electronics to your smart device.

## NOTE

- The SmartThings app is designed for Android 6.0 (Marshmallow) or later, iOS 10.0 or later, iPhone 6 or later, and is optimized for Samsung smartphones (Galaxy S and Galaxy Note series).
- For improved performance, the SmartThings app is subject to change without notice or discontinued support according to the manufacturer's policy.
- Recommended encryption systems include WPA/TKIP and WPA2/AES. Any newer or non-standard Wi-Fi authentication protocols are not supported.
- Wireless networks may be affected by the surrounding wireless communication environment.
- If your Internet service provider has registered the MAC address of your PC or modem for identification, your Samsung Smart Refrigerator may fail to connect to the Internet.
- If this happens, contact your Internet service provider for technical assistance.
- The firewall settings of your network system may prevent your Samsung Smart

- Refrigerator from accessing the Internet. Contact your Internet service provider for technical assistance. If this symptom continues, contact a local Samsung service center or retailer.
- To configure the wireless access point (AP) settings, see the user manual of the AP router).
- Samsung Smart Refrigerators support both Wi-Fi 2.4 GHz with IEEE 802.11 b/g/n and Soft-AP protocols. (IEEE 802.11 n is recommended.)
- Unauthorized Wi-Fi wireless routers may fail to connect to applicable Samsung Smart Refrigerators.

### **Samsung account**

You are required to register your Samsung account to use the app. If you don't have a Samsung account, follow the app's onscreen instructions to create a free Samsung account.

### **Getting started**

Turn on the device you want to connect, open the SmartThings app on your phone, and then follow the instructions below.

If a pop-up appears saying that a new device has been found, tap ADD NOW.

If a pop-up doesn't appear, tap the + button, and then select the device you want to connect from the list of available devices.

If your device isn't in the list of available devices, tap Supported Devices, select the device type (Refrigerator), and then select the specific device model.

Follow the instructions in the app to set up your device. Once setup is complete, your refrigerator will appear as a "card" on your Devices screen.

### **Refrigerator app**

#### **Integrated control**

You can monitor and control your refrigerator at home and on the go.

- Tap the refrigerator icon on the SmartThings Dashboard or tap the Devices icon at the bottom of the Dashboard, and then tap the refrigerator "card" to open the Refrigerator page.
- Check the operation status or notifications related to your refrigerator, and then change options or settings if necessary.

### **NOTE**

Some options or settings of the refrigerator may not be available for remote control.

### **Monitoring**

#### **Item: Fridge temperature**

- Description: Displays the desired temperature setting of the fridge.

**Item: Freezer temperature**

- Description: Displays the current temperature of the freezer.

**Item: Cool Select**

- Description: Zone settings Displays the settings of the Cool Select Zone.

**Item: Diagnosis**

- Description: Detects abnormal operations of the refrigerator.

**Item: Energy monitoring**

- Description: Checks the accumulated power consumption of the refrigerator for the last 180 days.

**Functions****Item: Ice making**

- Description: You can turn the ice making function on or off, and check the current settings of the function.
- You can also check the status and progress of ice making.

**Item: Power Cool**

- Description: You can turn Power Cool on or off, and check the current settings.

**Item: Power Freeze**

- Description: You can turn Power Freeze on or off, and check the current settings.

**Item: Fridge temperature**

- Description: You can set the desired temperature of the fridge.

**Item: Freezer temperature**

- Description: You can set the desired temperature of the freezer.

**Item: Cool Select**

- Description: Zone settings You can set the desired Cool Select Zone mode.

**Item: Sabbath Mode**

- Description: You can activate and deactivate the Sabbath mode.

**Alarms****Item: Abnormally high temperature**

- Description: This alarm is triggered when the fridge or the freezer has abnormally high temperatures.

**Item: Door opening**

- Description: This alarm is triggered if the fridge door or the freezer drawer is open for a specific time.

**Item: Autofill Pitcher overflowing**

- Description: If the Autofill Pitcher function senses an overflow, it triggers this alarm to let you know the status of the overflow.

**Item: Water filter replacement**

- Description: This alarm reminds you that the water filter must be replaced.

**SMART GRID Function (Demand Response)**

When the refrigerator operates in SMART GRID (Demand Response) mode, the Energy Management Refrigerator function can control energy usage or delay the operation of some functions to save money when energy prices or demand are the highest.

**NOTE**

- You can deactivate the SMART GRID (Demand Response) function at any time using the Peak Demand Off function.
- To use the SMART GRID (Demand Response) function, you need a separate contract with your electric utility company.

In addition, to use the Smart Grid (Demand Response) function, you must register for the service with your electric company. The company must have an EMS (Energy Management System) that supports SEP (Smart Energy profile).

**Using the SMART GRID (Demand Response) Function**

This feature monitors energy prices and demand information from your utility company and sends notifications to the refrigerator to run high energy consuming tasks during off-peak times when electricity costs and demand are lower. If the refrigerator receives a control signal from the utility company, the refrigerator will display the DAL (L3) ~ TALR (L4) levels on the refrigerator display and control the power consumption according to the level.

[Exception condition] The DAL and TALR control signals from a utility company work as long as product performance is maintained. If the refrigerator receives the SMART GRID (Demand Response) signal (DAL or TALR), the refrigerator will operate in Delay Appliance Load (Display:L3) or Temporary Appliance Load Reduction (Display:L4) mode.

- Delay Appliance Load (L3): The refrigerator responds to a DAL signal by providing a moderate load reduction for the duration of the delay period. This function controls functions that consume a lot of energy such as adjusting the Cooling system, running the defrost cycle, and making ice.

- When the refrigerator operates in DAL (L3) mode, "L3" is displayed on the refrigerator display.
- **DAL** mode is automatically deactivated after it lasts for the amount of time stipulated by the DAL signal (max. 4.5 hours) or when the Peak Demand Off key is pressed.
  - Temporary Appliance Load Reduction (L4): The refrigerator responds to a TALR signal by aggressively reducing the load for a short time period. This function reduces energy consumption by stopping the compressor and controlling the functions that consume a lot of energy such as the defrost cycle and making ice.
- When the refrigerator operates in TALR (L4) mode, "L4" is displayed on the refrigerator display.
- TALR (L4) mode is automatically deactivated after it lasts for the received duration max. 15 minutes), or when the Peak Demand Off key is pressed. The mode is immediately deactivated and the refrigerator returns to the normal state when the door is opened or closed, or the dispenser is used.

**To check the MAC address**

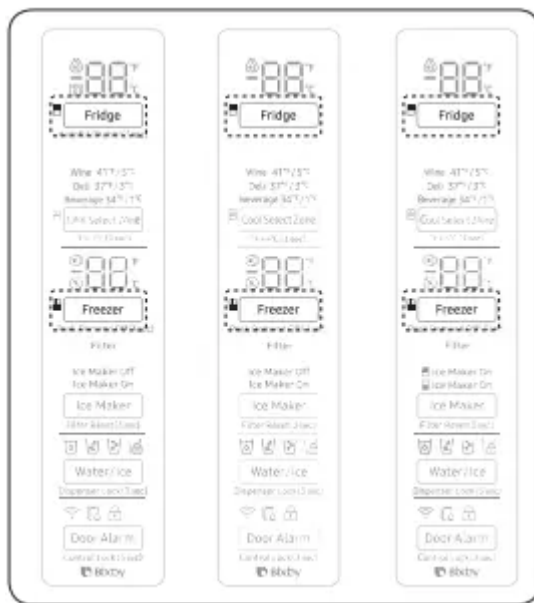

1. In this mode, the MAC address appears on the temperature panel (on both the freezer and the fridge sections of the panel) sequentially for 1 minute. Press and hold both Freezer and Fridge for 6 seconds. The temperature panel blinks. Then, press Freezer again to display the MAC address. The fridge beeps.
2. For example, if the MAC address is the temperature panel displays the address for 1 minute in this sequence: "-- / --" "11 / 22" After the 1 minute, the MAC address disappears and the temperature panel returns to the normal state.

**NOTE**

The temperature panel displays "-- / --" for an unknown MAC address or if a Wi-Fi connection is not established or is lost.



## **Peak Demand Off (Override mode)**

When you want the refrigerator to ignore the SMART GRID (Demand Response) signal from the utility company, you can activate Peak Demand Off (Override mode).

When you activate Peak Demand Off (Override mode), the refrigerator ignores the SMART GRID (Demand Response) signal and is not controlled by the utility company.

### **Activating and deactivating Peak Demand Off (Override mode)**

1. Press and hold Freezer for 3 seconds.
2. A buzzer sounds and 'Or' and 'on' is displayed in the freezer and fridge temperature displays for 5 seconds. Then the Peak Demand Off (Override mode) icon turns on.
3. If the refrigerator receives a SMART GRID (Demand Response) signal from the utility company, 'Or' is displayed in the freezer temperature display.
4. To deactivate Peak Demand Off (Override mode), press and hold Freezer for 3 seconds.
5. A buzzer sounds and 'Or' and 'oF' is displayed in the freezer and fridge temperature displays for 5 seconds. Then the Peak Demand Off (Override mode) icon turns off.

#### **NOTE**

- Alternatively, you can activate or deactivate Peak Demand Off (Override mode) using the SmartThings app and the Energy Management function. See the next page.

### **Using the Energy Management Function**

The Energy Management function enables you to control and monitor your Energy Management refrigerator using the SmartThings app for your convenience.

#### **NOTE**

- To use the Energy Management refrigerator functions, you have to install the corresponding app first.

#### **1. Operational Status**

- You can check the DR and Peak Demand Off (Override mode) status.

#### **2. Energy Consumption Reporting**

- Shows the accumulated power consumption. Power consumption data is updated every 10 minutes.

#### **NOTE**

The energy consumption report may differ from the power consumption specifications of the product depending on the operating environment and the stored food.

### 3. Delay Defrost Capability

- The Delay Defrost Capability function saves energy by delaying the defrost operation to a time specified by the user. You can configure the time, and this function will save energy during the specified period in a 24 hour cycle. If the time is not set, the function works with the default time settings. The default time settings are below:
- 6 am to 10 am: 1st. November ~ 30th. April
- 3 pm to 7 pm: 1st. May ~ 31th. October

#### To change the time setting for the Delay Defrost Capability

You can change the time setting for the Delay Defrost Capability on the app.

#### Dispenser panel

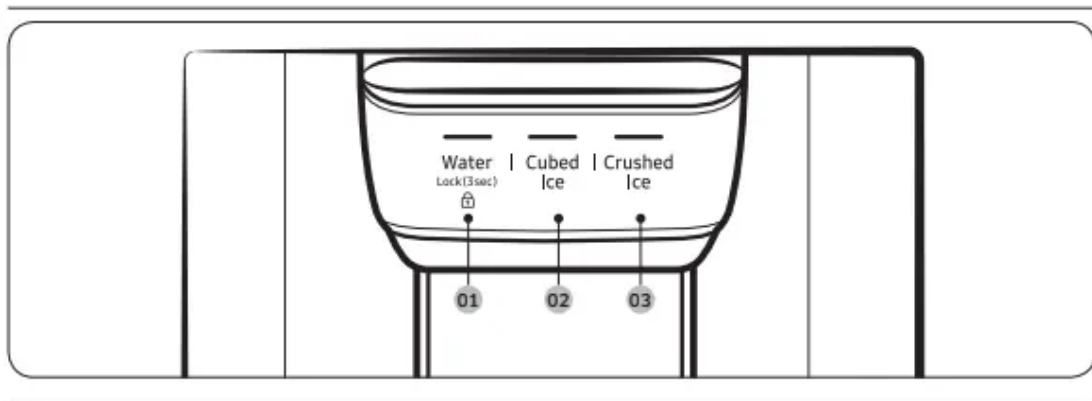

01 Water / Lock

02 Cubed Ice

03 Crushed Ice

#### 01. Water / Lock (3 sec)

##### Water

To dispense chilled water, press Water. The corresponding indicator turns on.

##### Lock

(Dispenser panel / Dispenser lever)

To prevent the use of the dispenser panel buttons and the dispenser lever, press and hold Water for more than 3 seconds. If you press and hold the button again for more than 3 seconds, the dispenser lock will be deactivated. When dispenser lock is on, the indicator blinks if any button on the dispenser panel is pressed or the dispenser lever is pressed.

##### NOTE

The Lock on the dispenser panel does not affect the controls on the main panel. To lock the main panel, use the Control Lock function on the main panel.

## 02. Cubed Ice

### Cubed Ice

Press Cubed Ice to dispense cubed ice. The corresponding indicator turns on.

## 03. Crushed Ice

### Crushed Ice

Press Crushed Ice to dispense crushed ice. The corresponding indicator turns on.

## Special features

### Water pitcher (Autofill Pitcher) (applicable models only)

The Autofill Pitcher function lets you enjoy cold brewed tea in your refrigerator.

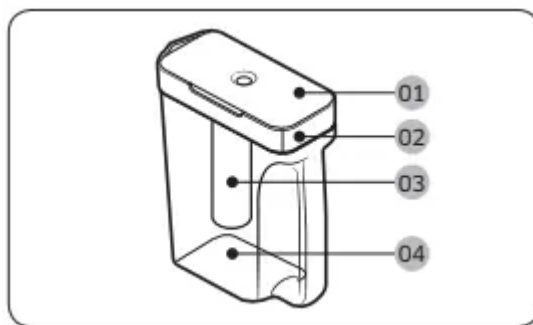

1. Lid
2. Sealed mouth
3. Infuser
4. Body

### To fill the Water pitcher

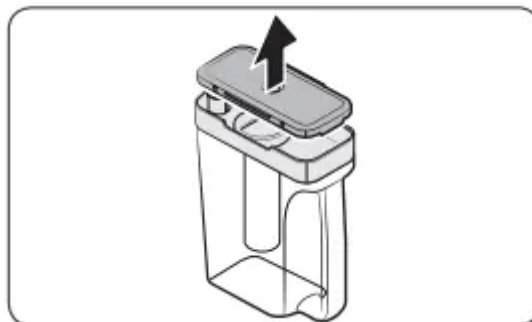

1. Grasp a handle groove of the sealed mouth, and then pull up to open the lid.
2. Put tea leaves or fruit to your taste into the infuser.

### **NOTE**

If you want to keep the infused water in its initial concentration, turn the Autofill Pitcher function off.

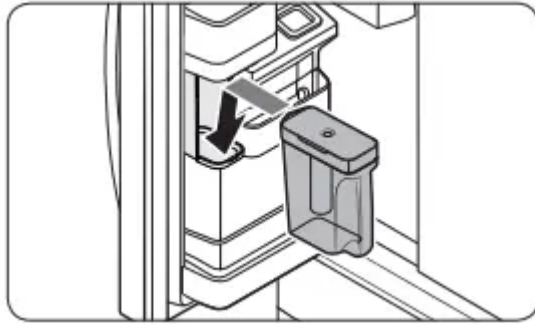

3. Enable the Autofill Pitcher function on the main panel. Open the left door of the fridge door, and then mount the water pitcher onto the holder. Push it straight in as shown in the illustration on the left.

4. Close the door. The water pitcher will start to fill with chilled water a short time later.

 **CAUTION**

Make sure the water pitcher fits in the water pitcher holder.

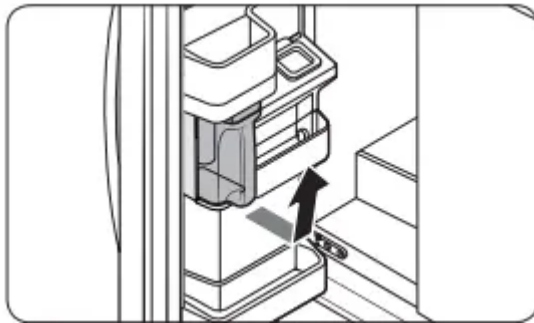

5. To drink tea, open the door and detach the water pitcher. Pull it straight out.

 **CAUTION**

- We recommend consuming fruit infused water within 24 hours. After that, the infused water can spoil over time.
- You must clean the water pitcher after you have consumed the infused water. Also clean the water pitcher if you haven't used it for a long time.

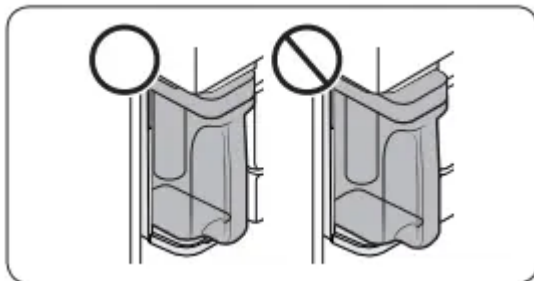

- To prevent the water pitcher from tipping over or leaking, make sure the water pitcher fits in the water pitcher holder.

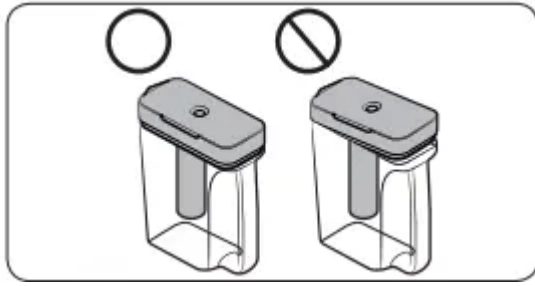

- To prevent the water pitcher from spilling over or leaking, make sure the sealed mouth is properly inserted.

**NOTE**

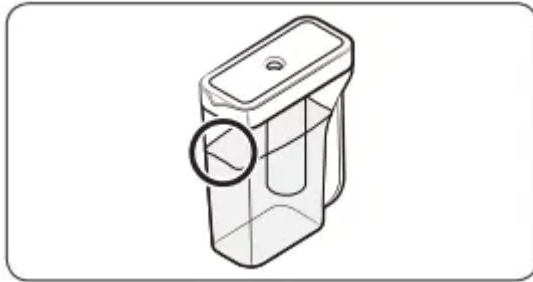

- If the front side (specifically marked area) of the water pitcher has too much moisture, the water pitcher may not fully fill. Remove the moisture, and then try again.
- Autofill Pitcher function will stop supplying water to the water pitcher if the water pitcher does not fill after a certain amount of time. If this happens, check if the water line is properly connected. Remove and reinsert the water pitcher, and then try again.

**NOTE**

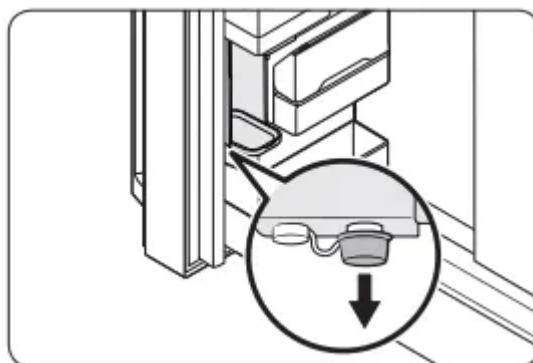

- Wipe around the infuser holder if the infuser overflows or leaks.
- Water drops off if the rubber cap is opened.
- The Autofill Pitcher indicator blinks if there is a leak. In case of a leak, open the rubber cap so that the leaked water drains. The indicator will then turn off.
- However, if the indicator continues to blink, there might be a system failure.

- Contact your local Samsung service center.
- The Autofill Pitcher indicators blink if there is a leak. See page 40 for more information.

### **Water/Ice dispenser**

Using the dispenser, you can dispense water with or without ice. The water dispenser offers 3 options: chilled water, cubed ice, and crushed ice. To dispense chilled water, press Water on the dispenser panel. Put a water glass under the dispenser, and then push the dispenser lever.

To dispense water with ice

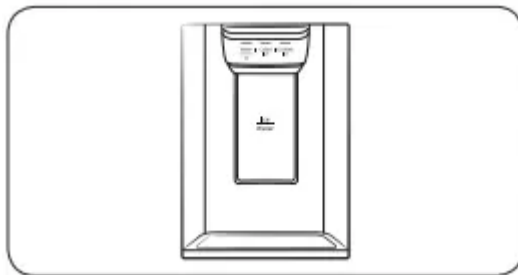

1. With the Ice Maker enabled, press Cubed
2. Ice or Crushed Ice to select the ice type.
3. Put a water glass under the dispenser, and then push the dispenser lever with the glass. Ice will be dispensed from the dispenser.
4. Press Water to select water.
5. Push the dispenser lever with the glass. Water will be dispensed from the dispenser.

### **NOTE**

- The dispenser will stop dispensing if you keep pushing the dispenser lever for about 1 minute. To dispense more water, release and push the lever again.
- Make sure the glass is in line with the dispenser to prevent the dispensed water from spilling out.
- If you do not use the water dispenser for 2-3 days, the dispensed water may have an abnormal smell or taste. This is not a system failure. Discard the first 1-2 glasses of water.

### **Ice maker**

The refrigerator has a built-in ice maker that automatically dispenses ice so that you can enjoy filtered water with cubed or crushed ice.

### **Ice making**

After you have installed your refrigerator and plugged it in, follow these instructions to ensure proper ice making and to keep the ice bucket full of ice:

1. Let the refrigerator operate for at least 24 hours to ensure optimal performance.
2. Dispense the first 4 to 6 ice cubes into a glass.
3. Wait another 8 hours and dispense another 4 to 6 ice cubes.
4. Then, wait another 16 hours and dispense the first glass-full of ice.

#### NOTE

- If you consume all the ice at once, you must wait 8 hours before dispensing the first 4 to 6 cubes. This ensures that the ice bucket is filled with ice properly.
- Ice cubes generated rapidly may look white, which is normal.

#### Diagnosis

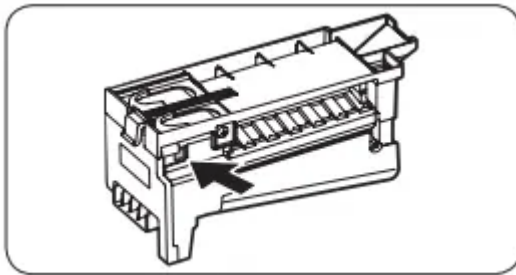

If ice does not dispense, first check the ice maker.

1. Press Test on the side of the ice maker. You will hear a chime (ding-dong) when you press the button.
2. You will hear another chime if the ice maker is operating properly.

#### CAUTION

- If the ice making chime rings repeatedly, contact your waterline installer or a local Samsung service center.
- Do not press Test repeatedly after the ice tray is filled with ice or water. Water may overflow or ice may jam.
- Do not put food in the ice bucket. The frozen food may damage the ice maker, especially when you open or close the door.
- When the refrigerator recovers power after a power failure, the ice bucket may contain a mix of melted and jammed ice cubes, which can prevent the ice maker from working properly. To prevent this, make sure to empty the ice bucket so the ice bucket can refill with fresh, loose ice cubes.
- Do not put fingers or any objects into the dispenser outlet or the ice maker. This can cause physical injury or property damage.

- When reinserting the ice maker tray, make sure that the tray is properly centered at the entrance. Otherwise, the tray can get stuck.

#### If You Turn the Ice Maker Off

If you press and hold Ice Maker for more than 3 seconds to turn the ice maker off, make sure to remove all ice cubes from the ice bucket. Remaining ice cubes may clump together, making it difficult to remove them. To remove the ice bucket, see the Ice bucket (applicable models only) section on page 45.

#### NOTE

- Removal of the ice bucket does not affect the thermal and mechanical performance of the refrigerator.

#### Water clouding

Water supplied to the refrigerator flows through a core alkaline filter. During this filtering process, the water pressure of the water increases and the water becomes saturated with oxygen and nitrogen. This causes the water to look misty or cloudy temporarily when dispensed. This is normal and the water will look clear after a few seconds.

#### Cool Select Zone (applicable models only)

The Cool Select Zone is a full-width drawer with adjustable temperature control. The Cool Select Zone can be used for large party trays, deli items, pizza, beverages, or miscellaneous items.

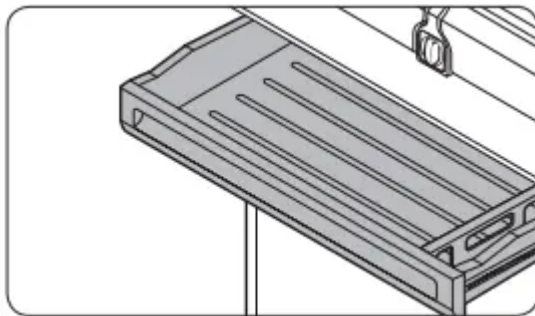

#### CAUTION

- Do not use the Cool Select Zone to store most kinds of fruit or leafy vegetables. These food items may suffer cold-temperature damage.
- Do not store glass bottles in the Cool Select Zone in Beverage mode. They may break and cause physical injury.

# Maintenance

## Handling and care

### Ice bucket (applicable models only)

If you do not dispense ice for an extended period, ice may form clumps inside the bucket. If this happens, remove and empty the ice bucket.

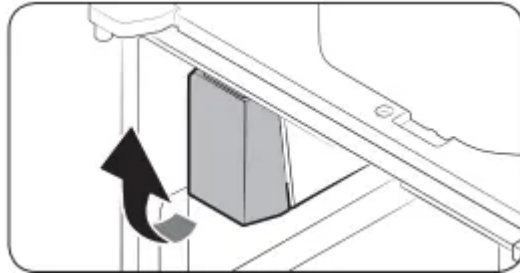

1. To remove the ice bucket, gently lift it up, and then pull it out slowly while holding the bottom of the bucket with one hand and the side with the other hand.

2. Empty the bucket.

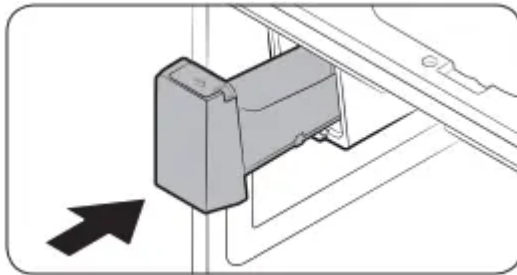

3. When done, put the bucket back into position. If the bucket does not fit in, turn the helix screw 90 degrees, and then try again.

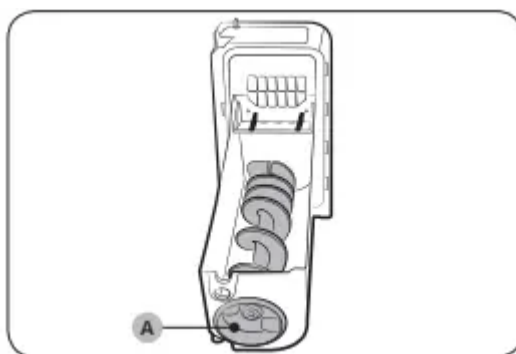

If the ice bucket is not firmly inserted, turn the Helix (A) 90 degrees, and then try again.

### CAUTION

- Do not apply excessive force to the bucket cover. The cover may break.
- Do not forcefully close the door. Water may spill over the ice maker.

- To prevent injury, make sure to clean up any ice or water that has fallen on the floor.
- To prevent accidents or injury, do not let children play with the water dispenser or the
- ice maker.
- Do not put your hand or an object into the ice chute. This may cause physical injury or product damage.
- Use only the provided ice bucket. Third-party ice buckets may cause a system failure.

#### NOTE

- The water pressure required for ice making is between 30 to 120 psi (206 to 827 kPa).
- Noise from the ice maker as it produces ice during the ice making process is normal.
- While the door is open, neither the ice maker nor the water dispenser operates.

#### Autofill pitcher (applicable models only)

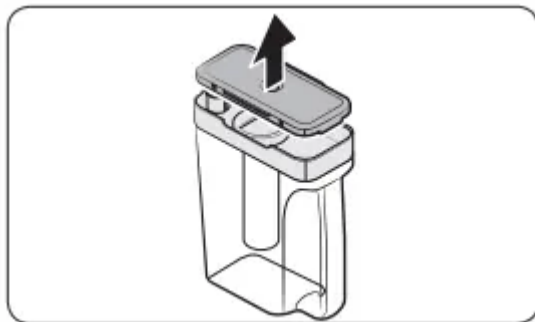

1. Grasp a handle groove of the sealed mouth, and then pull up to remove.

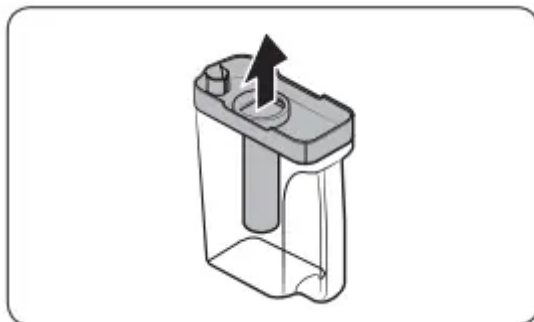

2. Grasp both sides of the sealed mouth, and then lift to remove.

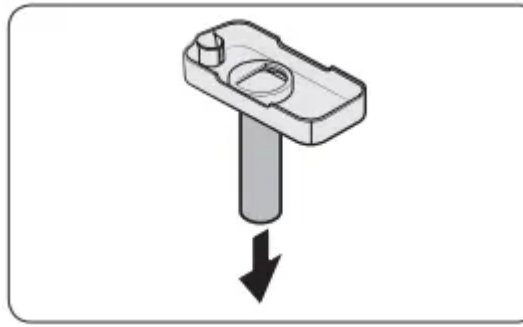

3. While slightly twisting the infuser, pull it out of the sealed mouth.
4. Clean the infuser with neutral agents and running water. Rinse and dry well.
5. Reassemble the Autofill pitcher in the reverse order of disassembly.

 **CAUTION**

Water pitcher and lid are not dishwasher safe and can deform under high temperatures. Please hand wash as needed.

### **Fridge shelves**

The appearance of the shelves differs by model.

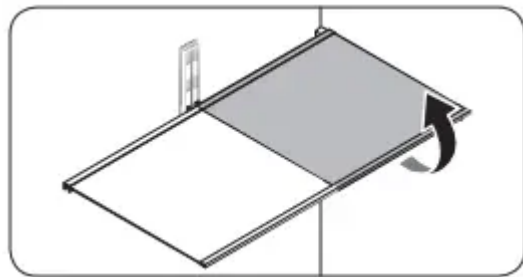

To remove a shelf, fully open the corresponding door. Hold the front of the shelf, and then gently lift up and slide out.

**NOTE**

Do not lift up the shelf fully when removing or reinserting the shelf. The rear wall of the fridge room can be dented.

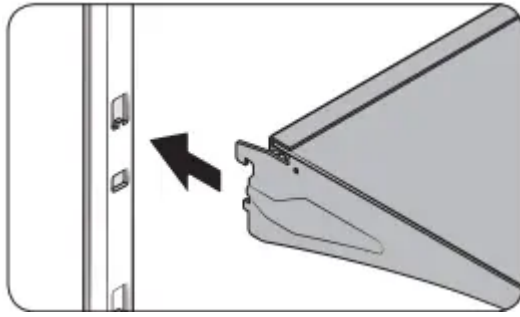

- To reinsert, hold the shelf at an angle so the front is higher than the back, and then insert the top hook into the top shelf notch. Then, lower the shelf and insert the bottom shelf hook into the bottom shelf notch.

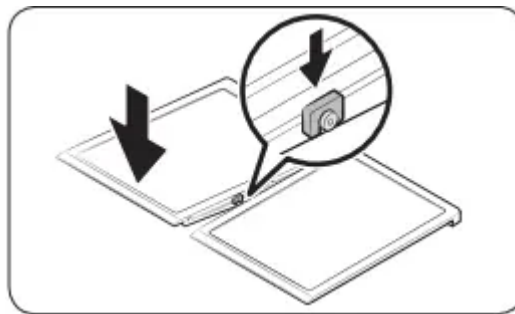

**⚠ CAUTION**

- The tempered glass shelves are heavy.
- Use caution when removing them.
- The shelf must be inserted correctly. Do not insert upside down.
- Glass containers may scratch the surface of glass shelves.
- You must insert the right-side shelf first, and then insert the left-side shelf.
- If you do not follow this order, locking mechanisms on the shelf cannot properly locked.

**Foldable shelf**

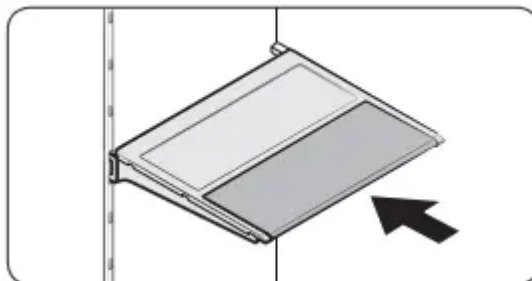

To remove, slide up the front of the shelf so that it folds. Then gently lift up and pull out. To reinsert, place the shelf on the angled frame in the main unit, and then, press down to unfold.

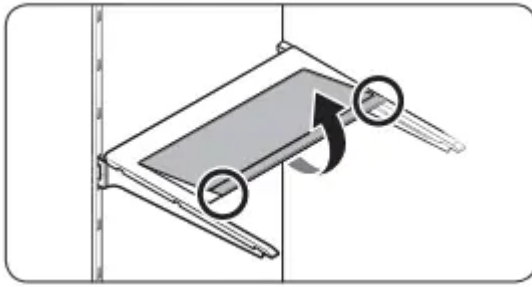

**⚠ CAUTION**

After sliding the foldable shelf in and folding it, the front of the shelf can be removed for your convenience. If you use the shelf without removing the front of the shelf, be aware that it can separate from the rear portion. Take care when handling food items near the shelf.

Recommended foldable shelf location

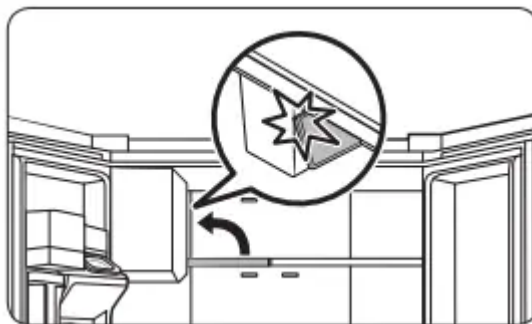

The foldable shelf folds up from the center, giving you more room for storage.

- Insert the shelf in the right side of the fridge. Left side insertion does not allow the shelf to fold completely.
- To fold, push the front area of the shelf inward so that it folds up from the middle.

**⚠ CAUTION**

Do not lift up quickly or twist the foldable shelf to take out food under it. It may fall off.

Vegetable shelf

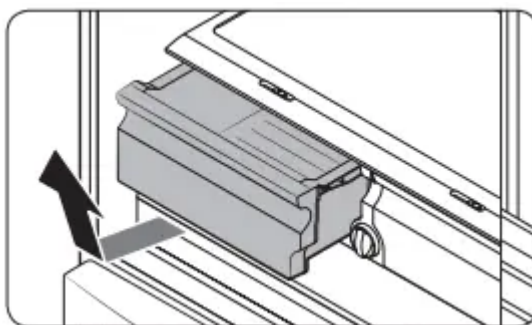

1. Slide out the left-side vegetable drawer.

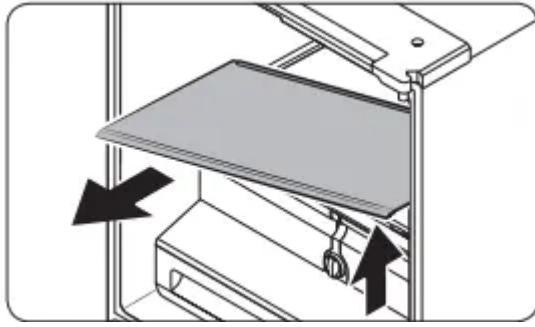

2. While supporting the vegetable shelf with one hand, slide it out with the other hand.

#### **NOTE**

To use the space that is opened up after removing the glass shelf, take out the vegetable shelf.

To reinsert, follow the steps above in the reverse order.

#### **Door bins**

- To remove the door bin, hold the front sides of the bin, and then gently lift up to remove.
- To reinsert, insert the door bin slightly above its final location making sure that the back of the bin is against the door. Hold the rear of the door bin with both hands, and then press down so that it fits snugly.

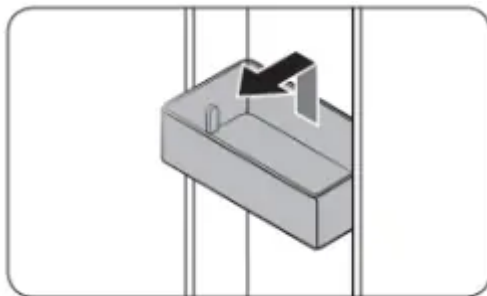

#### **CAUTION**

- Do not remove a bin that is filled with food. Empty the bin beforehand.
- Use caution when opening the door if the bottom bin contains larger bottles, which may fall over.
- Do not allow children to play with the bins. Sharp corners of the bin may cause injury.

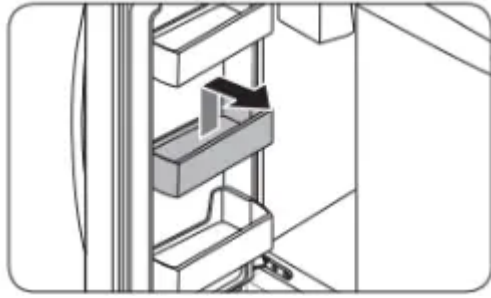

## Fridge drawers

Vegetable / fruit drawers

Gently lift up the front of the drawer and slide out.

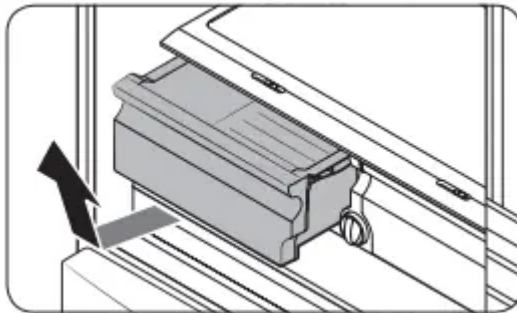

- We recommend that you remove the door bins before removing the drawer. This is to prevent damage to the door bins.
- To reinsert, insert the drawer into the frame rails and then slide inward.

## Cool Select Zone

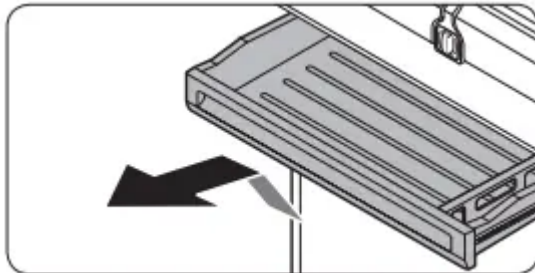

- To remove, fully open the Cool Select Zone. Then, slightly lift the front side and pull straight out.
- To reinsert, push the rails to the back of the refrigerator. Then, place the Cool Select Zone drawer onto the rails and slide it back until it is in place.

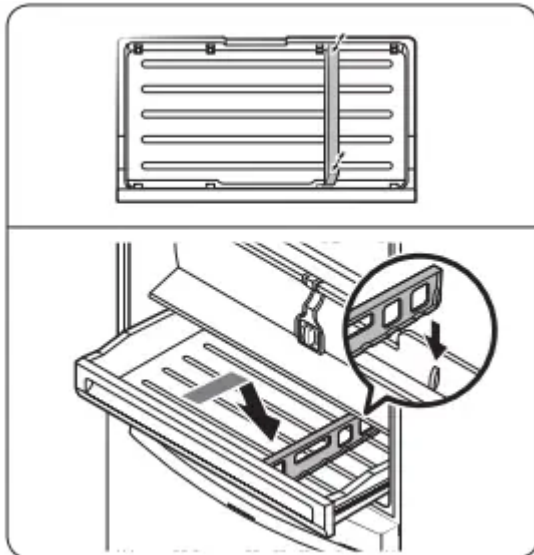

- To remove the divider, lift the front side of the divider to unhook it from the wall, and then pull the divider out.
- To reinsert the divider, hook the back of the divider over the rear wall, and then push the divider down.

### Freezer baskets

Lower ice bucket (applicable models only)

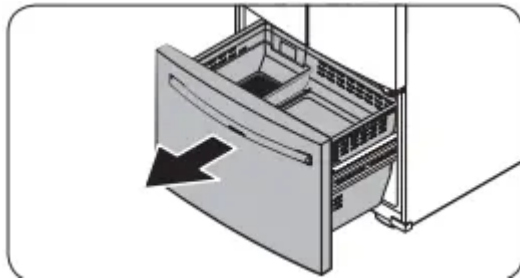

1. Fully open the freezer drawer.

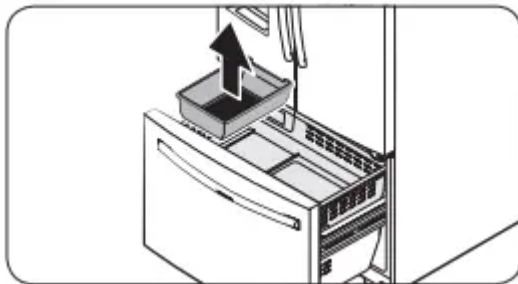

2. Lift the lower ice bucket to remove.

### Upper basket

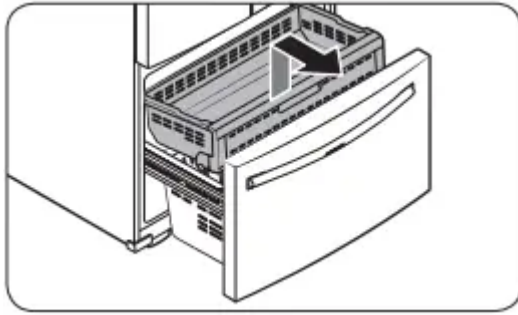

- To remove, fully slide open the freezer drawer. Lift up the front of the upper basket and pull to remove.
- To reinsert, align the front wheels of the upper basket with the end of the lower basket. Slide the upper basket to the front.

### Lower basket

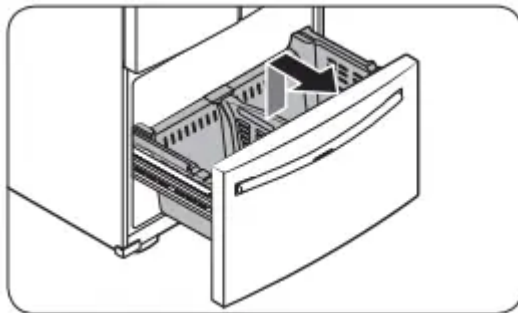

- To remove, first remove the upper basket. Then, tilt up the front of the lower basket to pull out.
- To reinsert, put the basket onto the rail assembly rear side first.



### CAUTION

- Do not twist the basket when removing or reinserting the basket. The basket can be scratched.
- To prevent physical injury, property damage, or suffocation, keep children away from freezer baskets that have been removed.
- Do not remove the divider.
- Put the wheels of the upper basket on the end of the rails of the lower basket. Then, slide the upper basket all the way to the front. Otherwise, the drawer will not open or close properly, which will cause frost to build up.

## Cleaning

### Interior and exterior

 **WARNING**

- Do not use benzene, thinner, home/car detergent, or Clorox™ to clean the refrigerator. They may damage the surface of the refrigerator and cause a fire.
- Do not spray water onto the refrigerator. This may cause electric shock.

Regularly use a dry cloth to remove all foreign substances such as dust or water from the power plug terminals and contact points.

1. Unplug the power cord.
2. Use a moistened, soft, lint-free cloth or paper towel to clean the refrigerator's interior and exterior.
3. When done, use a dry cloth or paper towel to dry well.
4. Plug in the power cord.

**Ice / Water dispenser**

 **CAUTION**

When crushed ice is selected, some residual ice chips may collect in the ice chute. To prevent this, remove the residual ice from the chute using a soft, clean cloth.

**Rubber seals**

If the rubber seals of a door become dirty, the door may not close properly and reducing refrigerator performance and efficiency. Use a mild detergent and damp cloth to clean the rubber seals. Then, dry well with a cloth.

**Rear panel**

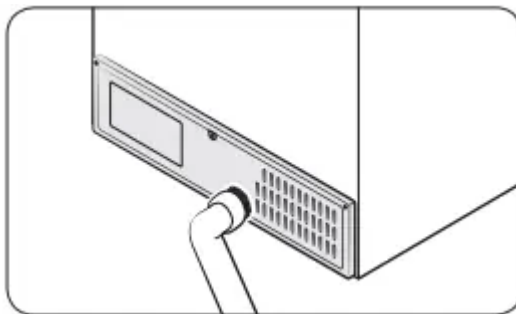

To keep cords and exposed parts of the rear panel free of dirt, vacuum the panel once or twice a year.

 **CAUTION**

Do not remove the rear panel cover. Electric shock may occur.

## Replacement

### Water filter

#### **WARNING**

- Do not use third-party water filters. Use only Samsung-provided or -approved filters.
- Unapproved filters may leak and damage the refrigerator, causing electric shock. Samsung is not responsible for any damage that may occur from use of third-party water filters.

The Filter Reset indicator (**Filter**) turns red to let you know it is time to replace the water filter. Before replacing the filter, make sure the water supply line is shut off.

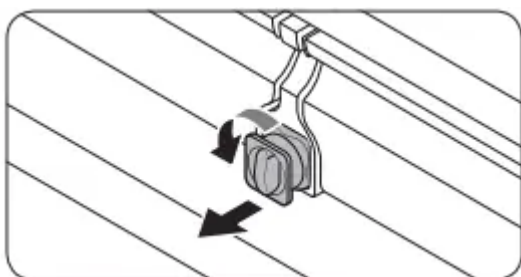

1. Shut off the water supply line.
2. Turn the knob of the filter cartridge 90 degrees counterclockwise (1/4 turn). The filter cartridge unlocks.

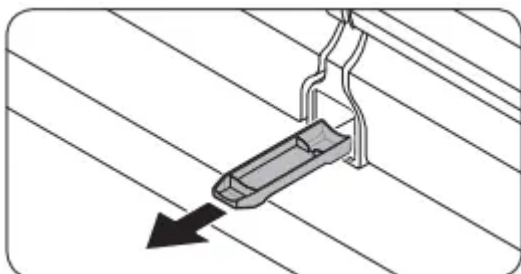

3. Pull out to remove the cartridge.
  - If the water filter is severely contaminated, the cartridge may not be easy to remove. If that is the case, use force to remove the cartridge.
  - To prevent water leaks from the filter opening, pull the cartridge straight out while removing it.
4. Insert a new filter cartridge. Use only Samsung-provided or approved filters.

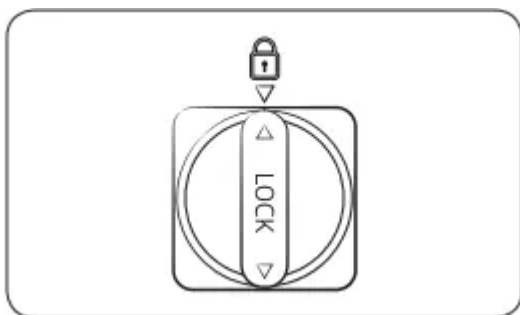

5. Turn the cartridge knob clockwise to lock into place.

6. Press and hold Ice Maker on the main panel for 3 seconds to reset the life cycle detector. The Filter Reset indicator turns off.

7. When you are done replacing the filter, open the water valve and run water through the dispenser for about 7 minutes. This is to remove impurities and air from the water line.

#### **NOTE**

- A newly installed filter may cause the water dispenser to spurt water briefly. This is because air has entered the waterline.
- The replacement process may cause the water dispenser to drip for a short period of time. If it drips, simply wipe up any water on the floor with a dry towel.

#### Reverse osmosis water filtration system

The water pressure of the water supply system to a reverse osmosis water filtration system must be between 30 to 120 psi (206 to 827 kPa). The water pressure of the reverse osmosis water filtration system to the refrigerator's cold water line must be at least 40 psi (276 kPa).

If the water pressure is below these specifications:

- Check if the sediment filter in the reverse osmosis system is blocked. Replace the filter if necessary.
- Refill the water tank in the reverse osmosis system with water.
- If your refrigerator has a water filter, it may further reduce the water pressure when used in conjunction with a reverse osmosis system. Remove the water filter.

For more information or servicing, contact a licensed plumbing professional.

#### **Ordering a new filter**

To purchase a new water filter, contact a local Samsung service center or visit [www.samsungparts.com](http://www.samsungparts.com) on the web.

#### **LED Lamps**

To replace the lamps of the refrigerator, contact a local Samsung service center.

 **WARNING**

- The lamps are not user-serviceable. Do not attempt to replace a lamp yourself. This can cause electric shock.

## Troubleshooting

Before calling for service, review the symptoms and recommended solutions below. If none of the suggested solutions resolve your problem, please visit our website at [www.samsung.com](http://www.samsung.com) or call Samsung Customer Care at 1-800-SAMSUNG (726-7864). Note that you will be charged for any service visits in which no defects were found.

### General

#### 1. Temperature

**Fridge/freezer does not operate. Fridge/freezer temperature is warm.**

**Power cord is not plugged in properly.**

- Properly plug in the power cord.

**Temperature control is not set correctly.**

- Set the temperature lower.

**Refrigerator is located near a heat source or direct sunlight.**

- Keep the refrigerator away from direct sunlight or a heat source.

**Not enough clearance between refrigerator and nearby walls or cabinets.**

- Make sure there is a gap of at least 2.5 inches (5 cm) between the refrigerator back and sides and any nearby walls or cabinets.

**The refrigerator is overloaded. Food is blocking the refrigerator vents.**

- Do not overload the refrigerator. Do not allow food to block vents.

**Fridge/freezer is over-cooling.**

**Temperature control is not set correctly.**

- Set the temperature higher.

**Interior wall is hot.**

**Refrigerator has heat-proof piping in the interior wall.**

- To prevent condensation from forming, the refrigerator has heat-proof piping in the front corners. If the ambient temperature rises, this equipment may not work effectively. This is not a system failure.

## 2. Odors

### **Refrigerator has odors.**

#### **Spoiled food.**

- Clean the refrigerator and remove any spoiled food.

#### **Food with strong odors.**

- Make sure strong smelling food is wrapped airtight.

## 3. Frost

### **Frost around the vents.**

#### **Food is blocking the vents.**

- Make sure no food blocks the refrigerator vents.

### **Frost on interior walls.**

#### **Door is not closed properly.**

- Make sure food does not block the door. Clean the door gasket.

## 4. Condensation

### **Condensation forms on the interior walls.**

#### **If door is left open, moisture enters the refrigerator.**

- Remove the moisture and do not leave a door open for extended periods of time.

#### **Food with high moisture content.**

- Make sure food is wrapped airtight.

## 5. Water/ice (dispenser models only)

### **Water flow is weaker than normal.**

#### **Water pressure is too low.**

- Make sure the water pressure is between 30 to 120 psi to 827 kPa).

### **Ice maker makes a buzzing sound.**

#### **The Ice Maker function is activated, but the water supply to the refrigerator has not been connected.**

- Press **Ice Maker**.

### **Ice maker does not make ice.**

#### **Ice maker has just been installed.**

- You must wait for 12 hours for the refrigerator to make ice.

**Freezer temperature is too high.**

- Set the freezer temperature below 0 °F (-18 °C) or -4 °F (C) in warm ambient air.

**Dispenser panel Lock is activated.**

- Deactivate dispenser panel Lock.

**Ice maker is off.**

- Turn on the ice maker.

**Ice does not dispense.**

**Ice may jam if the ice dispenser is not used for a long time (approx. 3 weeks).**

- If you won't be using the refrigerator for a long time, empty the ice bucket and turn off the ice maker.

**Ice bucket is not properly inserted.**

- Make sure the ice bucket is properly inserted.

**Water line is not connected properly or water supply is not on.**

- Check if the water line is installed correctly. Check if the water line stop cock is closed.

**Water does not dispense.**

**Water line is not connected properly or water supply is not on.**

- Check if the water line is installed correctly. Check if the water line stop cock is closed.

**Dispenser panel Lock is activated.**

- Deactivate dispenser panel Lock.

**A third-party water filter was installed.**

- Use only Samsung-provided or approved filters.
- Unapproved filters may leak and damage the refrigerator.

**Water filter indicator turns on or blinks.**

- Replace the water filter. After replacing, reset the filter indicator sensor.

**Do you hear abnormal sounds from the refrigerator?**

Before calling for service, review the information below. If you still have questions about sounds your refrigerator is making, please call Samsung Customer Care at 1-800-SAMSUNG . Note that you will be charged for any service visits related to normal operating sounds in which no defects were found.

**These sounds are normal.**

- When starting or ending an operation, the refrigerator may make sounds similar to a car engine ignition. As the operation stabilizes, the sounds will decrease.

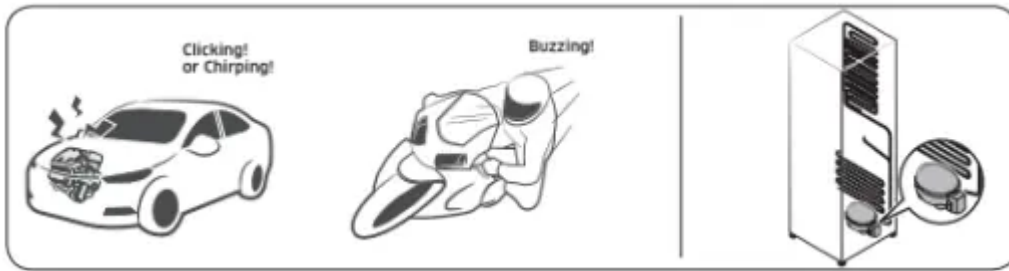

- While the fan is operating, these sounds may occur. When the refrigerator reaches the set temperature, the fan sound will stop.



- During a defrost cycle, water may drip on the defrost heater, causing sizzling sounds.

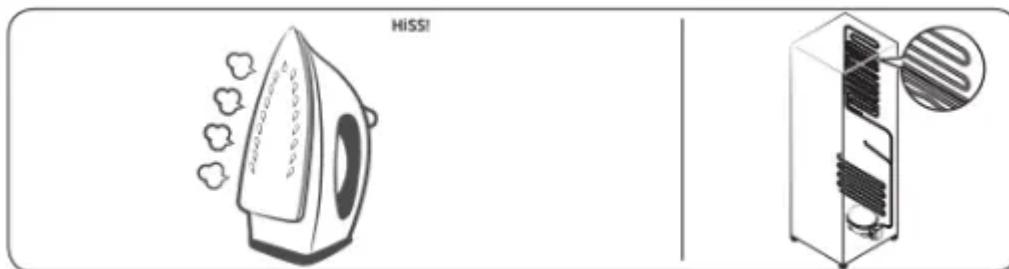

- As the refrigerator cools or freezes, refrigerant gas moves through sealed pipes, causing bubbling sounds.



- As the refrigerator temperature increases or decreases, plastic parts contract and expand, creating knocking noises. These noises occur during the defrosting cycle or when electronic parts are working.

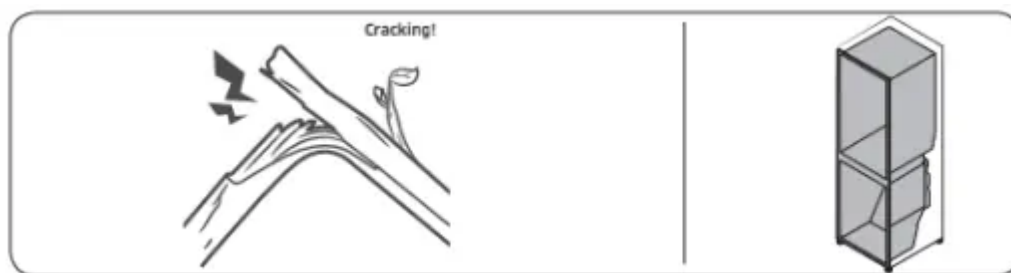

- For ice maker models: When the water valve opens to fill the ice maker, you may hear a buzzing sound.
- Due to pressure equalizing when you open and close the refrigerator door, you may hear a whooshing sound.

### **SmartThings**

#### **Could not find "SmartThings" in the app market.**

- The SmartThings app is designed for Android 6.0 (Marshmallow) or later, iOS 10.0 or later, iPhone 6 or later, and is optimized for Samsung smartphones (Galaxy S and Galaxy Note series).

#### **The SmartThings app fails to operate.**

- The SmartThings app is available for applicable models only.
- The old Samsung Smart Refrigerator app cannot connect with Samsung Smart Home models.

#### **The SmartThings app is installed but is not connected to my refrigerator.**

- You must log into your Samsung account to use the app.
- Make sure that your router is operating normally.
- If you have not connected your refrigerator to the SmartThings App after the app was installed, you must make the connection using the device registration function of the app.

#### **Could not log into the app.**

- You must log into your Samsung account to use the app.
- If you don't have a Samsung account, follow the app's onscreen instructions to create one.

#### **An error message appears when I try to register my refrigerator.**

- Easy Connection may fail due to the distance from your access point (AP) or electrical interference from the surrounding environment. Wait a moment and try again.

### **The SmartThings app is successfully connected to my refrigerator but does not run.**

- Exit and restart the SmartThings app or disconnect and reconnect the router.
- Unplug the power cord of the refrigerator, and then plug it in again after 1 minute.

### **Smart Grid (applicable models only)**

#### **What Do I Need to use the Energy Management and Smart Grid functions?**

To use the Smart Grid (Demand Response) and Energy Management functions on your refrigerator, you need the following:

##### Devices

- A wireless access point (router)
- A Samsung Energy Management-supported refrigerator
- A smartphone

##### Registration

- Connect your refrigerator to your home Wi-Fi network.
- Register for the EMS service with your electric company. Your electric company must have an EMS (Energy Management System) supporting SEP (Smart Energy profile).

##### App

- Download the SmartThings app from the Google Play Store, Apple App Store, or Samsung Galaxy Apps.
- Install and run the SmartThings app on your smartphone.

#### **Why isn't the Energy Management function working normally?**

- Make sure that your home router is operating normally with proper Internet service and connection.
- Make sure that the refrigerator is connected to the AP router).

##### Checkpoints

- Connect your smartphone to the router (AP, Access Point), and then check if you can browse the Internet on the smartphone.

#### **Why isn't the Delay Defrost Capability working normally?**

- Make sure that your home router is operating normally with proper Internet service and connection.

# LIMITED WARRANTY (U.S.A.)

## SAMSUNG REFRIGERATOR

### LIMITED WARRANTY TO ORIGINAL CONSUMER PURCHASER WITH PROOF OF PURCHASE

This SAMSUNG brand product, as supplied and distributed by Samsung Electronics America, Inc. (SAMSUNG) and delivered new, in the original carton to the original consumer purchaser, is warranted by SAMSUNG against manufacturing defects in materials or workmanship for the limited warranty period of:

**One (1) year parts and labor**

**Five (5) years parts and labor on Sealed Refrigeration System Only (Compressor, Evaporator, Condenser, Drier, and Connecting Tubing)**

**Ten (10) years part and Five (5) years labor on Digital Inverter Compressor Only**

This limited warranty is valid only on products purchased and used in the United States that have been installed, operated, and maintained according to the instructions attached to or furnished with the product. To receive warranty service, the purchaser must contact

SAMSUNG at the address or phone number provided below for problem determination and service procedures. Warranty service can only be performed by a SAMSUNG authorized service center. The original dated bill of sale must be presented upon request as proof of purchase to SAMSUNG or SAMSUNG's authorized service center to receive warranty service.

SAMSUNG will provide in-home service within the contiguous United States during the warranty period at no charge, subject to availability of SAMSUNG authorized servicers within the customer's geographic area. If in-home service is not available, SAMSUNG may elect, at its option, to provide transportation of the product to and from an authorized service center. If the product is located in an area where service by a SAMSUNG authorized servicer is not available, you may be responsible for a trip charge or required to bring the product to a SAMSUNG authorized service center for service.

To receive in-home service, product must be unobstructed and accessible to the service agent.

During the applicable warranty period, a product will be repaired, replaced, or the purchase price refunded, at the sole option of SAMSUNG. SAMSUNG may use new or reconditioned parts in repairing a product, or replace the product with a new or reconditioned product. Replacement parts and products are warranted for the remaining portion of the original product's warranty or ninety (90) days, whichever is longer. All replaced parts and products are the property of SAMSUNG and you must return them to SAMSUNG.

## **LIMITED WARRANTY (U.S.A.)**

This limited warranty covers manufacturing defects in materials or workmanship encountered in normal household, noncommercial use of this product and shall not cover the following: damage that occurs in shipment, delivery, installation, and uses for which this product was not intended; damage caused by unauthorized modification or alteration of the product; product where the original factory serial numbers have been removed, defaced, changed in any way, or cannot be readily determined; cosmetic damage including scratches, dents, chips, and other damage to the product's finishes; damage caused by abuse, misuse, pest infestations, accident, fire, floods, or other acts of nature or God; damage caused by use of equipment, utilities, services, parts, supplies, accessories, applications, installations, repairs, external wiring or connectors not supplied or authorized by SAMSUNG; damage caused by incorrect electrical line current, voltage, fluctuations and surges; damage caused by failure to operate and maintain the product according to instructions; in-home instruction on how to use your product; and service to correct installation not in accordance with electrical or plumbing codes or correction of household electrical or plumbing (i.e., house wiring, fuses, or water inlet hoses). The cost of repair or replacement under these excluded circumstances shall be the customer's responsibility.

Visits by an authorized servicer to explain product functions, maintenance or installation are not covered by this limited warranty. Please contact SAMSUNG at the number below for assistance with any of these issues.

## **EXCLUSION OF IMPLIED WARRANTIES**

IMPLIED WARRANTIES, INCLUDING THE IMPLIED WARRANTIES OF MERCHANTABILITY OR FITNESS FOR A PARTICULAR PURPOSE, ARE LIMITED TO ONE YEAR OR THE SHORTEST PERIOD ALLOWED BY LAW. Some states do not allow limitations on how long an implied warranty lasts, so the above limitations or exclusions may not apply to you. This warranty gives you specific rights, and you may also have other rights, which vary from state to state.

## **LIMITATION OF REMEDIES**

YOUR SOLE AND EXCLUSIVE REMEDY IS PRODUCT REPAIR, PRODUCT REPLACEMENT, OR REFUND OF THE PURCHASE PRICE AT SAMSUNG'S OPTION, AS PROVIDED IN THIS LIMITED WARRANTY. SAMSUNG SHALL NOT BE LIABLE FOR SPECIAL, INCIDENTAL OR CONSEQUENTIAL DAMAGES, INCLUDING BUT NOT LIMITED TO TIME AWAY FROM WORK, HOTELS AND/OR RESTAURANT MEALS, REMODELING EXPENSES, LOSS OF REVENUE OR PROFITS, FAILURE TO REALIZE SAVINGS OR OTHER BENEFITS REGARDLESS OF THE LEGAL THEORY ON WHICH THE CLAIM IS BASED, AND EVEN IF SAMSUNG HAS BEEN ADVISED OF THE POSSIBILITY OF SUCH DAMAGES. Some states do not allow exclusion or limitation of

incidental or consequential damages, so the above limitations or exclusions may not apply to you. This warranty gives you specific rights, and you may also have other rights, which vary from state to state.

SAMSUNG does not warrant uninterrupted or error-free operation of the product. No warranty or guarantee given by any other person, firm, or corporation with respect to this product shall be binding on SAMSUNG.

## **Warranty Information (CANADA)**

### **If your refrigerator needs service**

Do not hesitate to call any Samsung Authorized Service Center nearby giving them your name, address and telephone number if your product is not functioning properly.

### **Limited Warranty for Original Purchaser**

This Samsung product is warranted by Samsung Electronics Canada Inc. (hereafter referred to as SECA) against manufacturing defects in material or workmanship for the following periods:

Labor : 1 year (in-home)

Parts : 1 year

Inverter Compressor : 10 years (Part only)

SECA further warrants that if this product fails to operate properly within the specified warranty period and the failure is due to improper workmanship or defective material, SECA will repair or replace the product at its option. In-home service is not available in all areas. Contact us to find out if in-home service is currently available in your area by using the contact information at the back of this warranty.

All warranty repairs or part replacements must be performed by a SECA Authorized Service Center.

### **Obligation to the Original Owner**

The original dated sales receipt must be retained by the customer and is the only acceptable proof of purchase. It must be presented to a SECA Authorized Service Center at the time service is requested before warranty services are rendered. On all carry-in models, transportation to and from the Authorized Service Center is the responsibility of the customer.

## Exclusions of the Warranty

This warranty does not cover damage due to accident, fire, flood, and/or other Acts of God, misuse, incorrect line voltage, improper installation, improper or unauthorized repairs, commercial use, or damage that occurs during shipping. Customer adjustments which are explained in this owners manual are not covered under the terms of this warranty. This warranty will automatically be voided for any unit found with a missing or altered serial number. This warranty is valid only on products purchased and used in Canada.

### Warning

This content is compiled from multiple sources and is provided for reference purposes only. It may not be complete or fully applicable to all situations. If you are unable to resolve your issue, please contact the product manufacturer or an authorized service provider for official support.