

FEATURES AND CONTROLS

OVERVIEW

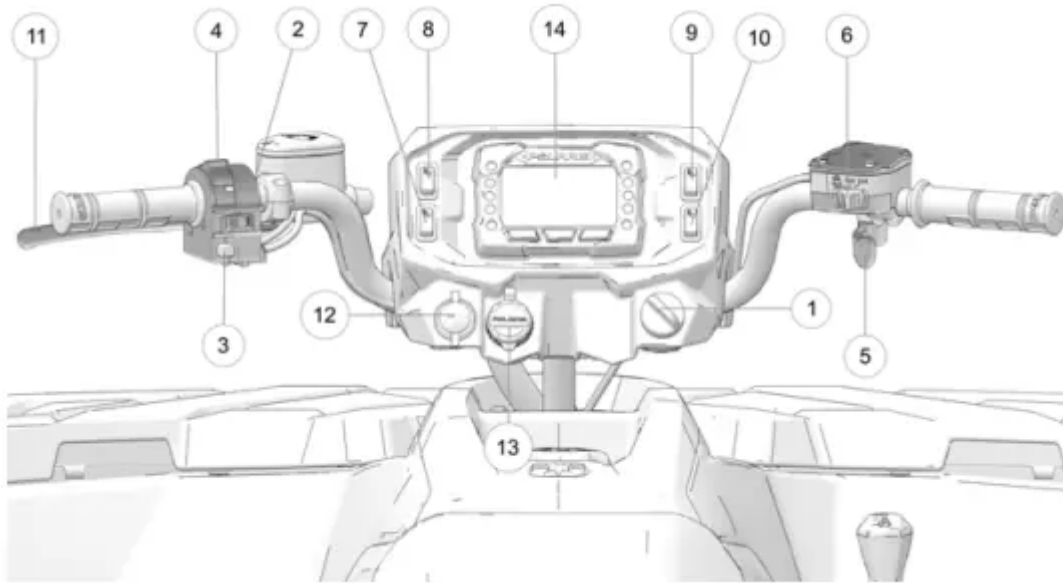

1. Ignition Switch
2. Engine Stop Switch
3. Mode/Reverse Override Switch
4. Headlight Switch
5. Throttle Lever
6. Driveline Switch
7. Drive Mode Switch (if equipped)
8. Auxiliary Switch (if equipped)
9. Thumb Warmer Switch (if equipped)
10. Hand Warmer Switch (if equipped)
11. Brake Lever
12. Auxiliary Outlet
13. Battery Charge Port
14. Digital Display

IGNITION SWITCH

Use the ignition switch 1 to start the engine. The key can be removed from the switch when it is in the OFF position.

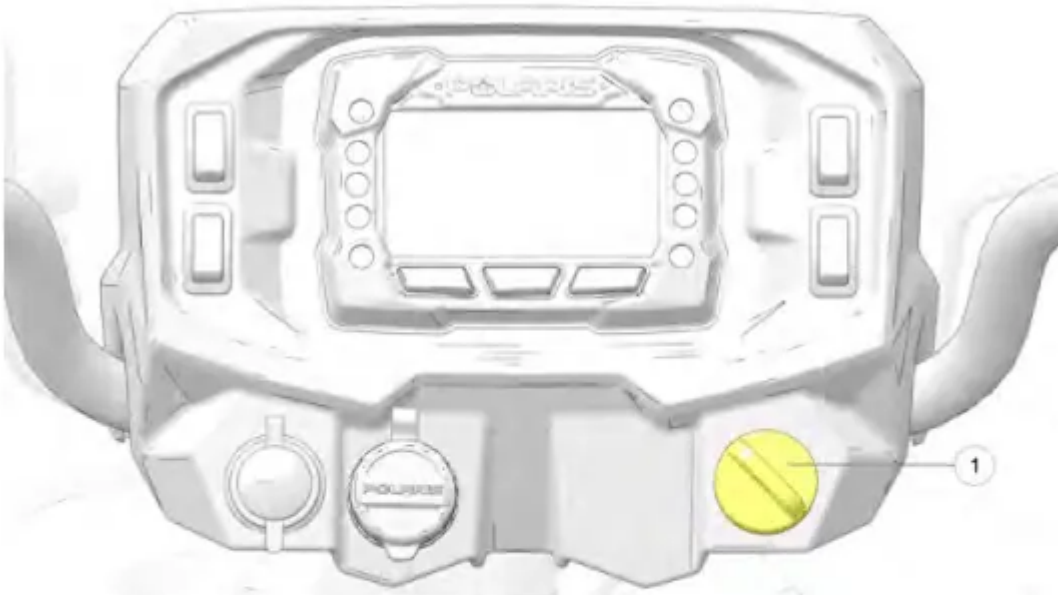

SWITCH POSITION	FUNCTION
OFF	Turn the key to the OFF position to stop the engine. Electrical circuits are off.
RUN	Turn the key the RUN position to activate electrical components. Electrical circuits are on. Electrical equipment can be used.
START	Turn the key to the START position to engage the electric starter. See the Starting the Engine section for starting procedures.

ALL WHEEL DRIVE SYSTEM

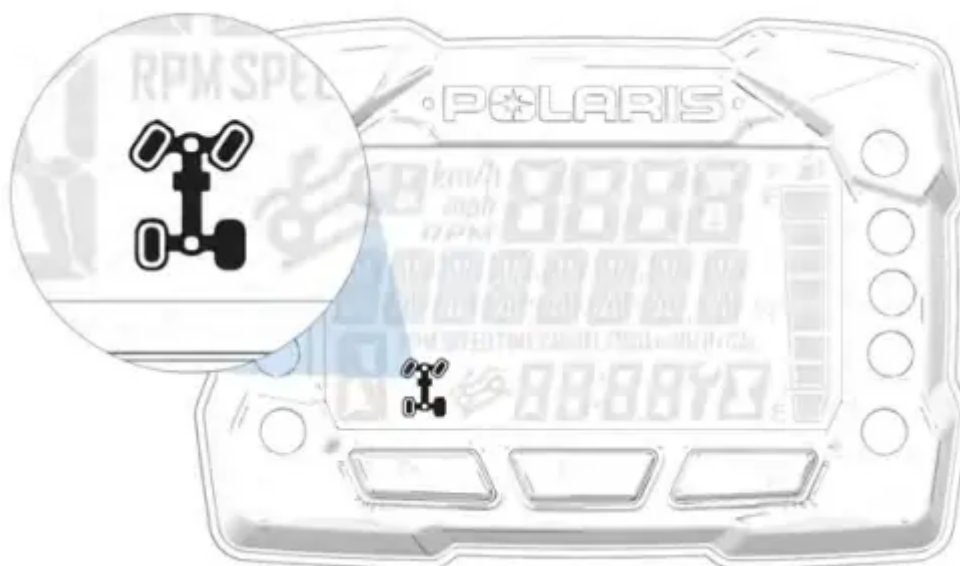

The All Wheel Drive (AWD) system is controlled by the Driveline switch. Engage AWD before getting into conditions where front wheel drive may be needed. If the rear wheels are spinning, release the throttle before switching to AWD.

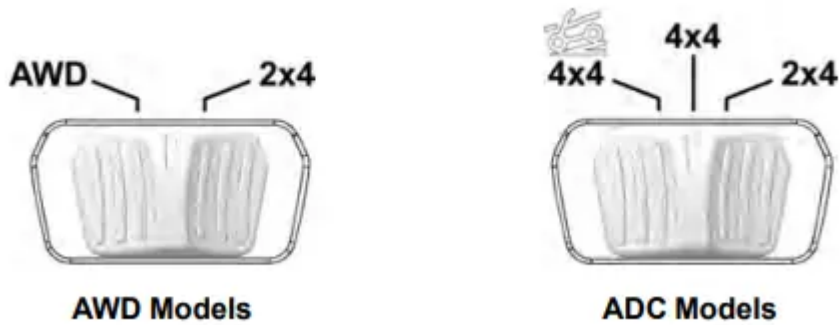

AWD (4X4) MODE



- When the switch is on AWD, the ATV is four-wheel drive, and the AWD indicator icon in the instrument cluster display will be visible.
- When in AWD, the demand drive unit will automatically engage any time the rear wheels lose traction. When the rear wheels regain traction, the demand drive unit will automatically disengage. There is no limit to the length of time the vehicle may remain in AWD. The vehicle automatically engages AWD when operating in reverse if the switch is set to either AWD position.

2X4 MODE



- When the switch is on 2X4, the ATV is in two-wheel drive at all times.

ADC 4X4 MODE (IF EQUIPPED)



- When the switch is on ADC 4X4, the ADC system allows engine braking to all four wheels when the vehicle descends a hill or incline. Always move the 4X4 switch to ADC 4X4 before ascending or descending a hill.

ENGAGING AWD

- The AWD switch may be turned on or off while the vehicle is moving. Initially, the vehicle's electronic system will not enable AWD until the engine RPM is below 3000. Once enabled, AWD remains enabled until the AWD switch is turned off. If the switch is turned off while the demand drive unit is moving, it will not disengage until the rear wheels regain traction.
- Engage the AWD switch before getting into conditions where front wheel drive may be needed. If the rear wheels are spinning, release the throttle before switching to AWD.

OPERATION

SAFE OPERATION PRACTICES

1. Complete the recommended safety training before operating this vehicle. Visit [atvsafety](http://atvsafety.com) website for safety courses and riding tips.
2. Do not allow anyone under 16 years of age to operate this vehicle. Do not allow anyone with cognitive or physical disabilities to operate this vehicle.
3. Never carry a passenger on a 1-up ATV. Never carry more than one passenger on a 2-up ATV.
4. Engine exhaust fumes are poisonous. Never start the engine or let it run in an enclosed area.
5. Before operating, learn how to use the auxiliary brake for emergency situations (if service brakes become inoperable).
6. Operate this vehicle off-road only. Never operate the vehicle on pavement or on any public street, road or highway, including dirt and gravel roads.
7. Use caution and drive at reduced speeds in conditions of reduced visibility such as fog, rain and darkness. Clean headlights frequently and replace burned out headlamps promptly.
8. Drive in a manner appropriate for your skills, your passenger's skills and operating conditions. Never operate at excessive speeds. Never attempt wheelies, jumps, or other

stunts. Never remove your hands from the handlebars while operating, and always keep both feet on the footrests.

9. Never consume alcohol or drugs before or while operating an ATV.
10. Always use the size and type of tires specified for your vehicle. Always maintain proper tire pressure.
11. Never operate a damaged ATV. After any overturn or accident, have a qualified service dealer inspect the entire machine for possible damage.
12. Never operate the ATV on a frozen body of water unless you have independently verified that the ice is sufficiently thick to support the weight and moving force of the ATV, you and your cargo, together with any other vehicles in your party
13. Do not touch hot exhaust system components. Always keep combustible materials away from the exhaust system.
14. Always remove the ignition key when the vehicle is not in use to prevent unauthorized use.

TRAIL ETIQUETTE

- Always practice good etiquette when riding. Allow a safe distance between your vehicle and other vehicles operating in the same area. Communicate to oncoming operators by signaling the number of vehicles in your group. When stopping, move your vehicle to the edge of the trail as far as possible to allow others to pass safely

KNOW YOUR RIDING AREA/TREAD LIGHTLY

- Familiarize yourself with all laws and regulations concerning the operation of this vehicle in your area. Respect the environment in which you ride your vehicle. Find out where the designated riding areas are by contacting your POLARIS dealer, a local riding club, or local officials.
- Help keep our trails open for recreational vehicle use. As an off-road enthusiast, you represent the sport and can set a good example (or a poor example) for others to follow. Tread lightly. Operate with respect for the terrain, avoid littering, and always stay on the designated trails.

VEHICLE BREAK-IN PERIOD

- The break-in period for your new POLARIS vehicle is the first 25 hours of operation, or the time it takes to use the first two tanks full of gasoline. No single action on your part is as important as a proper break-in period. Careful treatment of a new engine and drive components will result in more efficient performance and longer life for these components. Perform the following procedures carefully

ENGINE AND DRIVETRAIN BREAK-IN

1. Fill the fuel tank with gasoline. See the Fuel Tank section for details. Always exercise extreme caution whenever handling gasoline.
2. Check the oil level. See the Oil Check section for reference. Add the recommended oil as needed to maintain the oil level in the safe operating range.
3. Drive slowly at first. Select an open area that allows room to familiarize yourself with vehicle operation and handling.
4. Avoid aggressive use of the brakes.
5. Vary throttle positions. Do not operate at sustained idle.
6. Pull only light loads.
7. Perform regular checks on fluid levels, controls and areas outlined on the daily pre-ride inspection checklist.
8. During the break-in period, change both the oil and the filter at 25 hours or one month.
9. Check the transmission fluid level at 25 hours, check every 25 hours thereafter. Change fluid at 200 hours.
10. Change the front gearcase fluid at 25 hours, change every 200 hours thereafter.

BRAKE SYSTEM BREAK-IN

- Apply only moderate braking force for the first 50 stops. Aggressive or overly forceful braking when the brake system is new could damage brake pads and rotors.

PVT BREAK-IN (CLUTCHES/BELT)

- A proper break-in of your drive belt will ensure a longer life and better performance. To break in a belt, use low gear while varying speeds and avoiding wide open throttle for 5 to 10 miles.
- If a belt fails, always clean any debris from the PVT intake and outlet duct and from the clutch and engine compartments when replacing the belt.

DRIVING PROCEDURES

NEW OPERATOR DRIVING PROCEDURES



1. Wear protective riding gear. See the Safe Riding Gear section.
2. Perform the pre-ride inspection.
3. Place the transmission in PARK.
4. Lock the brake holding latch.
5. Mount the vehicle from the left side.
6. Sit upright with both feet on the footrests and both hands on the handlebars.
7. Start the engine and allow it to warm up.
8. Shift the transmission into gear.
9. Check your surroundings and determine your path of travel.
10. Release the brake holding latch.
11. Slowly depress the throttle with your right thumb and begin driving.
12. Drive slowly. Practice maneuvering and using the throttle and brakes on level surfaces.

TURNING THE VEHICLE

Both rear wheels drive equally at all times. This means that the outside wheel must travel a greater distance than the inside wheel when turning, and the inside tire must slip traction slightly.

1. Slow down.
2. Never turn quickly when carrying cargo.
3. Steer in the direction of the turn.
4. Keep both feet on the footrests.
5. Lean your upper body to the inside of the turn while supporting your weight on the outer footrest. This technique alters the balance of traction between the rear wheels, allowing the turn to be made smoothly. The same leaning technique should be used for turning in reverse.
6. Practice making turns at slow speeds before attempting to turn at faster speeds.

DRIVING ON SLIPPERY SURFACES



Whenever riding on slippery surfaces such as wet trails or loose gravel, or during freezing weather, follow these precautions:

1. Do not operate on excessively rough, slippery or loose terrain.
2. Slow down when entering slippery areas.
3. Engage 4X4 before wheels begin to lose traction.
4. Maintain a high level of alertness, reading the trail and avoiding quick, sharp turns, which can cause skids.
5. Never apply the brakes during a skid. Correct a skid by turning the handlebars in the direction of the skid and shifting your body weight forward.

DRIVING UPHILL

Braking and handling are greatly affected when operating in hilly terrain. Improper procedure could cause loss of control or overturn. Whenever traveling uphill, follow these precautions:

1. Always engage ADC before ascending or descending a hill.
2. Drive straight uphill.
3. Avoid steep hills. Maximum incline is: 25°
4. Always check the terrain carefully before ascending any hill.
5. Never climb hills with excessively slippery or loose surfaces.
6. Keep both feet on the footrests.
7. Shift body weight uphill.
8. Proceed at a steady rate of speed and throttle opening. Opening the throttle suddenly could cause the ATV to flip over backwards.

9. Never go over the top of any hill at high speed. An obstacle, a sharp drop, or another vehicle or person could be on the other side of the hill.
10. Remain alert and be prepared to take emergency action. This may include quick dismounting of the vehicle.

DRIVING DOWNHILL



When driving downhill, follow these precautions:

1. Always check the terrain carefully before descending a hill.
2. Always engage ADC mode before ascending or descending a hill.
3. Avoid steep hills. Maximum incline is 25°
4. Always descend a hill with the transmission in forward gear. Do not descend a hill with the transmission in neutral.
5. Slow down. Never travel down a hill at high speed.
6. Drive straight downhill. Avoid traveling down a hill at an angle, which would cause the vehicle to lean sharply to one side.
7. Shift body weight uphill.
8. Apply the brakes slightly to aid in slowing. Applying the brakes too firmly may cause the rear wheels to lock, which could result in loss of control.

DRIVING ON A SIDEHILL (SIDEHILLING)



Driving on a sidehill is not recommended. Improper procedure could cause loss of control or overturn. Avoid crossing the side of any hill unless absolutely necessary. If crossing a sidehill is unavoidable, follow these precautions:

1. Slow down.
2. Avoid crossing the side of a steep hill.
3. Lean into the hill, transferring your upper body weight toward the hill while keeping your feet on the footrests.
4. If the vehicle begins to tip, quickly turn the front wheel downhill, if possible, or dismount on the uphill side immediately!

TURNING AROUND ON A HILL (K-TURN)

If the vehicle stalls while climbing a hill, never back it down the hill! Use the Kturn to turn around.

1. Stop and lock the parking brake while keeping body weight uphill.
2. Always move the 4X4 switch to ADC 4X4 before ascending or descending a hill. See the Switch Location section for details.
3. Leave the transmission in forward and shut off the engine.
4. Dismount on the uphill side of the vehicle, or on the left if the vehicle is pointing straight uphill.
5. Staying uphill of the vehicle, turn the handlebars full left.
6. While holding the brake lever, release the parking brake lock and slowly allow the vehicle to roll around to your right until it's pointing across the hill or slightly downward.
7. Lock the parking brake. Remount the vehicle from the uphill side, keeping body weight uphill. Start the engine with the transmission still in forward.
8. Release the parking brake and proceed slowly, controlling speed with the brake lever, until the vehicle is on more level ground.

STARTING THE ENGINE

1. Position the vehicle on a level surface outdoors or in a well-ventilated area.
2. Place the transmission in PARK.
3. Lock the parking brake.
4. Sit on the vehicle and move the engine stop switch to RUN.
5. Turn the ignition key past the ON position to engage the starter. Activate the starter for a maximum of five seconds, releasing the key when the engine starts.
6. If the engine does not start, return the key to the OFF position and wait five seconds before attempting to start again. Activate the starter for another five seconds if necessary. Repeat this procedure until the engine starts.

COLD WEATHER OPERATION

- If the vehicle is used year-round, check the oil level frequently. A rising oil level could indicate the accumulation of contaminants such as water or excess fuel in the bottom of the crankcase. Water in the bottom of the crankcase can lead to engine damage and must be drained. Water accumulation increases as outside temperature decreases.

PARKING THE VEHICLE

1. Stop the vehicle on a level surface. When parking inside a garage or other structure, be sure that the structure is well ventilated and that the vehicle is not close to any source of flame or sparks, including any appliance with pilot lights.
2. Place the transmission in PARK.
3. Turn the engine off.
4. Slowly release the brake pedal and make sure the transmission is in PARK before exiting the vehicle.
5. Remove the ignition key to prevent unauthorized use.

PARKING ON AN INCLINE

Avoid parking on an incline if possible. If it's unavoidable, follow these precautions:

1. Stop the engine.
2. Lock the parking brake.
3. Place the transmission in PARK
4. Always block the rear wheels on the downhill side.

MAINTENANCE

ENGINE OIL

- Always check and change the oil at the intervals outlined in the Periodic Maintenance Chart. Always use the recommended engine oil. Always change the oil filter whenever changing oil.
- Pay special attention to the oil level. A rise in oil level during cold weather can indicate contaminants collecting in the oil sump or crankcase. Change oil immediately if the oil level begins to rise. Monitor the oil level, and if it continues to rise, discontinue use and determine the cause. Your dealer can assist.

OIL RECOMMENDATIONS

- Always change the oil filter whenever changing oil.
- POLARIS recommends the use of POLARIS PS-4 Full Synthetic 5W-50 4-cycle oil or a similar oil for this engine. Oil may need to be changed more frequently if POLARIS oil is not used. Always use 5W-50 oil. Follow the manufacturer's recommendations for ambient temperature operation.
- See the Lubrication Guide section for fluid recommendations, capacities and plug torques

OIL LEVEL

To check the oil level, do the following:

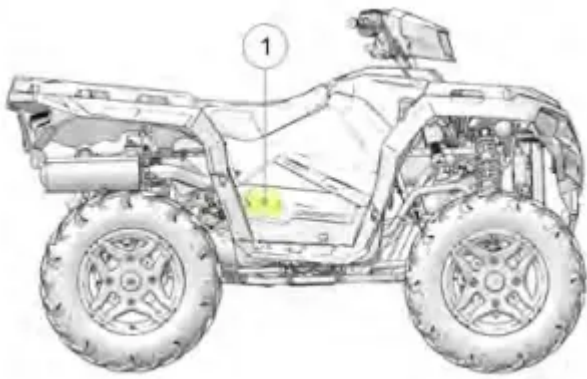

1. Position the vehicle on a level surface.
2. Access the oil dipstick and fill tube from the right side of the ATV 1. Remove the dipstick. Wipe it dry with a clean cloth.
3. Reinstall and tighten the dipstick.
4. Remove the dipstick and check the oil level
5. Add the recommended fluid as needed. Maintain the oil level in the safe range between the FULL and ADD marks. Do not overfill.

6. Reinstall and tighten the dipstick.

OIL CHANGE

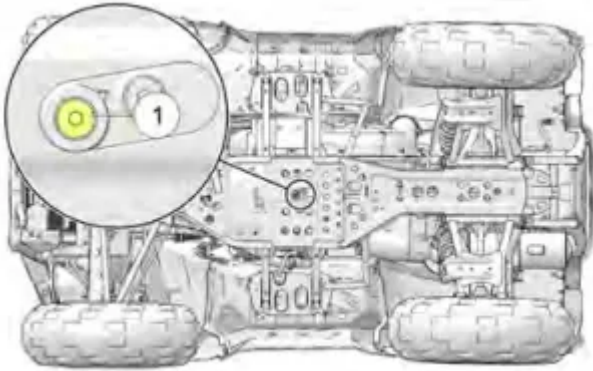

See the fluid recommendation table for capacities and plug torques. Always change the oil at the intervals outlined in the Periodic Maintenance Chart beginning on page 100. Always change the oil filter whenever changing oil.

1. Position the vehicle on a level surface.
2. Start the engine. Allow it to warm up at idle for two to three minutes.
3. Stop the engine.
4. Clean the area around the drain plug 1
5. Place a drain pan under the crankcase.
6. Remove the drain plug 1. Allow the oil to drain completely.
7. Install a new sealing washer on the drain plug. The sealing surfaces on drain plug and crankcase should be clean and free of burrs, nicks or scratches.
8. Reinstall the drain plug. Torque to specification.

TRANSMISSION OIL

Always check and change the transmission oil at the intervals outlined in the Periodic Maintenance Interval section of this manual. See the Fluid Recommendation table for capacities and plug torques. Maintain the oil level at the bottom of the fill plug hole. The fill plug is located on the right side of the ATV behind the footwell. The drain plug is located on the bottom rear side of the gearcase.

OIL CHECK

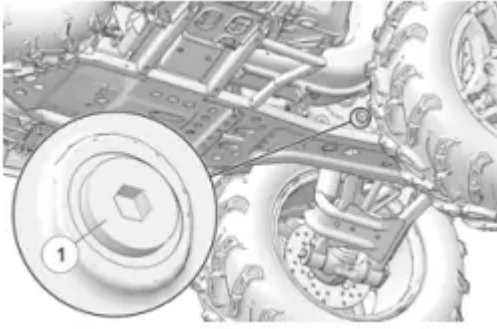

1. Remove the footwell.
2. Remove the fill plug 1. Check the oil level.
3. Slowly add the recommended fluid as needed to bring the level to the bottom of the fill hole threads.
4. Reinstall the fill plug. Torque to specification.
5. Reinstall the footwell.

OIL CHANGE

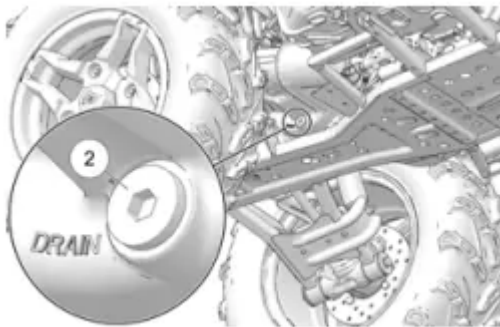

1. Place a drain pan under the gearcase. Remove the drain plug 2. Allow the oil to drain completely.
2. Clean and reinstall the drain plug. Torque to specification.
3. Remove the fill plug. Slowly add the proper amount of the recommended oil.
4. Reinstall the fill plug. Torque to specification.
5. Check for leaks.
6. Reinstall the footwell.
7. Dispose of used oil properly

SPECIFICATIONS

SPORTSMAN 450 H.O. / 450 H.O. EPS

SPORTSMAN 450 H.O. / 450 H.O. EPS	
Maximum Weight Capacity	485 lbs. (220 kg) (operator, cargo, accessories)
Manufactured Weight	450 HO: 710 lbs. (322 kg) 450 HO EPS: 732 lbs. (332 kg)
Fuel Capacity	4.5 gal. (17 L)
Engine Oil Capacity	2 qts. (1.9 L)
Coolant Capacity	2.7 qts. (2.5 L)
Demand Drive Fluid Capacity	9 oz. (265 ml)
Transmission Oil Capacity	32 oz. (948 ml)
Front Rack/Storage Box Capacity	5 Gal (18.9 L)
Rear Rack Capacity	180 lbs. (81.6 kg)
Receiver Hitch Tongue Capacity	120 lbs. (54 kg) (Rear rack capacity and tongue weight not to exceed 180 lbs./81.6 kg)
Hitch Towing Rating	1350 lbs. (612 kg)
Front Hitch Maximum Towed Load (Level Ground)	850 lbs. (386 kg)
Front Maximum Vertical Hitch Weight	85 lbs. (39 kg)
Overall Length	83 in. (211 cm)
Overall Width	48 in. (122 cm)
Overall Height	48 in. (122 cm)
Wheelbase	50.5 in. (128.3 cm)
Ground Clearance	11.5 in. (29.2 cm)
Minimum Turning Radius	65 in. (165 cm) unloaded
Engine	Single overhead cam, 2 valve 4 stroke single cylinder
Displacement	499 cc
Bore x Stroke	93 mm x 73.6 mm
Alternator Output	660 W @ 5000 RPM



SPORTSMAN 450 H.O. / 450 H.O. EPS	
Compression Ratio	10:1
Starting System	Electric
Ignition System	ECU
Idle RPM	1200 +/- 50
Spark Plug Type / Gap	5924 / 0.76-0.92 mm
Lubrication System	Wet Sump
Driving System Type	Automatic PVT (POLARIS Variable Transmission)
Front Suspension	Sealed MacPherson MacPherson Ride® strut with 8.2" (21 cm) travel
Rear Suspension	Sealed Dual A-Arm, IRS 9.5" (24 cm) Travel
Transmission	H/L/N/R/P
Gear Reduction, Low	23.91:1
Gear Reduction, Reverse	21.74:1
Gear Reduction, High	12.79:1
Drive Ratio, Front	3.82:1
Drive Ratio, Rear	3.7:1
Tires/Pressure, Front	25x8-12 / 7 psi (48.3 kPa)
Tires/Pressure, Rear	25x10-12 / 7 psi (48.3 kPa)
Brakes, Front/Rear	Single-Control Hydraulic Disc
Brakes, Auxiliary	Foot-Activated Hydraulic Disc
Brake, Parking	Hydraulic lock, all wheel
Headlight	1 Single Beam on Headlight POD (50 watt) 2 Single Beam on Bumper (55 watt)
Taillights	Non-EPS: Single LED Brakelight / Taillight (26.9 watts) EPS: Dual LED Brakelights (8.26 watts) / Taillights (26.9 watts)
Instrument Cluster	LCD

SPORTSMAN 450 H.O. UTILITY

SPORTSMAN 450 H.O. UTILITY	
Maximum Weight Capacity	485 lbs. (220 kg) (operator, cargo, accessories)
Manufactured Weight	767 lbs. (348 kg)
Fuel Capacity	4.5 gal. (17 L)
Engine Oil Capacity	2 qts. (1.9 L)
Coolant Capacity	2.7 qts. (2.5 L)
Demand Drive Fluid Capacity	9 oz. (265 ml)
Transmission Oil Capacity	32 oz. (948 ml)
Front Rack/Storage Box Capacity	5 Gal. (18.9 L)
Rear Rack Capacity	180 lbs. (81.6 kg)
Receiver Hitch Tongue Capacity	120 lbs. (54 kg) (Rear rack capacity and tongue weight not to exceed 180 lbs./81.6 kg)
Hitch Towing Rating	1350 lbs. (612 kg)
Front Hitch Maximum Towed Load (Level Ground)	850 lbs. (386 kg)
Front Maximum Vertical Hitch Weight	85 lbs. (39 kg)
Overall Length	83 in. (211 cm)
Overall Width	48 in. (122 cm)
Overall Height	48 in. (122 cm)
Wheelbase	50.5 in. (128.3 cm)
Ground Clearance	11.5 in. (29.2 cm)
Minimum Turning Radius	65 in. (165 cm) unloaded
Engine	Single overhead cam, 2 valve 4 stroke single cylinder
Displacement	499 cc
Bore x Stroke	93 mm x 73.6 mm
Alternator Output	660 W @ 5000 RPM
Compression Ratio	10:1

SPORTSMAN 450 H.O. UTILITY	
Starting System	Electric
Ignition System	ECU
Idle RPM	1200 +/- 50
Spark Plug Type / Gap	5924 / 0.76-0.92 mm
Lubrication System	Wet Sump
Driving System Type	Automatic PVT (POLARIS Variable Transmission)
Front Suspension	Sealed MacPherson MacPherson Ride® strut with 8.2" (21 cm) travel
Rear Suspension	Sealed Dual A-Arm, IRS 9.5" (24 cm) Travel
Transmission	H/L/N/R/P
Gear Reduction, Low	23.91:1
Gear Reduction, Reverse	21.74:1
Gear Reduction, High	12.79:1
Drive Ratio, Front	3.82:1
Drive Ratio, Rear	3.7:1
Tires/Pressure, Front	25x8-12 / 7 psi (48.3 kPa)
Tires/Pressure, Rear	25x10-12 / 7 psi (48.3 kPa)
Brakes, Front/Rear	Single-Control Hydraulic Disc
Brakes, Auxiliary	Foot-Activated Hydraulic Disc
Brake, Parking	Hydraulic lock, all wheel
Headlight	1 Single Beam on Headlight POD (50 watt) 2 Single Beam on Bumper (55 watt)
Taillights	Single LED Brakelight / Taillight (26.9 watts)
Instrument Cluster	LCD

SPORTSMAN 570 / 570 EPS / PREMIUM



SPORTSMAN 570 / 570 EPS / PREMIUM

Maximum Weight Capacity	485 lbs. (220 kg) (operator, cargo, accessories)
Manufactured Weight	570: 713 lbs. (323 kg) 570 EPS: 765 lbs. (347 kg) 570 EPS Premium: 761 lbs. (345 kg)
Fuel Capacity	4.5 gal. (17 L)
Engine Oil Capacity	2 qts. (1.9 L)
Coolant Capacity	2.7 qts. (2.5 L)
Demand Drive Fluid Capacity	9 oz. (265 ml)
Transmission Oil Capacity	32 oz. (948 ml)
Front Rack/Storage Box Capacity	5 Gal. (18.9 L)
Rear Rack Capacity	180 lbs. (81.6 kg)
Receiver Hitch Tongue Capacity	120 lbs. (55 kg)* *Rear rack capacity and tongue weight not to exceed 180 lbs./81.6 kg
Hitch Towing Rating	1350 lbs. (612 kg)
Front Hitch Maximum Towed Load (Level Ground)	850 lbs. (386 kg)
Front Maximum Vertical Hitch Weight	85 lbs. (39 kg)
Overall Length	83 in. (211 cm)
Overall Width	48 in. (122 cm)
Overall Height	48 in. (122 cm)
Wheelbase	50.5 in. (128.3 cm)
Ground Clearance	11.5 in. (29.2 cm)
Minimum Turning Radius	65 in. (165 cm) unloaded
Engine	Dual overhead cam, 4 valve 4 stroke single cylinder
Displacement	567 cc
Bore x Stroke	99mm x 73.6mm
Alternator Output	660 W @ 5000 RPM

SPORTSMAN 570 / 570 EPS / PREMIUM	
Compression Ratio	10:1
Starting System	Electric
Ignition System	ECU
Idle RPM	1200 +/- 50
Spark Plug Type / Gap	MR7F / 0.7-0.8 mm
Lubrication System	Wet Sump
Driving System Type	Automatic PVT (POLARIS Variable Transmission)
Front Suspension	Sealed MacPherson MacPherson Ride® strut with 8.2" (21 cm) travel
Rear Suspension	Sealed Dual A-Arm, IRS 9.5" (24 cm) Travel
Transmission	H/L/N/R/P
Gear Reduction, Low	23.91:1
Gear Reduction, Reverse	21.74:1
Gear Reduction, High	11.12:1 (EBS Models) 9.75:1 (Non-EBS Models)
Drive Ratio, Front	3.82:1
Drive Ratio, Rear	3.7:1
Tires/Pressure, Front	25x8-12 / 7 psi (48.3 kPa)
Tires/Pressure, Rear	25x10-12 / 7 psi (48.3 kPa)
Brakes, Front/Rear	Single-Control Hydraulic Disc
Brakes, Auxiliary	Foot-Activated Hydraulic Disc
Brake, Parking	Hydraulic lock, all wheel
Headlight	1 Single Beam on Headlight POD (50 watt) 2 Single Beam on Bumper (55 watt)
Brakelights / Taillights	Non-EPS: Single LED Brakelight / Taillight (26.9 watts) EPS: Dual LED Brakelights (8.26 watts) / Taillights (26.9 watts)
Instrument Cluster	LCD

SPORTSMAN 570 UTILITY

SPORTSMAN 570 / 570 EPS UTILITY

Maximum Weight Capacity	485 lbs. (220 kg) (operator, cargo, accessories)
Manufactured Weight	570: 767 lbs. (348 kg) 570 EPS: 799 lbs. (362 kg)
Fuel Capacity	4.5 gal. (17 L)
Engine Oil Capacity	2 qts. (1.9 L)
Coolant Capacity	2.7 qts. (2.5 L)
Demand Drive Fluid Capacity	9 oz. (265 ml)
Transmission Oil Capacity	32 oz. (948 ml)
Front Rack/Storage Box Capacity	5 Gal. (18.9 L)
Rear Rack Capacity	180 lbs. (81.6 kg)
Receiver Hitch Tongue Capacity	120 lbs. (55 kg)* *Rear rack capacity and tongue weight not to exceed 180 lbs./81.6 kg
Hitch Towing Rating	1350 lbs. (612 kg)
Front Hitch Maximum Towed Load (Level Ground)	850 lbs. (386 kg)
Front Maximum Vertical Hitch Weight	85 lbs. (39 kg)
Overall Length	83 in. (211 cm)
Overall Width	48 in. (122 cm)
Overall Height	48 in. (122 cm)
Wheelbase	50.5 in. (128.3 cm)
Ground Clearance	11.5 in. (29.2 cm)
Minimum Turning Radius	65 in. (165 cm) unloaded
Engine	Dual overhead cam, 4 valve 4 stroke single cylinder
Displacement	567 cc
Bore x Stroke	99mm x 73.6mm
Alternator Output	660 W @ 5000 RPM



SPORTSMAN 570 / 570 EPS UTILITY	
Compression Ratio	10:1
Starting System	Electric
Ignition System	ECU
Idle RPM	1200 +/- 50
Spark Plug Type / Gap	MR7F / 0.7-0.8 mm
Lubrication System	Wet Sump
Driving System Type	Automatic PVT (POLARIS Variable Transmission)
Front Suspension	Sealed MacPherson MacPherson Ride® strut with 8.2" (21 cm) travel
Rear Suspension	Sealed Dual A-Arm, IRS 9.5" (24 cm) Travel
Transmission	H/L/N/R/P
Gear Reduction, Low	23.91:1
Gear Reduction, Reverse	21.74:1
Gear Reduction, High	11.12:1 (EBS Models) 9.75:1 (Non-EBS Models)
Drive Ratio, Front	3.82:1
Drive Ratio, Rear	3.7:1
Tires/Pressure, Front	25x8-12 / 7 psi (48.3 kPa)
Tires/Pressure, Rear	25x10-12 / 7 psi (48.3 kPa)
Brakes, Front/Rear	Single-Control Hydraulic Disc
Brakes, Auxiliary	Foot-Activated Hydraulic Disc
Brake, Parking	Hydraulic lock, all wheel
Headlight	1 Single Beam on Headlight POD (50 watt) 2 Single Beam on Bumper (55 watt)
Taillights	Non-EPS: Single LED Brakelight / Taillight (26.9 watts) EPS: Dual LED Brakelights (8.26 watts) / Taillights (26.9 watts)
Instrument Cluster	LCD

SPORTSMAN 570 HD ULTIMATE UTILITY LE



SPORTSMAN 570 HD ULTIMATE UTILITY LE

Maximum Weight Capacity	485 lbs. (220 kg) (operator, cargo, accessories)
Manufactured Weight	796 lbs. (361 kg)
Fuel Capacity	4.5 gal. (17 L)
Engine Oil Capacity	2 qts. (1.9 L)
Coolant Capacity	2.7 qts. (2.5 L)
Demand Drive Fluid Capacity	9 oz. (265 ml)
Transmission Oil Capacity	32 oz. (948 ml)
Front Rack/Storage Box Capacity	5 Gal. (18.9 L)
Rear Rack Capacity	180 lbs. (81.6 kg)
Receiver Hitch Tongue Capacity	120 lbs. (55 kg)* *Rear rack capacity and tongue weight not to exceed 180 lbs./81.6 kg
Hitch Towing Rating	1350 lbs. (612 kg)
Front Hitch Maximum Towed Load (Level Ground)	850 lbs. (386 kg)
Front Maximum Vertical Hitch Weight	85 lbs. (39 kg)
Overall Length	83 in. (211 cm)
Overall Width	48 in. (122 cm)
Overall Height	48 in. (122 cm)
Wheelbase	50.5 in. (128.3 cm)
Ground Clearance	11.5 in. (29.2 cm)
Minimum Turning Radius	65 in. (165 cm) unloaded
Engine	Dual overhead cam, 4 valve 4 stroke single cylinder
Displacement	567 cc
Bore x Stroke	99mm x 73.6mm
Alternator Output	660 W @ 5000 RPM
Compression Ratio	10:1

SPORTSMAN 570 HD ULTIMATE UTILITY LE	
Starting System	Electric
Ignition System	ECU
Idle RPM	1200 +/- 50
Spark Plug Type / Gap	MR7F / 0.7-0.8 mm
Lubrication System	Wet Sump
Driving System Type	Automatic PVT (POLARIS Variable Transmission)
Front Suspension	Sealed MacPherson MacPherson Ride® strut with 8.2" (21 cm) travel
Rear Suspension	Sealed Dual A-Arm, IRS 9.5" (24 cm) Travel
Transmission	H/L/N/R/P
Gear Reduction, Low	23.91:1
Gear Reduction, Reverse	21.74:1
Gear Reduction, High	11.12:1
Drive Ratio, Front	3.82:1
Drive Ratio, Rear	3.7:1
Tires/Pressure, Front	25x8-12 / 7 psi (48.3 kPa)
Tires/Pressure, Rear	25x10-12 / 7 psi (48.3 kPa)
Brakes, Front/Rear	Single-Control Hydraulic Disc
Brakes, Auxiliary	Foot-Activated Hydraulic Disc
Brake, Parking	Hydraulic lock, all wheel
Headlight	1 Single Beam on Headlight POD (50 watt) 2 Single Beam on Bumper (55 watt)
Brakelights / Taillights	Dual LED Brakelights (8.26 watts) / Taillights (26.9 watts)
Instrument Cluster	LCD

SPORTSMAN 570 TRAIL

SPORTSMAN 570 TRAIL

Maximum Weight Capacity	485 lbs. (220 kg) (operator, cargo, accessories)
Manufactured Weight	869 lbs. (394 kg)
Fuel Capacity	4.5 gal. (17 L)
Engine Oil Capacity	2 qts. (1.9 L)
Coolant Capacity	2.7 qts. (2.5 L)
Demand Drive Fluid Capacity	9 oz. (265 ml)
Transmission Oil Capacity	32 oz. (948 ml)
Front Rack/Storage Box Capacity	5 Gal. (18.9 L)
Rear Rack Capacity	180 lbs. (81.6 kg)
Receiver Hitch Tongue Capacity	120 lbs. (55 kg)* *Rear rack capacity and tongue weight not to exceed 180 lbs./81.6 kg
Hitch Towing Rating	1350 lbs. (612 kg)
Overall Length	83 in. (211 cm)
Overall Width	48 in. (122 cm)
Overall Height	48 in. (122 cm)
Wheelbase	50.5 in. (128.3 cm)
Ground Clearance	11.5 in. (29.2 cm)
Minimum Turning Radius	65 in. (165 cm) unloaded
Engine	Dual overhead cam, 4 valve 4 stroke single cylinder
Displacement	567 cc
Bore x Stroke	99mm x 73.6mm
Alternator Output	660 W @ 5000 RPM
Compression Ratio	10:1
Starting System	Electric
Ignition System	ECU

SPORTSMAN 570 TRAIL	
Idle RPM	1200 +/- 50
Spark Plug Type / Gap	MR7F / 0.7-0.8 mm
Lubrication System	Wet Sump
Driving System Type	Automatic PVT (POLARIS Variable Transmission)
Front Suspension	Sealed MacPherson MacPherson Ride® Dual A-Arm with 8.9 in. (22.6 cm) Travel
Rear Suspension	Sealed Dual A-Arm, IRS 9.5" (24 cm) Travel
Transmission	H/L/N/R/P
Gear Reduction, Low	23.91:1
Gear Reduction, Reverse	21.74:1
Gear Reduction, High	9.75:1
Drive Ratio, Front	3.82:1
Tires/Pressure, Front	26x8-14 / 7 psi (48.3 kPa)
Tires/Pressure, Rear	26x10-14 / 7 psi (48.3 kPa)
Brakes, Front/Rear	Single-Control Hydraulic Disc
Brakes, Auxiliary	Foot-Activated Hydraulic Disc
Brake, Parking	Hydraulic lock, all wheel
Headlight	1 Single Beam on Headlight POD (50 watt) 2 Single Beam on Bumper (55 watt)
Brakelights / Taillights	EPS: Dual LED Brakelights (8.26 watts) / Taillights (26.9 watts)
Instrument Cluster	LCD

SPORTSMAN 570 ULTIMATE TRAIL LE

SPORTSMAN 570 ULTIMATE TRAIL LE	
Maximum Weight Capacity	485 lbs. (220 kg) (operator, cargo, accessories)
Manufactured Weight	830 lbs. (376 kg)
Fuel Capacity	4.5 gal. (17 l)
Engine Oil Capacity	2 qts. (1.9 l)
Coolant Capacity	2.7 qts. (2.5 l)
Demand Drive Fluid Capacity	9 oz. (265 ml)
Transmission Oil Capacity	32 oz. (948 ml)
Front Rack/Storage Box Capacity	5 Gal. (18.9 l)
Rear Rack Capacity	180 lbs. (81.6 kg)
Receiver Hitch Tongue Capacity	120 lbs. (55 kg)* *Rear rack capacity and tongue weight not to exceed 180 lbs./81.6 kg
Hitch Towing Rating	1350 lbs. (612 kg)
Overall Length	83 in. (211 cm)
Overall Width	48 in. (122 cm)
Overall Height	48 in. (122 cm)
Wheelbase	50.5 in. (128.3 cm)
Ground Clearance	11.5 in. (29.2 cm)
Minimum Turning Radius	65 in. (165 cm) unloaded
Engine	Dual overhead cam, 4 valve 4 stroke single cylinder
Displacement	567 cc
Bore x Stroke	99mm x 73.6mm
Alternator Output	660 W @ 5000 RPM
Compression Ratio	10:1
Starting System	Electric
Ignition System	ECU



SPORTSMAN 570 ULTIMATE TRAIL LE	
Idle RPM	1200 +/- 50
Spark Plug Type / Gap	MR7F / 0.7-0.8 mm
Lubrication System	Wet Sump
Driving System Type	Automatic PVT (POLARIS Variable Transmission)
Front Suspension	Sealed MacPherson MacPherson Ride® Dual A-Arm with 8.9 in. (22.6 cm) Travel
Rear Suspension	Sealed Dual A-Arm, IRS 9.5" (24 cm) Travel
Transmission	H/L/N/R/P
Gear Reduction, Low	23.91:1
Gear Reduction, Reverse	21.74:1
Gear Reduction, High	11.12:1
Drive Ratio, Front	3.82:1
Tires/Pressure, Front	26x8-14 / 7 psi (48.3 kPa)
Tires/Pressure, Rear	26x10-14 / 7 psi (48.3 kPa)
Brakes, Front/Rear	Single-Control Hydraulic Disc
Brakes, Auxiliary	Foot-Activated Hydraulic Disc
Brake, Parking	Hydraulic lock, all wheel
Headlight	1 Single Beam on Headlight Pod (83 watt) High Beam on Bumper (77 watt) Low Beam on Bumper (58 watt)
Brakelights / Taillights	Dual LED Brakelights (8.26 watts) / Taillights (26.9 watts)
Instrument Cluster	LCD

SPORTSMAN 570 HUNT EDITION

SPORTSMAN 570 HUNT EDITION

Maximum Weight Capacity	485 lbs. (220 kg) (operator, cargo, accessories)
Manufactured Weight	879 lbs. (399 kg)
Fuel Capacity	4.5 gal. (17 l)
Engine Oil Capacity	2 qts. (1.9 l)
Coolant Capacity	2.7 qts. (2.5 l)
Demand Drive Fluid Capacity	9 oz. (265 ml)
Transmission Oil Capacity	32 oz. (948 ml)
Front Rack/Storage Box Capacity	5 Gal. (18.9 l)
Rear Rack Capacity	180 lbs. (81.6 kg)
Receiver Hitch Tongue Capacity	120 lbs. (55 kg)* *Rear rack capacity and tongue weight not to exceed 180 lbs./81.6 kg
Hitch Towing Rating	1350 lbs. (612 kg)
Overall Length	83 in. (211 cm)
Overall Width	48 in. (122 cm)
Overall Height	48 in. (122 cm)
Wheelbase	50.5 in. (128.3 cm)
Ground Clearance	11.5 in. (29.2 cm)
Minimum Turning Radius	65 in. (165 cm) unloaded
Engine	Dual overhead cam, 4 valve 4 stroke single cylinder
Displacement	567 cc
Bore x Stroke	99mm x 73.6mm
Alternator Output	660 W @ 5000 RPM
Compression Ratio	10:1
Starting System	Electric
Ignition System	ECU

SPORTSMAN 570 HUNT EDITION	
Idle RPM	1200 +/- 50
Spark Plug Type / Gap	MR7F / 0.7-0.8 mm
Lubrication System	Wet Sump
Driving System Type	Automatic PVT (POLARIS Variable Transmission)
Front Suspension	Sealed MacPherson MacPherson Ride® strut with 8.9 in. (22.6 cm) travel
Rear Suspension	Sealed Dual A-Arm, IRS 9.5" (24 cm) Travel
Transmission	H/L/N/R/P
Gear Reduction, Low	23.91:1
Gear Reduction, Reverse	21.74:1
Gear Reduction, High	11.12:1
Drive Ratio, Front	3.82:1
Tires/Pressure, Front	26x8-14 / 7 psi (48.3 kPa)
Tires/Pressure, Rear	26x11-14 / 7 psi (48.3 kPa)
Brakes, Front/Rear	Single-Control Hydraulic Disc
Brakes, Auxiliary	Foot-Activated Hydraulic Disc
Brake, Parking	Hydraulic lock, all wheel
Headlight	1 Single Beam on Headlight Pod (50 watt) 2 Single Beam on Bumper (55 watt)
Brakelight / Taillights	Dual LED Brakelights (8.26 watts) / Taillights (26.9 watts)
Instrument Cluster	LCD

CLUTCHING CHART

CLUTCH SETTINGS				
ALTITUDE meters (feet)	DRIVE CLUTCH		DRIVEN CLUTCH	
	Shift Weight	Clutch Spring	Clutch Spring	Driven Helix*
0-1800 (0-6000)	EBS: 1323850 (36-67)	EBS: 7045660	EBS: 7045554	EBS: 1323720
	Non-EBS: 5632409 (25-52)	Non-EBS: 7043594	Non-EBS: 7041782	Non-EBS: 5132344
1800-3700 (6000- 12000)	EBS: 1327125 (36-63)	EBS: 7045660	EBS: 7045554	EBS: 1323720
	Non-EBS: 5633217 (25-48)	Non-EBS: 7043594	Non-EBS: 3234451	Non-EBS: 5132344
*EBS models require no helix / spring adjustment.				

TROUBLESHOOTING

DIAGNOSTIC DISPLAY CODE DEFINITIONS

Open Load: There is a break in the wires that lead to the item listed in the chart (injector, fuel pump, etc.), or the item has failed.

Short-to-Ground: The wire is shorted to ground between the electronic control unit and the item listed in the chart.

Shorted Load: The wires leading to the item listed in the chart are shorted together, or the item has shorted internally.

Short-to-Battery: The wire leading from the item listed in the chart to the electronic control unit is shorted to a wire at battery voltage.

DIAGNOSTIC CODES			
COMPONENT	CONDITION	SPN	FMI
Throttle Position Sensor	Voltage Too High	51	3
	Voltage Too Low	51	4
Engine Temperature Sensor	Voltage Too High	110	3
	Voltage Too Low	110	4
	Temperature Too High	110	16
	Engine Overheat Shutdown	110	0
Intake Air Temperature Sensor	Voltage Too High	105	3
	Voltage Too Low	105	4
Manifold Absolute Pressure Sensor	Voltage Too High	102	3
	Voltage Too Low	102	4
	Signal Out of Range	102	2
Crankshaft Position Sensor	Circuit Fault	636	8
	Plausibility Fault	636	2
Vehicle Speed Signal	Speed Too High	84	8
	Plausibility Fault	84	2



DIAGNOSTIC CODES			
COMPONENT	CONDITION	SPN	FMI
Gear Sensor Signal	Voltage Too Low	523	4
	Voltage Too Low	523	3
	Signal Fault	523	2
Injector 1 (MAG) (SDI Part Load)	Driver Circuit Open/Grounded	651	5
	Driver Circuit Short to B+	651	3
	Driver Circuit Grounded	651	4
Injector 2 (PTO) (SDI Part Load)	Driver Circuit Open/Grounded	652	5
	Driver Circuit Short to B+	652	3
	Driver Circuit Grounded	652	4
Ignition Coil Primary Driver 1 (MAG)	Driver Circuit Short to B+	1268	3
Ignition Coil Primary Driver 2 (PTO)	Driver Circuit Short to B+	1269	3
Fuel Pump Driver Circuit	Driver Circuit Open/Grounded	1347	5
	Driver Circuit Short to B+	1347	3
	Driver Circuit Grounded	1347	4
Fan Relay Driver Circuit	Driver Circuit Open/Grounded	1071	5
	Driver Circuit Short to B+	1071	3
	Driver Circuit Grounded	1071	4

DIAGNOSTIC CODES			
COMPONENT	CONDITION	SPN	FMI
Idle Air Control	Driver Circuit Open/Grounded	634	5
	Driver Circuit Short to B+	634	3
	Driver Circuit Grounded	634	4
	Position Out of Range	634	7
Starter Enable Circuit	Driver Circuit Open/Grounded	1321	5
	Driver Circuit Short to B+	1321	3
	Driver Circuit Grounded	1321	4
Chassis Relay	Driver Circuit Open/Grounded	520208	5
	Driver Circuit Short to B+	520208	3
	Driver Circuit Grounded	520208	4
All Wheel Drive Control	Driver Circuit Open/Grounded	520207	5
	Driver Circuit Short to B+	520207	3
	Driver Circuit Grounded	520207	4
System Power	Voltage Too High	168	3
	Voltage Too Low	168	4
Throttle Safety Signal	Voltage Too High	520194	3
	Voltage Too Low	520194	4
	Signal Out of Range	520194	2

DIAGNOSTIC CODES			
COMPONENT	CONDITION	SPN	FMI
	Throttle Stuck	520194	7
Active Descent Control System	Driver Circuit Open/Grounded	520203	5
	Driver Circuit Short to B+	520203	3
	Driver Circuit Grounded	520203	4
Idle Speed	Speed Too High	520211	3
	Speed Too Low	520211	4

DIAGNOSTIC CODES			
COMPONENT	CONDITION	SPN	FMI
EPS MODELS ONLY			
Vehicle Speed Sensor	Received Network Data In Error	84	19
System Power	Voltage Above Normal, Or Shorted To High Source	168	3
	Voltage Below Normal, Or Shorted To Low Source	168	4
Engine Speed	Received Network Data In Error	190	19
ECU Memory	Bad Intelligent Device Or Component	628	12
Calibration	Out Of Calibration	630	13
Steering Over Current Shut Down	Current Above Normal Or Grounded Circuit	520221	6
Steering Excessive Current Error	Current Above Normal Or Grounded Circuit	520222	6

DIAGNOSTIC CODES			
COMPONENT	CONDITION	SPN	FMI
EPS MODELS ONLY			
Steering Torque Full Failure	Condition Exists	520224	31
EPAS Inverter Temperature	Data Valid But Above Normal Operational Range - Most Severe Level	520225	0
	Data Valid But Above Normal Operating Range - Moderately Severe Level	520225	16
EPAS Communications Receive Data Error	Data Erratic, Intermittent Or Incorrect	520226	2
Position Encoder Error	Root Cause Not Known	520228	11
EPAS Software Error	Bad Intelligent Device Or Component	520229	12
EPAS Power Save Condition	Condition Exists	520231	31
EPS CAN Communications Transmit Error	Data Erratic, Intermittent Or Incorrect	520227	2

DRIVE BELT WEAR/BURN

Driving onto a pickup or tall trailer in high range

- Use low range during loading.

Starting out going up a steep incline

- Use low range

Driving at low RPM or ground speed (3-7 MPH)

- Drive at a higher speed or use low range more frequently

Insufficient warm-up at low ambient temperatures

- Warm the engine at least 5 minutes. With the transmission in neutral, advance the throttle to about 1/8 throttle in short bursts, 5 to 7 times. The belt will become more flexible and prevent belt burning.

Slow/easy clutch engagement

- Use the throttle quickly and effectively.

Towing/pushing at low RPM/ low ground speed

- Use low range only.

Utility use/plowing

- Use low range only.

Stuck in mud or snow

- Shift the transmission to low range and carefully use fast, aggressive throttle application to engage clutch.
- **WARNING:** Excessive throttle may cause loss of control and vehicle rollover.

Climbing over large objects from a stopped position

- Shift the transmission to low range and carefully use fast, brief, aggressive throttle application to engage clutch.
- **WARNING:** Excessive throttle may cause loss of control and vehicle rollover.

Belt slippage from water or snow ingestion into the PVT system

- Dry out the PVT. Prevent water from entering the PVT intake duct. See Intake Pre-Filters for more information. Inspect clutch seals for damage if repeated leaking occurs.

Clutch malfunction

- An authorized dealer can assist.

Poor engine performance

- Check for fouled plug or foreign material in gas tank or fuel lines. An authorized dealer can assist.

Slippage from failure to warm up belt

- Always warm up the belt by operating below 30 mph for one mile (5 miles or more when temperature is below freezing).

Wrong or missing belt

- Install the recommended belt.

Improper break-in

- Always break in a new belt and/or clutch.

ENGINE DOESN'T TURN OVER

Low battery voltage

- Recharge the battery

Loose battery connections

- Check all connections and tighten

Loose solenoid connections

- Check all connections and tighten

Loose electronic control box connections

- Inspect, clean, reinstall connectors

ENGINE TURNS OVER, FAILS TO START

Out of fuel

- Refuel

Water is present in fuel

- Drain the fuel system and refuel

Old or non-recommended fuel

- Replace with fresh recommended fuel

Fouled or defective spark plug

- Inspect plug and replace if necessary

No spark to spark plug

- Inspect plug and replace if necessary

Water or fuel in crankcase

- Your authorized dealer can assist

Low battery voltage

- Recharge the battery to 12.8 VDC

Mechanical failure

- Your authorized dealer can assist

ENGINE BACKFIRES

Weak spark from spark plug

- Inspect, clean and/or replace spark plug

Incorrect spark plug gap or heat range

- Set gap to specs or replace plug

Old or non-recommended fuel

- Replace with fresh recommended fuel

Incorrectly installed spark plug wires

- Your authorized dealer can assist

Mechanical failure

- Your authorized dealer can assist

Loose ignition connections

- Check all connections and tighten

Water present in fuel

- Replace with fresh recommended fuel

ENGINE PINGS OR KNOCKS

Poor quality or low octane fuel

- Replace with recommended fuel

Incorrect spark plug gap or heat range

- Set gap to specs or replace plug

ENGINE RUNS IRREGULARLY, STALLS OR MISFIRES

Fouled or defective spark plug

- Inspect, clean and/or replace spark plug

Worn or defective spark plug wires

- Your authorized dealer can assist

Incorrect spark plug gap or heat range

- Set gap to specs or replace plug

Loose ignition connections

- Check all connections and tighten

Water present in fuel

- Replace with new fuel

Low battery voltage

- Recharge battery to 12.8 VDC

Incorrect fuel

- Replace with recommended fuel

Clogged air filter

- Inspect and clean or replace

Clogged intake pre-filter

- Inspect and clean (with soapy water) or replace

Other mechanical failure

- Your authorized dealer can assist

ENGINE STOPS OR LOSES POWER

Out of fuel

- Refuel

Kinked or plugged fuel vent line

- Inspect and replace

Water is present in fuel

- Replace with new fuel

Fouled or defective spark plug

- Inspect, clean and/or replace spark plug

Worn or defective spark plug wires

- Your authorized dealer can assist

Incorrect spark plug gap or heat range

- Set gap to specs or replace plug

Loose ignition connections

- Check all connections and tighten

Low battery voltage

- Recharge the battery

Incorrect fuel

- Replace with fresh recommended fuel

Clogged air filter

- Inspect and clean or replace

Clogged intake pre-filter

- Inspect and clean (with soapy water) or replace

Other mechanical failure

- Your authorized dealer can assist

Overheated engine

- Clean radiator screen and core, clean engine exterior, and check coolant level. Your dealer can assist.

Warning

This content is compiled from multiple sources and is provided for reference purposes only. It may not be complete or fully applicable to all situations. If you are unable to resolve your issue, please contact the product manufacturer or an authorized service provider for official support.