

## Installation

The docking station must be plugged in and turned on at all times.

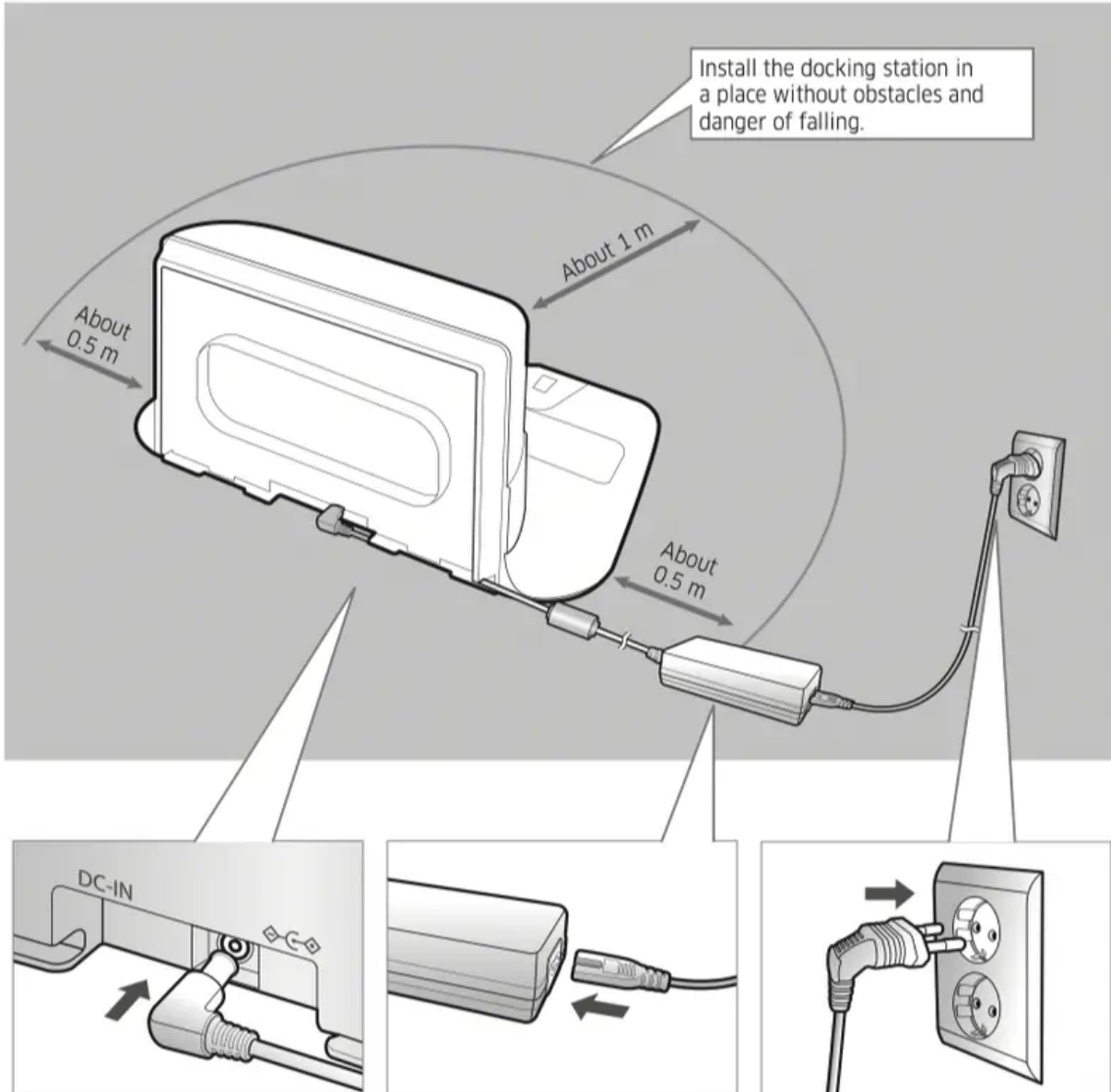







**1. Connect the battery charger jack to the docking station**

**2. Connect the power cord to the battery charger**

When using the battery charger, the side with the sticker attached must face down.

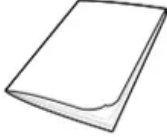
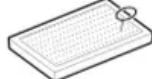
**3. Connect the power plug to the outlet**

## Accessories

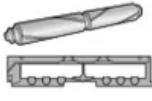
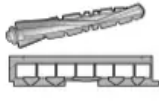
				
Remote controller	Batteries (AAA type)	User manual	Spare filter	Docking station
				
Power cord	Battery charger	Boundary markers	Soft Action Brush / Brush cover	Combo Brush / Brush cover

\*\*Accessories may differ depending on the models.

\*\*Refer to page 17 for the installation of boundary markers.

\*\*Battery Spec : Lithium-ion, 21.6V, 3600mAh, 12cell

\*\*For VR2A726\*\*\* models, combo brush and soft action brush are provided.

## Installation note

### Note

- Install the docking station in a place where the floor and wall are level.
  - It is best to install the docking station along the grain of wooden floors.
  - If the emergency switch is off, the POWERbot will not charge even if it is docked on the docking station.
  - Always turn on the power of the docking station.
- If power is not supplied to the docking station, the POWERbot cannot find it and cannot automatically recharge.
- If the POWERbot is left detached from the docking station, the battery will drain naturally.
- If the POWERbot is in sleep mode, power will not come on even if the emergency switch is turned off and then on. Press and hold the [Start/Stop] button on the POWERbot to turn the sleep mode off.

## Charging

Charge the POWERbot fully before using for the first time. (Refer to the page 35 for the charging time.)

## WARNING

- Rated input voltage of this product is 100-240 V ~ .

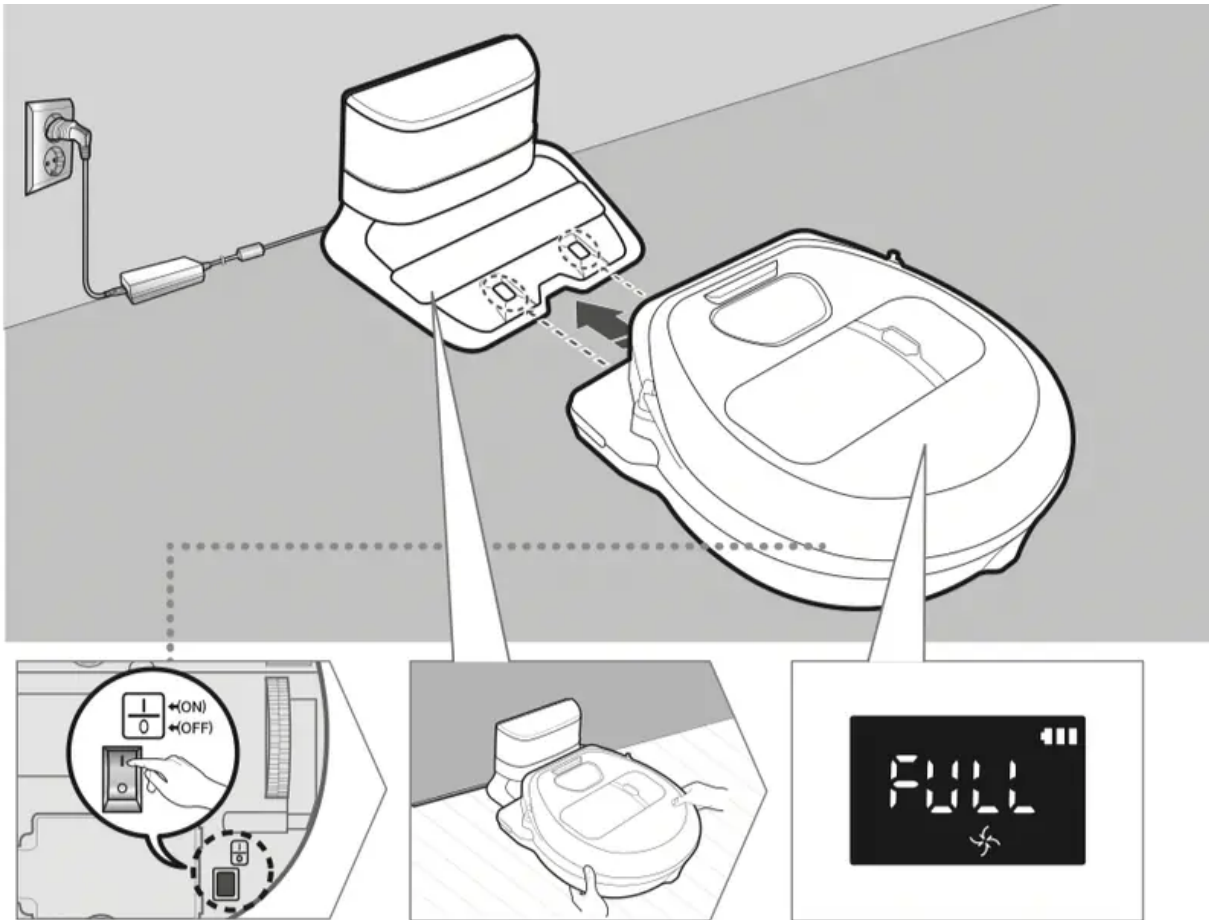

### 1. Turn on the emergency switch on the bottom

You must turn on the emergency switch to turn on the POWERbot.

### 2. Manually charge the POWERbot by placing it on the docking station

Make sure the charging pins on the POWERbot and the docking station are aligned.

### 3. Check the charging status

"**0000**" will turn on according to charging progress and "FULL" will turn on when charging is complete.

## Automatic charging

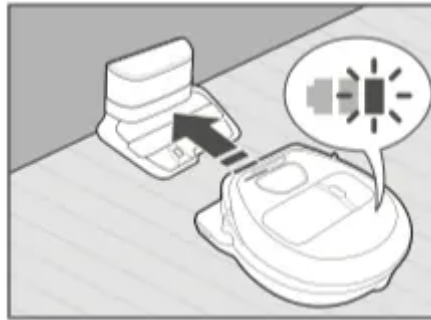

When the battery indicator blinks during cleaning, the POWERbot will return to the docking station to charge itself automatically.

## Recharging

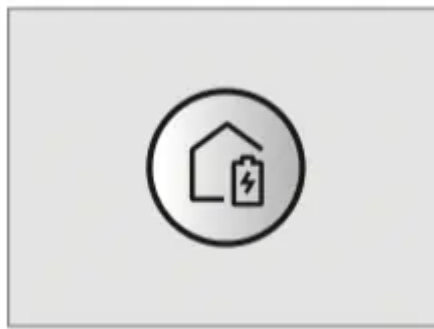

You can command the POWERbot to recharge at the docking station while it is in cleaning.

## Low battery (Lo)

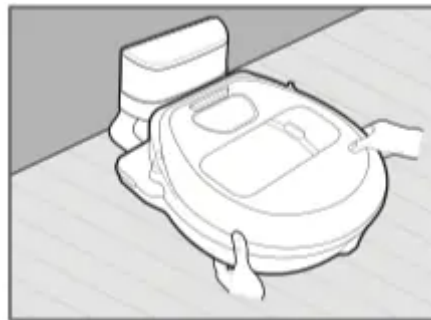

Manually charge the POWERbot by placing it on the docking station.

### Steps to take if recharging not occurring:

#### Check the installation status of the docking station when:

- the docking station is located in a place where the POWERbot cannot easily access it.
  - the distance between the docking station and POWERbot is over 16.4 ft (5 m).
- It may take a long time for POWERbot to return to the docking station for recharging

### Manually charge the POWERbot when:

- the docking station is located in a corner
- the battery is fully exhausted fthe POWERbot is immobilized by an obstacle (furniture etc.)
- the POWERbot can't climb a threshold near
- the docking station (The maximum height of a threshold the POWERbot can climb is about 0.6 in (1.5 cm)).
- when the battery indicator blinks and "Lo" is displayed
- when the POWERbot is set to the Spot clean or Manual clean mode

## Using POWERbot

You must turn on the emergency switch on the bottom of the unit before using POWERbot.

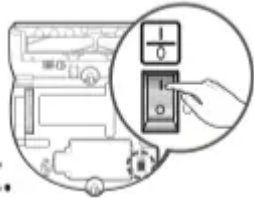

### Turning the power on/off

Press the  button for more than 3 seconds

### WARNING

- When POWERbot is not used for about 30 minutes, it automatically returns to the docking station to recharge.

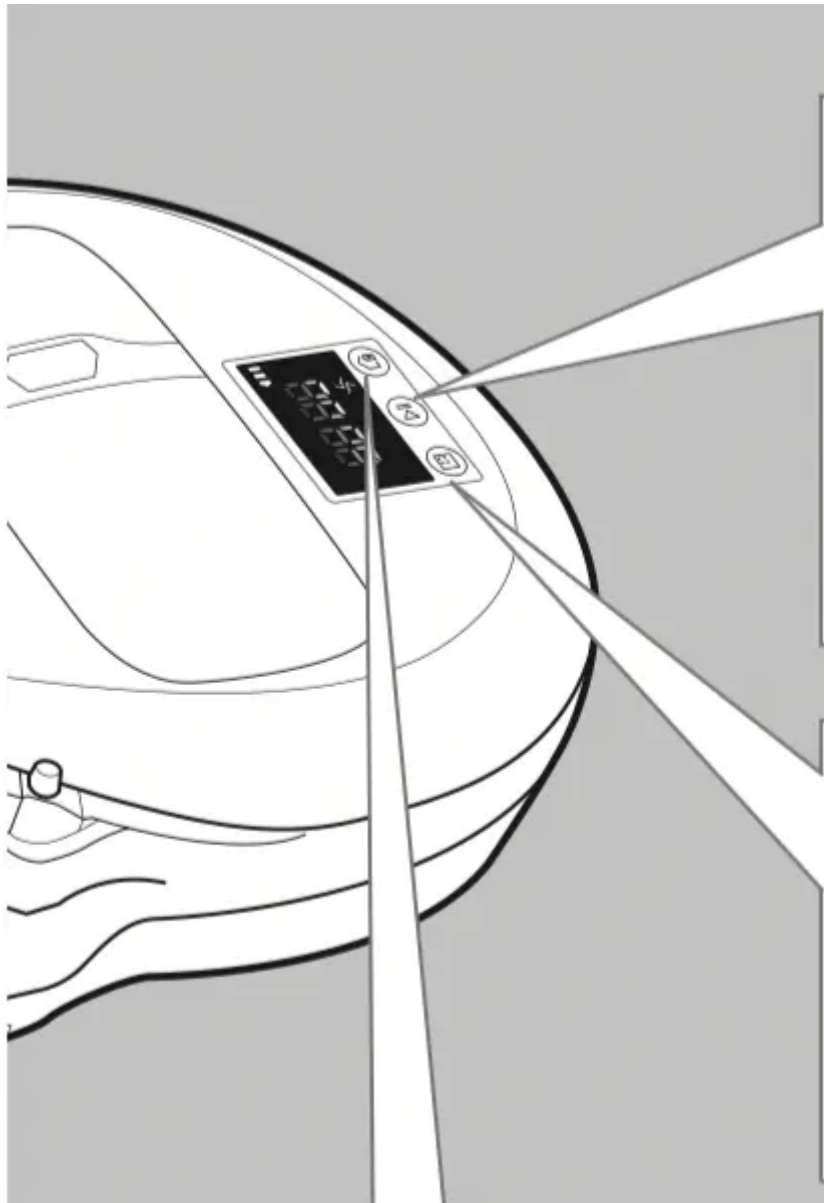

### Starting Auto clean mode

The POWERbot moves and automatically cleans the set areas only once.



\*\* Stop cleaning: Press and release the  button

### Using Spot clean mode

The POWERbot cleans a localized area intensely.



### Recharging/Energy-saving mode

- Recharging







You can command POWERbot to recharge at the docking station automatically while it is cleaning by pressing this button.

- Energy-saving mode

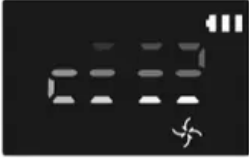
Refer to page 17.

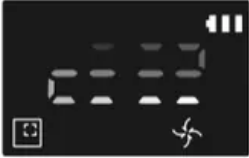

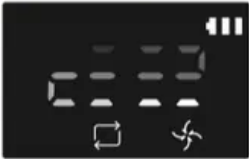
### Selecting cleaning modes

Cleaning mode	How to select	Displayed icon
Auto clean		
Spot clean		
Repeat clean	* Press the [Repeat] on the remote controller first and then press the [Start/Stop  ].	
Manual clean	* Manual clean mode can be selected by the direction control buttons of the remote controller.	

\* If POWERbot fails to return to the docking station, it will turn to energy-saving mode and display panel will be turned off.



Cleans a localized area intensely. It can be used to clean bread or cookie crumbs.

### Manual clean



You can move POWERbot with the remote controller to clean the desired spot.

### Repeat clean

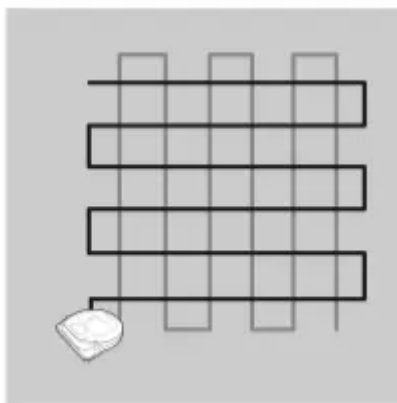



Cleans repeatedly until the battery is depleted.

### Note

- If you select Auto clean or Repeat clean, the POWERbot cleans the area near the docking station first.

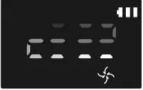
## Using special cleaning functions

Cleaning function	Operation	Displayed icon
<b>Intelligent power control</b>	*When the POWERbot detects a carpet in normal mode, it will automatically operate with stronger suction power.	
<b>Edge Clean Master</b>	* When the POWERbot detects an edge or corner in Auto clean or Spot clean, the auto shutter tool operates and approaches the edge or corner section to clean. <ul style="list-style-type: none"> <li>• Straight edge (One time cleaning)</li> <li>• Corner (Two times cleaning)</li> </ul>	

## About the boundary markers

To prevent the POWERbot from entering the following areas, place the boundary markers on the floor in an shape at intervals of about 5.9 in (15 cm).

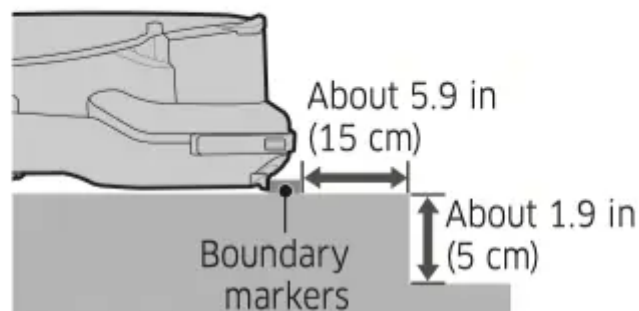

Where a raised spot exceeds 1.9 in (5 cm)

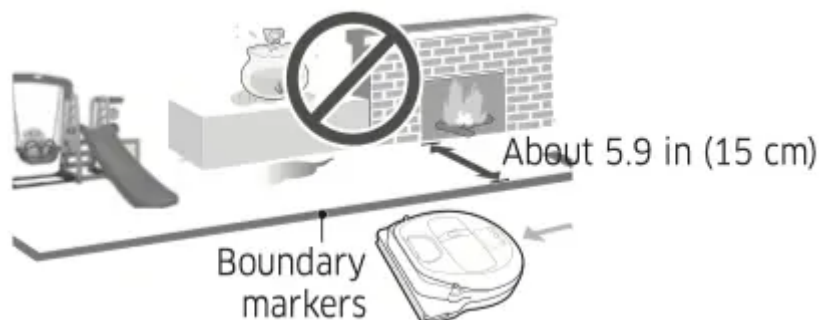

Where there is a slide, swing, fireplace, or any flammable substance or moisture.

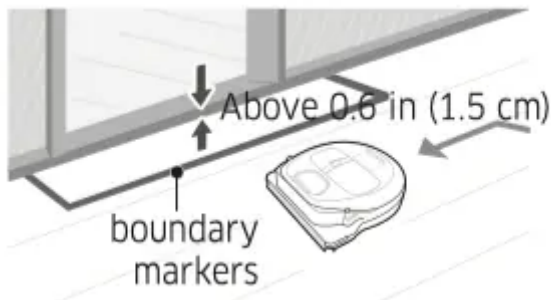

Where a threshold is higher than 0.6 in (1.5 cm)

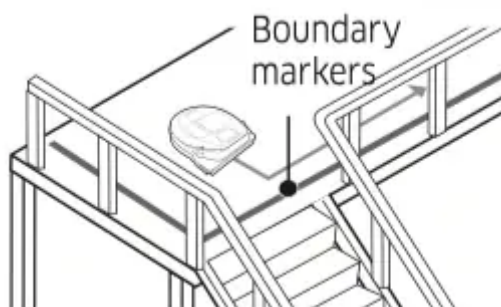

Where there is risk of falling such as near stairs, porches, or guardrails.

### Using Energy-saving mode

You can select the Energy-saving mode to save energy during battery charging. Energy-saving mode turns off all functions except battery charging. Use it to reduce power consumption while you are away from home for an extended period of time.

How to select or cancel	Displayed icon
 <p>Press for 5 sec.</p>	 <p><b>**About 3 seconds later, the previous indicator will appear.</b></p>

### Note

- If you select the Auto/Max/Manual clean mode or press the Point cleaning button, the Energy-saving mode will be cancelled.
- When Energy-saving mode is on, setting the schedule will cancel Energy-saving mode.



– If you select the Energy-saving mode after setting the schedule, the schedule will not be cancelled.



- If the docking station is off, Energy-saving mode will be cancelled.
- If the battery is completely flat, place the POWERbot on the docking station, and then

press the [Start/Stop ] button on the main body.

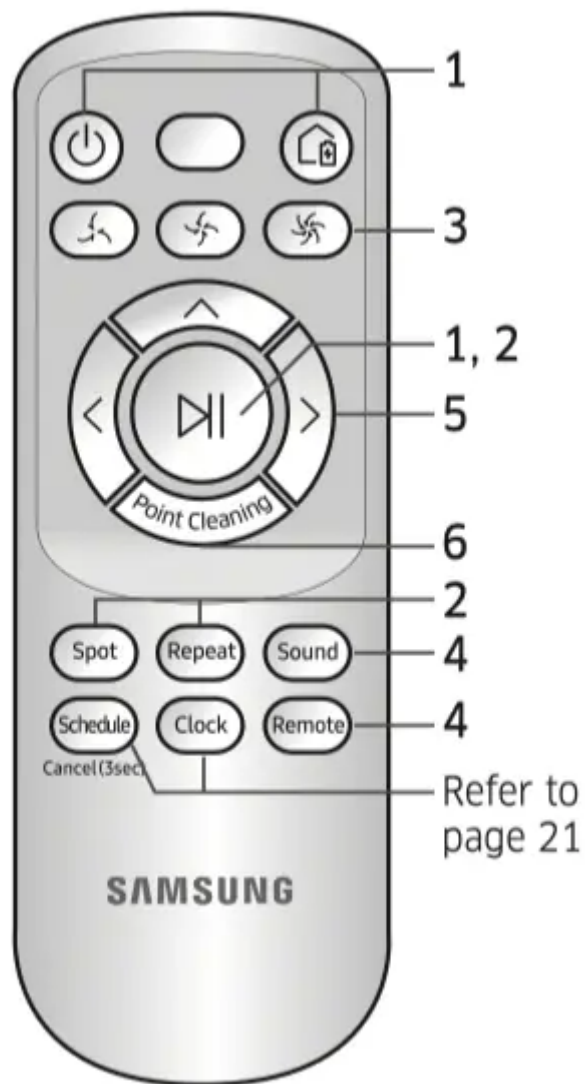

## Using the remote controller





### 1. Operation & Recharging

<b>Power</b>		Turn POWERbot's power on/off
<b>Recharging</b>		Select to recharge POWERbot at the docking station automatically
<b>Start/Stop</b>		Select to start or stop cleaning process



## 2. Cleaning modes

<b>Auto clean</b>		Select to clean all set areas only once and then automatically return to the docking station.
<b>Spot clean</b>		Select to clean a localized area intensely
<b>Repeat clean</b>		Select to clean repeatedly until the battery becomes very low with indicator blinking

## 3. Suction power



<b>Turbo mode</b>		Select to clean with the strongest suction power
<b>Normal mode</b>		Select to clean with moderate suction power
<b>Quiet mode</b>		Select to clean with lower operation noise

## 4. Additional function

<b>Sound</b>		Select to set the voice guide ▶ Voice Guide (English) → Sound Effects → Mute ▶ Press and hold the sound button to change and set a language.
<b>Remote control</b>		Select to turn Wi-Fi function on or off

\*\*Turning the emergency switch off and then on will not cancel or change the settings.

### 5. Manual clean mode & Direction control

<b>Move forward</b>		Select to move forward
<b>Turn left</b>		Select to turn left
<b>Turn right</b>		Select to turn right

\*\*Moving backward is not available.

### 6. Point cleaning

You can use the remote controller to point and clean the desired spot while the POWERbot is in cleaning process.

Point the red light on the floor within 0.5 m around POWERbot's location.

Press and hold the Point cleaning button to move the red light to the desired spot. The POWERbot will follow the light while cleaning.

- If you point the red light directly at the body of the POWERbot, abnormal operation may occur. Therefore, point the red light within 0.5 m around the POWERbot.

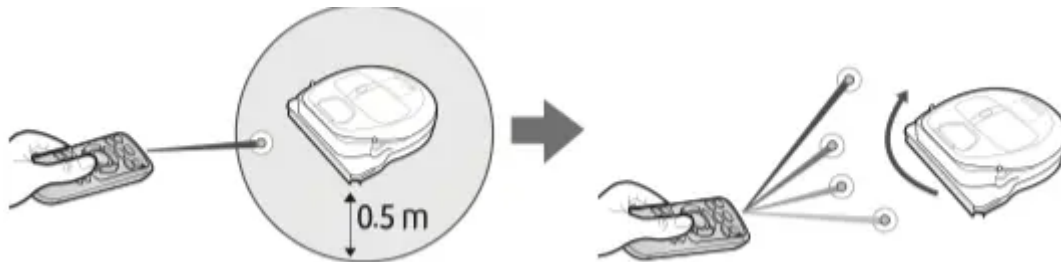

### Operating distance of the remote controller

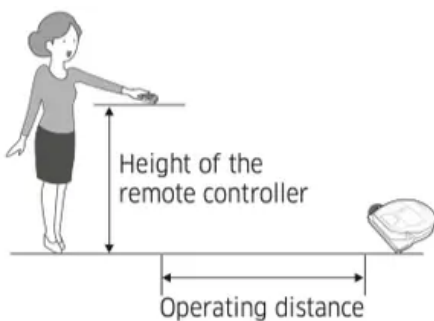

<b>Height of the remote controller</b>	1.6 ft (0.5 m)	3.3 ft (1 m)	4.9 ft (1.5 m)
<b>Operating distance</b>	About 4.9 ft (1.5 m)	About 6.6 ft (2 m)	About 9.8 ft (3 m)

### Inserting batteries

Open the battery cover by lifting it up while pressing the locking tab and insert the batteries as shown in the illustration. Then, close the cover until it clicks into place.



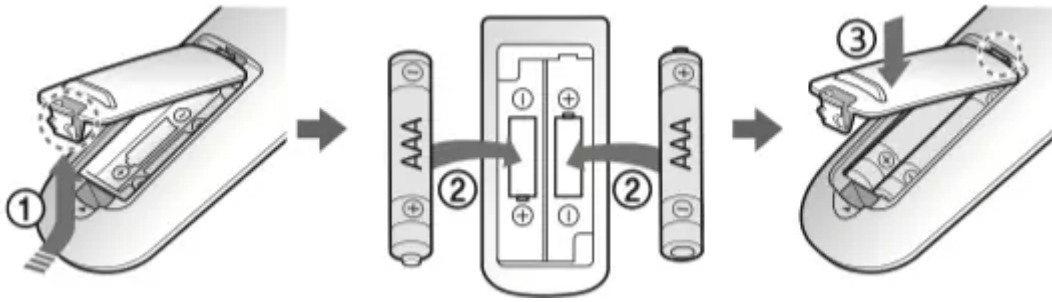

### Name of each part

Top

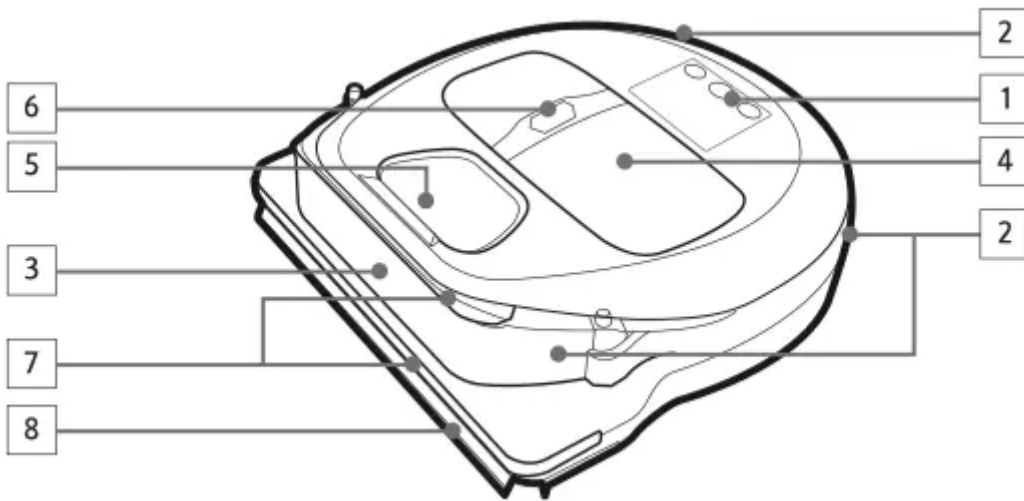

1. Display panel
2. Remote control signal receiver
3. Obstacle sensor
4. Dustbin
5. Camera
6. Dustbin button
7. Bumper sensor
8. Auto shutter tool

## Bottom

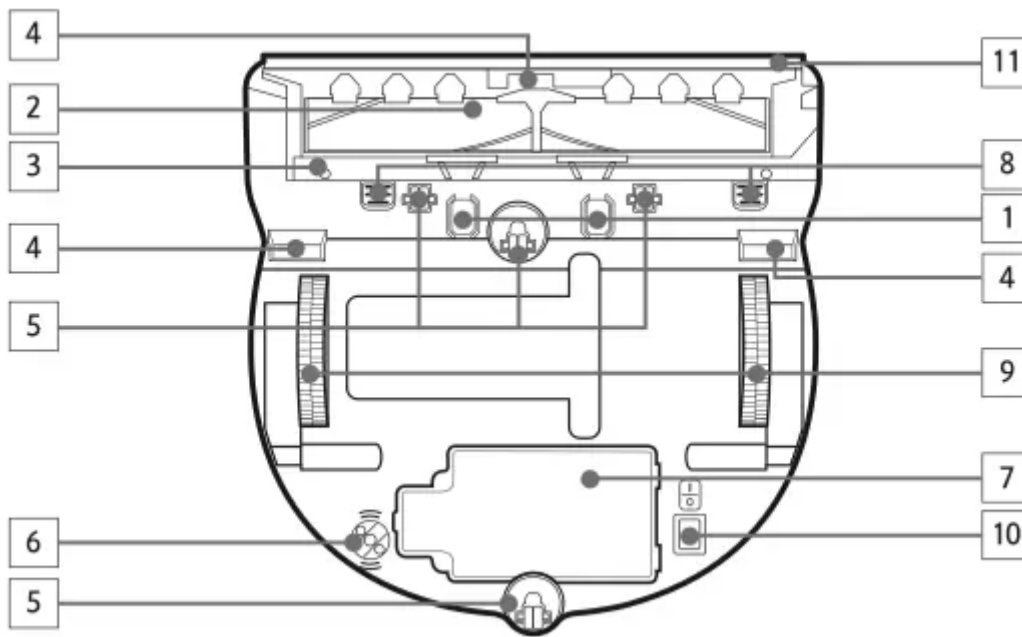

\* Optical sensor: Measures moving distance by the light pattern which is reflected from floors and comes into the optical receiver.

1. Charge pins
2. Brush
3. Brush cover
4. Cliff sensor
5. Roller
6. \* Optical sensor
7. Battery cover
8. Brush cover button
9. Driving wheel
10. Emergency switch
11. Auto shutter tool

## Display panel

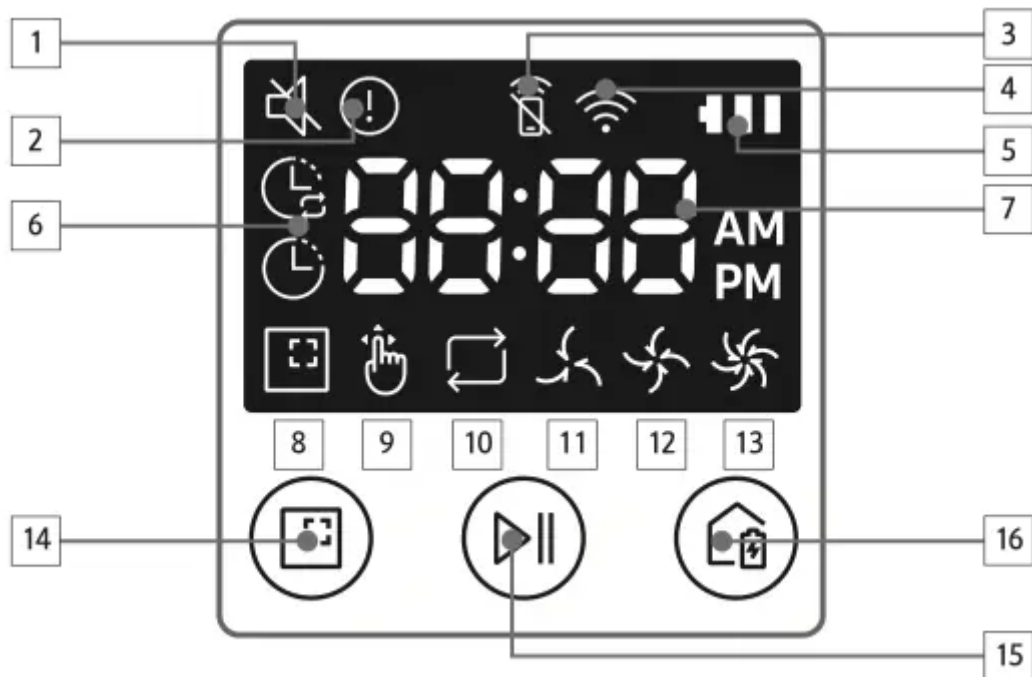

1. Mute
2. Information Indicator
3. Remote control Off/On indicator
4. Wi-Fi
5. Battery indicator
6. One-time/Daily schedule
7. Number display
8. Spot clean mode
9. Manual clean mode
10. Repeat clean mode
11. Quiet mode
12. Normal mode
13. Turbo mode
14. Spot cleaning button
15. Start/Stop button
16. Recharging button

## Setting time/schedule

### Setting the time

You must set the current time before using the One-time/daily schedule.

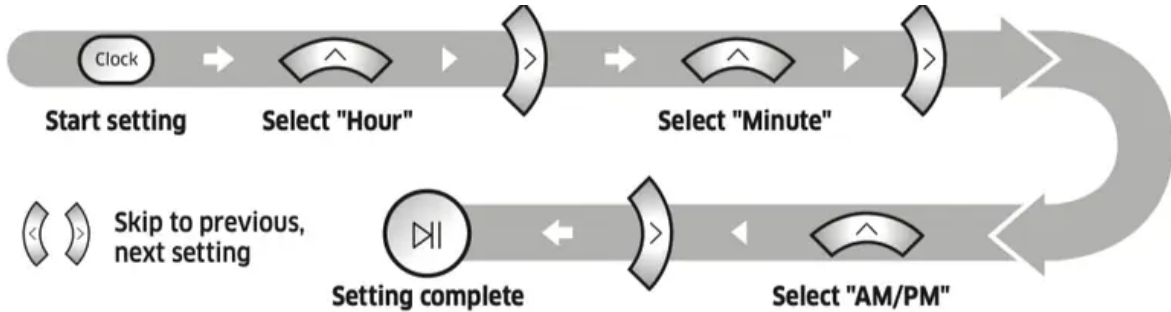

### Setting the schedule

Setting/cancelling the schedule can only be done while POWERbot is docked on the docking station.

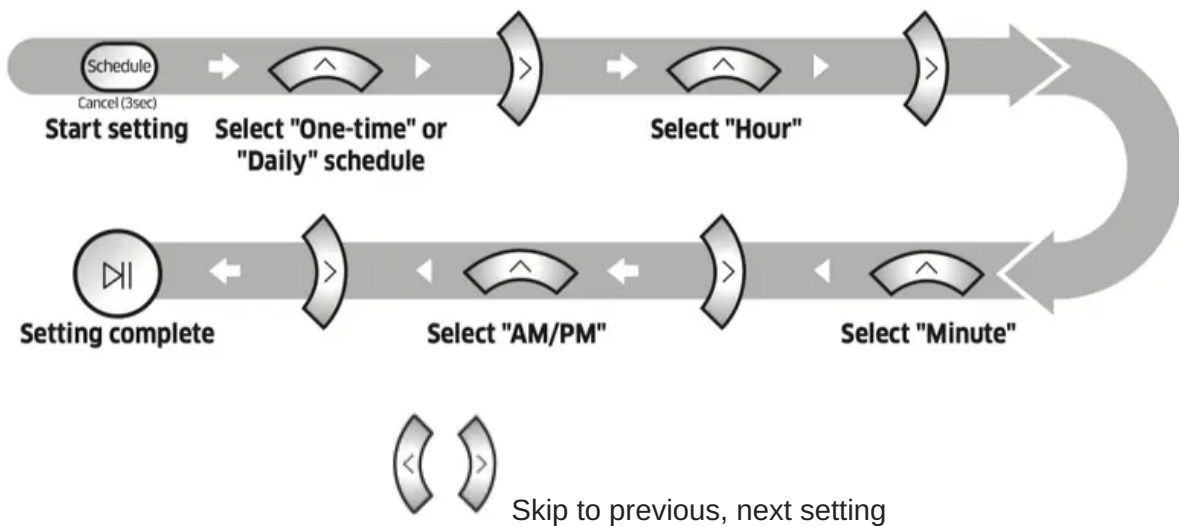



### Cancelling during setup

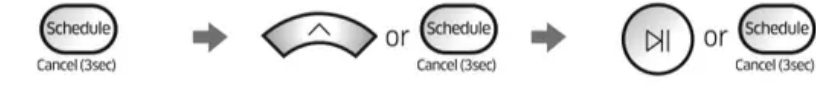

Setting will be canceled automatically when there's no input for 7 seconds.

### Cancelling One-time/Daily schedule

<p><b>When both One-time/ Daily schedule is set</b></p>	 <p>Press for 3 sec.      Select the schedule      Cancel complete</p>
<p><b>When either one of One-time or Daily schedule is set</b></p>	 <p>Press for 3 sec.</p>

- You can set the multi-time schedule and the anti-disturbance time with the SmartThings App.
  - When the anti-disturbance time is set at the SmartThings App, you cannot set the schedule at the body of the POWERbot within the set anti-disturbance time.
- If you want to set the schedule within the set anti-disturbance time, cancel the set anti-disturbance time at the SmartThings App first.

## Cleaning and maintaining

You must turn off the emergency switch before cleaning POWERbot.

### Cleaning the dustbin

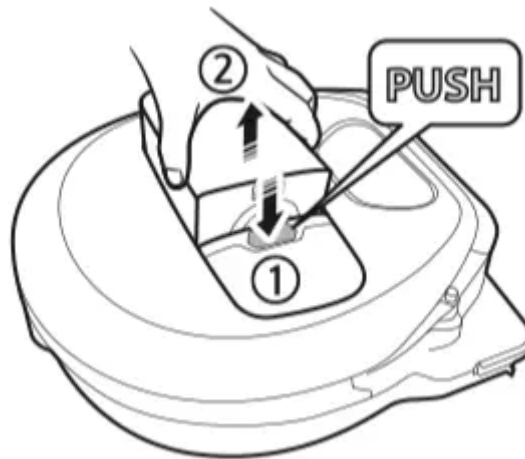

1. Press the button to remove the dustbin

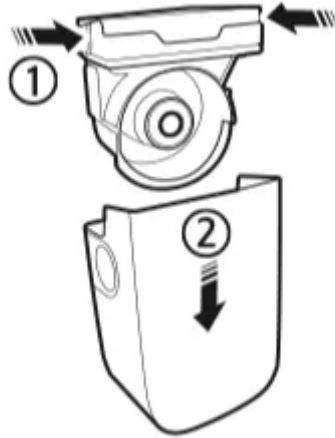

2. Remove the dustbin cover



3. Remove dust in the dustbin and cyclone unit



4. Detach the cyclone unit from the dustbin cover, and then wash the dustbin and the filter

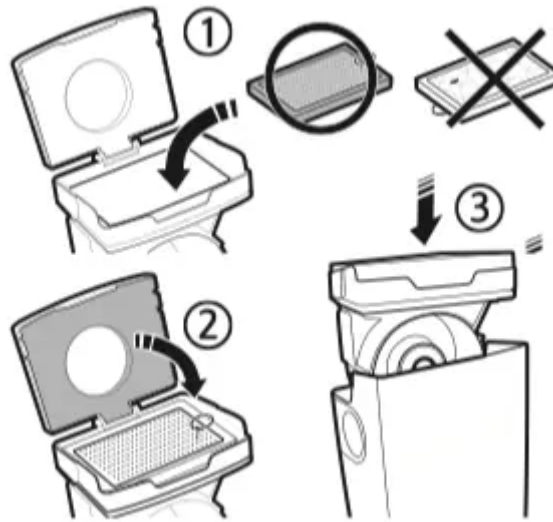

5. Reassemble the dustbin



6. Reinsert the dustbin into the main body until it clicks

### Cleaning the sensors and the camera

Lightly wipe with soft cloth. Do not use water or cleaning solutions.

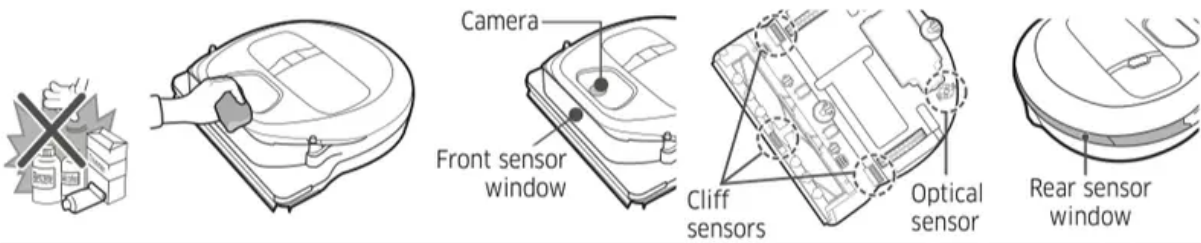

### Cleaning the brush and Auto shutter tool

Brush design may differ depending on the model. Do not clean the brush with water.

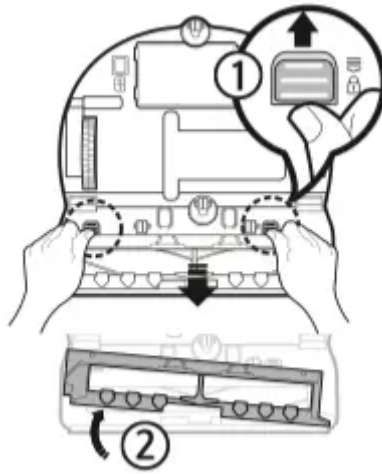

1. Remove the brush cover

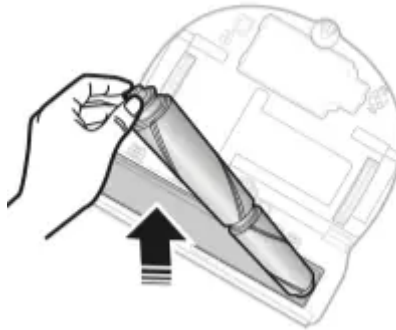

2. Remove the brush



Soft Action Brush



Combo Brush

3. Clean the brush

Remove remaining dirt on the soft action brush with a wet tissue or a dry cloth.

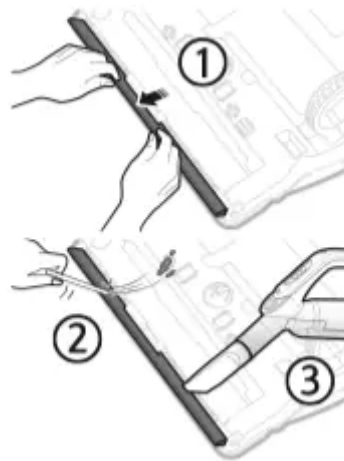

4. Clean the auto shutter tool

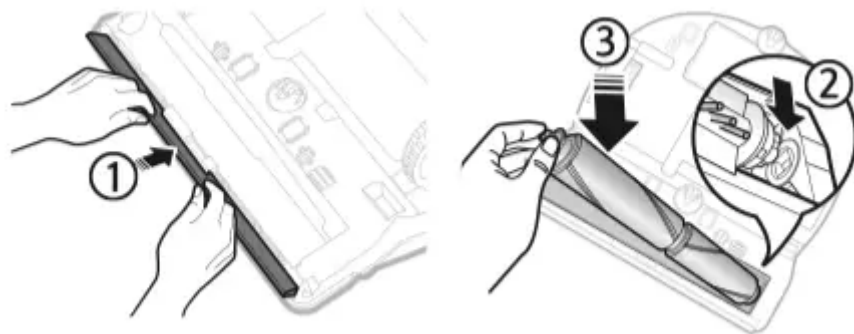

5. Reassemble the brush

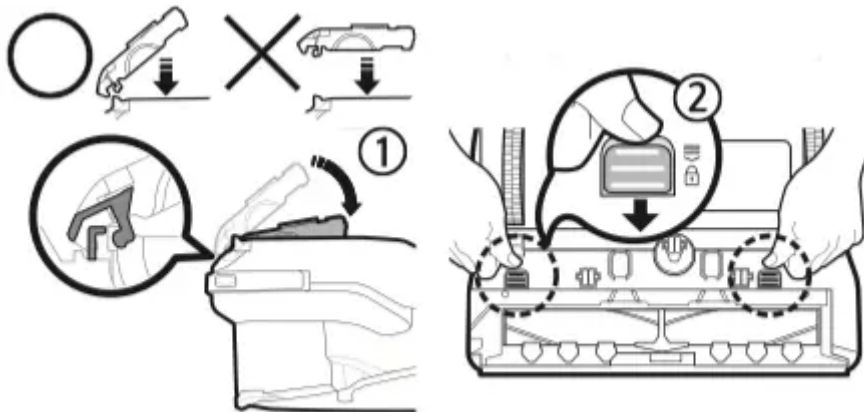

6. Reassemble the brush cover

For VR20R726\*\*\* models, check that the brush cover is correct for the assembled brush.

## Cleaning the Driving wheel

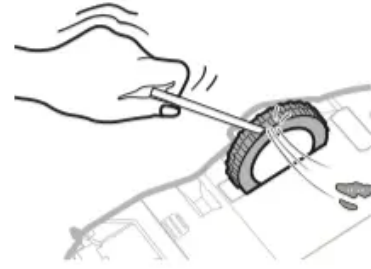
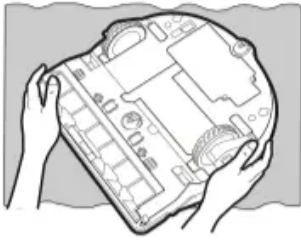

1. Put a soft cloth on the floor and place POWERbot upside-down on the cloth.
2. Use a blunt rod or tweezers to remove foreign matter.

## SmartThings App

The SmartThings App is only compatible with models that have a Wi-Fi function.

### Setting up the wireless router

Please refer to the user manual of your wireless router if you have access problems.

- Samsung POWERbot supports only Wi-Fi 2.4 Ghz.
- Samsung POWERbot supports IEEE 802.11b/g/n and Soft-AP.
  - IEEE 802.11n is recommended.
- Samsung POWERbot supports only DHCP (Dynamic Host Configuration Protocol). Please make sure that the DHCP server option is activated on your wireless router.
- POWERbot supports the WEP-OPEN, WPA-PSK/TKIP, and WPA2-PSK/AES for the authentication and encryption protocols.
  - WPA2-PSK/AES is recommended.
  - Confirm that your router has a unique SSID and password.
- The quality of your wireless network connection may be influenced by the surrounding wireless environment.
- If your Internet service provider has permanently registered the MAC address (a unique identification number) of your PC or modem, your POWERbot may not be able to connect to the Internet. Ask your Internet service provider about the procedure to connect an apparatus other than a PC to the Internet.
- If your internet service provider requires your ID or password to connect to the internet, your POWERbot may not be able to connect. If this is the case, you must enter your ID or password when connecting to the Internet.
- The POWERbot may not be able to connect to the Internet because of firewall issues. Contact your Internet service provider to resolve these issues.

- Some wireless routers may transmit an abnormal Domain Name Server (DNS) address even if the Internet is not connected. If this occurs, contact the manufacturer of your wireless router and your Internet service provider.
- If you still cannot connect to the Internet even after trying the procedure provided by your Internet service provider, please contact an authorized Samsung service center.
- If your router is not a Wi-Fi certified product, The POWERbot may not be able to connect to the Internet.

## Downloading the SmartThings App

- Download and install the SmartThings app from the markets (Google Play Store, Apple App Store, or Samsung Galaxy Apps). To find the app, use the keyword "SmartThings".

### Note

- SmartThings is incompatible with tablets and some mobile devices.
  - [Android] 6.0 or later (at least 2GB of RAM) is recommended.
  - iPad and some mobile devices may not be supported.
  - [iOS 10.0] or later / iPhone 6 or later is supported.
  - Visit Play Store or App Store to see if your mobile device is compatible with SmartThings.
  - The supported features are subject to change without any prior notice.

## Setting up a Samsung account

- You must sign in to a Samsung account before using the SmartThings app.
- To set up a Samsung account, you can follow the directions provided by the SmartThings app.
- Or, if you have a Samsung smartphone, you can add your Samsung account in the setting app of your smartphone. Then, it will automatically sign in to your Samsung account.





## Adding a device to the SmartThings APP

1. Connect your smartphone to your wireless router.
  - If the smartphone is not connected, turn on the Wi-Fi in the Settings App and select a wireless router you want to connect to.
  - Disable the "Mobile data" use option of a smartphone to use Wi-Fi only and connect a device.
2. Launch the SmartThings app on your smartphone.

3. If a pop-up saying that a new device has been found appears, tap ADD NOW.
  - If the pop-up doesn't appear, tap the + button and select the device which you want to connect from the list of AVAILABLE DEVICES.
  - If your device doesn't appear in the list, add the device manually by selecting the device type and selecting the specific device model.
4. [Android] The connection to your device will be progressed automatically.
  - [iOS] Open the setting app, and select [robot vacuum] Samsung in the Wi-Fi list.
5. Provide the authentication when you are directed to do so.
6. [Android] The connection to your wireless router will be progressed automatically.
  - [iOS] Open the setting app, and select the wireless router in the Wi-Fi list.
7. The remaining setup will be automatically done. Then, a new Device Card will be added.

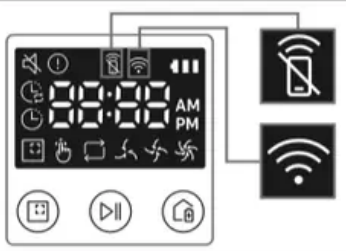
**Note**

- If you cannot complete the product registration, please take the following steps.
  - Try the registration procedure again as you have directed by the pop-up messages.
  - Confirm that the UPnP option of your wireless router is active, and then try the registration procedure again.
  - Confirm that your wireless router is operating in wireless mode, and then try the registration procedure again.
  - If you have two or more POWERbots, turn off the other POWERbots, and then try to register your POWERbot again.
  - If there is any other wireless router that has the same SSID as your wireless router, the registration might be failed.
- Remote control and Wi-Fi indicator

	On	Remote control is blocked. (The remote controller can still be allowed.)	
	Off	Remote control is allowed.	
	On	The POWERbot is connected to the wireless router.	
	Off	The POWERbot is trying to connect the wireless router.	

- When the remote control is blocked, you cannot control the POWERbot on your smartphone.
- The POWERbot and your smartphone are not connected to the same wireless router, a response delay may occur depending on your network environment.

## Software Update

- When the POWERbot is charging on the docking station, the POWERbot connects to the server and then checks if a software is available. If a new software is found, POWERbot will automatically download and update it.
- If “UP” is displayed on the display panel while the POWERbot is charging, it means that an update is in progress. Please wait for completing the update before using the POWERbot.

## Using the SmartThings APP

- When you tap the device card on the SmartThings app, the plug-in for your device will be launched.

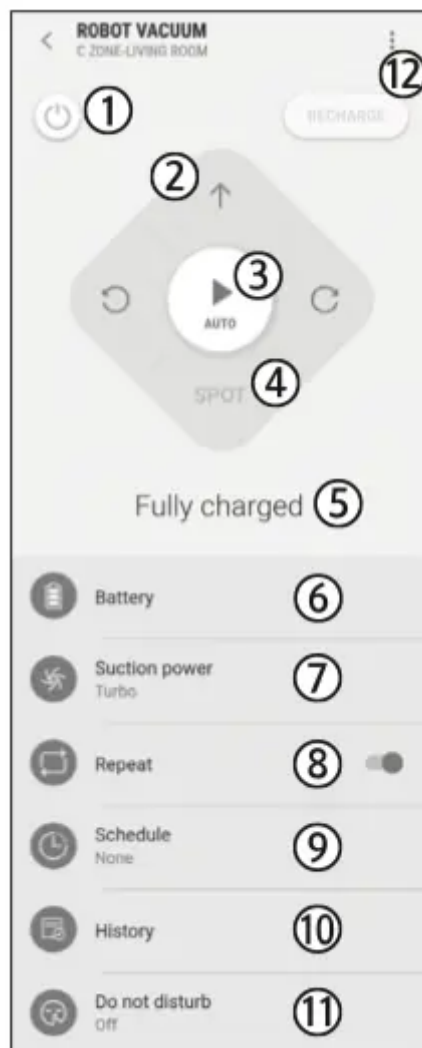

1. Power (on / off)
2. Direction controls with Manual clean mode (Forward, Left turn, Right turn)
3. Auto clean mode (start /stop)
4. Spot clean mode

5. Current status

6. Battery status

7. Suction power

8. Repeat Clean (on / off)

9. Schedule (Once / Daily / Multi-time)

– Although you can set the schedule within the anti-disturbance time which is set at the SmartThings App, the schedule function will not work.

10. Cleaning history

11. Anti-disturbance setting

– Setting is available only at SmartThings App.

12. Settings > Voice Guide

## Notes and cautions

### Charging

#### Note

- If the battery overheats during charging, it may take longer to charge.
- When automatic charging is not working, do the following:
  - Turn the emergency switch (on the bottom of POWERbot) off and on again.
  - Unplug the docking station's power plug and then plug it back on.
  - Unplug the docking station, and then check whether there is any foreign matter on the charge pins and clean POWERbot and the charge pins of the docking station with a dry cloth or rag.
  - Check for any obstacles such as reflective objects, chairs, etc. near the docking station.
    - If POWERbot is left detached from the docking station, the battery will drain naturally.
  - Try to keep POWERbot being charged on the docking station. (However, turn off the emergency switch and leave the docking station unplugged when planning to leave the house for long periods of time by going on a business trip or vacation, etc.)

### Using

#### Note

- The POWERbot may get caught on thresholds, etc. during cleaning.

- To restart operation, shut off the emergency switch, move the POWERbot to an area where it can move easily, and then turn on the power again.
  - The POWERbot cannot completely clean areas it cannot enter, such as corners, between the wall and sofa, etc.
- Please use another cleaning tool to clean them regularly.
  - The POWERbot cannot vacuum clumps of dirt, so some may remain on the floor after cleaning.
- Please use another cleaning tool to clean them regularly.
  - If POWERbot is turned off, you cannot turn it on by pressing the Power button on the remote controller. Press and hold the [Start/Stop] button on POWERbot.
  - You cannot select and have the POWERbot execute Spot clean mode while it is charging.
  - If you press Manual clean / Point cleaning button while charging, the POWERbot will be detached from the docking station and then turn into the standby mode.

## Cleaning and maintenance

### Note

- If you washed the dustbin and filter with water
  - Dustbin: Completely wipe out the water.
  - Filter: Completely dry it in the shade before using.
    - When cleaning the auto shutter tool, do not pull the auto shutter tool out too hard.

### Caution

- Watch your fingers when attaching or detaching the filter, since they may get stuck in the dustbin's intake.
- To avoid blockages by foreign matter, do not let the POWERbot vacuum up toothpicks, cotton swabs etc.
- If it is difficult to remove foreign matter from the brush, contact an authorized Samsung service center.
- Since the brush removes dirt from the floor during cleaning, foreign matter such as thread, long hair, etc. may get caught in it. For the best cleaning results, check and clean it regularly.
- If a brush or brush cover is not assembled correctly after the maintenance work, scratches may occur on the floor, or product malfunction may occur. Therefore, assemble them correctly by checking the maintenance method.

## Information codes

1. The information code below appears with a voice guide
2. Turn off the emergency switch and check the below instructions and take appropriate action
3. Information code will disappear when you turn on the emergency switch

Information codes	Checklist
	<p><b>The POWERbot is caught, stuck or trapped while moving around.</b></p> <ul style="list-style-type: none"> <li>• Turn off the emergency switch and move the POWERbot to another area.</li> </ul>
C 01	<p><b>Foreign matter caught in the brush.</b></p> <ul style="list-style-type: none"> <li>• Turn off the emergency switch and remove the foreign matter from the brush.</li> </ul>
C 02	<p><b>Foreign matter caught in the left Driving wheel.</b></p> <ul style="list-style-type: none"> <li>• Turn off the emergency switch and remove the foreign matter from the Driving wheel.</li> </ul>
C 03	<p><b>Foreign matter caught in the right Driving wheel.</b></p> <ul style="list-style-type: none"> <li>• Turn off the emergency switch and remove the foreign matter from the Driving wheel.</li> </ul>
C 05	<p><b>Bumper sensor needs to be checked.</b></p> <ul style="list-style-type: none"> <li>• Turn off the emergency switch and turn it back on.</li> <li>• When information code does not disappear, check if there's any small foreign matter between the bumper and the main body. If there is, pull the bumper slightly and remove the foreign matter.</li> </ul>
C 06	<p><b>Foreign matter accumulated on the obstacle sensor.</b></p> <ul style="list-style-type: none"> <li>• Turn off the emergency switch and clean the front and rear sensor with a soft cloth.</li> </ul>
C 07	<p><b>Foreign matter</b> accumulated on the cliff sensor.</p> <ul style="list-style-type: none"> <li>• Turn off the emergency switch and clean the cliff sensor with a soft cloth.</li> </ul>

**C 11**

**Main PCB needs to be checked.**

- Turn off and restart the product. If the same problem occurs repeatedly, a service check is required.

# Troubleshooting



Symptom	Checklist
<p><b>The POWERbot is not working at all.</b></p>	<ul style="list-style-type: none"> <li>• Check if the emergency switch is on.</li> <li>• Check if all the icons are displayed on the display panel.</li> <li>• Check if the POWERbot's battery is depleted.</li> </ul> <p>– When "Lo" is displayed, place the POWERbot on the docking station to charge it.</p> <ul style="list-style-type: none"> <li>• Replace the batteries (AAA type) if the remote controller is not working.</li> </ul>
<p><b>The POWERbot has stopped during cleaning.</b></p>	<ul style="list-style-type: none"> <li>• When "Lo" is displayed on the display panel, place the POWERbot on the docking station to charge it.</li> <li>• When POWERbot is immobilized by an obstacle such as a cord, threshold etc, pick it up and move it away from the obstacle.</li> </ul> <p>– If any fabric or string is caught in a drive wheel, turn off the emergency switch and remove the fabric or string before using it again.</p>
<p><b>Suction power is weak.</b></p>	<ul style="list-style-type: none"> <li>• When there's too much dust in the dustbin, suction power may get weakened. Turn off the emergency switch and empty the dustbin.</li> <li>• If the brush is blocked by foreign matter, turn off the emergency switch and remove foreign matter from the brush.</li> <li>• When noise suddenly increase, turn off the emergency switch and empty the dustbin.</li> </ul>
<p><b>The POWERbot cannot find the docking station.</b></p>	<ul style="list-style-type: none"> <li>• Check if there's a power failure or whether the power plug is unplugged.</li> <li>• Remove any obstacles around the docking station that may prevent POWERbot from returning to the docking station.</li> <li>• When there's foreign matter on the charging pins, charging can be affected. Clean the foreign matter off the pins.</li> </ul>



<p><b>The POWERbot suddenly cleans diagonally.</b></p>	<ul style="list-style-type: none"> <li>• Check if the docking station is installed along the grain of wooden floors or tiles.</li> <li>• The POWERbot may clean in a diagonal direction if it is moving to another area using the shortest route. It may also move at a diagonal if it made contact with an obstacles at that angle, if it was charged at the docking station at an angle, or if the grain of the wooden/tile floor skewed is in that direction.</li> </ul>
<p><b>POWERbot does not detect the boundary marker and crosses the boundary.</b></p>	<ul style="list-style-type: none"> <li>• Make sure the boundary markers are attached as (  ) shape at 15 cm before the locations where the POWERbot shouldn't cross.</li> </ul>

<p><b>Point cleaning is not working.</b></p>	<ul style="list-style-type: none"> <li>• If you point the red light directly at POWERbot, it may not move in desired direction.</li> <li>– Point the red light on the floor within 1.6 ft (0.5 m) of the POWERbot.</li> <li>**Do not use point cleaning in direct sunlight, under bright light, or on dark floors.</li> </ul>
<p><b>POWERbot does not clean some places.</b></p>	<ul style="list-style-type: none"> <li>• Check whether the docking station is installed in a narrow passage or near a room door and move it to another place.</li> <li>– If the docking station is installed in a narrow passage or near a room door, the POWERbot cannot pass through the passage or door.</li> </ul>
<p><b>Schedule function cannot be set at the desired time.</b></p>	<ul style="list-style-type: none"> <li>• Check whether the anti-disturbance time is set at the SmartThings App and cancel the anti-disturbance setting.</li> </ul>
<p><b>I have installed the SmartThings app, but the POWERbot fails to be connected.</b></p>	<ul style="list-style-type: none"> <li>• You can use the product after connecting the wireless router and the POWERbot through Easy-Setup according to the procedure.</li> </ul>
<p><b>I fail to log into the Samsung account.</b></p>	<ul style="list-style-type: none"> <li>• Check your ID and password on the screen of the Samsung account.</li> </ul>
<p><b>A message appears saying there is a failure during Easy-Setup.</b></p>	<ul style="list-style-type: none"> <li>• You may have failed temporarily due to the distance from the wireless router or other obstacles. Please try again after a while.</li> </ul>
<p><b>The SmartThings app does not work even though your smartphone is normally connected to the POWERbot.</b></p>	<ul style="list-style-type: none"> <li>• Turn off the SmartThings app and then run it again, or disconnect the smartphone from the wireless router and then connect it again. Or turn off the power supply of the POWERbot, turn it on, wait for a minute or longer, and then run the SmartThings app again.</li> </ul>



<p><b>The functions of the SmartThings App do not work.</b></p>	<ul style="list-style-type: none"> <li>• Check if the remote control blocking function of the POWERbot is set. (When the remote control is locked, the Wi-Fi indicator is turned off.)</li> </ul>
<p><b>The SmartThings Robot Vacuum App fails to start.</b></p>	<ul style="list-style-type: none"> <li>• Check if the POWERbot is connected to the wireless router.</li> </ul>
<p><b>The POWERbot is not connected to Wi-Fi.</b></p>	<ul style="list-style-type: none"> <li>• Check the setting status of the wireless router.</li> </ul>
<p><b>The Intelligent Power Control function works on a normal floor. (It should only work on carpets.)</b></p>	<ul style="list-style-type: none"> <li>• Check whether the floor is not even and then the POWERbot works with its body a bit lifted up.</li> <li>• Check whether there are any foreign matters on the cliff sensor which is at the bottom of the POWERbot.</li> <li>• Check whether the floor color is dark.</li> </ul>
<p><b>The Intelligent Power Control function does not work.</b></p>	<ul style="list-style-type: none"> <li>• When the POWERbot cleans a carpet with short fibre and bright color, it may recognize the carpet as a floor and then the Intelligent power control function may not work.</li> </ul>



<p><b>The Edge Clean Master function does not work.</b></p>	<ul style="list-style-type: none"> <li>• When POWERbot cannot recognize the wall, the Edge clean master may not work.</li> <li>– When an obstacle made of reflective material is in front of the wall</li> <li>– When the wall itself is made of reflective material</li> <li>– When the wall is a dark color</li> </ul>
<p><b>The Edge Clean Master function works though there is no wall or corner.</b></p>	<ul style="list-style-type: none"> <li>• Check whether small obstacles are arranged in a narrow space.</li> <li>• When the POWERbot recognizes the front obstacle as a wall, Edge clean master function may work.</li> </ul>
<p><b>The Edge clean master function works though the POWERbot has not approached a wall or corner.</b></p>	<ul style="list-style-type: none"> <li>• When the degree of the angle of a corner which the POWERbot detects is large, the Edge clean master function may work without approaching the wall or corner.</li> </ul>
<p><b>SmartThings App cannot be installed.</b></p>	<ul style="list-style-type: none"> <li>• SmartThings App operates on Android OS 6.0 or later, iOS 10 or later.</li> <li>• The supporting OS version for SmartThings App may change later.</li> <li>• For rooted smart devices, standard installation and use will not be guaranteed.</li> </ul>
<p><b>A message of product registration failure appears.</b></p>	<ul style="list-style-type: none"> <li>• Try the product registration procedure again by referring to the pop-up messages.</li> <li>• Please refer to the “Setting up the wireless router” in the user manual.</li> <li>• Please refer to the steps for completing the product registration in the user manual section “Adding a device to the SmartThings APP”.</li> <li>• When the product registration fails repeatedly, reset the POWERbot and Smartphone, run the SmartThings App again and try the product registration.</li> </ul>



	<ul style="list-style-type: none"> <li>• The same Samsung account should be used for the login of App and product registration.</li> <li>• All users should use the Samsung account issued by the same country.</li> </ul>
<p><b>During product registration, recharging button is pressed and held as instructed but the next step does not appear.</b></p>	<ul style="list-style-type: none"> <li>• Press the recharging button until you hear it beep.</li> <li>• If the next step does not appear within several seconds, press the recharging button one more time.</li> </ul>
<p><b>During product registration, the wireless router I want to connect cannot be searched.</b></p>	<ul style="list-style-type: none"> <li>• Cancel the product registration, run the SmartThings App again, and try the product registration again.</li> </ul>

<p><b>During product registration, the AP password 111122222 is not input correctly.</b></p>	<ul style="list-style-type: none"> <li>• Press and hold the “[robot vacuum] Samsung” on the network list and delete the network to initialize the password.</li> </ul>
<p><b>During product registration, the password of the connecting wireless router is not input correctly.</b></p>	<ul style="list-style-type: none"> <li>• Cancel the product registration, run the SmartThings App again, and try the product registration again.</li> <li>• Press and hold the wireless router you want to connect on the network list, and delete the network to initialize the password.</li> </ul>
<p><b>A connection cut between the SmartThings App and the POWERbot occurs though the product registration is completed.</b></p>	<ul style="list-style-type: none"> <li>• Refresh the screen and wait.</li> <li>• Run the SmartThings App again.</li> <li>• Check whether there is an internet connection problem. Especially, a firewall may interrupt standard operation.</li> </ul>
<p><b>A connection cut between the SmartThings App and the POWERbot suddenly occurs during normal operation of the app.</b></p>	<ul style="list-style-type: none"> <li>• If the POWERbot is distant from a wireless router, connection cut may occur.</li> <li>• Reset the POWERbot and the smartphone, and check the connection again.</li> <li>• If the connection cut occurs repeatedly, try the product registration again.</li> <li>• When the SSID/password of a wireless router is changed, try the product registration again.</li> </ul>
<p><b>Controlling with SmartThings App does not work since the remote control function is disabled.</b></p>	<ul style="list-style-type: none"> <li>• Remote control function is disabled status. Make the remote control function enabled status with a remote controller.</li> </ul>

**Warning**



This content is compiled from multiple sources and is provided for reference purposes only. It may not be complete or fully applicable to all situations. If you are unable to resolve your issue, please contact the product manufacturer or an authorized service provider for official support.

---

Document generated by [ManualsFile](#)

