

## Overview

### Layout

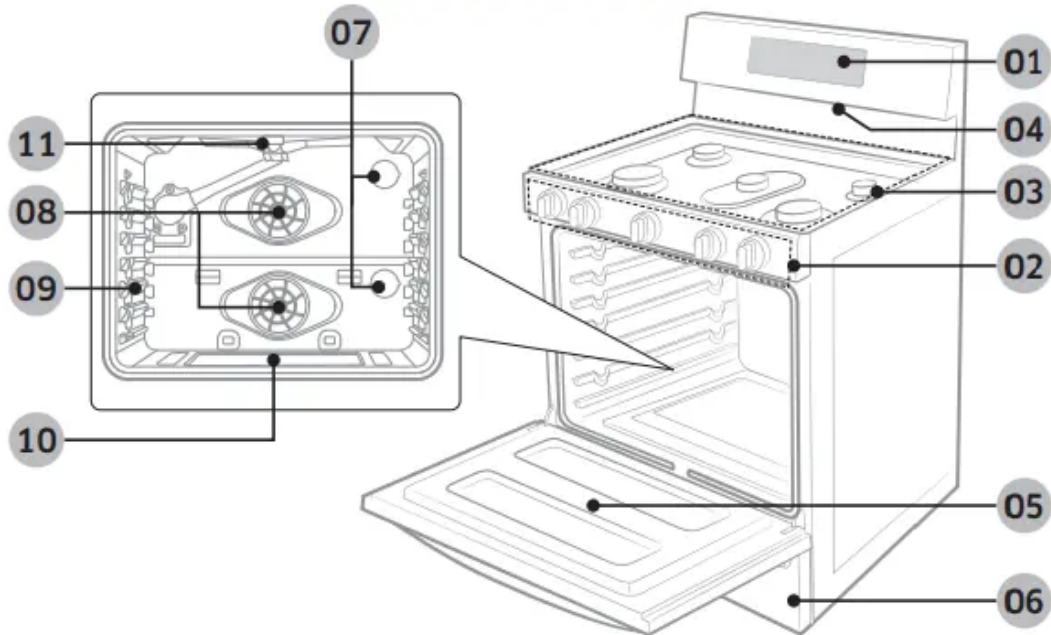

- 01 Display
- 02 Surface burner knobs (5 pcs)
- 03 Surface burners
- 04 Oven vent
- 05 Removable oven door
- 06 Storage drawer
- 07 Oven lights \* (2 locations)
- 08 Convection fan/ Convection heater
- 09 Oven rack system
- 10 Bake oven burner
- 11 Broil oven burner

**NOTE** If you need a part marked with a "\*", you can buy it from the Samsung Contact Center (1-800-726-7864).

## What's included

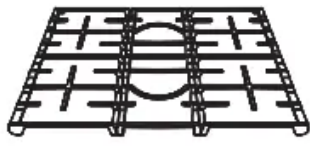

Surface burner grates (3) \*



Surface burners and caps (5) \*



Smart divider (1) \*



Flat rack (3) \*

**NOTE** If you need an accessory marked with an \* (asterisk), please contact the Samsung Call Center at 1-800-726-7864

## Control panel

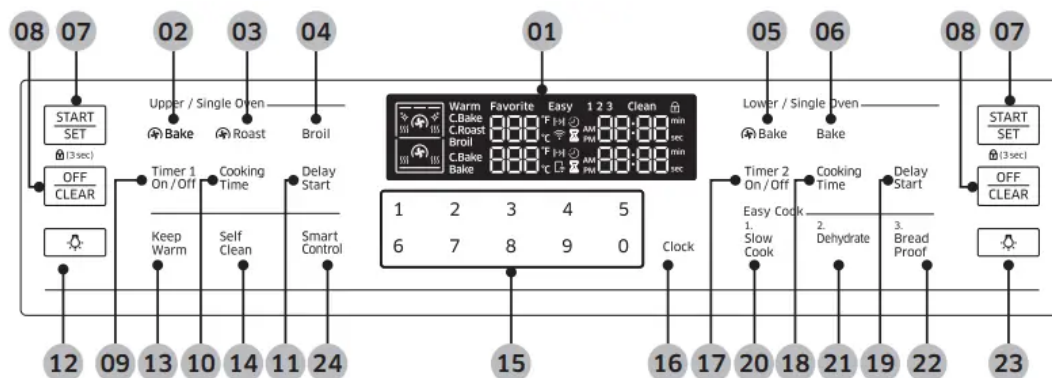

**01 Display:** Shows the time of day, oven temperature, whether the oven is in the bake, broil or self-cleaning mode, and the time set for the timer or automatic oven operations.

- ✨: When you use the self-cleaning feature, this icon appears in the display.

- 🌀: When the oven is pre-heating, this icon appears in the display.

**02 🌀 Bake:** Activate convection baking for the Upper Oven in Twin mode or the entire oven in Single mode.

**03 🌀 Roast:** Activate convection roasting.

**04 Broil:** Broil food using the upper oven burner only.

**05 🌀 Bake:** Activate convection baking for the Lower Oven in Twin mode or the entire oven in Single mode.

**06 Bake:** Bake food using the lower oven burner.

**07 START/SET:** Start a function or set the time.

-  (3sec): Press and hold for 3 seconds to lock the control panel and the door to prevent accidents.

**08 OFF/CLEAR:** Cancel the current operation but not the timer.

**09 Timer1 On/Off:** Activate or deactivate the timer. (Single/Upper in Twin mode)

**10 Cooking Time:** Set the cooking time. (Single/Upper in Twin mode)

**11 Delay Start:** Set the oven to start at a certain time. (Single/Upper in Twin mode)

**12 Oven Light:** Turn on/Turn off the oven light. (Upper)

**13 Keep Warm:** Keep cooked food warm at lower temperatures.

**14 Self Clean:** Burn off food residues in the oven using very high temperatures.

**15 Numbers:** Use to set the times, temperature, or presets.

**16 Clock:** Set the clock time.

**17 Timer2 On/Off:** Activate or deactivate the timer. (Single/Lower in Twin mode)

**18 Cooking Time:** Set the cooking time. (Single/Lower in Twin mode)

**19 Delay Start:** Set the oven to start at a certain time. (Single/Lower in Twin mode)



**20 Slow Cook:** Activates Slow Cook which cooks food slowly at lower temperatures.

**21 Dehydrate:** Activates the Dehydrate function.

**22 Bread Proof:** Activates the Bread proof function.

**23 Oven Light:** Turn on/Turn off the oven light. (Lower)

**24 Smart Control:** Activates the Easy-connection.

-  : When you use the Easy connection, this icon appears in the display.
-  : When the oven is connected to Wifi, this icon appears in the display.

## Gas range

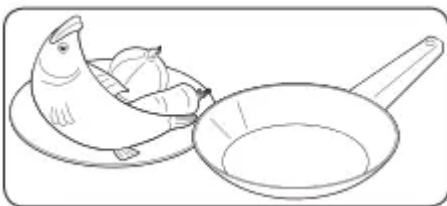

STEP 1 Put all ingredients into a cooking container (pan, pot, etc).

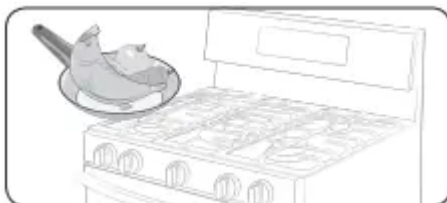

STEP 2 Place the container on a surface burner.

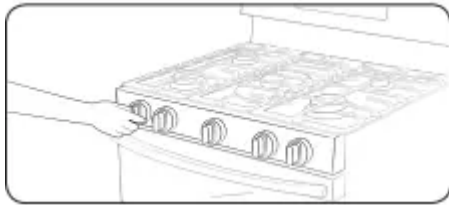

STEP 3 Ignite the surface burner.

## Cookware

### Requirements

- Flat bottom and straight sides.
- Tight-fitting lid.
- Well-balanced with the handle weighing less than the main portion of the pot or pan.

### Material characteristics

- Aluminum: An excellent heat conductor. Some types of food may cause the aluminum to darken. However, anodized aluminum cookware resists staining and pitting.
- Copper: An excellent heat conductor but discolors easily.
- Stainless steel: A slow heat conductor with uneven cooking performance but is durable, easy to clean, and resists staining.
- Cast-Iron: A poor conductor but retains heat very well.
- Enamelware: Heating characteristics depend on the base material.
- Glass: A slow heat conductor. Use only glass cookware that is specified for range top cooking or oven use.

### Size limitations

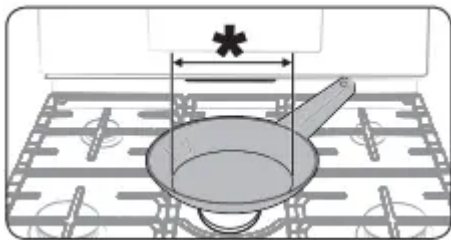

**CAUTION** Do not place a small pan or pot with a bottom diameter of about 6 inches or less on the center grate. This cookware may tip over. Use the rear burners for this small-sized cookware.

\* : 6 inches or less

- Always make sure cookware handles are turned to the side or rear of the cooktop and not over other surface burners. This will minimize the chance of burns, spills, and the ignition of flammable materials that can be caused if pots or pans are bumped accidentally.

- When using glass cookware, make sure it is designed for range top cooking.
- Never leave plastic items on the cooktop. Hot air from the vent can melt or ignite plastic items or cause a building up of dangerous pressure in closed plastic containers.
- Make sure you hold the handle of a wok or a small one-handed pot while cooking.

## Adjusting low flame settings on cooktop burners

All Cooktop burner flames should be checked at their lowest setting. Use the following steps to check and adjust the cooktop burner settings.

**NOTE** Low setting adjustments should always be made with two or more burners operating at the same time.

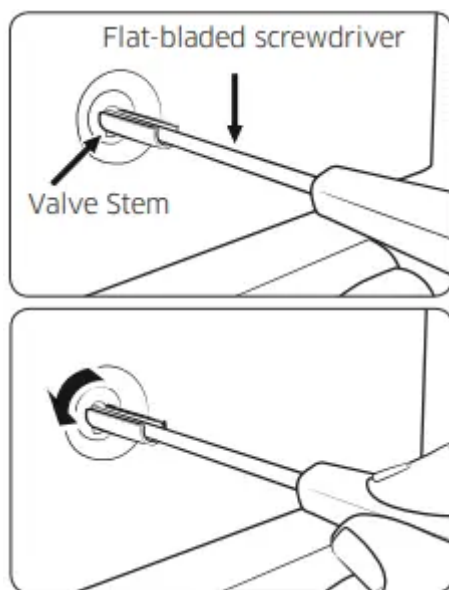

1. Turn on two or more surface burners and set them between MED and HI.
2. Quickly turn one of the control knobs counterclockwise to the lowest setting. The flame should stay lit. If the flame flutter or goes out, adjust the bypass valve on the control valve for that burner.
3. Pull the control knob for that burner straight off.
4. Using a small flat-bladed screwdriver, adjust the bypass valve screw in the base of the valve stem. Turn the bypass valve screw counter clockwise to increase the flame size.
5. Replace control knob and recheck the low flame setting.
6. Repeat step 1 thru 5 to check and adjust the low flame settings on the remaining surface burners.

## Single mode

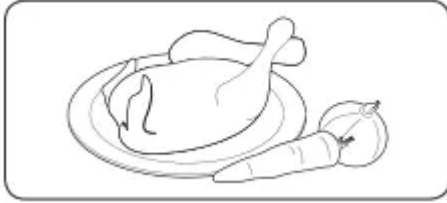

STEP 1 Put all ingredients in a heat-safe container

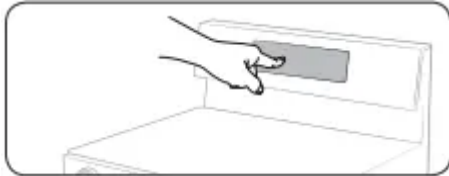

STEP 2 Select a cooking mode, and then start preheating.

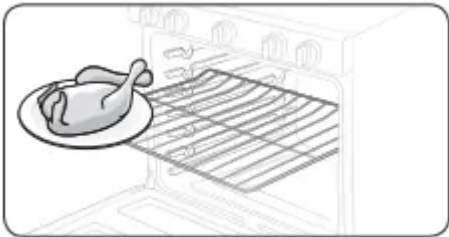

STEP 3 Place the container on a rack.

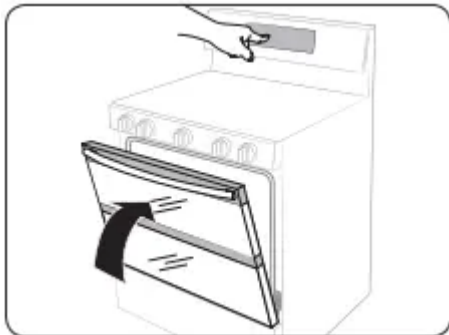

STEP 4 Close the door and start cooking.

**NOTE** The cooling fan automatically runs for a certain amount of time after cooking is complete.

## Twin mode

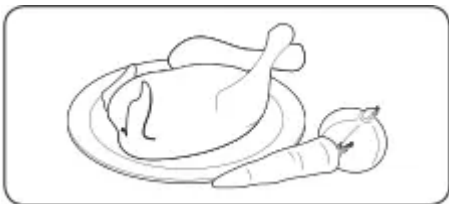

STEP 1 Put all ingredients in a heat-safe container.

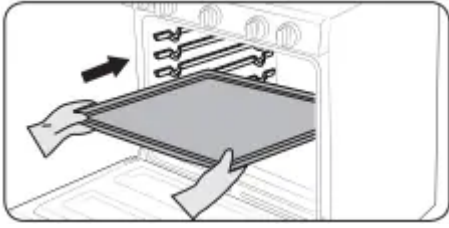

STEP 2 Insert the Smart Divider into 4th rack position.

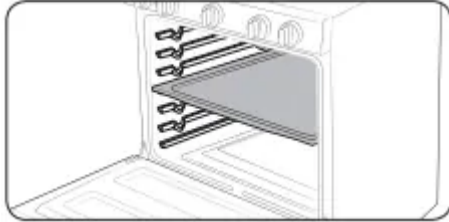

STEP 3 Push the Smart Divider in until the range beeps.

**CAUTION** When the Smart Divider is properly inserted, the "-" icon appears.

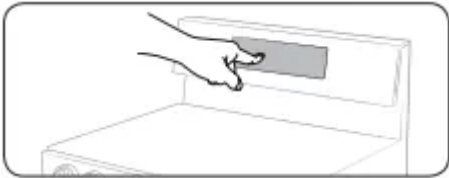

STEP 4 Select a cooking mode, and then start preheating.

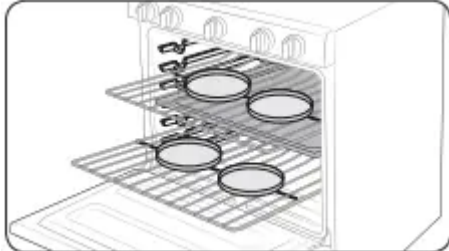

STEP 5 Arrange food containers on the racks.



STEP 6 Close the door and start cooking.

**NOTE**

- To use Twin Mode operation, insert the Smart Divider.
- The cooling fan automatically runs for a certain amount of time after cooking is complete.

- When you are not using the Smart Divider, store it at room temperature.
- Handle the Smart Divider with both hands.
- Use oven gloves when inserting or removing the Smart Divider.
- Do not put food containers directly on the Smart Divider for cooking purposes.
- Please note that the time for the upper and lower ovens to preheat is different.



### CAUTION

Range displays "-dc-"

- Check the Smart Divider to see if it is installed correctly.
- Do not insert/remove the Smart Divider during cooking.

### Cooking mode

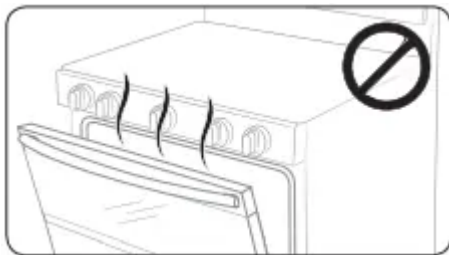

- Make sure to close the oven door before you start cooking.
- If you leave the door open for 20-30 seconds while the oven is in convection baking/roasting, baking, or broiling modes, the oven burner shuts off. To restart the burner, close the door.

### Baking and roasting (Single mode)

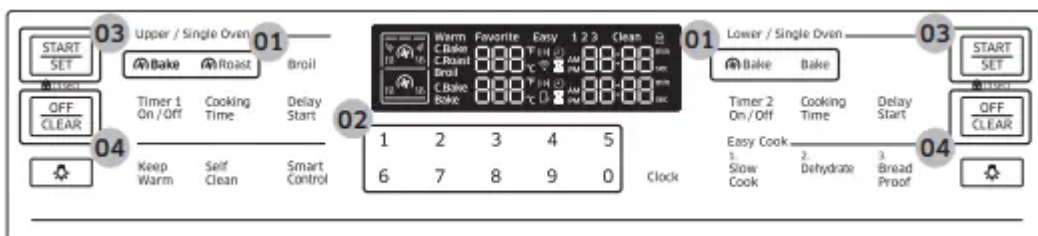

1. Press the Bake, Roast, or Bake pad.
2. If necessary, use the number pad to change the default temperature (350 °F). You can set the oven to any temperature from 175 °F to 550 °F.

3. Press the START/SET pad.

- The oven preheats until it reaches the temperature you set.
- When preheating is complete, place the food in the oven, and then close the door.

4. When cooking is complete, press the OFF/CLEAR pad, and then take out the food

**NOTE** To change the temperature during cooking, repeat steps 1 through 3 above.

### Baking and Roasting (Twin mode upper)

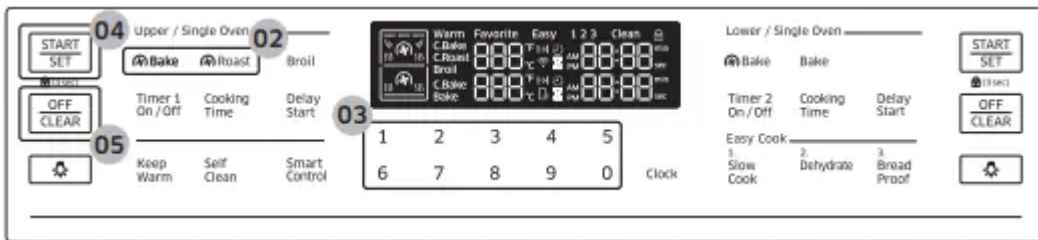

1. Insert the Smart Divider into the cavity.

2. Press the Bake or Roast pad on the left side of the Control Panel.

3. If necessary, use the number pad to change the default temperature (350 °F). You can set the oven to any temperature from 175 °F to 480 °F.

4. Press the START/SET pad.

- The oven preheats until it reaches the temperature you set.
- When preheating is complete, place the food in the upper cavity of the oven, and then close the door.

5. When cooking is complete, press the OFF/CLEAR pad.

### Baking and Roasting (Twin mode lower)

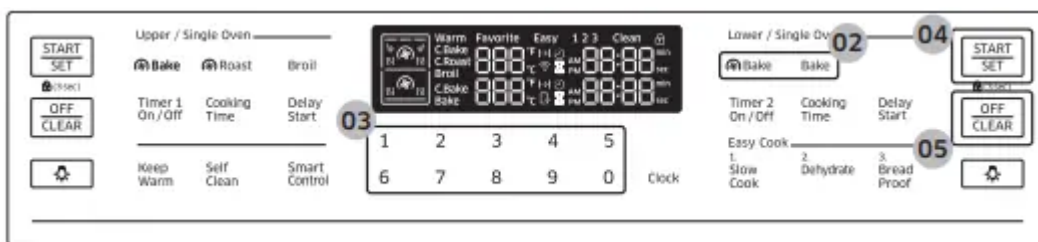

1. Insert the Smart divider into the cavity.

2. Press the Bake or Bake pad on the right side of the Control Panel.

3. If necessary, use the number pad to change the default temperature (350 °F). You can set the oven to any temperature from 175 °F to 480 °F.

4. Press the START/SET pad.

- The oven preheats until it reaches the temperature you set.

- When preheating is complete, place the food in the lower cavity of the oven, and then close the door.

5. When cooking is complete, press the OFF/CLEAR pad.

**NOTE** Your oven has different temperature setting ranges when you use the upper oven and lower oven simultaneously. See "Temperature setting guides" on page 25 for details.

## Broiling

Broiling uses the oven broil burner at the top of the oven to cook and brown food. Meat or fish must be put on a broiling grid in a broiling pan. Preheating for 5 minutes before broiling is recommended.

### Broiling (Single mode)

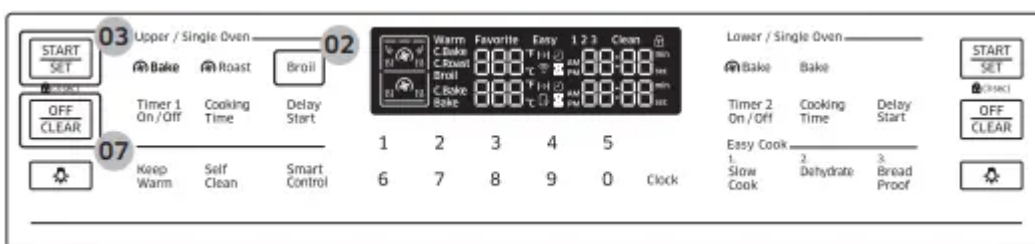

1. Put food on a broiling grid in a broiling pan.
2. Press the Broil pad once for high temperature broiling or twice for low.
3. Press the START/SET pad to start the broiler.
4. Let the oven pre-heat for 5 minutes.
5. Place the pan on the desired rack, and then close the oven door.
6. When one side of the food is browned, turn it over, close the oven door, and start cooking the other side.
7. When cooking is complete, press the OFF/CLEAR pad.

### Broiling (Twin mode)

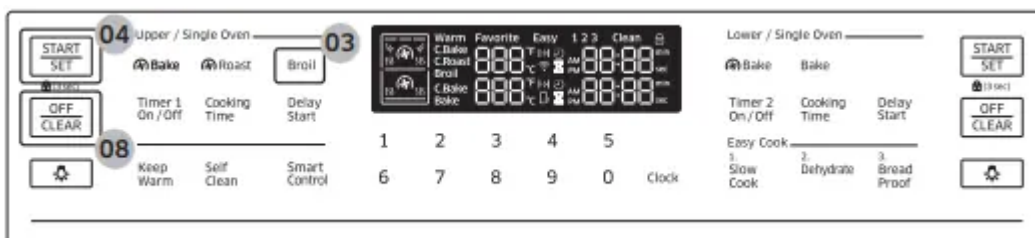

1. Insert the Smart Divider into the cavity.
2. Put food on a broiling grid in a broiling pan.
3. Press the Broil pad once for high temperature broiling or twice for low.
4. Press the START/SET pad to start the broiler.

5. Let the oven pre-heat for 5 minutes.
6. Place the pan on the desired rack in the upper cavity, and then close the oven door.
7. When one side of the food is browned, turn it over, close the oven door, and start cooking the other side.
8. When cooking is complete, press the OFF/CLEAR pad.

## NOTE

- Use the low temperature setting for poultry or thick cuts of meat to prevent overbroiling.
- In general, to prevent overbroiling, press the Broil pad to switch from High to Low.
- Use caution when you open the oven door to turn over the food. The air escaping from the oven will be very hot.
- Your oven has different temperature setting ranges when you use the upper oven and lower oven simultaneously. See "Temperature setting guides" on page 25 for details.

## Using the oven racks

### Single Mode - One Oven Cavity

Your gas oven range comes with 3 racks and 7 rack positions. The rack positions are delineated by rack guides which support the racks. Each rack guide has a stop that prevents racks from loosening during the oven's operation. Each rack has stoppers that need to be placed correctly on the rack guides. The stoppers prevent the racks from accidentally coming out of the oven completely when you pull the racks out.

## Cooking options

**CAUTION** Food that can easily spoil, such as milk, eggs, fish, poultry, and meat, should be chilled in a refrigerator before they are placed in the oven. Even when chilled, they should not stand for more than 1 hour before cooking begins and should be removed promptly when cooking is completed.

### Timed Cook (Single mode)

Timed cooking sets the oven to cook foods at a set temperature for a set length of time. The oven automatically turns off when it finishes.

Mode: Bake /  Bake /  Roast / Slow Cook / Dehydrate

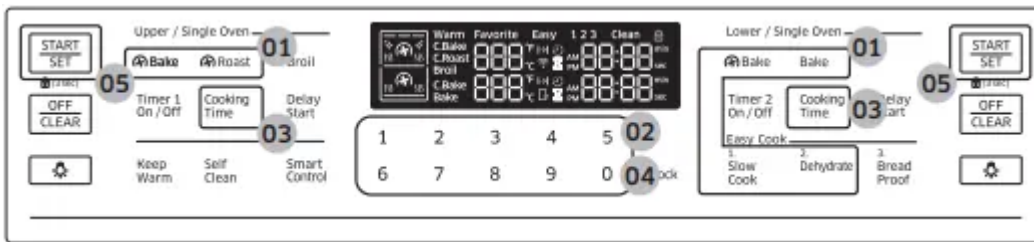

1. Press the pad corresponding to a desired cooking mode such as Bake on the left or right side of the panel.
2. If necessary, change the temperature using the number pad.
3. Press the Cooking Time pad on the left or right side of the panel.
4. Set the cooking time between 1 minute and 9 hours and 59 minutes (9:59) using the number pad.
5. Press the START/SET pad on the right or left side of the panel. The oven will automatically light and start preheating. The temperature will increase until it reaches the temperature you set.
6. When preheating is complete, put the container with the food on a rack, and then close the door. The oven starts cooking for the amount of time you set.
7. When the cooking time has elapsed, the oven will automatically shut off and then beep.

**NOTE** To change the programmed cooking time, press the Cooking Time pad and enter a different time. Then, press the START/SET pad.

### Timed Cook (Upper oven mode)

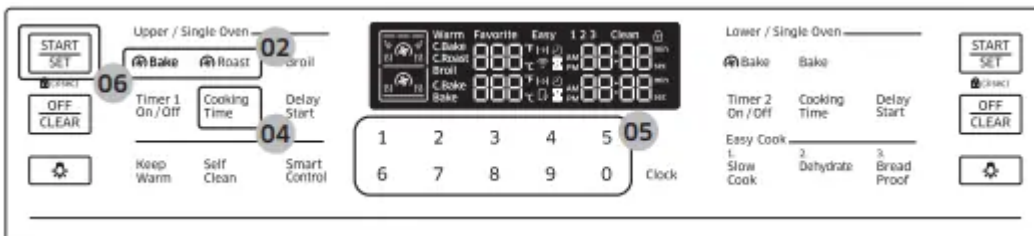

1. Insert the Smart Divider into the cavity.
2. Press the pad corresponding to a desired cooking mode such as  Bake on the left side of the panel.
3. If necessary, change the temperature using the number pad.
4. Press the Cooking Time pad on the left side of the panel.
5. Set the cooking time between 1 minute and 9 hours and 59 minutes (9:59) using the number pad.
6. Press the START/SET pad on the left side of the panel. The oven will automatically light and start preheating. The temperature will increase until it reaches the temperature you set.

- When preheating is complete, put the container with the food on a rack in the upper oven, and then close the door. The oven starts cooking for the amount of time you set.
- When the cooking time has elapsed, the oven will automatically shut off and then beep.

### Timed Cook (Lower oven mode)

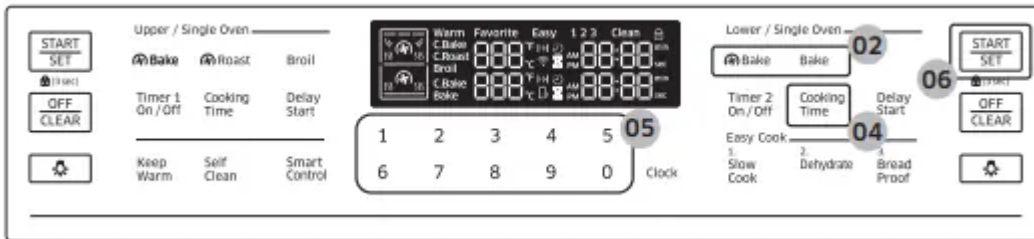

- Insert the Smart Divider into the cavity.
- Press the pad corresponding to a desired cooking mode such as Bake on the right side of the panel.
- If necessary, change the temperature using the number pad.
- Press the Cooking Time pad on the right side of the panel.
- Set the cooking time between 1 minute and 9 hours and 59 minutes (9:59) using the number pad.
- Press the START/SET pad on the right side of the panel. The oven will automatically light and start preheating. The temperature will increase until it reaches the temperature you set.
- When preheating is complete, put the container with the food on a rack in the lower oven, and then close the door. The oven starts cooking for the amount of time you set.
- When the cooking time has elapsed, the oven will automatically shut off and then beep.

### Delay Start (Single mode)

The Delay Start function lets you use the kitchen timer to automatically start and stop another cooking program. Delay Start can be set before other cooking operations for up to 12 hours.

**Mode:** Bake / Bake / Roast / Slow Cook / Dehydrate / Self-clean

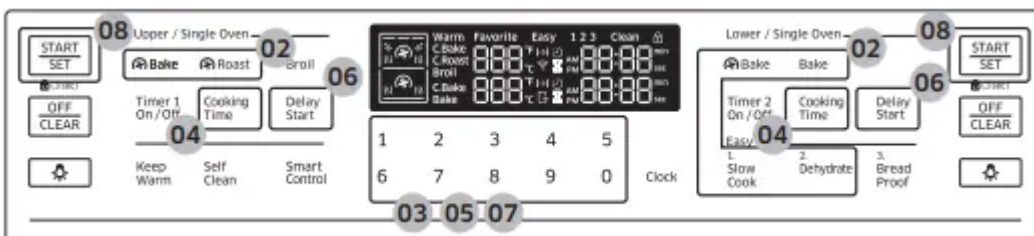

- Place the container with the food on a rack, and then close the door.
- Press the pad corresponding to a desired cooking mode such as Bake on the left or right side of the panel.
- If necessary, change the temperature using the number pad.

4. Press the Cooking Time pad on the left or right side of the panel.
5. Set the cooking time between 1 minute and 9 hours and 59 minutes (9:59) using the number pad.
6. Press the Delay Start pad on the left or right side of the panel.
7. Set the starting time using the number pad.
8. Press the START/SET pad on the left or right side of the panel.
9. The oven starts cooking at the set time, and turns off automatically when it completes cooking.

## NOTE

- To change the starting time, press the Delay Start pad, and enter a new starting time. Then, press the START/SET pad.
- To change the programmed cooking time, press the Cooking Time pad and enter a different time. Then, press the START/SET pad.

## Delay Start (Upper mode)

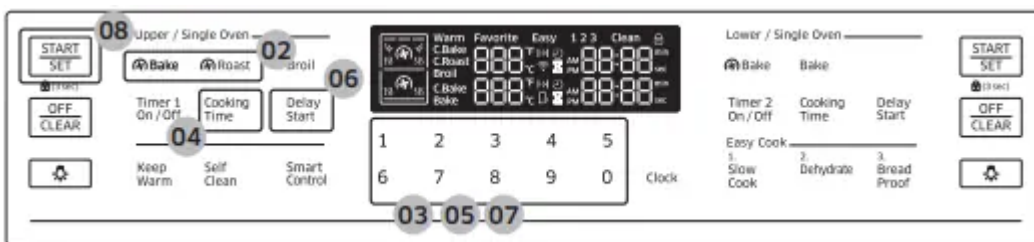

1. Insert the Smart Divider into the cavity. Place the container with the food on a rack in the upper oven, and then close the door.
2. Press the pad corresponding to a desired cooking mode such as Bake on the left side of the panel.
3. If necessary, change the temperature using the number pad.
4. Press the Cooking Time pad on the left side of the panel.
5. Set the cooking time between 1 minute and 9 hours and 59 minutes (9:59) using the number pad.
6. Press the Delay Start pad on the left side of the panel.
7. Set the starting time using the number pad.
8. Press the START/SET pad on the left side of the panel.
9. The oven starts cooking at the set time, and turns off automatically when it completes cooking.

## Delay Start (Lower mode)



1. Insert the Smart Divider into the cavity. Place the container with the food on a rack in the lower oven, and then close the door.
2. Press the pad corresponding to a desired cooking mode such as Bake on the right side of the panel.
3. If necessary, change the temperature using the number pad.
4. Press the Cooking Time pad on the right side of the panel.
5. Set the cooking time between 1 minute and 9 hours and 59 minutes (9:59) using the number pad.
6. Press the Delay Start pad on the right side of the panel.
7. Set the starting time using the number pad.
8. Press the START/SET pad on the right side of the panel.
9. The oven starts cooking at the set time, and turns off automatically when it completes cooking.

### Keep Warm (Single mode only)

Keep cooked food warm at a low temperature up to 3 hours.

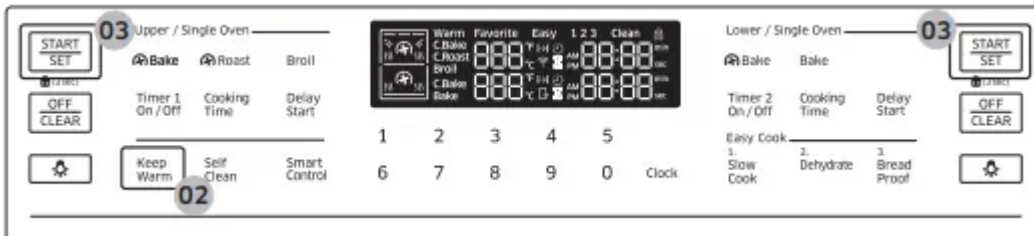

1. Place the container with the food on a rack, and then close the door.
2. Press the Keep Warm pad.
3. Press the START/SET pad on the left or right side of the panel. The oven heats up to 170 °F (77 °C).

### NOTE

- You can cancel warming at any time by pressing the OFF/CLEAR pad.
- To set the warming function during a timed cooking, press the Keep Warm pad in timed cooking mode. When the timed cooking is complete, the oven will lower the temperature to the warming default, and keep that temperature until warming finishes or is canceled.

- Use this function only in Single mode. Your oven cannot maintain the low temperature this function requires during Twin mode cooking.

## Slow cook, dehydrate, proofing

### Slow cook (Single mode only)

The Slow cook feature cooks food slowly at lower oven temperatures. The extended cooking times allow better distribution of flavors in many recipes. This feature is ideal for roasting beef, pork, and poultry. Slow cooking meats may cause the exterior of meats to become dark but not burnt. This is normal.

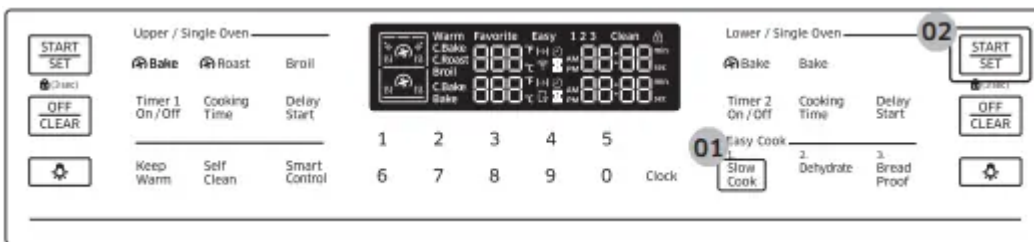

1. Press Slow Cook once for HI or twice for LO.
2. Press START/SET.

**NOTE** Use only 1 rack and place the rack in position 1 or 2 for the best results. Preheating the oven is not necessary.

### Dehydrate (Single mode only)

Dehydrate dries food or removes moisture from food via heat circulation. After drying the food, keep it in a cool and dry place. For fruit, adding lemon or pineapple juice or sprinkling sugar on the fruit helps the fruit retain sweetness.

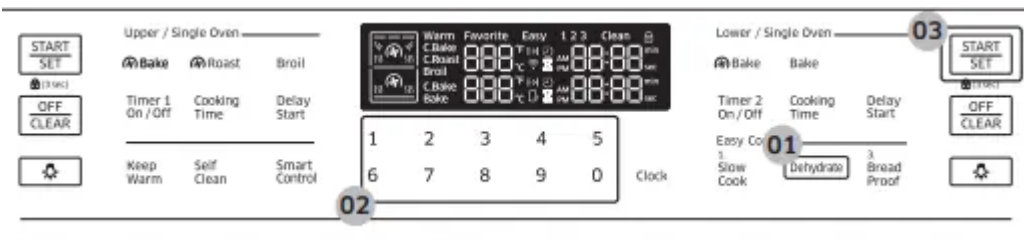

1. Press Dehydrate. The default temperature is 150 °F.
2. Enter the temperature you want on the number pad. (100 °F-175 °F)
3. Press START/SET.

### Recommended Dehydration Temperatures

Category	Rack position	Temperature (°F)
Vegetables or Fruit	3 or 4	100-150
Meat	3 or 4	145-175

## NOTE

- Drying time depends on the amount of moisture inside of the food, the size of the food, and the humidity in the air.
- Preheating the oven is not necessary

### Bread Proof (Single mode only)

The Bread Proof function automatically provides the optimum temperature for the bread proof process, and therefore does not have a temperature adjustment. If you press Bread Proof when the oven temperature is above 100 °F, Hot will appear in the display. Because this function produces the best results when started while the oven is cool, we recommend that you wait until the oven has cooled down and Hot disappears from the display.

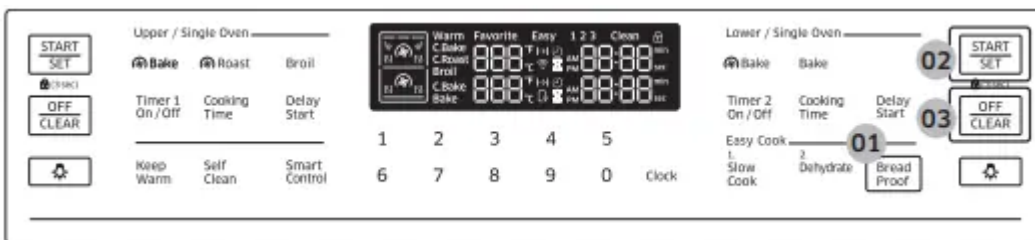

1. Press Bread Proof.
2. Press START/SET.
3. Press OFF/CLEAR at any time to turn off the Bread Proof function.

**NOTE** Use rack position 3 for bread proofing.

## Non-cooking functions

### Temperature adjust

The oven temperature has been calibrated at the factory. When first using the oven, follow the recommended recipe times and temperatures. If it appears that the oven is too hot or too cool, you can recalibrate the oven temperature. Before recalibrating, test a recipe by using a temperature setting that is higher or lower than recommended. The baking results should help you decide how much of an adjustment is needed. The oven temperature can be adjusted by  $\pm 35$  °F ( $\pm 19$  °C).

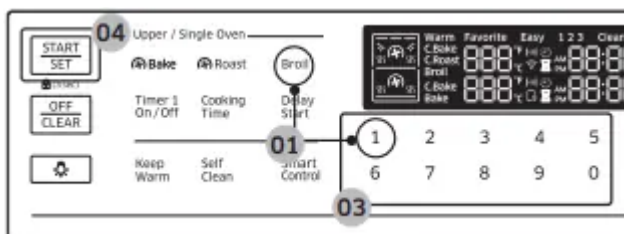

1. Press the Broil pad and 1 on the number pad simultaneously for 3 seconds.
2. Press the Broil pad to select a higher(+) or lower(-) temperature.
3. Enter an adjusting temperature value (0-35) using the number pad.

4. Press the START/SET pad to save the changes.

**NOTE** This adjustment does not affect the broiling or the self-cleaning temperature, and is retained in memory after a power failure.

### Temp. Unit (°F / °C)

Change the temperature format of the oven to Fahrenheit or Centigrade. The default is Fahrenheit

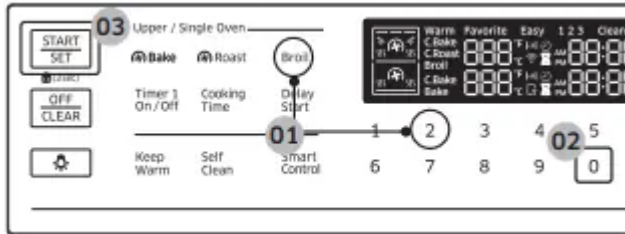

1. Press the Broil pad and 2 on the number pad simultaneously for seconds.
2. Press 0 on the number pad to select Fahrenheit or Centigrade.
3. Press the START/SET pad to save the changes.

### Auto Conversion

Auto Conversion automatically converts regular baking temperatures to convection baking temperatures. For example, if you enter a regular recipe temperature of 350 °F and press START/SET, the oven displays the converted temperature of 325 °F.

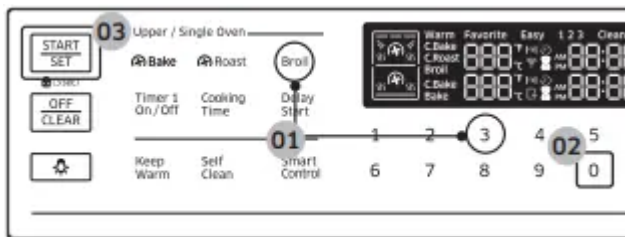

1. Press the Broil pad and 3 on the number pad simultaneously for 3 seconds.
2. Press 0 on the number pad to select Off or On. (Default setting is \*OFF.)
3. Press the START/SET pad to save the changes.

### Energy saving

This will automatically turn off the oven 12 hours after baking starts or 3 hours after broiling starts.

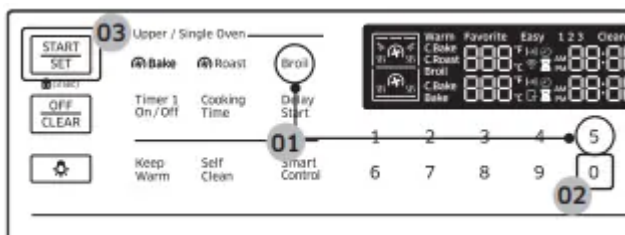

1. Press the Broil pad and 5 on the number pad simultaneously for 3 seconds.
2. Press 0 on the number pad to select Off or On.

3. Press the START/SET pad to save the changes.

## Sound

Mute/unmute the range.

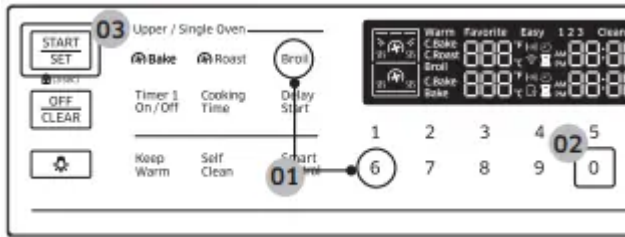

1. Press the Broil pad and 6 on the number pad simultaneously for 3 seconds.
2. Press 0 on the number pad to select unmute or mute.
3. Press the START/SET pad to save the changes.

## Demo mode

This is used by retailers for display purposes only. In this mode, the heating element does not operate.

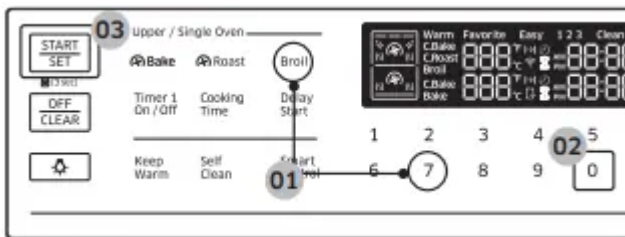

1. Press the Broil pad and 7 on the number pad simultaneously for 3 seconds.
2. Press 0 on the number pad to select Off or On.
3. Press the START/SET pad to save the changes.

## Oven light

Turns the oven light on and off.

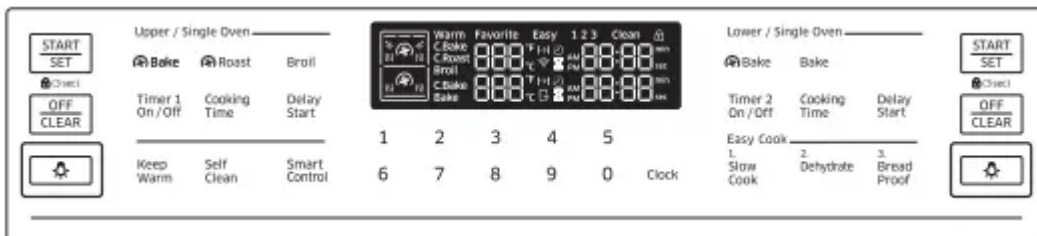

Press the Oven Light pad to turn the oven light on and off.

## Oven lock

Lock the control panel and the door to prevent accidental operations and/or product tipping.

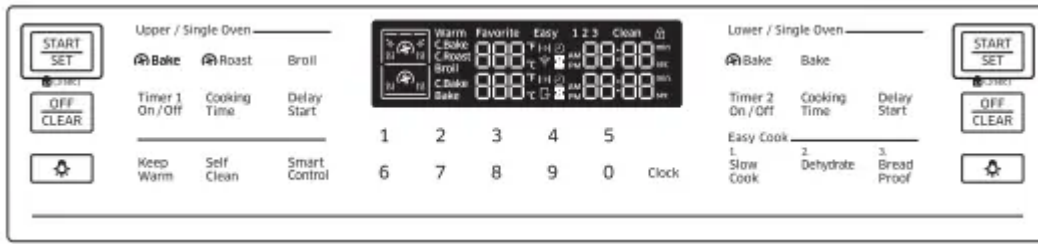

Press and hold the START/SET pad for 3 seconds to lock or unlock both the control panel and the door. When the range lock is on, the range panel does not operate and the range door is locked and cannot be opened.

## Smart Control - Controlling your oven remotely

### How to connect the oven

1. Download and open the SmartThings app on your smart device.
2. Follow the app's on-screen instructions to connect your range.
3. Once the process is complete, the connected  icon located on your range displays and the app confirms you are connected.
4. If the connection icon does not turn on, follow the instruction in the app to reconnect.

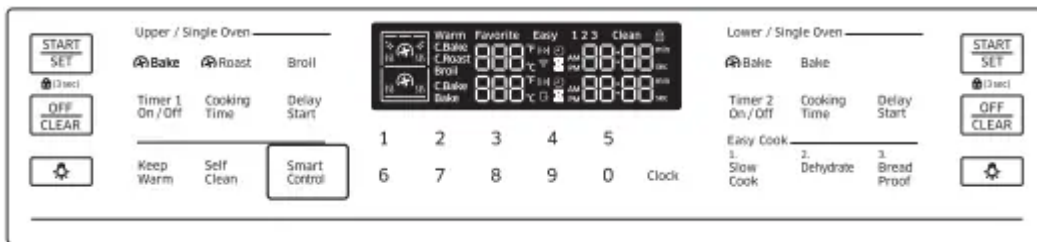

### To control the oven remotely

1. Press Smart Control.  appears in the display. The oven can now be controlled remotely using a connected remote device.
2. Select the oven icon in the SmartThings app to open the Oven Control app. When the app is connected to the oven, you can perform the following functions through the application:

Oven remote control using the SmartThings app	
Oven/ Cooktop Monitoring	<ul style="list-style-type: none"> <li>• Check the status of the oven</li> <li>• Monitor the on/off status of each cooktop burner.</li> </ul>
Oven Remote Control	<ul style="list-style-type: none"> <li>• Set or adjust oven settings remotely.</li> </ul>
My Cooking	<ul style="list-style-type: none"> <li>• Turn the oven off remotely.</li> <li>• Once cooking starts, change the set cooking time or temperature remotely.</li> </ul>
Error Check	<ul style="list-style-type: none"> <li>• Automatically recognize errors.</li> </ul>
<ul style="list-style-type: none"> <li>• If  is not shown in the display, you are still able to monitor the oven and cooktop status and turn the oven off.</li> </ul>	

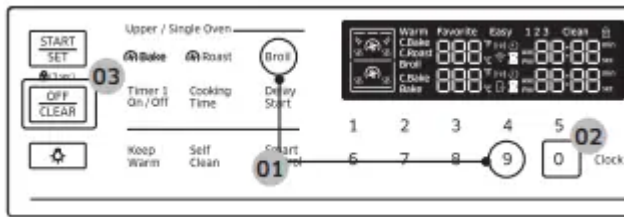

## WI-FI On/Off

If you activate the WI-FI Off mode, any mobile devices cannot connect to the range.



1. Press the Broil pad and 9 on the number pad simultaneously for 3 seconds.
2. Press 0 on the number pad to select Off or On.
3. Press the START/SET pad to save the changes.

## NOTE

- Opening the oven door or pressing Smart Control will delete  from the display and prevent most of the remote functions from operating.
- When oven cooking is finished or cancelled,  is removed from the display.
- For safety reasons, you cannot turn on the gas oven remotely.
- For safety reasons, you must specify the cooking time to enable remote control.
- The oven continues operating even if the Wi-Fi connection is lost.
- Smart Control will not work properly if the Wi-Fi connection is unstable.
- See the SmartThings app manual for detailed information.

## Maintenance

### Cleaning

#### Control panel

First, lock the control panel and the door to prevent accidental operations and/or product tipping.

1. Press and hold the START/SET pad for 3 seconds to lock both the control panel and the door.
2. Clean the control panel using a soft cloth dampened with plain water, warm soapy water, or glass cleaner. Do not spray cleansers directly onto the control panel.
3. When done, press and hold the START/SET pad again for 3 seconds.

## WARNING

- Make sure the control panel turns off and all surfaces of the range are cool before cleaning. Otherwise, you can get burned.

- If the range has been moved away from the wall, make sure the anti-tip device is reinstalled properly when the range has been put into place again. Otherwise, the range may tip over, causing physical injuries.
- Do not use steel-wool or abrasive cleansers of any kind. These can scratch or damage the surface.

### **Stainless steel surface**

1. Remove any spills, spots, and grease stains using a soft, wet cloth.
2. Apply an approved stainless steel cleanser to a cloth or paper towel.
3. Clean one small area at a time, rubbing with the grain of the stainless steel if applicable.
4. When done, dry the surface using a soft, dry cloth.
5. Repeat steps 2 through 4 as many times as necessary.

### **CAUTION**

- Do not use a steel-wool pad or abrasive cleanser on stainless steel surfaces. They will scratch the surface.
- Do not spray any type of cleanser into the manifold holes. The ignition system is located in those holes and must be kept free of moisture.

### **Racks**

To keep the racks clean, remove them from the cavity, and soak them in lukewarm, soapy water. Then, scour impurities off of the racks using a plastic scouring pad. If the racks do not slide in and out smoothly after you have cleaned them, rub the side rail guides with wax paper or a cloth containing a few drops of cooking oil. This will help the racks glide more easily on their tracks.

### **Door**

Do not remove the inner gasket of the oven door for cleaning.

### **Inner side**

- Inner surface: Clean the inner side of the door manually using a soapy plastic scouring pad, and then wipe with a dry cloth. Take care not to get the gasket wet or allow moisture into the door.
- Inner glass: The inner glass is cleaned automatically during the self-cleaning cycle.

### **Outer side**

- Outer surface: Follow the cleaning instructions for stainless steel surfaces in the previous section.
- Outer glass: Clean the outer glass using a glass cleanser or soapy water. Rinse and dry thoroughly. Take care not to get the gasket wet or allow moisture into the door.

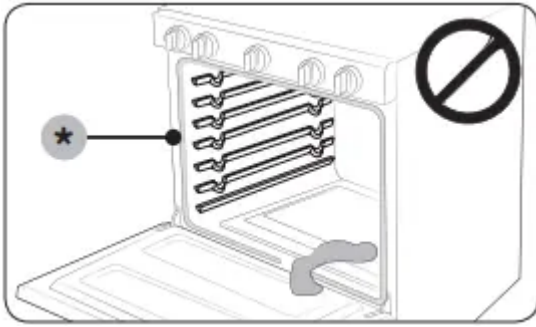

## CAUTION

- Do not let moisture enter the door or contact the door gasket (\*). Moisture may reduce the gasket's performance.
- Do not let moisture or water enter the burners, electrical controls, or switches.

## Surface burners

### Burner controls

Make sure all surface burner knobs are in the OFF position.

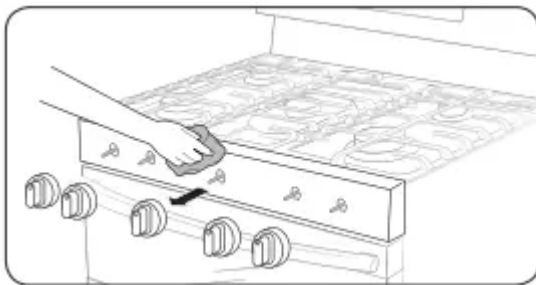

1. Pull the knobs off the control valve stems as shown.
2. Clean the knobs in warm, soapy water. Then, rinse and dry them thoroughly.
3. Clean the stainless steel surfaces using stainless steel cleaner.
4. Push the knobs back onto the control valve stems.

## CAUTION

- Do not clean the control knobs in a dish washer.
- Do not spray cleansers directly onto the control panel. Moisture entering the electric circuits may cause electric shock or product damage.

## Cooktop surface

The porcelain-enamelled cooktop surface needs to be kept clean. We recommend that you remove food spills immediately after they take place.

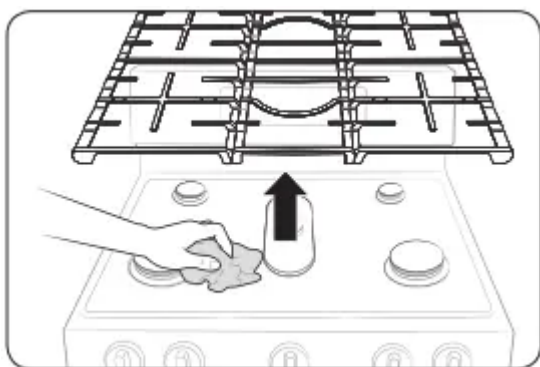

1. Turn off all surface burners.
2. Wait until all burner grates cool down, and then remove them.
3. Clean the cooktop surface using a soft cloth. If food spills run into the gaps of the burner components, remove the burner cap and the head, and then wipe up the spills.
4. When cleaning is finished, re-install the burner components, and then put the burner grates into position.

### CAUTION

- Do not use a steel-wool pad or abrasive cleaner, which can scratch or damage the enamel surface.
- Do not remove the cooktop surface to clean it. The gas lines leading to the burner manifolds can be damaged, resulting in a fire or system failure

### How to run a self-cleaning cycle

Make sure the door lock is released. Remove all racks from the oven cavity

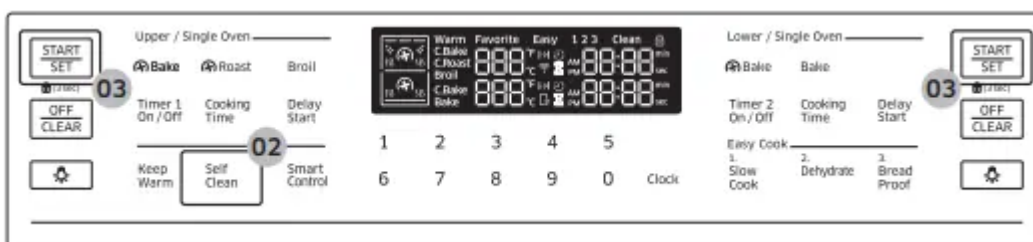

1. Make sure the oven door is unlocked and closed completely.
2. Press the Self Clean pad once. Then, select the cleaning time by pressing the Self Clean pad one or more times in accordance with the table below.

Once	Twice	Three times
3 hour	5 hour	2 hour

3. Press the START/SET pad. The oven door is locked and the oven begins to heat up.
4. When the cycle is complete, the oven beeps 6 times. The door will remain locked and the Lock icon will blink until the oven temperature falls below 400 °F (204 °C).

5. When the Lock icon changes to an open lock, you can open the oven door. The Lock icon changes to an open lock when the oven temperature drops below 400 °F (204 °C).

6. Press the OFF/CLEAR pad to display the time of the day.

**CAUTION** Do not use the surface burners while the gas oven is performing a self-cleaning cycle.

To delay starting the self-cleaning cycle

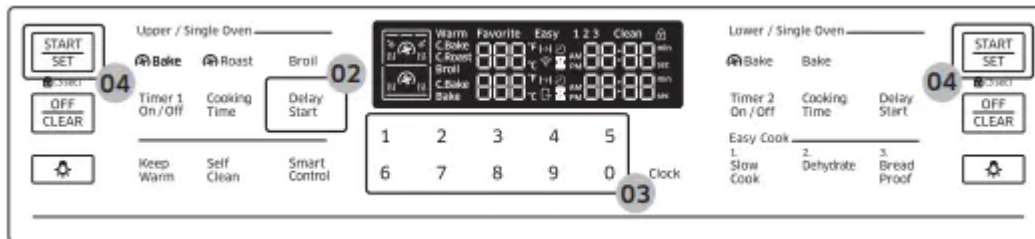

1. Repeat steps 1 and 2 on the previous page.
2. Press the Delay Start pad. The oven door locks.
3. Set the time you want the oven to start self-cleaning using the number pad.
4. Press the START/SET pad. The oven will start self-cleaning at your specified time.

### To cancel the self-cleaning cycle

You may find it necessary to stop or interrupt a self-cleaning cycle due to smoke in the oven. To turn off the self-cleaning cycle, press the OFF/CLEAR pad. The cycle turns off, but the door remains locked and the Lock icon blinks until the oven temperature falls below 400 °F (204 °C).

### After self-cleaning

- The door stays locked until the internal oven temperature falls below 392 °F.
- When the oven has cooled down, wipe the oven surfaces with a cloth to remove ash residue.
- Stubborn stains can be removed using a steel-wool pad. Lime deposits can be removed using a vinegar-soaking cloth.
- If you are not satisfied with the cleaning results, repeat the cycle. "HOT" appears on the display until the oven cools down. Wait until the message disappears, and then start a new cycle.
- The cooling fan automatically runs for certain amount of time after self-cleaning.
- Self-cleaning does not operate within 2 hours after running the self-cleaning cycle.

**CAUTION** Do not attempt to open the oven door immediately after the self-cleaning cycle is complete. The oven is still very hot when the door unlocks. Escaping hot air and/or steam could burn you.

## Replacing the Oven Light

The oven light is a standard 40-watt appliance bulb. It comes on when you open the oven door.

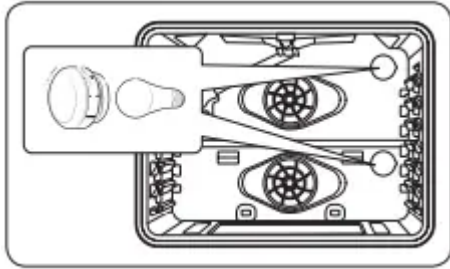

1. Turn off the oven.
2. Make sure the oven and oven light are cool.
3. Open the door, and remove the glass cover by turning it counterclockwise.
4. Remove the oven light from the socket by turning it counterclockwise.
5. Insert a new 40-watt appliance bulb into the socket, and then turn it clockwise to tighten.
6. Reinsert the glass cover, and then turn it clockwise to tighten.

**CAUTION** To prevent electric shock, make sure the oven is turned off and cool before replacing the oven light.

### NOTE

- The oven light does not operate during the self-cleaning cycle.
- Remove the racks if they prevent you from accessing the oven light.

## Storage drawer

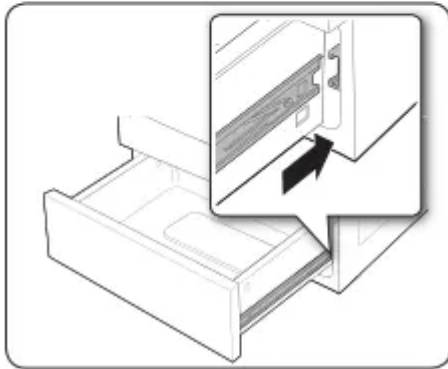
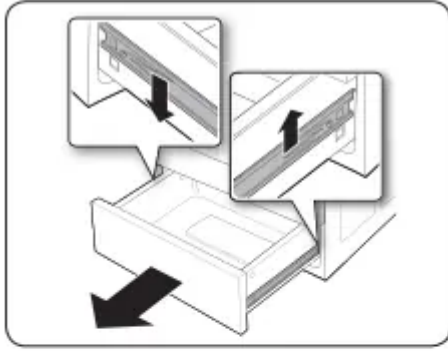

1. Slide open the drawer until it stops.
2. Locate the roller guide clips on either side. Using both hands, pull down the left clip while lifting the right clip, and then remove the drawer.
3. Clean the drawer in warm, soapy water using a cloth or soft brush. Then, rinse and dry it thoroughly.
4. Put the drawer in the roller guides on either side, and then snap the clips into place.

## Troubleshooting

If you encounter a problem with the range, check the tables starting below, and then try the suggested actions.

### Checkpoints

#### Gas safety

Problem	Possible cause	Action
You smell gas.	The surface burner knob is not in the OFF position and the burner is not lit.	Turn the burner knob to OFF.
	There is a gas leak.	Clear the room, building, or area of all occupants. Immediately call your gas supplier from a neighbor's phone. Do not call from your phone. It is electrical and could cause a spark that could ignite the gas. Follow the gas supplier's instructions. If you cannot reach your gas supplier, call the fire department.

### Surface burner



<b>Problem</b>	<b>Possible cause</b>	<b>Action</b>
All burners do not light.	The power cord is not plugged into the electrical outlet.	Make sure the electrical plug is plugged into a live, properly grounded outlet.
	A fuse in your home may be blown or the circuit breaker tripped.	Replace the fuse or reset the circuit breaker.
	The gas supply is not properly connected or turned on.	See the Installation Instructions that came with your range.
The surface burners do not light.	The control knob is not set properly.	Push in the control knob and turn it to the LITE position.
	The burner caps are not in place.  The burner base is misaligned.	Clean the electrodes.  Put the burner cap on the burner head.  Align the burner base.
A surface burner clicks during operation.	The control knob has been left in the LITE position.	After the burner lights, turn the control knob to a desired setting. If the burner still clicks, contact a service technician.
The burners do not burn evenly	The surface burner components and caps are not assembled correctly and level.	See page 40.
	The surface burners are dirty.	Clean surface burner components. (See page 39.)
Very large or yellow surface burner flames.	The wrong burner orifice is installed.	Check the burner orifice size. Contact your installer if you have the wrong orifice (LP gas instead of natural gas or natural gas instead of LP gas).
The surface burners light but	The oven door lock is turned on.	The display will show the Lock icon. Hold the oven door open and press

the oven burners do not light.		the START/SET pad for 3 seconds. The oven will beep and the Lock icon will turn off.
	The Gas Pressure Regulator shut off switch is in the off position.	Call a qualified service technician.

**Oven**



<b>Problem</b>	<b>Possible cause</b>	<b>Action</b>
The oven control beeps and displays an information code.	There may be a malfunction. See the "Information codes" chart on page <OV>.	Press the OFF/CLEAR pad, and then restart the oven.  If the problem persists, disconnect all power to the range for at least 30 seconds and then reconnect the power. If this does not solve the problem, call for service.
Very large or yellow oven burner flames	The oven burner air adjustment shutters need to be adjusted.	Call for a qualified service technician.
	The gas supply is not properly connected or turned on.	See the Installation Instructions that came with your range.
The oven temperature is too hot or cold.	Oven thermostat needs adjustment.	See page 34.
An oven burner will not shut off.	The oven door lock is turned on.	The display will show the Lock icon. Hold the oven door open and press the START/SET pad for 3 seconds. The oven will beep and the Lock icon will turn off.
	The Sabbath function has been activated.	SAB and the time of day will show in the display. All other controls and signals will be deactivated. To turn off the oven only, press the OFF/CLEAR pad.  To cancel the Sabbath function and reactivate the controls and signals, press and hold the Bake and Touch to Wake-Up pads simultaneously for 3 seconds.
The oven light (lamp) will not turn on.	The oven door lock is turned on.	The display will show the Lock icon. Hold the oven door open and press the START/SET pad for 3 seconds. The oven will beep and the Lock icon will turn off.

	The Sabbath function has been activated.	SAb and the time of day will show in the display. All other controls and signals will be deactivated. To cancel the Sabbath function and reactivate the light switch and other controls, press and hold the Bake and Touch to Wake-Up pads simultaneously for 3 seconds.
	A loose or burned-out bulb.	See page 42.
	The switch operating the oven light needs to be replaced.	Call for a qualified service technician.
Oven smokes excessively during broiling.	Meat or food was not properly prepared before broiling.	Cut away excess fat and/or fatty edges that may curl.
	An improperly positioned top oven rack.	See broiling guide on page 25.
	The controls are not being set properly.	See page 24.
	Greasy buildup on oven surfaces.	Regular cleaning is necessary when broiling frequently.
Cooking is finished, but the cooling fan is still running.	the fan automatically runs for a certain amount of time to ventilate inside the oven.	This is not a product malfunction, so there is no need to worry
Oven will not self-clean.	The oven door lock is turned on.	The display will show the Lock icon. Hold the oven door open and press the START/SET pad for 3 seconds. The oven will beep and the Lock icon will turn off.
	The Smart Divider is installed in the oven.	Self-clean will not operate with the Smart Divider installed. Remove it from the oven.

	The oven is too hot.	Let the oven cool down and reset the controls. The self-clean cycle will not lock the oven door if the oven temperature is too hot. The door must lock before the selfclean cycle can start.
	The self-cleaning oven controls are not properly set.	Reset the self-cleaning oven controls. (See page 41.)
Crackling or popping sound.	This is normal.	This is the sound of the metal heating and cooling during any cooking or cleaning function.
Excessive smoking during a self-cleaning cycle.	This is the first time the oven has been cleaned.	This is normal. The oven will always smoke more the first time it is cleaned.  Wipe up all excessive soil before starting the self-cleaning cycle. If smoke persists, press the OFF/ CLEAR pad. Open the windows to clear the smoke from the room. After the oven has cooled and unlocked, wipe up excessive soil and reset the oven for selfcleaning.
The oven door will not open after a selfcleaning cycle.	This is normal.	The oven door will stay locked until the oven temperature drops below 392 °F.
The oven is not clean after a self-cleaning cycle.	A fine dust or ash is normal.	This can be wiped clean with a damp cloth.  Set the self-cleaning cycle for a longer cleaning time.  Set the self-cleaning cycle for a longer cleaning time.  Extremely dirty ovens require hand-cleaning of excessive spillovers and food buildup before you start a self-cleaning cycle. Multiple self-cleaning cycles may

		be necessary to completely clean the oven.
Steam or smoke coming from under the control panel.	This is normal.	The oven vent is located there. More steam is visible when you use the convection functions or when baking or roasting multiple items at the same time.
A burning or oily odor coming from the vent.	This is normal for a new oven and will disappear within 1/2 hour of the first bake cycle.	To speed the process, set a selfcleaning cycle for a minimum of 3 hours. (See page 41.)
A strong odor.	This is temporary	The insulation around the inside of the oven emits an odor the first few times the oven is used.
Oven racks are difficult to slide.	This is normal.	Apply a small amount of vegetable oil to a paper towel and wipe the edges of the oven racks with the paper towel. Racks become dull and hard to slide if they are left in the oven during a self-clean cycle.
Fan noise	This is normal	The convection fan runs until the function is over or the door is opened.
The convection fan is not working.	This is normal	The fan starts automatically when the oven reaches the preheat temperature.

## Others

<b>Problem</b>	<b>Possible cause</b>	<b>Action</b>
The product is not level.	The appliance has been installed improperly.  The leveling leg(s) is (are) damaged or uneven.	Make sure the floor is level, strong, and stable. If the floor sags or slopes, contact a carpenter.  Check and level the range. (See the Installation Instructions.)
	The kitchen cabinets are not properly aligned and make the range appear to be not level.	Ensure that cabinets are square and provide sufficient room for installation.
The display goes blank.	The electrical outlet Ground Fault Interrupter (GFI or GFCI) has been tripped and needs to be reset.  Your digital control has been damaged.	Replace fuse or reset circuit breaker.
Food does not bake or roast properly in the oven.	The wrong cooking mode is selected.	See page 21
	The oven racks have not been positioned properly for the foods being cooked.	See page 26
	Incorrect cookware or cookware of improper size is being used	See page 17
	The oven thermostat needs adjustment.	See page 34
	There is aluminum foil on the racks and/or oven bottom.	Remove foil.
	The clock or timers are not set correctly.	See page 16
		See page 24.

Food does not broil properly in the oven.	The oven controls are not set properly.	
	The oven door was not closed during broiling.	See page 21.
	The rack has not been properly positioned.	See the broiling guide on page 25.



## Information codes



Code symbol	Meaning	Solution
C-20	Check the oven sensor.	<ol style="list-style-type: none"> <li>1. Press the OFF/CLEAR pad, and then restart the oven.</li> <li>2. If the problem persists, disconnect all power to the range for at least 30 seconds, and then reconnect the power.</li> </ol>
C-21	Oven overheating.	
C-30	Check the PBA NTC Sensor	
C-31	Check the PBA NTC Sensor	
C-A2	Check the cooling system.	
C-d1	Check the door lock.	
C-F0	Check the PCB signals.	
C-F2	Check the Touch PBA signals.	
C-d0	Check the control panel pads	
-dC-	Check the divider switch.	<ol style="list-style-type: none"> <li>1. If the Divider is in the oven, make sure it is pushed in all the way.</li> <li>2. If the Divider is not in the oven, see if something is pressing against the divider switch in the back of the oven.</li> <li>3. If the Divider is all the way in or there is nothing pressing against the Divider switch, press the OFF/CLEAR pad, and then restart the oven. If the problem persists, disconnect all power to the oven range for at least 30 seconds, and then reconnect the power.</li> </ol>



\*\* If these solutions do not solve the problem, contact a local Samsung service center or call 1-800-SAMSUNG (1-800-726-7864).

### **Warning**

This content is compiled from multiple sources and is provided for reference purposes only. It may not be complete or fully applicable to all situations. If you are unable to resolve your issue, please contact the product manufacturer or an authorized service provider for official support.

---

Document generated by [ManualsFile](#)