

## PRODUCT OVERVIEW

The images in this guide may be different from the actual components and accessories, which are subject to change by the manufacturer without prior notice for product improvement purposes.

### Exterior

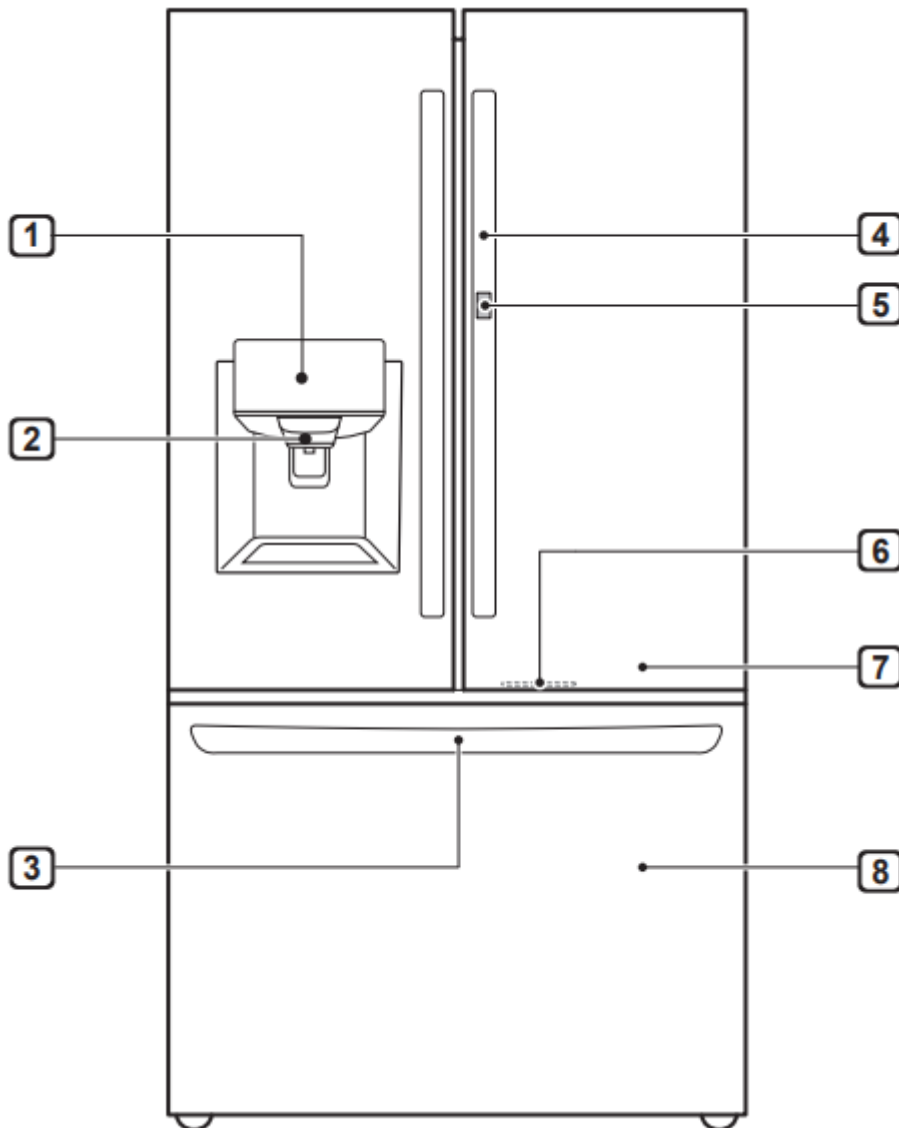

1. **Control Panel** Sets the refrigerator and freezer temperatures, the water filter condition and the dispenser mode.
2. **Filtered Water and Ice Dispenser** Dispenses purified water and ice.
3. **EZ Handle** Opens the freezer door easily.
4. **Handle Opens** and closes the refrigerator door.
5. **Door Button** Opens the Door-in-Door Compartment.

6. **LED Light** Lights up when the freezer door is opened.
7. **Refrigerator** Helps to preserve fresh food
8. **Freezer** Helps to preserve frozen food

## Interior

Standard Door : LFXS26973\*/LFXC22526\*

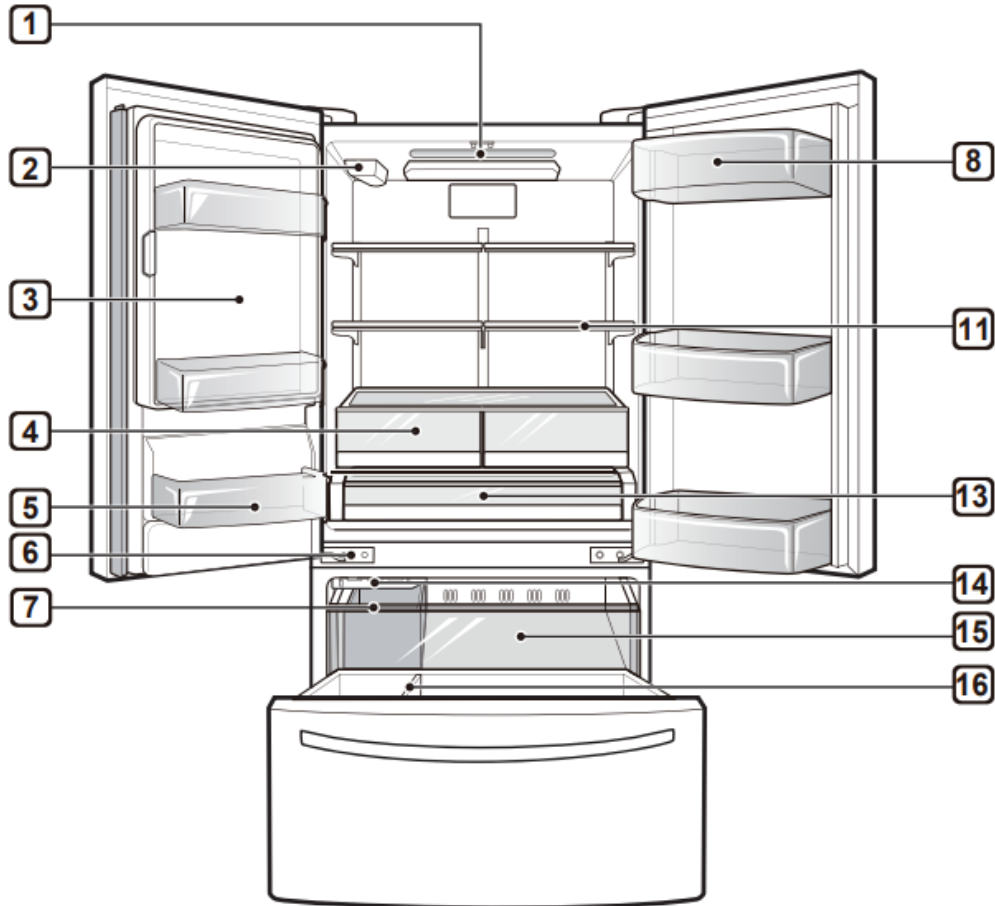

### 1. LED Interior Lighting

Lights up the inside of the refrigerator.

### 2. Water filter

Purifies water.

### 3. In-door Icemaker (Refrigerator)

Produces and stores ice automatically

### 4. Crisper

Helps vegetables and fruit to stay crisp.

### **Humidity Controlled Crisper (On Some Models)**

Helps vegetables and fruit to stay crisp and controls humidity.

5. Fixed Door

Bin Stores chilled food or drinks.

6. Auto-Closing Hinge (On Some Models)

Closes the refrigerator doors and freezer drawers automatically

7. Removable Ice Storage

Bin Stores ice for freezer icemaker.

8. Dairy Bin (On Some Models)

Stores milk products such as butter and cheese.

9. Door-in-Door Case

Store frequently used items that require easy access

10. Cheese & Butter and Condiment Bins (On Some Models)

Cheese & Butter and Condiment bins are specially designed for these items, making spreading butter and slicing cheese easier.

11. Adjustable Refrigerator Shelf

Adjusts shelves to meet individual storage needs.

12. Modular Door Bin (On Some Models)

Stores drinks such as juice and soda, as well as condiments, salad dressings and other food items.

13. Glide'N'Serve

Stores food items at a different temperature than the regular refrigerator area.

14. Automatic Icemaker (Freezer)

Produces and stores ice automatically in freezer compartment.

15. Pullout Drawer

Provides extra storage within the freezer compartment.

16. Durabase® and Durabase® Divider

Provides storage for large food items.

## INSTALLATION

### Installation Overview

Please read the following installation instructions first after purchasing this product or transporting it to another location.

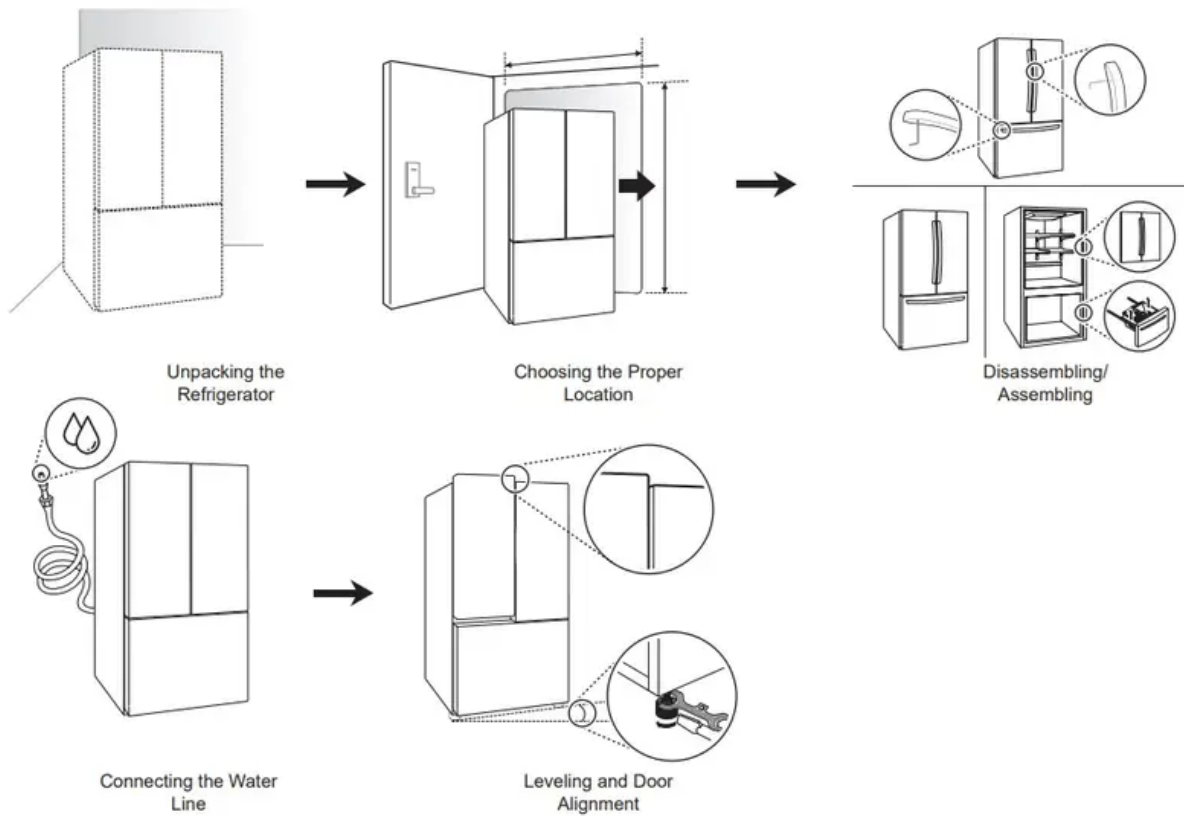

## Choosing the Proper Location

### Water

Must be located where a water supply can be connected for the automatic icemaker.

### Electricity

Use an individual, grounded outlet: 115 Volts, 60 Hz, AC, 15 Amps minimum.

### Flooring

To avoid noise and vibration, the unit must be installed and leveled on a solidly constructed floor. If required, adjust the leveling legs to compensate for the unevenness of the floor.

### Ambient Temperature

Install this appliance in an area where the temperature is between 55 °F (13 °C) and 110 °F (43 °C).

If the temperature around the appliance is too low or high, cooling ability may be adversely affected.

### Dimensions and Clearances

- Check the dimensions of the appliance and the installation path to ensure there is sufficient room to move the refrigerator through doors or narrow openings.
- If an opening is too narrow to fit the refrigerator through, remove the refrigerator doors. See Removing/ Assembling the Doors and Drawers in this manual

- The installation location chosen for the refrigerator should allow space behind the unit for connections and airflow and space in front to open the doors and drawers.
- Too small of a distance from adjacent items may result in lowered freezing capability and increased electricity consumption charges. Allow at least 24 inches (610 mm) in front of the refrigerator to open the doors, and at least 2 inches (50.8 mm) between the back of the refrigerator and the wall.

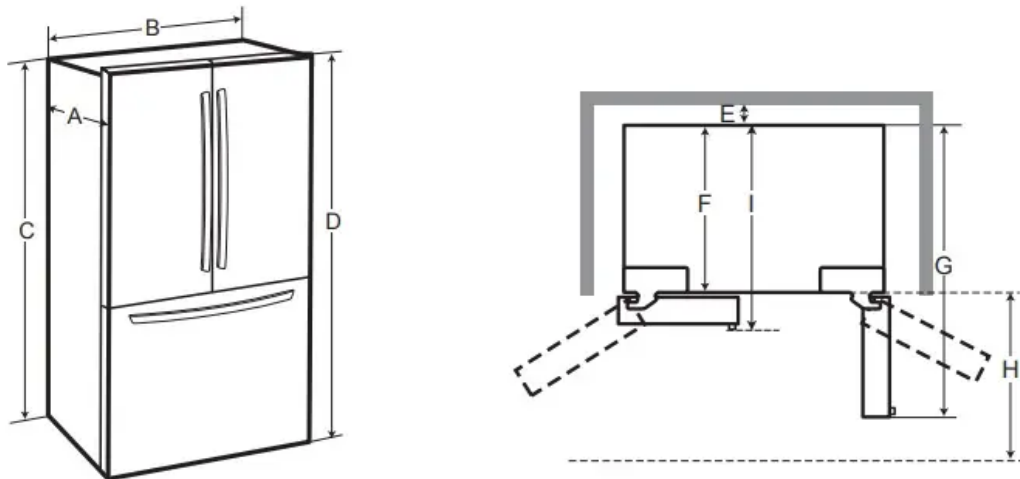

-	List	LFXC22526*	LFXS26973* LFXS26566*
A	Depth without handle	28 3/4" (728 mm)	32 3/8" (822 mm)
B	Width	35 3/4" (908 mm)	35 3/4" (908 mm)
C	Height to Top of Case	68 3/8" (1737 mm)	68 3/8" (1737 mm)
D	Height to Top of Hinge	69 3/4" (1772 mm)	69 3/4" (1772 mm)
E	Back Clearance	2" (50 mm)	2" (50 mm)
F	Depth without Door	24 3/4" (630 mm)	28 1/2" (724 mm)
G	Depth (Total with Door Open 90°)	43 1/2" (1103 mm)	47 1/8" (1197 mm)
H	Front Clearance	24" (610 mm)	24" (610 mm)
I	Depth With handle	31 1/4" (792 mm)	34 7/8" (886 mm)

## Removing/Assembling the Handles

### Removing the Refrigerator Handles

1. Loosen the set screws **1** with a 3/32 in. Allen wrench and remove the handle.
2. Loosen the mounting fasteners **2** that connect to the refrigerator door and handle using a 1/4 in. Allen wrench, and remove the mounting fasteners.



This function increases both ice making and freezing capabilities.

- Press the Ice Plus button to illuminate the icon and activate the function for 24 hours. The function automatically shuts off after 24 hours.
- Stop the function manually by pressing the button once more.

## 2. Smart Grid

Press the Smart Grid button to turn the Smart Grid function On/Off. When the function is on, the icon illuminates. The Smart Grid function automatically turns on when the refrigerator is connected to the Wi-Fi network.

When the refrigerator is responding to a Demand Response (DR) message from the electric company, the Grid text illuminates.

## 3. Freezer

Indicates the set temperature of the freezer compartment in Celsius (°C) or Fahrenheit (°F).

The default freezer temperature is 0°F (-18 °C). Press the Freezer button repeatedly to select a new set temperature from -6 °F to 8 °F (-21 °C to -13 °C).

## 4. Refrigerator

Temperature Indicates the set temperature of the refrigerator compartment in Celsius (°C) or Fahrenheit (°F).

The default refrigerator temperature is 37 °F (3 °C). Press the Refrigerator button repeatedly to select a new set temperature from 33 °F to 46 °F (1 °C to 8 °C).

### NOTE

- To change the temperature mode from °F to °C (or vice versa) press and hold the Refrigerator and Freezer Temperature buttons simultaneously for approximately five seconds. The temperature indicator on the display window switches between Celsius and Fahrenheit
- The displayed temperature is the target temperature, and not the actual temperature of the refrigerator. The actual refrigerator temperature depends on the food inside the refrigerator.

## 5. Fresh Air Filter

The Fresh Air Filter helps remove odors from the refrigerator. The Fresh Air Filter has two settings, Auto and Power. In Auto mode, the Fresh Air Filter cycles on and off in increments of ten minutes on and 110 minutes off. If set to the Power mode, the Fresh Air Filter stays on continuously for four hours, cycling on and off in increments of ten minutes on and five minutes off. After four hours, the Fresh Air Filter switches back to Auto mode.

- Press the Fresh Air Filter button repeatedly to toggle between Power mode and Auto mode.

## NOTE

- Replace the air filter when the Replace Filter icon turns on. After replacing the air filter, press and hold the Fresh Air Filter button for three seconds to turn the icon light off. Replace the air filter approximately every six months.
- Refer to the Replacing the Fresh Air Filter section for details.

## 6. \* Lock

The Lock function disables every other button on the display.

- When power is initially connected to the refrigerator, the Lock function is off.
- To lock the control panel buttons, press and hold the Lock button until the closed Lock icon  appears in the display and the function is activated.
- To disable the Lock function, press and hold the Lock button for approximately three seconds.

## 7. Water Filter

Replace the water filter when the Replace Filter icon turns on. After replacing the water filter, press and hold the Water Filter button for three seconds to turn the icon light off. Replace the water filter approximately every six months.

## 8. \* Wi-Fi

The Wi-Fi button, when used with the LG SmartThinQ app, allows the refrigerator to connect to a home Wi-Fi network. Refer to the Smart Functions section for information on the initial setup of the application.

The Wi-Fi icon shows the status of the refrigerator's network connection. The icon illuminates when the refrigerator is connected to the Wi-Fi network.

Press and hold the Wi-Fi button for 3 seconds to connect to the network. The icon blinks while the connection is being made, then turns on once the connection is successfully made.

## 3 and 8 SABBATH (On Some Models)

Sabbath mode is used on the Jewish Sabbath and holidays.

- To turn Sabbath mode on, touch the display to activate it, then press and hold the Freezer and Wi-Fi buttons for 3 seconds until Sb appears in the display.
- Sabbath mode automatically turns off after 96 hours.
- To turn Sabbath mode off manually, press and hold the Freezer and Wi-Fi buttons for 3 seconds.
- Once turned on, Sabbath mode is maintained even after a power outage.
- Selecting Sabbath mode automatically turns off the Alarm functions. The dispenser and InstaView function are disabled.

## 9. Dispenser Mode

Press the buttons to select cubed ice, water, or crushed ice. The LED illuminates over the mode selected.

## Ice Compartment

Keep the ice compartment door closed tightly. If the ice compartment door is not closed tightly, the cold air in the ice bin will freeze food in the refrigerator compartment. This could also cause the icemaker to stop producing ice.

## In-Door Ice Bin

The icemaker stops producing ice when the in-door ice bin is full.

During use, the ice may stack unevenly in the bin, causing the icemaker to misread the number of ice cubes and stop producing ice. Shaking the ice bin to level the ice within it can reduce this problem.

To prevent ice cubes from melting and leaking from the dispenser, ALWAYS empty the ice bin when the icemaker is turned OFF for more than a few hours.

The ice passage may become blocked with frost if only crushed ice is used. Remove the frost that accumulates by removing the ice bin and clearing the passage with a rubber spatula. Dispensing cubed ice can also help prevent frost buildup.

## Detaching the In-Door Ice Bin

1 Gently pull the handle to open the ice compartment.

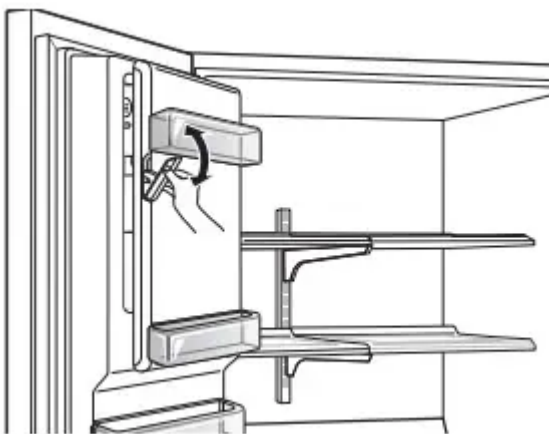

2 To remove the in-door ice bin, grip the front handle, slightly lift the lower part, and slowly pull out the bin as shown.

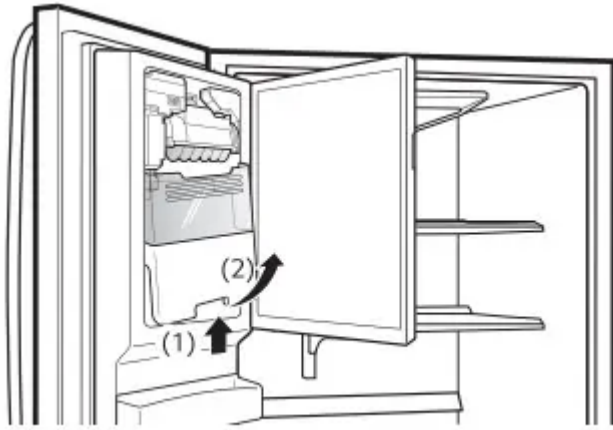

### Assembling the In-Door Ice Bin

- 1 Carefully insert the in-door ice bin, slanting the top slightly to fit it under the icemaker.

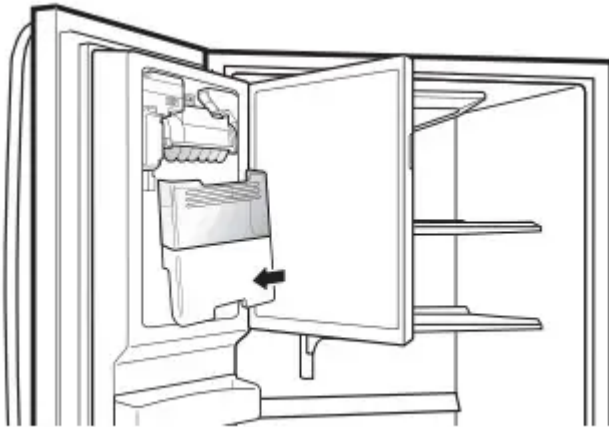

- 2 Gently push the handle to close the ice compartment.

### Automatic Icemaker

#### In-Door Icemaker

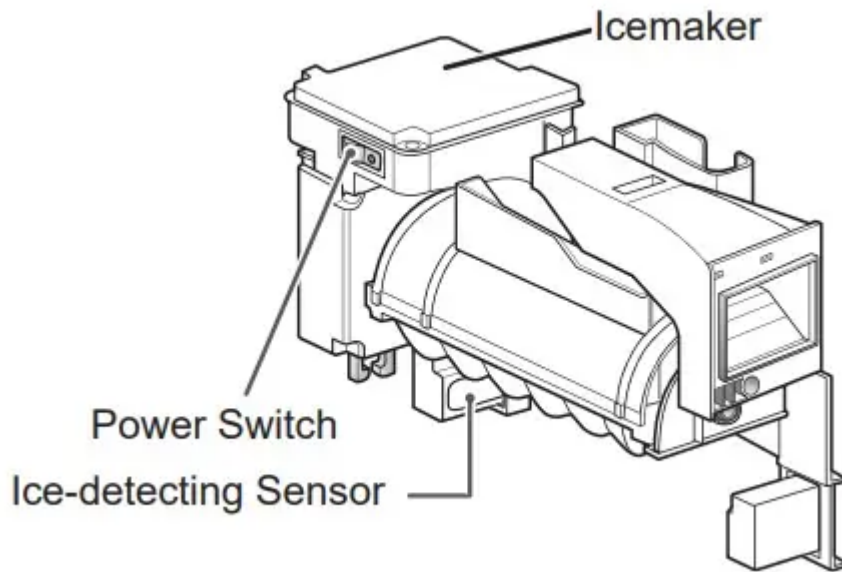

**NOTE**

- Ice is made in the automatic in-door icemaker and sent to the dispenser. The icemaker produces 70 - 182 cubes in a 24-hour period, depending on freezer compartment temperature, room temperature, number of door openings and other operating conditions.
- It takes about 12 to 24 hours for a newly installed refrigerator to begin making ice.
- Ice-making stops when the in-door ice bin is full. When full, the in-door ice bin holds approximately 6 to 8 (12-16 oz.) glasses of ice.
- Foreign substances or frost on the ice-detecting sensor can interrupt ice production. Make sure the sensor area is clean at all times for proper operation.
- To increase ice production, use the Ice Plus function. The function increases both ice making and freezing capabilities.

**Freezer Icemaker**

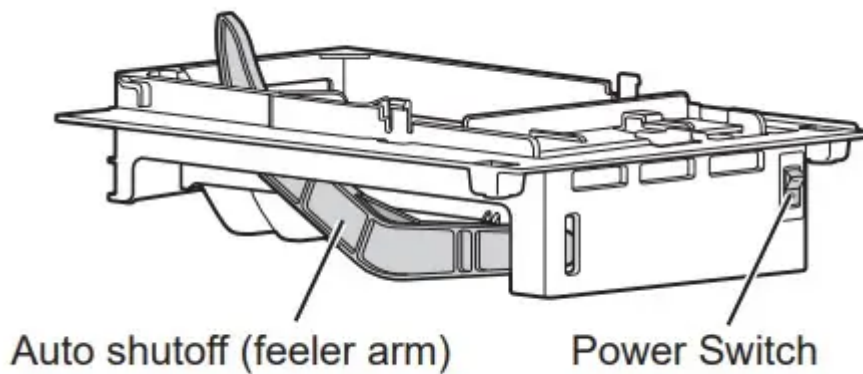

## NOTE

- The automatic freezer icemaker produces 12 cubes at a time, 50-110 pieces within a 24 hour period if conditions are favorable. This amount may vary according to the environment (ambient temperature around the appliance, frequency of the door being opened, amount of food stored in the appliance, etc.).
- If the ice bin is completely filled with ice, ice production will stop.
- Sound of ice dropping into the ice bin is normal.
- The icemaker produces ice once approximately 48 hours have passed after the appliance is initially installed.
- Discard the first ice cubes produced after initial install.
- Ice cubes which are stored in the ice bin for a long time may clump together and be difficult to separate. If this happens, empty the ice bin completely and clean it before reinstalling it.

### **Turning the Automatic Icemakers On or Off**

To turn off one of the automatic icemakers, set the icemaker switch to OFF (O). To turn on the automatic icemaker, set the switch to ON (I).

### **Normal Sounds You May Hear**

- Keeping the power turned on to the icemakers before the water line is connected can damage the icemakers.
- The icemaker water valve will buzz as the icemaker fills with water. If the power switch is in the ON (I) position, it will buzz even if it has not yet been hooked up to water. To stop the buzzing, move the power switch to OFF (O).
- You will hear the sound of cubes dropping into the bin and water running in the pipes as the icemaker refills.

## **MAINTENANCE**

### **Cleaning**

#### **General Cleaning Tips**

- Both the refrigerator and freezer sections defrost automatically; however, clean both sections once a month to prevent odors.
- Wipe up spills immediately.
- Unplug the refrigerator or disconnect power before cleaning.
- Remove all removable parts, such as shelves.

- Use a clean sponge or soft cloth and a mild detergent in warm water. Do not use abrasive or harsh cleaners.
  - Hand wash, rinse and dry all surfaces thoroughly.
  - When cleaning the inside or outside of the appliance, do not wipe it with a rough brush, toothpaste, or flammable materials. Do not use cleaning agents containing flammable substances.
- This may cause discoloration or damage to the appliance.
- Flammable substances: alcohol (ethanol, methanol, isopropyl alcohol, isobutyl alcohol, etc.), thinner, bleach, benzene, flammable liquid, abrasive, etc.

### **Exterior**

- Waxing external painted metal surfaces helps provide rust protection. Do not wax plastic parts. Wax painted metal surfaces at least twice a year using appliance wax (or auto paste wax). Apply wax with a clean, soft cloth.
- For products with black stainless steel exterior, spray glass cleaner on a clean, microfiber cloth and rub in direction of grain. Do not spray glass cleaner directly at the display panel. Do not use harsh or abrasive cleaners.
- For products with a standard stainless steel exterior, use a damp microfiber cloth and rub in the direction of the grain. Dry with a paper towel to avoid streaks. For stubborn stains and fingerprints, use a few drops of liquid dish soap in water, and rinse with hot water before drying. Do not use abrasive or harsh cleaners.

### **Inside Walls**

- Allow freezer to warm up so the cloth will not stick.

To help remove odors, wash the inside of the refrigerator with a mixture of baking soda and warm water. Mix 2 tablespoons of baking soda to 1 quart of water (26 g soda to 1 liter water.) Be sure the baking soda is completely dissolved so it does not scratch the surfaces of the refrigerator.

### **Door Liners and Gaskets**

- Use a clean sponge or soft cloth and a mild detergent in warm water. Do not use cleaning waxes, concentrated detergents, bleaches, or cleaners containing petroleum on plastic refrigerator parts.

### **Plastic Parts (Covers and Panels)**

- Use a clean sponge or soft cloth and a mild detergent in warm water. Do not use glass cleaners, abrasive cleansers, or flammable fluids. These can scratch or damage the material.

## Condenser Coils

- Use a vacuum cleaner with a brush or crevice attachment to clean the condenser cover and vents. Do not remove the panel covering the condenser coil area.

# TROUBLESHOOTING

## FAQs

### Frequently Asked Questions

Q: What are the best temperature settings for my refrigerator and freezer?

A: The default setting for the refrigerator is 37° Fahrenheit (3° Celsius). The default setting for the freezer is 0° Fahrenheit (-18° Celsius). Adjust these settings as necessary to keep food at desired temperatures. Milk should be cold when stored on the inner shelf of the refrigerator. Ice cream should be firm and ice cubes should not melt in the freezer. To switch the display from Fahrenheit to Celsius, press and hold the Freezer and Refrigerator buttons until you hear a beep and the settings in the display change.

Q: How do I set the refrigerator and freezer temperatures?

A: Continually press the Refrigerator or Freezer button on the control panel until the desired temperature appears. The numbers will cycle from highest to lowest and then return to the highest again with continuous pressing.

Q: Why do I hear a buzzing noise from my refrigerator periodically?

A: This may happen if you do not have a water source attached to your refrigerator and the icemaker is turned on. If you do not have a water source attached to the back of the refrigerator you should turn the icemaker off.

Q: Why does the icemaker tray look crooked?

A: This is a normal part of the icemaker cycle. The icemaker tray may appear level or with a slight tilt. The change in position is to assist in the freezing process.

Q: My refrigerator is powered on and the controls are working, but it's not cooling and the display shows "OFF" (see below). What is wrong?

A: The refrigerator is in Display Mode. The Display Mode disables all cooling in the refrigerator and freezer sections to conserve energy while on display in a retail store. When activated, OFF is displayed on the control panel and the display remains on for 20 seconds. With either refrigerator door opened, press the Ice Plus button 3 times consecutively while pressing the Refrigerator button. The control panel beeps and the temperature settings display to confirm that Display Mode is deactivated. Use the same procedure to activate Display Mode.

## Cooling

Refrigerator and Freezer section are not cooling.

- The refrigerator control is set to OFF (some models).
  - Turn the control ON. Refer to the Setting the Controls section for proper temperature settings.
- Refrigerator is set to Demo Mode.
  - Demo Mode allows the lights and control display to work normally while disabling cooling, to save energy while the refrigerator is on the showroom floor. See the FAQs section of this manual for instructions on how to disable Demo Mode.
- Refrigerator is in the defrost cycle.
  - During the defrost cycle, the temperature of each compartment may rise slightly. Wait 30 minutes and confirm the proper temperature has been restored once the defrost cycle has completed.
- Refrigerator was recently installed.
  - It may take up to 24 hours for each compartment to reach the desired temperature.
- Refrigerator was recently relocated.
  - If the refrigerator was stored for a long period of time or moved on its side, it is necessary for the refrigerator to stand upright for 24 hours before connecting it to power.

Cooling system runs too much.

- Refrigerator is replacing an older model.
  - Modern refrigerators require more operating time but use less energy due to more efficient technology.
- Refrigerator was recently plugged in or power restored.
  - The refrigerator will take up to 24 hours to cool completely
- The door is opened often or a large amount of food / hot food was added.
  - Adding food and opening the door warms the refrigerator, requiring the compressor to run longer in order to cool the refrigerator back down. In order to conserve energy, try to get everything you need out of the refrigerator at once, keep food organized so it is easy to find, and close the door as soon as the food is removed. (Refer to the Food Storage Guide.)

- Doors are not closed completely.
  - Firmly push the doors shut. If they will not shut all the way, the "Doors will not close correctly or pop open" section in Troubleshooting.
- Refrigerator is installed in a hot location.
  - The compressor will run longer under warm conditions. At normal room temperatures (70 °F or 21 °C) expect your compressor to run about 40 % to 80 % of the time. Under warmer conditions, expect it to run even more often. The refrigerator should not be operated above 110 °F (43 °C).
- Condenser / back cover is clogged.
  - Use a vacuum cleaner with an attachment to clean the condenser cover and vents. Do not remove the panel covering the condenser coil area.

#### Interior moisture buildup

- Doors are opened often or for long periods of time.
  - When the doors are opened often or for long periods of time, warm, humid air enters the compartment. This raises the temperature and moisture level within the compartment. To lessen the effect, reduce the frequency and duration of door openings.
- Doors are not closed correctly.
  - See the "Doors will not close correctly or pop open" section
- Weather is humid.
  - Humid weather allows additional moisture to enter the compartments when the doors are opened leading to condensation or frost. Maintaining a reasonable level of humidity in the home will help to control the amount of moisture that can enter the compartments.
- Defrost cycle recently completed.
  - During the defrost cycle, the temperature of each compartment may rise slightly and condensation may form on the back wall. Wait 30 minutes and confirm that the proper temperature has been restored once the defrost cycle has completed.
- Food is not packaged correctly.
  - Food stored uncovered or unwrapped, and damp containers can lead to moisture accumulation within each compartment. Wipe all containers dry and store food in sealed packaging to prevent condensation and frost.

Food is freezing in the refrigerator compartment.

- Food with high water content was placed near an air vent.
  - Rearrange items with high water content away from air vents.
- Refrigerator temperature control is set incorrectly.
  - If the temperature is too cold, adjust the control one increment at a time and wait for the temperature to stabilize. Refer to the Control Panel section for more information.
- Refrigerator is installed in a cold location.
  - When the refrigerator is operated in temperature below 41 °F (5 °C), food can freeze in the refrigerator compartment. The refrigerator should not be operated in temperature below 55 °F (13 °C).

Refrigerator or Freezer section is too warm.

- Refrigerator was recently installed.
  - It may take up to 24 hours for each compartment to reach the desired temperature.
- The air vents are blocked. Cold air circulates from the freezer to the fresh food section and back again through air vents in the wall dividing the two sections.
  - Locate air vents by using your hand to sense airflow and move all packages that block vents and restrict airflow. Rearrange items to allow air to flow throughout the compartment.
- Doors are opened often or for long periods of time.
  - When the doors are opened often or for long periods of time, warm, humid air enters the compartment. This raises the temperature and moisture level within the compartment. To lessen the effect, reduce the frequency and duration of door openings.
- Unit is installed in a hot location.
  - The refrigerator should not be operated in temperatures above 110 °F (43 °C).
- A large amount of food or hot food was added to either compartment.
  - Adding food warms the compartment requiring the cooling system to run. Allowing hot food to cool to room temperature before putting it in the refrigerator will reduce this effect.
- Doors are not closed correctly.
  - See the "Doors will not close correctly or pop open" section in the Troubleshooting.

- Temperature control is not set correctly.
  - If the temperature is too warm, adjust the control one increment at a time and wait for the temperature to stabilize.
- Defrost cycle has recently completed.
  - During the defrost cycle, the temperature of each compartment may rise slightly and condensation may form on the back wall. Wait 30 minutes and confirm the proper temperature has been restored once the defrost cycle has completed.

Refrigerator or Freezer section is too cold.

- Incorrect temperature control settings.
  - If the temperature is too cold, adjust the control one increment at a time and wait for the temperature to stabilize. Refer to the Control Panel for more information.

Frost or ice crystals form on frozen food (inside of sealed package).

- Condensation from food with a high water content has frozen inside of the food package.
  - This is normal for food items with a high water content.
- Food has been left in the freezer for a long period of time.
  - Do not store food items with high water content in the freezer for a long period of time.

Frost or ice crystals form on frozen food (outside of package).

- Door is opened frequently or for long periods of time.
  - When the doors are opened often or for long periods of time, warm, humid air enters the compartment. This raises the temperature and moisture level within the compartment. Increased moisture will lead to frost and condensation. To lessen the effect, reduce the frequency and duration of door openings.
- Door is not closing properly.
  - Refer to the "Doors will not close correctly or pop open" section in the Troubleshooting.

## Ice & Water

Icemaker is not making enough ice.

- Demand exceeds ice storage capacity.
  - The icemaker will produce approximately 70-184 cubes in a 24 hour period.

- House water supply is not connected, valve is not turned on fully, or valve is clogged.
  - Connect the refrigerator to a cold water supply with adequate pressure and turn the water shutoff valve fully open. If the problem persists, it may be necessary to contact a plumber.
- Water filter has been exhausted.
  - Replacing the water filter is recommended: Approximately every six months. When the water filter indicator turns on. When the water dispenser output decreases. When the ice cubes are smaller than normal.
- Low house water supply pressure.
  - The water pressure must be between 20 and 120 psi on models without a water filter and between 40 and 120 psi on models with a water filter. If the problem persists, it may be necessary to contact a plumber.
- Reverse osmosis filtration system is used.
  - Reverse osmosis filtration systems can reduce the water pressure below the minimum amount and result in icemaker issues. (Refer to the Connecting the Water Line section.)
- Tubing connecting refrigerator to house supply valve is kinked.
  - The tubing can kink when the refrigerator is moved during installation or cleaning resulting in reduced water flow. Straighten or repair the water supply line and arrange it to prevent future kinks.
- Doors are opened often or for long periods of time.
  - If the doors of the unit are opened often, ambient air will warm the refrigerator which will prevent the unit from maintaining the set temperature. Lowering the refrigerator temperature can help, as well as not opening the doors as frequently.
- Doors are not closed completely.
  - If the doors are not properly closed, ice production will be affected. See the "Doors will not close correctly or pop open" section in Parts & Features Troubleshooting for more information.
- The temperature setting for the freezer is too warm.
  - The recommended temperature for the freezer compartment for normal ice production is 0°F. If the freezer temperature is warmer, ice production will be affected.

## Icemaker is not making ice

- Refrigerator was recently installed or icemaker recently connected.
  - It may take up to 24 hours for each compartment to reach the desired temperature and for the icemaker to begin making ice.
- Icemaker is not turned on.
  - Locate the icemaker ON/OFF and confirm that it is turned on.
- The ice detecting sensor is obstructed.
  - Foreign substances or frost on the ice-detecting sensor can interrupt ice production. Make sure that the sensor area is clean at all times for proper operation.
- The refrigerator is not connected to a water supply or the supply shutoff valve is not turned on.
  - Connect the refrigerator to the water supply and turn the water shutoff valve fully open
- Icemaker shutoff (arm or sensor) obstructed.
  - If your icemaker is equipped with an ice shutoff arm, make sure that the arm moves freely. If your icemaker is equipped with the electronic ice shutoff sensor, make sure that there is a clear path between the two sensors.
- Reverse osmosis water filtration system is connected to your cold water supply.
  - Reverse osmosis filtration systems can reduce the water pressure below the minimum amount and result in icemaker issues. (Refer to the Connecting the Water Line section.)

## Ice has bad taste or odor.

- Water supply contains minerals such as sulfur.
  - A water filter may need to be installed to eliminate taste and odor problems. NOTE: In some cases, a filter may not help. It may not be possible to remove all minerals/odor/taste in all water supplies.
- Icemaker was recently installed.
  - Ice that has been stored for too long will shrink, become cloudy, and may develop a stale taste. Throw away old ice and make a new supply.
- The food has not been stored properly in either compartment.
  - Rewrap the food. Odors may migrate to the ice if food is not wrapped properly.

- The interior of the refrigerator needs to be cleaned.
  - See the Maintenance section for more information.
- The ice storage bin needs to be cleaned.
  - Empty and wash the bin (discard old cubes). Make sure that the bin is completely dry before reinstalling it

Icemaker is making too much ice.

- Icemaker shutoff (arm/ sensor) is obstructed.
  - Empty the ice bin. If your icemaker is equipped with an ice shutoff arm, make sure that the arm moves freely. If your icemaker is equipped with the electronic ice shutoff sensor, make sure that there is a clear path between the two sensors. Reinstall the ice bin and wait 24 hours to confirm proper operation.

## Parts & Features

Doors will not close correctly or pop open

- Food packages are blocking the door open.
  - Rearrange food containers to clear the door and door shelves.
- Ice bin, crisper cover, pans, shelves, door bins, or baskets are out of position.
  - Push bins all the way in and put crisper cover, pans, shelves and baskets into their correct positions. See the Operation section for more information.
- The doors were removed during product installation and not properly replaced.
  - Remove and replace the doors according to the Removing and Replacing Refrigerator Handles and Doors section.
- Refrigerator is not leveled properly.
  - See Door Alignment in the Refrigeration Installation section to level refrigerator.

Doors are difficult to open

- The gaskets are dirty or sticky.
  - Clean the gaskets and the surfaces that they touch. Rub a thin coat of appliance polish or kitchen wax on the gaskets after cleaning
- Door was recently closed.
  - When you open the door, warmer air enters the refrigerator. As the warm air cools, it can create a vacuum. If the door is hard to open, wait one minute to allow the air pressure to equalize, then see if it opens more easily.

Refrigerator wobbles or seems unstable

- Leveling legs are not adjusted properly.
  - Refer to the Leveling and Door Alignment section.
- Floor is not level.
  - It may be necessary to add shims under the leveling legs or rollers to complete installation

Lights do not work.

- LED interior lighting failure.
  - The refrigerator compartment lamp is LED interior lighting, and service should be performed by a qualified technician.

Refrigerator has an unusual odor.

- The Air Filter may need to be set to the MAX setting or replaced.
  - Set the Air Filter to the MAX setting. If the odor does not go away within 24 hours, the filter may need to be replaced. See the Replacing the Air Filter section for replacement instructions.

The interior of the refrigerator is covered with dust or soot.

- The refrigerator is located near a fire source, such as a fireplace, chimney, or candle.
  - Make sure that the refrigerator is not located near a fire source, such as a fireplace, chimney or candle.

## Noises

Clicking

- The defrost control will click when the automatic defrost cycle begins and ends. The thermostat control (or refrigerator control on some models) will also click when cycling on and off.
  - Normal Operation

Rattling

- Rattling noises may come from the flow of refrigerant, the water line on the back of the unit, or items stored on top of or around the refrigerator.
  - Normal Operation
- Refrigerator is not resting solidly on the floor.
  - Floor is weak or uneven or leveling legs need to be adjusted. See the Leveling and Door Alignment section.

- Refrigerator with linear compressor was jarred while running.
  - Normal Operation

#### Whooshing

- Evaporator fan motor is circulating air through the refrigerator and freezer compartments.
  - Normal Operation
- Air is being forced over the condenser by the condenser fan.
  - Normal Operation

#### Gurgling

- Refrigerant flowing through the cooling system.
  - Normal Operation

#### Popping

- Contraction and expansion of the inside walls due to changes in temperature.
  - Normal Operation

#### Sizzling

- Water dripping on the defrost heater during a defrost cycle.
  - Normal Operation

#### Vibrating

- If the side or back of the refrigerator is touching a cabinet or wall, some of the normal vibrations may make an audible sound.
  - To eliminate the noise, make sure that the sides and back cannot vibrate against any wall or cabinet.

#### Dripping

- Water running into the drain pan during the defrost cycle
  - Normal Operation

#### Pulsating or highpitched sound

- Your refrigerator is designed to run more efficiently to keep your food items at the desired temperature. The high efficiency compressor may cause your new refrigerator to run longer than your old one, but it is still more energy efficient than previous models. While the refrigerator is running, it is normal to hear a pulsating or highpitched sound.
  - Normal Operation

#### Wi-Fi Network

Your home appliance and smartphone is not connecting to the Wi-Fi network.

- The password for the Wi-Fi that you are trying to connect to is incorrect.
  - Find the Wi-Fi network connected to your smartphone and remove it, then register your appliance on LG SmartThinQ application.
- Mobile data for your smartphone is turned on.
  - Turn off the Mobile data on your smartphone before registering the appliance.
- The wireless network name (SSID) is set incorrectly.
  - The wireless network name (SSID) should be a combination of English letters and numbers. (Do not use special characters.)
- The router frequency is not 2.4 GHz.
  - Only a 2.4 GHz router frequency is supported. Set the wireless router to 2.4 GHz and connect the appliance to the wireless router. To check the router frequency, check with your Internet service provider or the router manufacturer.
- The router is too far from the appliance.
  - If the appliance is too far from the router, the signal may be weak and the connection may not be configured correctly. Move the router closer to the appliance or purchase and install a Wi-Fi repeater.

### **Warning**

This content is compiled from multiple sources and is provided for reference purposes only. It may not be complete or fully applicable to all situations. If you are unable to resolve your issue, please contact the product manufacturer or an authorized service provider for official support.