

DESCRIPTION OF YOUR APPLIANCE

Pyro clean programmable electric oven

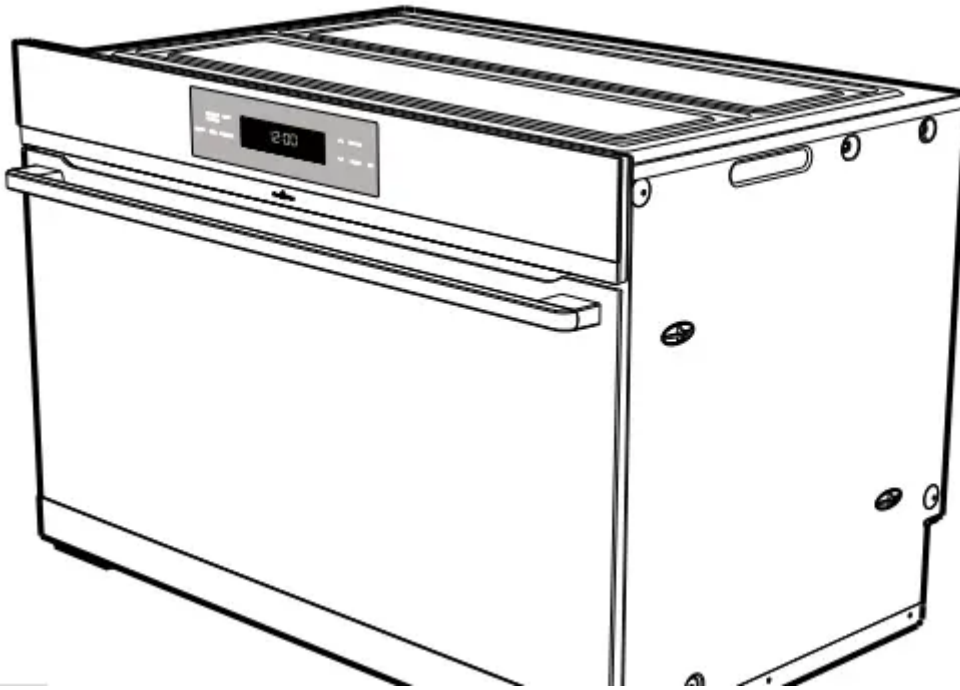

Control Panel

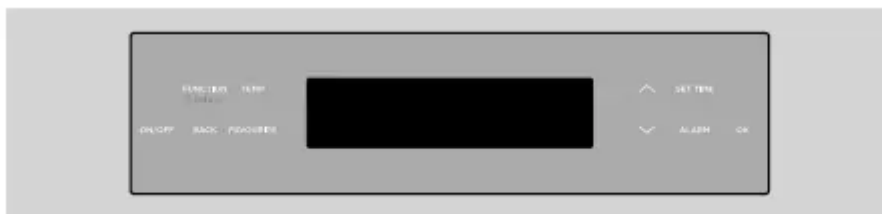

INSTALLATION OF THE APPLIANCE

Cabinet requirement

Models are designed to be built into cabinetry either below a benchtop or into a vertical cabinet.

WARNING

- The cooker must be installed and serviced only by an authorised person.
- A Certificate of Compliance MUST be supplied to be kept by the customer.
- The packing materials must be removed before you install the cooker.

- The surrounding kitchen cabinets must be able to withstand 85°C. Electrolux WILL NOT accept responsibility for damage caused by installation into kitchen cabinets which cannot withstand 85°C.
- The vents, openings and air spaces MUST NOT be blocked.
- You MUST NOT lift or pull the cooker by the door handle.
- The cooker MUST be checked every five years.
- If the supply cord is damaged, it must be replaced by the manufacturer, its service agent or similarly qualified persons in order to avoid a hazard.
- The appliance must not be installed behind a decorative door in order to avoid overheating.
- Due to the weight (70kg) and size of the cooker, persons are required to install it.

IMPORTANT To minimise the weight of the oven for easier installation, remove the oven door and oven internal accessory pack.

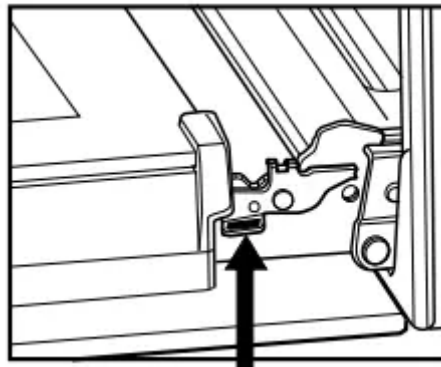

Locking tab up at normal position.

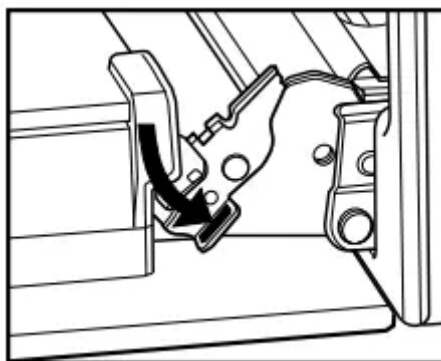

Press the locking tab down for removing the door.

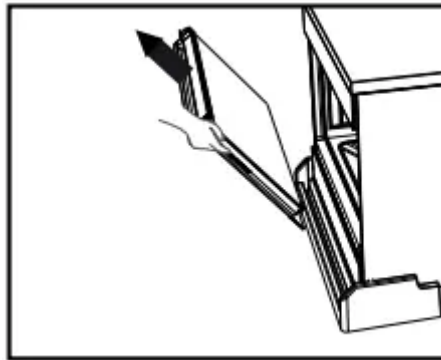

Gently close the door until it comes to a stop. Then lift the door on the hinge.

Leveling oven

Place a level in the oven as below making sure the level sits on the front and rear forms.

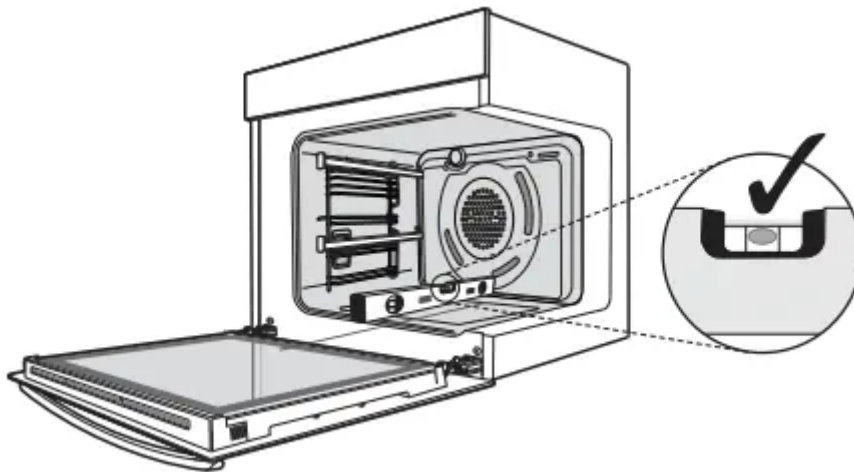

Underbench installation

Your underbench oven looks best when the control panel is directly under the benchtop. An upper infill panel may be added if the cooktop placed above the benchtop is too deep.

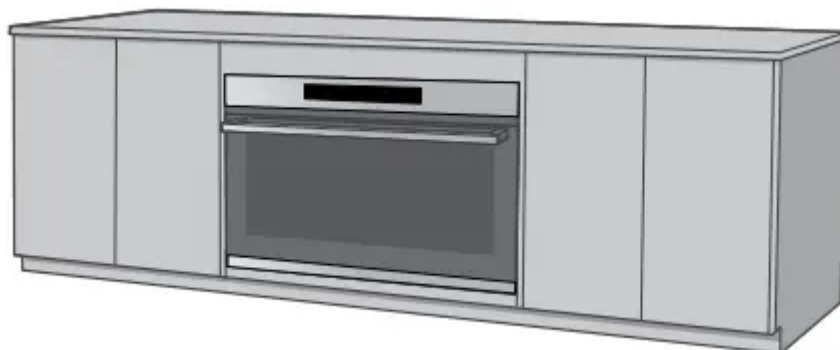

Vertical cabinet installation

The oven can be built into a vertical cabinet in the same manner as an underbench. The required cavity dimensions are the same and the product is secured to the cabinet in the same way



Oven dimensions

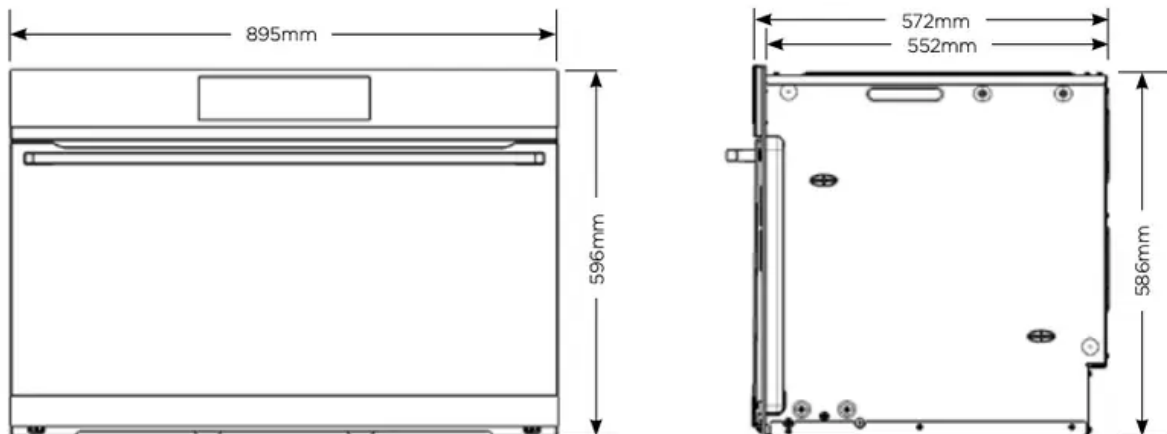

Cabinet construction for built in oven

For the best integration within a kitchen, install this appliance in a cupboard that gives a flush fit with the surrounding cupboard fronts. A recess of 20mm is ideal.

NOTE: Your appliance must be mounted on a horizontal surface for the full width and depth of the product.

NOTE: A ventilation slot 20mm wide is required at the rear of the base of the cabinet floor.

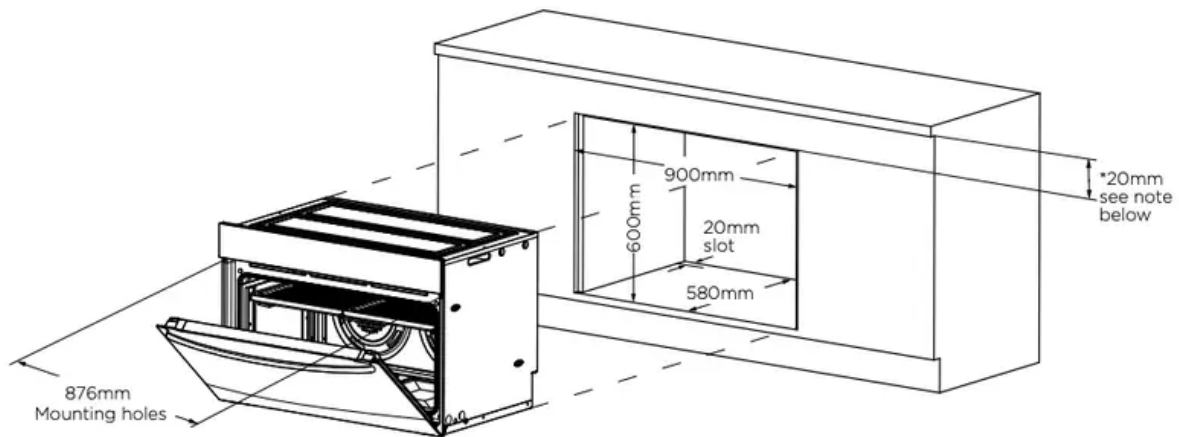
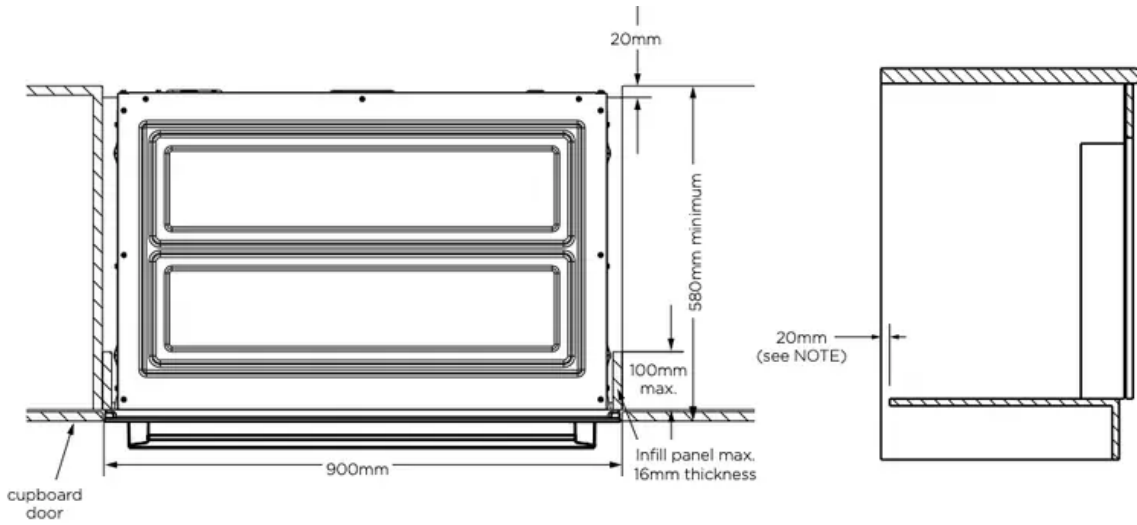

NOTE: If a powerpoint is fitted it must be accessible with the appliance installed.

*Refer to cooktop installation instructions for required clearance between cooktop and oven.

WIRING REQUIREMENTS

The cooker **MUST** be installed in compliance with:

- Wiring connections in AS/NZS 3000 Wiring Rules.
- Local regulations, municipal building codes and other statutory regulations.

The Data plate gives information about rating and is located behind the bottom of the oven door.

- A functional switch **MUST** be provided near the appliance in an accessible position (AS/ NZS 3000 - Clause 4.7.1).

- Wiring MUST be protected against mechanical failure (AS/NZS 3000 - Clause 3.9).
- Disconnection in the fixed wiring must occur in accordance with the AS/NZS 3000 wiring rules.
- The cooker MUST be properly earthed.
- This range must be connected with cable of 75°C rating minimum.
- This product has passed the insulation resistance test after manufacture. If the resistance reading is low at installation, it is probably caused by moisture from the atmosphere being absorbed by the elements after the range has been produced. (pass at 0.01 M AS/NZS 3000 Wiring Rules Clause 8.3.6.2).

Note: When connections are made to a multi-phase 230/240V supply, the bridge piece MUST be removed from between the active connections.

Connecting to services and commissioning

This appliance must be installed by an authorised person, according to all codes and regulations of:

- ELECTRICAL supply authorities.
- Building regulations.
- Local government and council authorities.
- AS/NZS 5601.1 (particular attention to clause 6.10.1, including figure 6.3 and subclause 6.10.1.11).
- AS/NZS 3000 (particular attention to clauses 4.7.1 and 3.9).

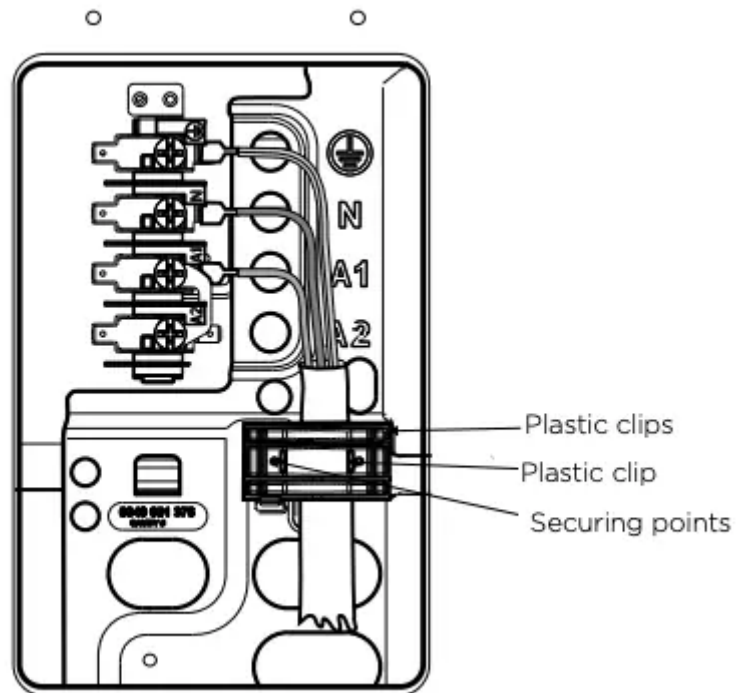

Hard wiring detail

1. Remove terminal cover plate from rear panel of appliance.
2. Fit wires through hole in back panel below terminal cover.
3. Engage wires into plastic clip. Secure plastic clip with two long silver screws (supplied in separate bag).
4. Replace cover plate onto rear panel.

Electrical connection location - built-in models

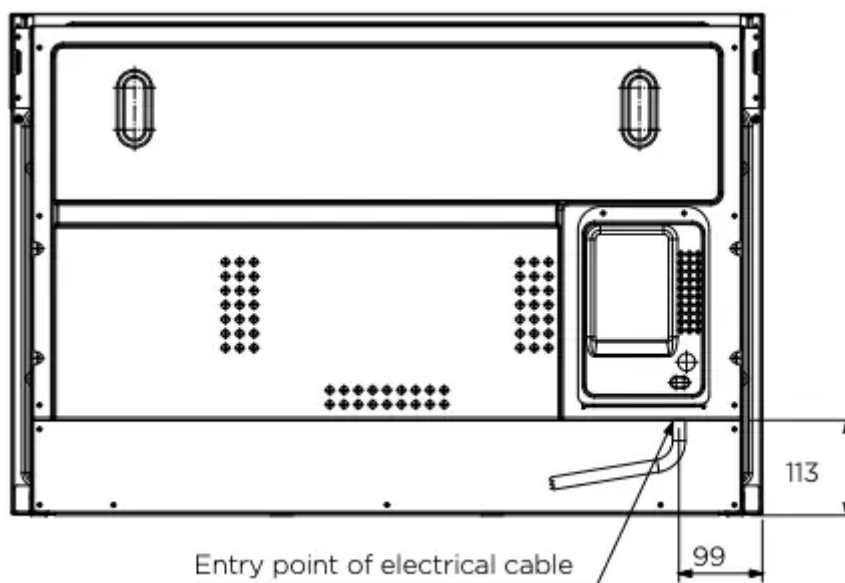

BEFORE OPERATING YOUR APPLIANCE FOR THE FIRST TIME

Preparing your appliance for the first time

- Please remove all internal boxes and bags from the oven before operation.
- Please wipe out the oven interior prior to operation with warm soapy water and polish dry with a soft clean cloth. Do not close the oven door until the oven is completely dry.
- New appliances can have an odour during first operation. It is recommended to 'run in' your oven before you cook for the first time. Run the oven at 180°C for 2 hours and ensure that the room is well ventilated.
- DO NOT line the oven with foil, it will damage the enamel.
- Prior to installing accessories, remove all packaging and remove plastic film from external panels.



Setting the time

After electrically connecting the appliance, you must set the time of the day before you can operate your oven.

WVEP917DSC electronic controller



When you connect the appliance to the mains, or reconnect after a power cut, the display contrast, the display brightness and the time of day all need to be set.

1. Press  or  to set the value.
2. Press OK to confirm

USING YOUR OVEN

Understanding your oven functions

Rapid Heat/AirFry

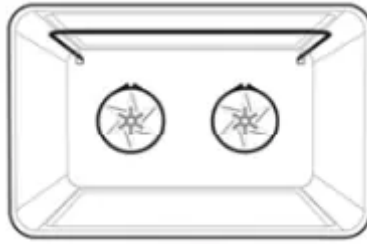

This function can be either used for a quicker pre-heat of your oven or used to turn your oven into an AirFry for your frying needs. Heat comes from the elements surrounding the fans as well as the smaller element above the food. This will heat up your oven 30% faster.

Selected models are provided with an AirFry. The AirFry enables advanced convection cooking without having to turn the food, giving crispy great tasting results in a shorter time without all the oil. This is suitable for chips, chicken wings, nuggets and similar products.

Food items should be placed onto the mesh tray, spread out evenly and positioned in the middle of the oven. Set the function to AirFry and set the temperature as recommended.

Fan Forced/Fan Bake

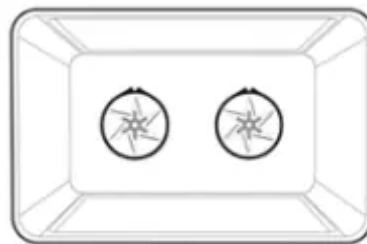

Heat comes from the elements surrounding the fans. The fans circulate the hot air around the oven cavity so that you can put your food in different places in the oven and still cook them at the same time. You can use the “Fan Force” function for multi-shelf cooking, reheating cooked foods, pastries and complete oven meals. It will cook at a lower temperature and be faster than baking. Please note that some variation in browning is normal.

Easy Bake Steam (WVEP917DSC model only)



Easy Bake Steam adds humidity at the beginning of the baking process. In bakery products, this allows the dough to rise and helps create a moist interior while obtaining a golden and crispy crust. Before preheating, when the oven is cold, add water to the cavity well. Refer to chapter ‘Easy Bake Steam’ for more details. For best results preheat the empty oven for 10 minutes prior to inserting food.

Bake/Pizza



Heat comes from two elements, one above and one below the food. The bottom element is a clean heat element and is below the floor of the oven. Both elements are controlled by the thermostat and will turn on and off to maintain the set temperature. You can use the “Bake/Pizza” function for pizza and single trays of biscuits, scones, muffins, cakes, slices, casseroles, baked puddings, roasts and delicate egg dishes.

Base Heat

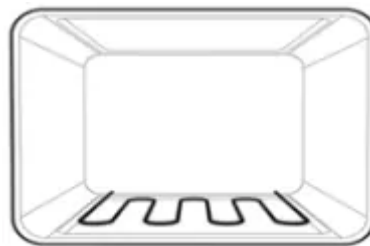

Heat comes from the element below the floor of the oven. The Element is controlled by the thermostat and will turn on and off to maintain the set temperature. The “Base Heat” function can be used to add extra browning to the bases of pizzas, pies and pastries. Cook in the lower half of the oven when you are using only one shelf. For best results, use silver or shiny trays.

Fan Assist

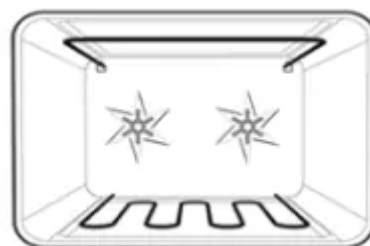

Heat comes from two elements, one above and one below the food. The fans circulate the hot air around the oven cavity so that you can put the food in different places in the oven and still cook them at the same time. You should only use a maximum of 2 shelves with “Fan Assist”. Do not use the bottom shelf. If two shelves are used, food on the shelf in the higher position will cook first and should then be removed to allow the food on the lower shelf to finish cooking.

Pizza

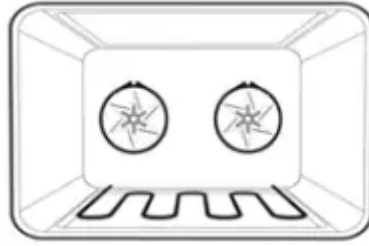

“Pizza” is a combination of “Base Heat” and “Fan Forced” and offers you the combined benefits of both functions. Heat comes from the elements surrounding the fans as well as the clean heat element below the oven floor.

The “Pizza” function is ideal for foods that require cooking and browning on the base. It is great for foods such as pizzas, quiches, meat pies and fruit pies. Simply place the food in the middle of the oven and set the desired temperature.

Defrost

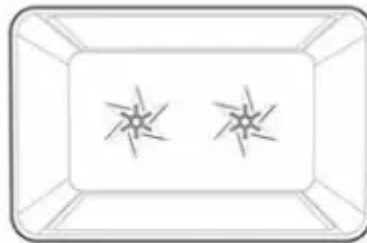

The “Defrost” function uses low temperature air that is circulated by the fans. You can defrost (thaw) your food before you cook it. You can also use “Defrost” to raise your yeast dough and to dry fruit, vegetables and herbs.

Fan & Grill

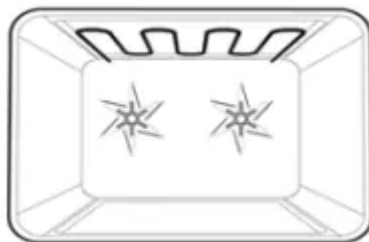

“Fan&Grill” offers you the benefits of both “Bake” and traditional “Grill” functions. The grill element turns on and off to maintain the set temperature while the fans circulate the heated air. The oven door remains closed for fan grill. You can use “Fan&Grill” for large cuts of meat to give you a result that is similar to “roisserie” cooked meat. Put your food on a shelf in the second lowest shelf position. Put the grill dish on the lowest shelf position to catch any spills. When using “Fan&Grill” it is not necessary to turn the food over during the cooking cycle. Set the temperature to 180°C.

Grill

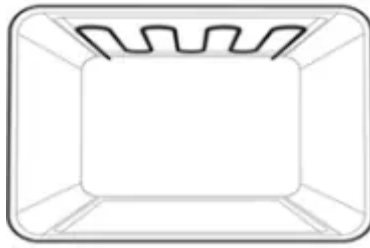

The “Grill” directs radiant heat from the powerful upper element onto the food. You can use the “Grill” function for tender cuts of meat, steak, chops, sausages, fish, cheese toasties and other quick cooking foods. Grill with the oven door closed. Preheat your grill for 3 minutes to get the best results. This will help seal in the natural juices of steak, chops etc. for a better flavour.

Left Grill (WVEP917DSC model only)

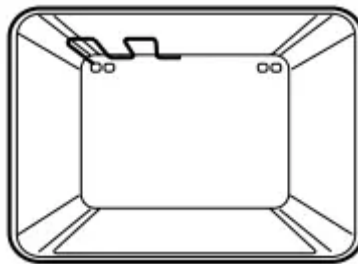

‘The ‘Left Grill’ directs radiant heat from only one of the powerful upper elements onto the food. The ‘Left Grill’ function is used instead of ‘Full Grill’ when only half the amount of grill area is needed. Left Grill has 2 temperature settings, ‘LO’ and ‘HI’. Grill with the oven door closed.’

Maxi Grill/Full Grill

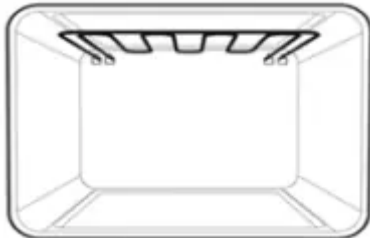

“Maxi Grill/Full Grill” directs radiant heat from 2 powerful upper elements onto the food. You can use the “Maxi Grill/Full Grill” function for tender cuts of meat, steak, chops, sausages, fish, cheese toasties and other quick cooking foods. Grill with the oven door closed. “Maxi Grill/Full Grill” allows you to take full advantage of the large grill dish area and will cook faster than normal “Grill”. For best results it is recommended to preheat your grill for 3 minutes. This will help seal in the natural juices of steak, chops etc. for a better flavour.

Pyro Clean



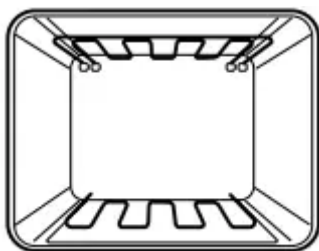

The oven has a Pyrolytic self-cleaning function. It cleans by burning off the spatters and accumulated dirt and grease from the oven liner, at high temperature. This process produces ash which can then be wiped out of the oven cavity.

Pyrolytic cleaning will not remove salt and mineral residue left in the cavity well when water evaporates. It is recommended that such residue is cleaned prior to conducting pyrolytic cleaning cycle.

Roast



The Roast Function is designed for roasting meats and poultry by utilising heat from all elements in combination with the fan to surround the food. This provides even cooking throughout and enhanced browning. This function starts at a higher temperature to seal the meat. The oven will then automatically reduce to the selected temperature to cook the meat for as long as desired. For example, if you use the default 200°C the “Roast” cycle will start at 220°C and then lower to 200°C.

Cooling/Venting fan

Your built-in appliance is fitted with a cooling fan. This prevents your kitchen cabinet from overheating and reduces the condensation inside the oven. It will operate whenever you are using your oven or grill and will blow warm air across the top of the oven door. In some appliances the cooling fan may continue to operate after the appliance is turned off. It will switch off by itself once oven is cool.

Condensation

Excess condensation may fog the oven door. This may happen when you are cooking large quantities of food from a cold start. You can minimise condensation by:

- Keeping the amount of water used whilst cooking to a minimum.
- Making sure that the oven door is firmly closed.

- Baking custard in a baking dish that is slightly smaller than the water container.
- Cooking casseroles with the lid on.

NOTE: If you are using water in cooking, this will turn to steam and may condense outside your appliance. This is not a problem or fault with your oven.

Preheating your oven with rapid heat

To preheat your oven select the “Rapid Heat” function.

This function allows your oven to reach the preset temperature quicker than any other cooking function.

1. Turn the function selector to “Rapid Heat”.
2. Set the desired preheat temperature, by rotating your oven temperature selector. When the indicator light above the temperature selector goes out, the oven has reached the desired temperature. Select the oven function you require for cooking or baking and place the food in the oven.

NOTE: WVE915SCA and WVEP917DSC have Fast Heat Up function. See ‘Operating WVE915SCA and WVEP917DSC’ chapter.

On completion of cooking

- The heat source will turn off, the timer will beep and the end time and/or cook time ‘indicators’ will flash.
- Even though the heating element turns off the oven will still retain substantial heat. This will continue to cook the food until it is removed or the oven cools down. If you do not plan on being present when the oven turns off, you should take this extra heating time into account.
- Turn the function and temperature controls to the off position.
- Press any button to stop the timer beeping.

Operating

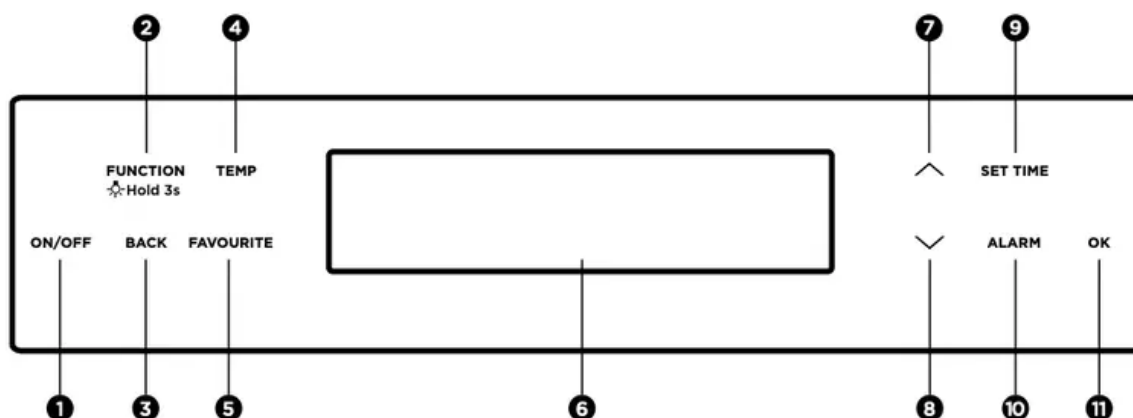

Use the sensor fields to operate the oven.

	FUNCTION	DESCRIPTION
1	ON/OFF	To turn the oven on and off
2	Heating functions or Assisted Cooking	Press the sensor field once to choose a heating function. To turn the light on or off, press the sensor field for 3 seconds
3	Back	To go back one level in the menu. To show the main menu, press the field for 3 seconds
4	Temperature selection/Fast Heat Up	To set the temperature or show the current temperature in the oven. Press the field for 3 seconds to turn the “Fast Heat Up” function on or off
5	Favourites	To save and access your favourite programs
6	Display	Shows the current settings of the oven
7	Up	To move up in the menu
8	Down	To move down in the menu
9	Time and additional functions	To set different functions. when a heating function operates, press the sensor field to set the timer or the “Function Lock” or “Favourites” functions
10	Minute minder	To set the “Minute Minder” function
11	OK	To confirm the selection or setting



Display

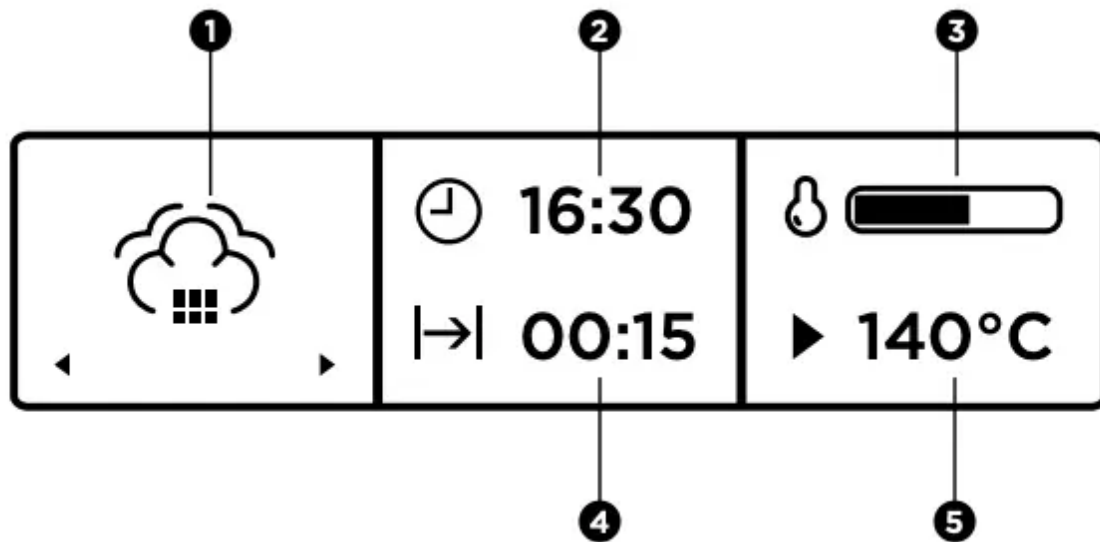

1 Heating function









2 Time of day

3 Heat-up indicator

4 Function duration/end time

5 Temperature



Other indicators of the display:

SYMBOL	FUNCTION	DESCRIPTION
	Minute minder	The function is currently working
	Time of day	The display shows the current time
	Duration	The display shows the necessary time for cooking
	End time	The display shows when the cooking time will be complete
	Temperature	The display shows the temperature
	Time indication	The display shows how long the heating function works. Press ^ and v at the same time to reset the time
	Heat-up indicator	The display shows the temperature in the oven
	Fast heat up	The function is on. It decreases the heat up time

Submenu for “Basic Settings”

SYMBOL	FUNCTION	DESCRIPTION
	Set time of day	Sets the current time on the clock.
	Time indication	When ON, the display shows the current time when you deactivate the appliance.
	Fast heat up	When on, fast heat up will be activated automatically in heating function. When off, the fast heat up can be activated by pressing TEMP for 3 seconds at the start of a heating function.
	Time extension	Activates and deactivates the time extension function.
	Display contrast	Adjusts the display contrast.
	Display brightness	Adjusts the display brightness.
	Buzzer volume	Adjusts the volume of press-tones and signals by degrees.
	Key tones	Activates and deactivates the tone of the touch fields. It is not possible to deactivate the tone of the ON/OFF touch field.
	Alarm/error tones	Activates and deactivates the alarm tones.
	Cleaning reminder	Reminds you when to clean the appliance (Pyrolytic models only).
	DEMO mode	Activation/deactivation code: 2468.
	Service	Shows the software version and configuration.
	Factory settings	Resets all settings to factory settings.
	Back	Back to previous menu

Navigating the menus

1. Turn on the oven
2. Press  or  to select the menu option
3. Press OK to move to the submenu or accept the setting



At each point you can go back to the main menu with BACK

Setting a heating function

1. Turn on the oven.
2. Select a heating function.
3. Press OK to confirm.
4. Set the temperature.
5. Press OK to confirm.

Heat-up indicator



When you turn on a heating function, the bar on the display comes on. The bar shows that the temperature increases. When temperature is reached the buzzer sounds 3 times and the bar flashes and then disappears.

Fast Heat Up

This function decreases the heat-up time.



Do not put food in the oven when the Fast heat up function is on.

To turn on the function, hold TEMP for 3 seconds. The heat-up indicator alternates.



The temperature bar moves horizontally to indicate that Fast Heat Up is on. This function is not available for some oven functions.

Automatic Fast Heat Up

Fast Heat Up can be set to be automatically activated.





1. Go to Settings
2. Go to Fast Heat Up
3. Select ON or OFF to activate or deactivate automatic Fast Heat Up

Residual heat

When you turn off the oven, the display shows the residual heat. You can use the heat to keep the food warm.

Clock functions

Clock functions table

Symbol	Clock function	Application
	Minute Minder	To set a countdown (max. 2 h 30 min). This function has no effect on the operation of the oven. Use SET TIME to turn on the function. Press  or  to set the minutes and OK to start.
	Duration	To set how long the oven works (max. 23 h 59 min).
	End Time	To set the switch-off time for a heating function (max. 23 h 59 min).

If you set the time for a clock function, the time starts to count down after 5 seconds.



If you use the clock functions: Duration, End Time, the oven turns off the heating elements after 90% of the set time. The oven uses the residual heat to continue the cooking process until the time ends (3 - 20 minutes).



Setting the clock functions



Before you use the functions: Duration, End Time, you must set a heating function and temperature first. The oven turns off automatically.

You can use the functions: Duration and End Time at the same time if you want to automatically turn on and turn off the oven on a given time later.

The functions: Duration and End Time do not work when you use the core temperature sensor.

1. Set a heating function.
2. Press SET TIME again and again until the display shows the necessary clock function and the related symbol.
3. Press  or  to set the necessary time.

4. Press to confirm.

When the time ends, a signal sounds. The oven turns off. The display shows a message.

5. Press any symbol to stop the signal.

Time Extension

The function: Time Extension makes the heating function continue after the end of Duration.

1. When the cooking time ends, a signal sounds. Press any symbol. The display shows the message.
2. Press SET TIME to turn on or BACK to cancel.
3. Set the length of the function.
4. Press OK .

Additional Functions



Favourites



You can save your favourite settings, such as duration, temperature or heating function. They are available in the menu: Favourites. You can save 20 programs.

Saving a favourite program

1. Turn on the oven.
2. Set a heating function or an automatic program.
3. Press FAVOURITE again and again until the display shows: SAVE.
4. Press OK to confirm.

The display shows the first free memory position.

5. Press OK to confirm.
6. Enter the name of the program. The first letter flashes.
7. Press  or  to change the letter.
8. Press OK . The next letter flashes.
9. Do step 7 again as necessary.
10. Press and hold OK to save.

You can overwrite a memory position. When the display shows the first free memory position, press  or  and press OK to overwrite an existing program.

You can change the name of a program in the menu: Edit Program Name.

Activating a favourite program

1. Turn on the oven.

2. Press FAVOURITE.
3. Select your favourite program name.
4. Press OK to confirm.

Using the Child Lock

When the Child Lock is on, the oven cannot be turned on accidentally.

If the Pyrolysis function works, the door locks automatically. A message comes on in the display when you press any symbol.

1. Press ON/OFF to turn on the display.
2. Press TEMP and FAVOURITE at the same time until the display shows a message. To turn off the Child Lock function, repeat step 2.

Function Lock

This function prevents an accidental change of the heating function. You can turn it on only when the oven works.

1. Turn on the oven.
2. Set a heating function or setting.
3. Press TEMP again and again until the display shows: Function Lock.
4. Press OK to confirm.



If the Pyrolysis function works, the door is locked and the symbol of a key comes on in the display.

To turn off the function, press TEMP . The display shows a message. Press TEMP again and then OK to confirm.



When you turn off the oven, the function also turns off

Hints and tips

Automatic Switch-Off

For safety reasons the oven turns off automatically after some time, if a heating function works and you do not change any settings.

Temperature (°C)	Switch-off time (h)
30 - 115	12.5
120 - 195	8.5
200 - 245	5.5
250 - maximum	3
Pyrolytic Cleaning	4.5



The Automatic Switch-off does not work with the functions: Light, Duration, End Time.

Brightness of the display

There are two modes of display brightness:

- Night brightness - when the oven is turned off, the brightness of the display is lower between 10pm and 6am.
- Day brightness:
 - when the oven is turned on.
 - if you touch a symbol during the night brightness (apart from ON/OFF), the display goes back to the day brightness mode for the next 10 seconds.
 - if the oven is turned off and you set the function: Minute Minder. When the function ends, the display goes back to the night brightness.

EASY BAKE STEAM

Your WVEP917DSC has the ability to add steam while baking. Cooking with steam is a great addition to straight 'hot air' cooking. Steam brings out all the natural flavours and goodness in the food, cooks evenly from surface to centre and retains more nutrients and vitamins. Steam assisted cooking consistently produces juicy, succulent interiors with crisp, golden exteriors.

WARNING

Risk of burns and damage to the appliance.

- Do not open the appliance door when the steam function operates, with the exception of preheating.
- Open the appliance door with care after the steam function stops.
- Refer to cleaning the appliance for cleaning after the steam function operates.

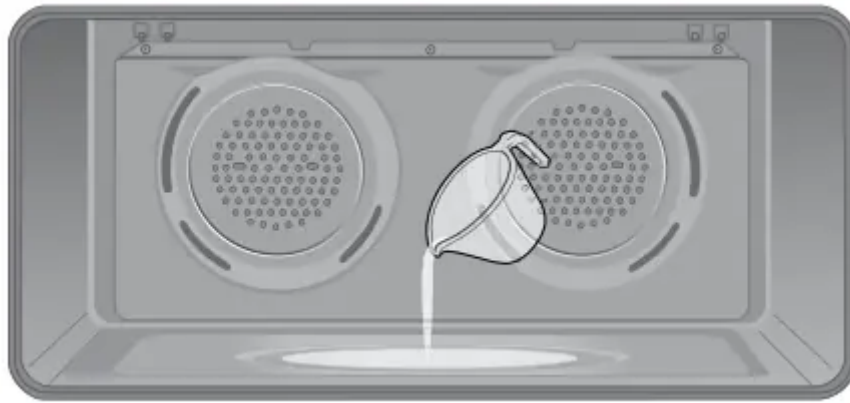

1. Open the oven door.
2. Fill the cavity well with 200ml of water (only when the oven is cold).
3. Set the 'Easy Bake Steam' function.
4. Set the temperature using the \wedge and \vee symbols.
5. Preheat the oven for 10 minutes or according to the recipe suggestions.
6. Place food in the appliance and close the oven door.

CAUTION Do not refill the cavity well with water during cooking or when the oven is hot to avoid damage to enamel.

WARNING Make sure that the appliance is cool before you remove the remaining water from the cavity well.

COOKING TEST

Get to know your new oven with this 'Simple Test Cake'

Although we strive for a perfect performing oven, it's possible that there will be some variation in colour when baking. Therefore, we suggest this simple, easy and delicious to make Simple Test Cake, it can help you understand your new oven. All ovens do sometimes have hot or cold spots, therefore it is important to judge with your eye as you may require to rotate during baking.

'Simple Test Cake'

- 125g butter, softened to room temperature
- 1 cup caster sugar
- 1 teaspoon pure vanilla essence
- 4 large eggs
- 2 cups self-raising flour pinch of salt
- 4 tablespoons (80ml) full-cream milk

Method:

1. Butter base and sides of two 20cm straight-sided round or square cake pans. Then line the base with grease proof or baking paper.
2. Preheat oven to moderate '180°C' (170°C fan forced) and ensure oven shelf is in the centre position of oven.
3. Cream softened butter and sugar until light in colour.
4. Add vanilla essence.
5. Then eggs one at a time, beating well after each addition.
6. Sift flour and salt into the mixture and beat until well combined.
7. Add milk and beat or stir to combine.
8. Spoon mixture equally between prepared cake pans.
9. Bake in preheated oven, middle shelf for about 25 to 35 minutes or until when tested with a fine cake skewer it comes out clean, or the edges of the cakes have come away slightly from the sides of the cake pans.
10. Remove from oven to wire cake rack and rest for 5 minutes before removing from cake pans. Cool completely.

To Serve: sandwich together with your favourite jam or conserve, and dust top with pure icing sugar.

NOTE: If desired substitute butter for either margarine or olive oil spread. Recipe is based on the Australian standard metric 250ml cup and 20ml tablespoon sets.

COOKING GUIDE

- For best baking results preheat oven for 30 minutes.
- Select the correct shelf location for food being cooked.
- The grill tray can be used in the oven as a baking dish.
- Make sure dishes will fit into the oven before you switch it on.
- Keep edges of trays at least 40mm from the side of the oven. This allows free circulation of heat and ensures even cooking.
- Do not open the oven door more than necessary.
- Do not place foods with a lot of liquid into the oven with other foods. This will cause food to steam and not brown.
- After the oven is turned off it retains the heat for some time. Use this heat to finish custards or to dry bread.

- Do not use a lot of cooking oil when roasting. This will prevent splattering oil on the sides of the oven and the oven door. Polyunsaturated fats can leave residue which is very difficult to remove.
- For sponges and cakes use aluminium, bright finished or non-stick utensils.
- Remove unnecessary trays or dishes when roasting or baking

Oven shelf location

Your oven has 5 positions for mounting the shelves or grill dish carrier. These are numbered from 1 (the lowest shelf position) to 5 (the highest shelf position). See diagram.

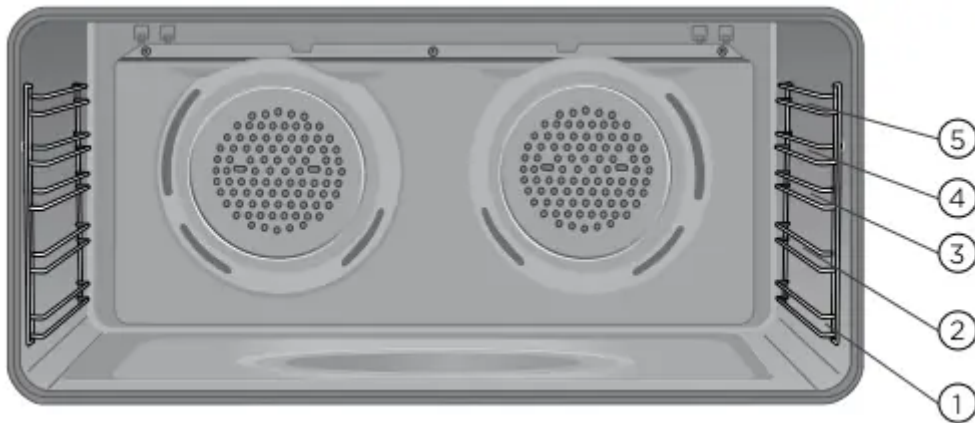

To give maximum space above and below the shelves, load them in this way:

- When cooking with 1 shelf, use position 2 or 3.
- When cooking with 2 shelves, use position 1 and 3.
- When grilling use position 4 or 5.

NOTE: Use the oven efficiently, by cooking many trays of food at the same time e.g. 2 trays of scones, small cakes or sausage rolls.

DEALING WITH COOKING PROBLEMS

PROBLEM	CAUSES	REMEDIES
Uneven cooking:	<ul style="list-style-type: none"> • Incorrect shelf position. • Trays not centralised. • Air flow in oven uneven. • Grill/Baking dish affecting thermostat. 	<ul style="list-style-type: none"> – Select shelf that puts food in the centre of the oven. – Centre trays. – Rotate food during cooking. – Remove Grill/Baking dish from oven on bake modes.
Baked products too brown on top:	<ul style="list-style-type: none"> • Oven not preheated. • Baking tins too large for the recipe. • Baking tins not evenly spaced. • Products not evenly sized or spaced on trays. • Baking temperature too high. 	<ul style="list-style-type: none"> – Preheat the oven. – Use correct size tins. – Stagger baking tins at least 3cm between tins and the oven walls. – Make into same size and shape, & spread evenly over trays. – Lower the temperature.
Baked products too brown on bottom:	<ul style="list-style-type: none"> • Baking tins too large for the recipe. • Baking tins are dark metal or glass. • Food too low in the oven. • Oven door opened too frequently during baking. • Baking temperature too high. • Grill/Baking dish affecting thermostat. 	<ul style="list-style-type: none"> – Use correct size tins. – Change to shiny, light tins or lower the temperature by 10°C. – Cook one shelf higher. – Don't open the oven door until at least half the cooking time has passed. – Lower the temperature. – Remove Grill/Baking dish from oven on bake modes.
Cakes have a cracked, thick crust:	<ul style="list-style-type: none"> • Baking temperature too high. • Food too high in oven. 	<ul style="list-style-type: none"> – Lower the temperature. – Cook one shelf lower. – Mix just long enough to combine ingredients.

	<ul style="list-style-type: none"> • Cake batter over mixed. • Pan too deep. • Baking pans dark 	<ul style="list-style-type: none"> – Check size of pan and use recommended size. – Change to shiny pans.
Baked products are pale, flat and undercooked:	<ul style="list-style-type: none"> • Baking temperature too low. • Food too low in oven. • Baking time too short. • Incorrect tin size 	<ul style="list-style-type: none"> – Raise the temperature. – Cook one shelf higher. – Increase cooking time. – Use correct size tin.
Cakes fallen in the centre:	<ul style="list-style-type: none"> • Baking temperature too low. • Baking time too short. • Proportions of ingredients incorrect in the recipe. • Opening door too early in baking. 	<ul style="list-style-type: none"> – Raise the temperature. – Increase cooking time. – Check recipe. – Do not open the door until the last quarter of cooking time.
Roast meat and potatoes not browning in fan oven:	<ul style="list-style-type: none"> • Poor hot air circulation. • Grill/Baking dish affecting thermostat. 	<ul style="list-style-type: none"> – Elevate food onto a rack to allow air circulation. – Remove Grill/Baking dish from oven on bake modes.
Juices running out of meat:		<ul style="list-style-type: none"> – Do not pierce meat with fork, turn with tongs.
Grilled meats overcooked on outside and raw in the centre:		<ul style="list-style-type: none"> – Grill at lower insert position.
Grilled chops and steaks curling:		<ul style="list-style-type: none"> – Cut into fat every 2cm (1").

CLEANING YOUR OVEN

WARNING

- Always switch off power to the oven before cleaning.
- Do not line the bottom of the oven with foil or cookware.
- Do not use steam cleaners.

Stainless steel

WARNING The oven door trim and the control panel are decorated with a special stainless steel that resists finger marks and should only be cleaned with warm water and a mild detergent. Do not use stainless steel cleaners, abrasive cleaners or harsh solvents on these parts.

NOTE: Make sure you follow the polish or brushing lines in the stainless steel.

- All grades of stainless steel can stain, discolour or become greasy. You must clean these regularly by following the procedures below if you want your appliance to look its best, perform well and have a long life.
- Care must be taken when wiping exposed stainless steel edges, they can be sharp!
- A suitable cleaner can be purchased from Electrolux Customer Care Centres.

Glass

- Glass surfaces on doors and control panels are best cleaned immediately after soiling.
- A damp cloth may help remove baked on food deposits.

WARNING

The door glass on this appliance is made from a tough, durable material that withstands heating and cooling without breaking. However, it must be remembered that it is GLASS, it may break. Treat it accordingly! Should you have any questions about the glass in your new appliance, please contact the customer care centre by dialling 1300 363 640.

Do not use harsh abrasive cleaners or sharp metal scrapers to clean the oven door since they can scratch the surface, which may result in the shattering of glass.

Oven

- Always keep your appliance clean. Ensure that fats and oils do not accumulate around elements or fans.
- Always keep the oven shelves, baking tray, grill dish and grill dish insert clean, as any fat deposits may catch fire.
- Always wrap your meats in foil or an oven roasting bag to minimise cleaning. Any polyunsaturated fats can leave a varnish-like residue which is very difficult to remove.

Removing the trays and shelves from your appliance

- Remove trays by simply pull them out taking care not to spill the contents.
- Slide shelves towards you until they reach the front stop.
- Tilt them up at the front to clear the side supports.
- Lift them clear.
- Wash the trays and shelves in hot soapy water.
- Reverse the above steps to put the trays and shelves back again.
- Ensure that they are placed between the support wires.

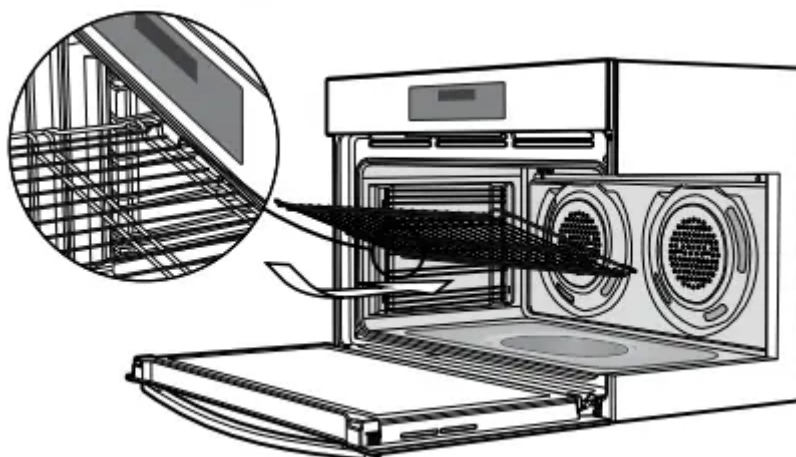

Removing the side racks or shelf supports

- Grasp the shelf support at the front.
- Pull it firmly inwards

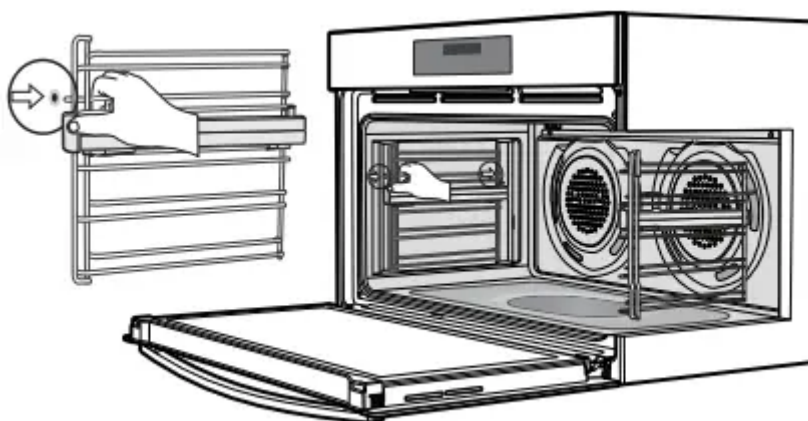

Cleaning your oven door

The oven door has been designed to allow the two inner door glasses to be removed for cleaning without removing the door from the product.

Removing the inner door glass for cleaning:

- Open the door fully to gain access to the hinges.
- Push down the hinge locking tab as shown in the diagram on both sides of door.

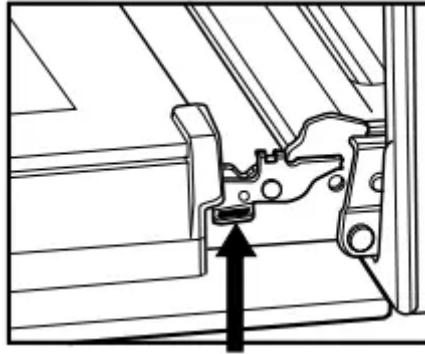

Locking tab up - normal position

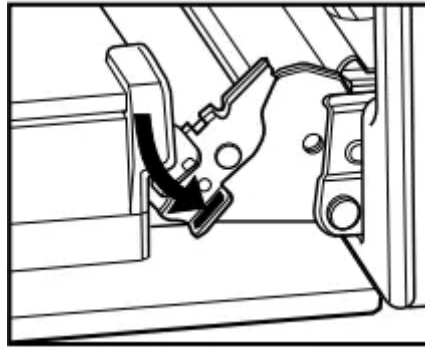

Locking tab down - for cleaning

- Gently close the door until it stops in partially open position on the locking tab (the door will not fully close with the locking tab in the down position).
- In this position the top door trim can be removed by pushing each side on the serrated surface to release the clips and lift the trim away from the door.
- To remove the inner glass, tilt top of glass towards the oven and lift out.
- The middle glass is removed in the same way.
- The inner side of outer glass can be cleaned in-situ when inner and middle glass is removed.
- Clean glass using detergent and warm water, wipe clean and dry thoroughly

Re-assembling the door glass panels :

- Replace the middle glass back to the door. The middle glass is a clear pane and orientation of the glass is not important.
- Replace the inner glass back to the door, ensuring the side with black ceramic paint faces away from the oven cavity when door is closed.
- Fully open the door and return the locking tabs to their normal position and close the door.

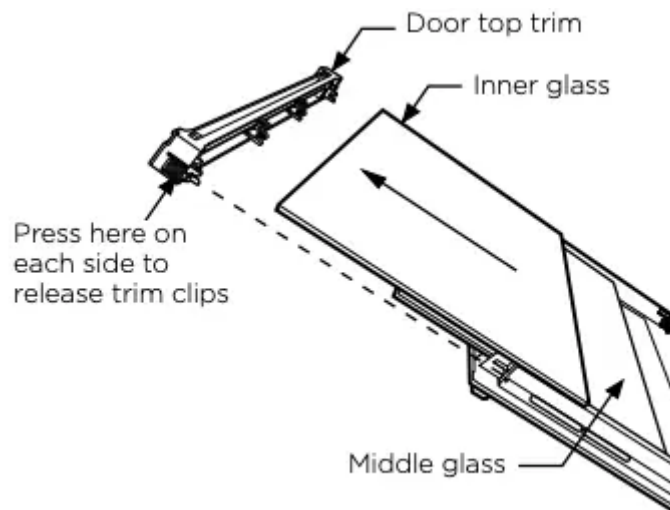

Cleaning your oven door

WARNING

- DO NOT use the oven without the inner and middle door glass fitted.
- NEVER spray any caustic cleaners on any surface of the door or damage to the surface coatings will result.
- DO NOT use metal utensils, scrapers, scourers, or abrasive cleaners to clean the glass or any of the door trims. These will damage or scratch the surface coatings and degrade the finish and appearance.
- DO NOT place glass in dishwasher.
- Use only warm water and liquid detergent with a soft cloth to clean the glass or trims.
- Before refitting the glass panes to the door ensure they are dried with a soft cloth.
- The glass edges have been specially ground to remove any sharp edges. However it is glass, and should be handled carefully to avoid injury to yourself and damage to the glass.

WARNING Make sure the appliance power is switched off at the isolating switch before you remove or replace parts, to avoid the possibility of electric shock.

Changing the light globes

- There are 2 light globes located in the top of the oven cavity towards the front. The light globe glass is accessible between the passes of the upper element.
- To remove, turn oven light glass anti-clockwise.
- A special high temperature resistant globe should be used. This can be purchased from the customer care centre

TROUBLESHOOTING

Faults

If there is a problem with the oven and/or grill, please:

- Check the points listed below before calling for service. It may be possible to avoid a call by fixing the problem yourself – and so continue cooking.

NOTE: We may charge for service even in the guarantee period if your problem is due to the causes listed below

PROBLEM	POSSIBLE CAUSE	WHAT TO DO
Oven or grill not working	Power not turned on Household fuse blown Controls incorrectly set Circuit breaker tripped Clock not set Demo Mode 'ON' for WVE915SCA, WVEP916, WVEP917) Child Lock 'ON' for WVE915SCA, WVEP916, WVEP917)	Switch on electricity Check fuses Reset controls Check circuit breaker Set time of day on timer Deactivate DEMO Mode. Refer to 'Using your oven' Deactivate Child Lock. Refer to 'Using your oven'
Oven not heating enough	Foil or trays on bottom of oven Oven not pre-heated	Remove foil or trays Pre-heat oven for 30 minutes
Light & fans on continuously	Timer not in manual mode	Set timer to manual mode
Oven not working	Timer not in manual mode Household fuse blown	Set timer to manual mode Check fuses
Oven light not working	Household fuse blown Circuit breaker tripped Lamp blown or loose in socket	Check fuses Check circuit breaker Replace or tighten lamp
Cooker smoking when first used	Protective oils being removed	Turn grill on high for 30 mins and then the oven on 220°C for 1 hour
Too much condensation building up when baking	Too much water used when cooking	Reduce amount of water Leave oven door open after cooking
Smells when first using oven	Protective oils being removed	This is normal

Timer flashing	Power failure or interruption	Reset time of day
Shelf or telescopic runner slides out when door is opened	Oven cavity is not level with the ground.	Perform a check using a level to verify cause (refer to installation section). If not level refer to installer
Oven seal is loose	The oven seal is only attached at each corner. It may seem like a loose fit but when the oven door is closed it will function correctly	No action necessary

NOTE: Only authorised personnel should carry out servicing. If the household fuse continues to blow, call the Customer Care Centre.

Warning

This content is compiled from multiple sources and is provided for reference purposes only. It may not be complete or fully applicable to all situations. If you are unable to resolve your issue, please contact the product manufacturer or an authorized service provider for official support.

