

Owner's Guide Microwave

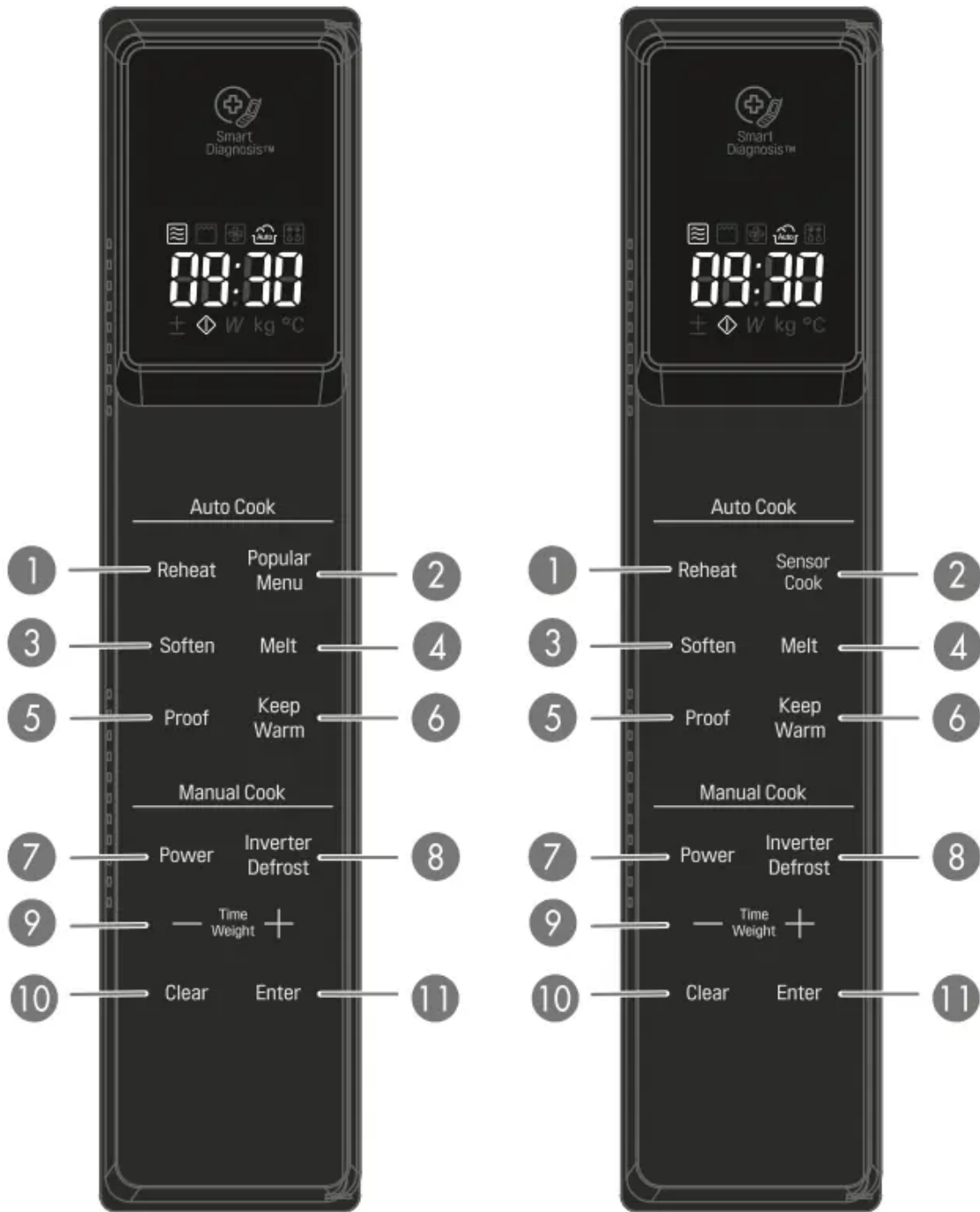

BEFORE USE

CONTROL PANEL



MS259 ****

MS429 ****

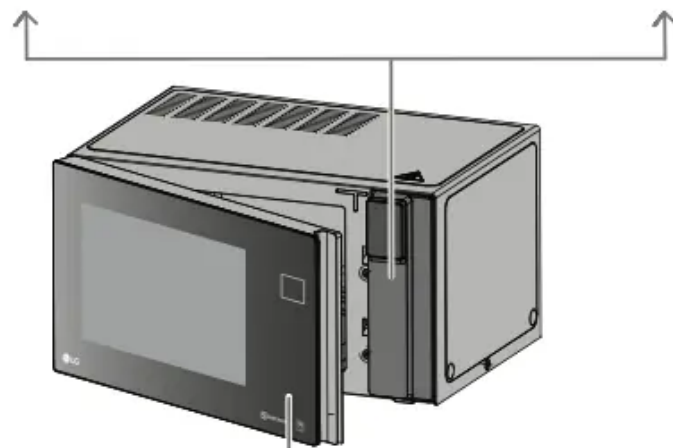

Part

1 REHEAT

See page 14 "Reheat"

2 POPULAR MENU / SENSOR COOK

See page 15 "Popular Menu" / "Sensor Cook"

3 SOFTEN

See page 18 "Soften "

4 MELT

See page 19 "Melt"

5 PROOF

See page 20 "Proof"

6 KEEP WARM

See page 21 "Keep warm"

7 POWER

See page 13 "Timed Cooking"

8 INVERTER DEFROST

See page 22 "Inverter Defrost"

9 MORE / LESS

See page 12 "More / Less"

- Choose the cooking menu.
- Set cooking time and weight.
- While cooking with auto and manual function, you can increase or decrease the cooking time at any point by pressing the - or + keys, or sliding the slide touch key. See page 11 "Slide Touch Key" (except defrost mode).





10 STOP / CLEAR

- Clears all functions and set entries except time of day.

11 START / ENTER

- Press this button to start cooking or resume cooking if the

DISPLAY ICON MEANINGS

Icon	
	Shows when the Microwave function is in operation.
	Shows when the Auto Cook function is in operation.
	Shows when the Inverter Defrost function is in operation.
	Shows in the display when More/Less time can be set.
	Shows when Cooking can be started by pressing the START button.
P-10~HI	Shows when the Cooking power level should be set.
kg	Shows when the food weight should be set.

SLIDE TOUCH KEY

By using the slide touch, you can adjust the cooking time or Defrost weight.

Example: Increase the cooking time, Touch and slowly slide from left to right.

1. Touch the (-) symbol of slide touch key with your finger.

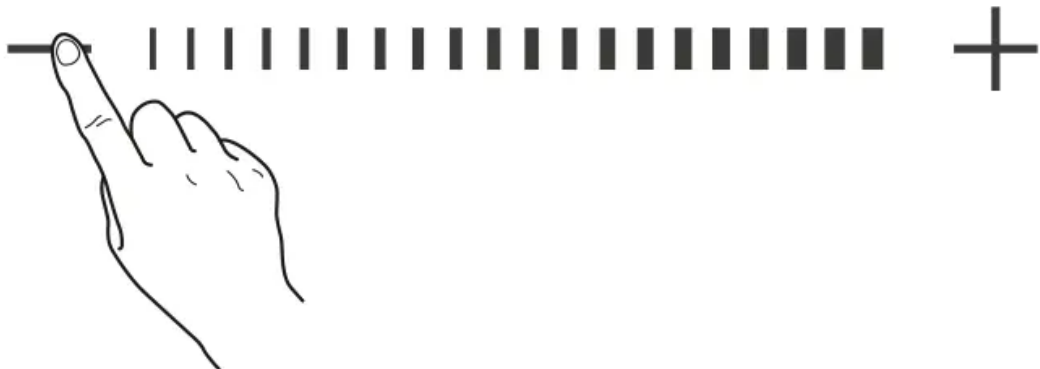

2. To increase the time, slowly slide your finger to the right.



Example: To Reduce cooking time, Touch and slowly slide from right to left.

1. Touch the (+) symbol of slide touch key with your finger.



2. To reduce the time, slowly slide your finger to the left.

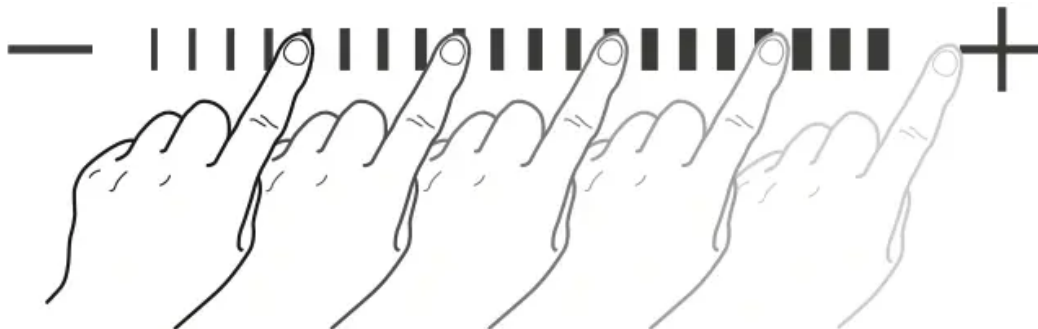

NOTE

1. Time setting

0~3 minutes : Time setting will increase or decrease by 10 second increments.

3~20 minutes : Time setting will increase or decrease by 30 second increments.

20~90minutes : Time setting will increase or decrease by 1 minute increments.

Operating microwave : Remaining time will increase or decrease by 10 second increments.

2. Defrost weight is set the same way as the cooking time. It will increase or decrease by 0.1kg.

THE RIGHT TOUCH

1. (-), (+) keys at both ends of Slide Touch Key can be used like the normal touch keys. By repeatedly touching the key once like the picture, you can set up the Cooking time or Defrost weight.



Touch

Touch

2. Place your finger in a centred position and sliding it along the centre of the slide scale.

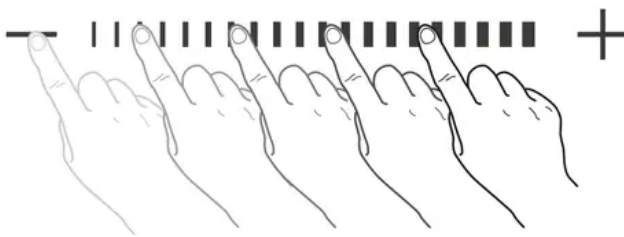

THE WRONG TOUCH

If you touch the key as follows, the slide touch key may not be recognised.

1. Touching the outside of the slide touch key.

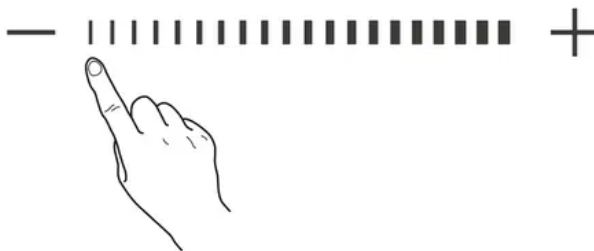

2. Touching the slide touch key using your finger nail or thumb.
3. Sliding the slide touch key too fast.

NOTE

- Don't use rubber gloves or disposable gloves when using the touch key or any other device or tool other than a finger.
- When wiping the touch control panel with a wet towel, dry off any remaining moisture from the touch control panel.
- If a (+), (-) button on the touch control panel is being pressed, and the setting no longer increases or decreases, then remove your finger and try again.

SETTING CLOCK

When your oven is plugged in for the first time or when power resumes after a power interruption, the numbers in the display reset to ' 12H '.

Example: To set 11:11

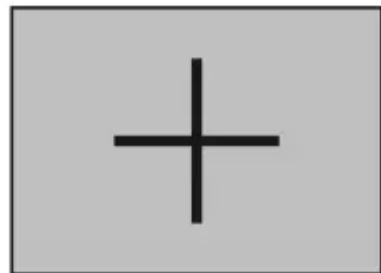
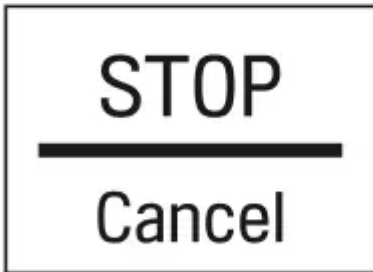
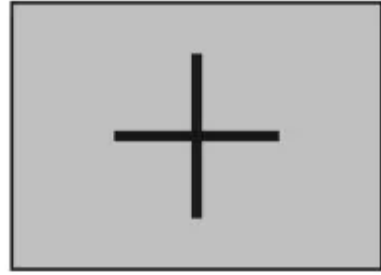

1. Close the Door.
Press + once.
'24H' will show in the display. (press + twice for 12 Hour mode)
2. Press START.
3. Press + eleven times until display shows '11:'
4. Press START.
5. Press + eleven times until display shows '11:11'
6. Press START.

You can also set the time by using the slide Touch Key after closing the door.

At the beginning of the power be provided, when you press the STOP button, you couldn't use the clock mode.

QUICK START

The QUICK START feature allows you to set 30 seconds intervals of HIGH power cooking with each touch of the START button.

Example: Set 2 minutes of cooking on high power

1. Close the Door.
Press STOP.



2. Select 2 minutes on high power.

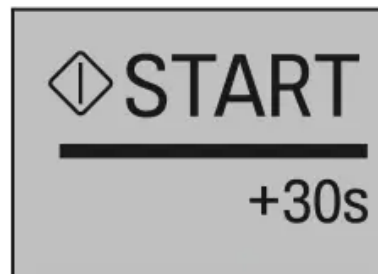

Press the START button four times

The oven will start before you have finished the fourth press.

During QUICK START cooking, you can extend the cooking time up to 99 minutes 59 seconds by repeatedly pressing the START button.

MORE/LESS

By using the (-) or (+) key, manual cook settings can be adjusted to cook food for a longer or shorter time. Pressing (+) will increase 10 seconds to the cooking time each time you press it. Pressing (-) will decrease 10 seconds of cooking time each time you press it. The max cooking time possible in the manual cook mode will be 99 min 59 seconds.

Example: To adjust the Reheat (ex. Dinner Plate 1 Serve) cooking time for a longer time, or for a shorter time

Clear

Enter



Reheat

Popular
Menu



STOP

Cancel

 **START**

+30s



1. Open the Door.
Press Clear.
2. Press Reheat three times.
'3' will show in the display.
3. Close the Door.
Press START.
4. Slide (+) or (-) Remaining time will increase or decrease by 10 seconds.

ENERGY SAVING

Energy saving means to save energy by turning off the display. This feature only operates when the Microwave Oven is in standby and the display will go out.

NOTE: When using clock mode, the display will remain on.

HOW TO USE

MANUAL COOKING (timed cooking)

This function allows you to cook food for a desired time. There are 10 power levels available. The example below shows how to set 90% power level for the desired time.

Example: To cook food on 90% Power for 5 minutes 30 seconds

Clear

Enter



Power

Inverter
Defrost



1. Open the Door. Press Clear.
2. Press Power twice, Display shows 'P-90 '. (1st time P-HI appears in the display. This is to tell you that the oven is set on 100% power unless a different power setting is chosen.)
3. Enter 5 minutes 30 seconds by pressing + until display shows '5 : 30'.
4. Close the Door.
Press START.

When cooking is complete, a chime will sound. The word End shows in the display window. 'End' remains in the display and the chime will sound every minute until the door is opened, or any button is pressed.

NOTE: If you do not select the power level, the oven will operate at power HIGH. To set HI-POWER cooking, skip step 2 above.

MICROWAVE POWER LEVELS

Your microwave oven is equipped with 10 power levels to give you maximum flexibility and control over cooking. The adjacent table will give you some idea of which foods are prepared at each of the various power levels.

- The adjacent chart shows the power level settings for your oven.

MICROWAVE POWER LEVEL CHART

Power Level		Use
MS259****	MS429****	
P-HI (100%) 1000 W	P-HI (100%) 1200 W	<ul style="list-style-type: none"> * Boiling water. * Browning ground beef. * Making candy. * Cooking poultry pieces, fish, & vegetables. * Cooking tender cuts of meat.
P-90 900 W	P-90 1080 W	<ul style="list-style-type: none"> * Reheating rice, pasta, & vegetables.
P-80 800 W	P-80 960 W	<ul style="list-style-type: none"> * Reheating prepared foods quickly. * Reheating sandwiches.
P-70 700 W	P-70 840 W	<ul style="list-style-type: none"> * Cooking egg, milk and cheese dishes. * Cooking cakes and breads. * Melting chocolate.
P-60 600 W	P-60 720 W	<ul style="list-style-type: none"> * Cooking veal. * Cooking whole fish. * Cooking puddings and custard.
P-50 500 W	P-50 600 W	<ul style="list-style-type: none"> * Cooking ham, whole poultry and lamb. * Cooking rib roast and sirloin tip.
P-40 400 W	P-40 480 W	<ul style="list-style-type: none"> * Thawing meat, poultry and seafood.
P-30 300 W	P-30 360 W	<ul style="list-style-type: none"> * Cooking less tender cuts of meat. * Cooking pork chops and roast.
P-20 200 W	P-20 240 W	<ul style="list-style-type: none"> * Taking chill out of fruit. * Softening butter.
P-10 100 W	P-10 120 W	<ul style="list-style-type: none"> * Keeping casseroles and main dishes warm. * Softening butter and cream cheese.

CHILD LOCK

This is a unique safety feature that prevents unwanted oven operations. Once the CHILD LOCK is set, no cooking can take place.

Example: To To set set the the CHILD LOCK

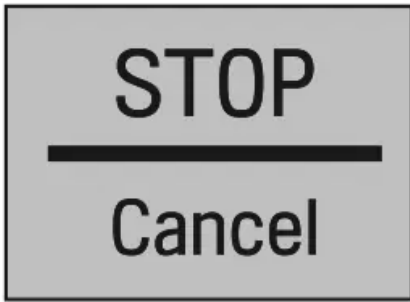

1. Close the Door. Press STOP.
2. Press and hold STOP until 'Loc' appears in the display and a chime is heard.

If the time of day was already set, the time of day will appear on the display window after 1 seconds.

If the CHILD LOCK was already set and you touch another key pad, the word Loc shows in the display. You can cancel the CHILD LOCK according to below procedure.

Example: To cancel the CHILD LOCK

Press and hold STOP until 'Loc' disappears in the display.

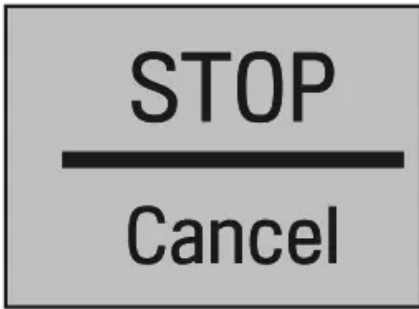

After the CHILD LOCK is turned off, the oven will operate normally.

REHEAT

Your oven's menu has been preprogrammed to automatically reheat food. Select one of the Reheat menus and then select the weight of the food. The microwave will then reheat the contents appropriately after the START button is pressed as in step 4 below.

Example: To reheat 0.2 kg Rice, simply follow the step below

Clear

Enter



Reheat

Popular
Menu

MS259****

or

Reheat

Sensor
Cook

MS429****

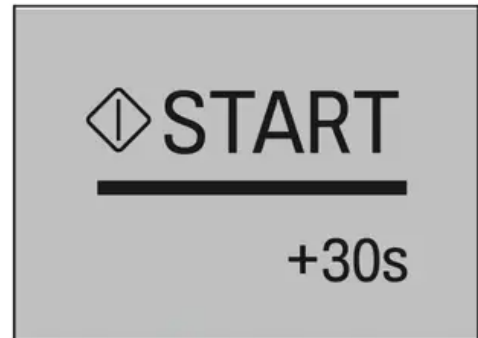
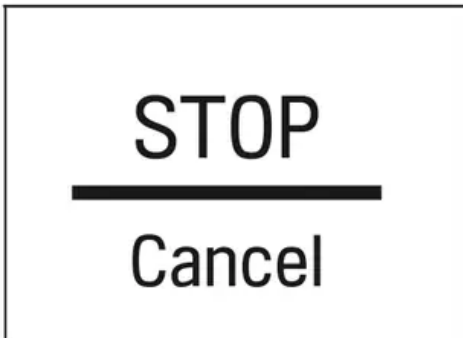
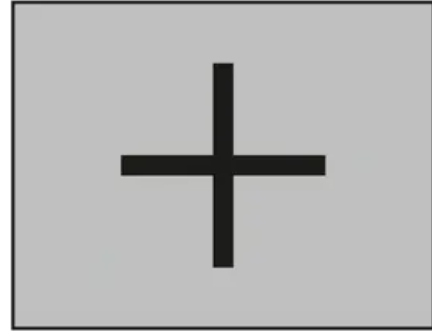
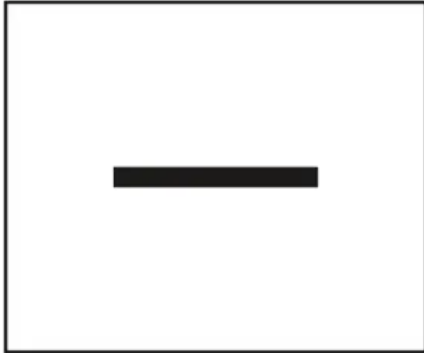

1. Open the Door.
Press Clear.
2. Press Reheat seven times.
'7' will show in the display.
3. Press + until display shows '0.2 kg'.

4. Close the Door.
Press START.

REHEAT MENU INSTRUCTIONS

Code	Menu	Weight Limit	Initial Temperature	Instructions	Utensil
1	Beverage	1 - 2 cups (1 cup / 200 ml)	Room	1. Place food on a microwave-safe cup. 2. Place food in the oven. Choose the menu and weight, press START.	Microwave-safe cup
2	Casserole	0.25 - 1.0 kg (250 g / 1 serving)	Refrigerated	1. Place food on a microwave-safe bowl. Cover with plastic wrap and vent. 2. Place food in the oven. Choose the menu and weight, press START. 3. After cooking, stand covered for 3 minutes.	Microwave-safe bowl
3	Dinner Plate	1	Refrigerated	1. Place food (0.4 - 0.5 kg of meat, chicken, mashed potato, vegetable etc.) on a microwave-safe dish. Cover with plastic wrap and vent. 2. Place food in the oven. Choose the menu, press START. 3. After cooking, stand covered for 3 minutes.	Microwave-safe dish
4	Muffin	1 - 4 (75 - 80 g / 1 muffin)	Frozen	1. Place food on a microwave-safe dish. 2. Place food in the oven. Choose the menu and weight, press START.	Microwave-safe dish

Code	Menu	Weight Limit	Initial Temperature	Instructions	Utensil
5	Pie	0.2 - 0.6 kg (150 - 200 g / piece)	Refrigerated	1. Cut leftover pie into pieces. 2. Place food on a microwave-safe dish. 3. Place food in the oven. Choose the menu and weight, press START.	Microwave-safe dish
6	Pizza	0.2 - 0.5 kg	Refrigerated	1. Place food on a microwave-safe dish. 2. Place food in the oven. Choose the menu and weight, press START.	Microwave-safe dish
7	Rice	0.1 - 0.3 kg	Refrigerated	1. Place food on a microwave-safe bowl. Cover with plastic wrap and vent. 2. Place food in the oven. Choose the menu and weight, press START. 3. After cooking, stand covered for 3 minutes.	Microwave-safe bowl
8	Soup	0.25 - 1.0 kg (250 g / 1 serving)	Room	1. Place food on a microwave-safe bowl. Cover with plastic wrap and vent. 2. Place food in the oven. Choose the menu and weight, press START. 3. After cooking, stand covered for 3 minutes.	Microwave-safe bowl

POPULAR MENU / SENSOR COOK

Your oven's menu has been preprogrammed to automatically cook food. Select a Popular Menu and weight, or, select one of the Sensor Cook menus and then press START to allow the microwave to cook your selection. Then let your microwave oven cook your selections.

Example: To cook 0.4 kg Fresh Vegetable, simply follow the step below

MS259****

Clear

Enter



Reheat

Popular Menu



—

+



STOP
Cancel

START
+30s



1. Open the Door.
Press Clear.
2. Press Popular Menu three times. '3' will show in the display.
3. Press + until display shows '0.4 kg'.
4. Close the Door.
Press START.

MS429****



Clear

Enter



Reheat

Sensor
Cook



STOP
Cancel

START
+30s

1. Open the Door.
Press Clear.
2. Press Sensor Cook three times. '3' will show in the display.
3. Close the Door.
Press START.

POPULAR MENU / SENSOR COOK INSTRUCTIONS

Code	Menu	Weight Limit	Initial Temperature	Instructions	Utensil																																																																											
1	Bacon	4 thin rashers	Refrigerated	<ol style="list-style-type: none"> Place food on paper towels on a microwave-safe dish. Cover with paper towels. Place food in the oven, choose the menu, press START. 	Microwave-safe dish																																																																											
2	Casserole	1 - 4	Room	<p>Tuna & Noodle</p> <table border="1"> <thead> <tr> <th>Serving</th> <th>1</th> <th>2</th> <th>3</th> <th>4</th> </tr> </thead> <tbody> <tr> <td>Noodles(Pasta), boiled</td> <td>140 g</td> <td>280 g</td> <td>420 g</td> <td>560 g</td> </tr> <tr> <td>Cream of mushroom soup</td> <td>140 g</td> <td>280 g</td> <td>420 g</td> <td>560 g</td> </tr> <tr> <td>Can or equivalent, Starkist chunk light tuna, in spring water, drained</td> <td>60 g</td> <td>120 g</td> <td>180 g</td> <td>240 g</td> </tr> <tr> <td>Milk</td> <td>125 ml</td> <td>250 ml</td> <td>375 ml</td> <td>500 ml</td> </tr> </tbody> </table> <ol style="list-style-type: none"> Combine cream of mushroom soup, tuna and milk on a microwave- safe bowl. Add boiled noodles and stir thoroughly. Cover with plastic wrap and vent. Place food in the oven. Choose the menu and weight, press START. After cooking, stand covered for 3 minutes. <p>Beef Stroganoff</p> <table border="1"> <thead> <tr> <th>Serving</th> <th>1</th> <th>2</th> <th>3</th> <th>4</th> </tr> </thead> <tbody> <tr> <td>Rump steak, cubed</td> <td>250 g</td> <td>500 g</td> <td>750 g</td> <td>1000 g</td> </tr> <tr> <td>Plain flour</td> <td>2 Tbsp</td> <td>1/4 cup</td> <td>1/2 cup</td> <td>1/2 cup</td> </tr> <tr> <td>Small onion, finely chopped</td> <td>1/2</td> <td>1</td> <td>1</td> <td>1</td> </tr> <tr> <td>Tomato puree</td> <td>2 tsp</td> <td>1 Tbsp</td> <td>1 1/2 Tbsp</td> <td>2 Tbsp</td> </tr> <tr> <td>Beef stock</td> <td>125 ml</td> <td>200 ml</td> <td>250 ml</td> <td>375 ml</td> </tr> <tr> <td>Red wine</td> <td>60 ml</td> <td>60 ml</td> <td>60 ml</td> <td>60 ml</td> </tr> <tr> <td>Mushroom, sliced</td> <td>25 g</td> <td>50 g</td> <td>75 g</td> <td>100 g</td> </tr> <tr> <td>Sour cream</td> <td>75 ml</td> <td>150 ml</td> <td>200 ml</td> <td>300 ml</td> </tr> <tr> <td>Salt and pepper to taste</td> <td></td> <td></td> <td></td> <td></td> </tr> </tbody> </table> <ol style="list-style-type: none"> Place steak, left flour and all other ingredients in a microwave-safe bowl. Cover with plastic wrap and vent. Place food in the oven. Choose the menu and weight, press START. After cooking, stand covered for 3 minutes. 	Serving	1	2	3	4	Noodles(Pasta), boiled	140 g	280 g	420 g	560 g	Cream of mushroom soup	140 g	280 g	420 g	560 g	Can or equivalent, Starkist chunk light tuna, in spring water, drained	60 g	120 g	180 g	240 g	Milk	125 ml	250 ml	375 ml	500 ml	Serving	1	2	3	4	Rump steak, cubed	250 g	500 g	750 g	1000 g	Plain flour	2 Tbsp	1/4 cup	1/2 cup	1/2 cup	Small onion, finely chopped	1/2	1	1	1	Tomato puree	2 tsp	1 Tbsp	1 1/2 Tbsp	2 Tbsp	Beef stock	125 ml	200 ml	250 ml	375 ml	Red wine	60 ml	60 ml	60 ml	60 ml	Mushroom, sliced	25 g	50 g	75 g	100 g	Sour cream	75 ml	150 ml	200 ml	300 ml	Salt and pepper to taste					Microwave-safe bowl
Serving	1	2	3	4																																																																												
Noodles(Pasta), boiled	140 g	280 g	420 g	560 g																																																																												
Cream of mushroom soup	140 g	280 g	420 g	560 g																																																																												
Can or equivalent, Starkist chunk light tuna, in spring water, drained	60 g	120 g	180 g	240 g																																																																												
Milk	125 ml	250 ml	375 ml	500 ml																																																																												
Serving	1	2	3	4																																																																												
Rump steak, cubed	250 g	500 g	750 g	1000 g																																																																												
Plain flour	2 Tbsp	1/4 cup	1/2 cup	1/2 cup																																																																												
Small onion, finely chopped	1/2	1	1	1																																																																												
Tomato puree	2 tsp	1 Tbsp	1 1/2 Tbsp	2 Tbsp																																																																												
Beef stock	125 ml	200 ml	250 ml	375 ml																																																																												
Red wine	60 ml	60 ml	60 ml	60 ml																																																																												
Mushroom, sliced	25 g	50 g	75 g	100 g																																																																												
Sour cream	75 ml	150 ml	200 ml	300 ml																																																																												
Salt and pepper to taste																																																																																
3	Fresh Vegetables	0.2 - 0.8 kg	Room	<ol style="list-style-type: none"> Prepare vegetables(carrots, broccoli, cauliflower, zucchini, beans, peas). Cut vegetables into even size pieces. Wash the vegetables and place food in a microwave- safe bowl. Add amount of water according to the quantity (0.2 - 0.4 kg: 2 tablespoons, 0.5 - 0.8 kg: 4 tablespoons). Cover with plastic wrap and vent. Place food in the oven. Choose the menu and weight, press START. After cooking, stir and stand covered for 3 minutes. 	Microwave-safe bowl																																																																											
4	Frozen Meat Pie	0.2 - 0.8 kg (150 - 200 g / piece)	Frozen	<ol style="list-style-type: none"> Remove all packaging. Place food on a microwave-safe dish. Place food in the oven. Choose the menu, press START. 	Microwave-safe dish																																																																											

Code	Menu	Weight Limit	Initial Temperature	Instructions	Utensil																																
5	Frozen Vegetables	0.2 - 0.8 kg	Frozen	<ol style="list-style-type: none"> 1. Prepare frozen vegetables(carrots, broccoli, cauliflower, zucchini, beans, peas). 2. Place food in a microwave-safe bowl. 3. Add amount of water according to the quantity(0.2 - 0.4 kg: 2 tablespoons, 0.5 - 0.8 kg: 4 tablespoons). Cover with plastic wrap and vent. 4. Place food in the oven. Choose the menu and weight, press START. 5. After cooking, stir and stand covered for 3 minutes. 	Microwave-safe bowl																																
6	Jacket Potatoes	0.2 - 1.0 kg (180 - 220 g / each)	Room	<ol style="list-style-type: none"> 1. Wash potatoes and dry with a paper towel. 2. Pierce each potato 8 times with a fork. 3. Place food on a paper towel in the oven. Choose the menu and weight, press START. 4. After cooking, stand for 3 minutes. 	Paper towel																																
7	Rice/Pasta	0.1 - 0.3 kg	Room	<p>Ingredients for rice</p> <table border="1"> <tr> <td>Rice</td> <td>100 g</td> <td>200 g</td> <td>300 g</td> </tr> <tr> <td>Butter, melted</td> <td>30 g</td> <td>40 g</td> <td>50 g</td> </tr> <tr> <td>Onion, grated</td> <td>50 g</td> <td>75 g</td> <td>100 g</td> </tr> <tr> <td>Chicken stock or water</td> <td>250 ml</td> <td>500 ml</td> <td>750 ml</td> </tr> <tr> <td>Salt</td> <td colspan="3">To taste</td> </tr> </table> <ol style="list-style-type: none"> 1. Add rice, melted butter and onion in a deep and large microwave-safe bowl(3 L) and mix well. Pour boiling chicken stock or water and add salt. Cover with plastic wrap and vent. 2. Place food in the oven. Choose the menu and weight, press START. 3. After cooking, stir and stand covered for 5 - 10 minutes if needed. <p>Ingredients for pasta</p> <table border="1"> <tr> <td>Pasta</td> <td>100 g</td> <td>200 g</td> <td>300 g</td> </tr> <tr> <td>Water</td> <td>400 ml</td> <td>800 ml</td> <td>1000 ml</td> </tr> <tr> <td>Salt</td> <td colspan="3">To taste</td> </tr> </table> <ol style="list-style-type: none"> 1. Place pasta and boiling water with salt in a deep and large microwave-safe bowl(3 L). Cover with plastic wrap and vent. 2. Place food in the oven. Choose the menu and weight, press START. 3. After cooking, Rinse pasta with cold water. 	Rice	100 g	200 g	300 g	Butter, melted	30 g	40 g	50 g	Onion, grated	50 g	75 g	100 g	Chicken stock or water	250 ml	500 ml	750 ml	Salt	To taste			Pasta	100 g	200 g	300 g	Water	400 ml	800 ml	1000 ml	Salt	To taste			Microwave-safe bowl
Rice	100 g	200 g	300 g																																		
Butter, melted	30 g	40 g	50 g																																		
Onion, grated	50 g	75 g	100 g																																		
Chicken stock or water	250 ml	500 ml	750 ml																																		
Salt	To taste																																				
Pasta	100 g	200 g	300 g																																		
Water	400 ml	800 ml	1000 ml																																		
Salt	To taste																																				
8	Risotto	1.2 kg	Room	<table border="1"> <tr> <td> Ingredients 200 g risotto rice 1 1/2 cups water or stock 1/2 cup milk 200 g beef, chopped 2 eggs 1 onion, chopped 50 g green peas 100 g grated cheese Salt and pepper to taste </td> </tr> </table> <ol style="list-style-type: none"> 1. Add all ingredients in a deep and large microwave-safe bowl and mix well. Cover with plastic wrap and vent. 2. Place the bowl in the oven. Choose the menu, press START. 3. After cooking, stir and stand covered for 5 - 10 minutes if needed. 	Ingredients 200 g risotto rice 1 1/2 cups water or stock 1/2 cup milk 200 g beef, chopped 2 eggs 1 onion, chopped 50 g green peas 100 g grated cheese Salt and pepper to taste	Microwave-safe bowl																															
Ingredients 200 g risotto rice 1 1/2 cups water or stock 1/2 cup milk 200 g beef, chopped 2 eggs 1 onion, chopped 50 g green peas 100 g grated cheese Salt and pepper to taste																																					

SOFTEN

The oven uses low power to soften foods (butter, cream cheese and ice cream) See the following table.

Example: To Soften 0.2 kg Cream Cheese.

Clear

Enter



Soften

Melt



—

+

1. Open the Door.
Press Clear.
2. Press Soften twice. '2' will show in the display.
3. Press + until display shows '0.2 kg'.
4. Close the Door.
Press START.

SOFTEN MENU INSTRUCTIONS

Code	Menu	Weight Limit	Initial Temperature	Instructions	Utensil
1	Butter	1 - 3 (100 - 150 g / each)	Refrigerated	<ol style="list-style-type: none"> 1. Unwrap and place on a microwave-safe dish. 2. Place food in the oven. Choose the menu and weight, press START. 3. Butter will be at room temperature and ready for use in a recipe. 	Microwave-safe dish
2	Cream Cheese	0.1 ~ 0.3 kg	Refrigerated	<ol style="list-style-type: none"> 1. Unwrap and place on a microwave-safe dish. 2. Place food in the oven. Choose the menu and weight, press START. 3. Cream cheese will be at room temperature and ready for use in a recipe. 	Microwave-safe dish
3	Ice Cream	2 or 4 cups	Frozen	<ol style="list-style-type: none"> 1. Remove lid and cover. 2. Place food in the oven. Choose the menu and weight, press START. 3. Ice cream will be soft enough to make scooping easier. 	

MELT

The oven uses low power to melt foods (butter, cheese and chocolate). See the following table.

Example: To Melt 0.2 kg Chocolate

Clear

Enter



Soften

Melt



—

+



1. Open the Door.
Press Clear.
2. Press Melt three times. '3' will show in the display.
3. Press + until display shows '0.2 kg'.
4. Close the Door.
Press START.

MELT MENU INSTRUCTIONS

Code	Menu	Weight Limit	Initial Temperature	Instructions	Utensil
1	Butter	1 - 3 (100 - 150 g / each)	Refrigerated	<ol style="list-style-type: none"> 1. Place on a microwave-safe bowl. 2. Place food in the oven. Choose the menu and weight, press START. 3. After cooking, stir to complete melting. 	Microwave-safe bowl
2	Cheese	0.2 ~ 0.4 kg	Refrigerated	<ol style="list-style-type: none"> 1. Use processed cheese food only. Unwrap and cut into cubes. 2. Place on a microwave-safe bowl. 3. Place food in the oven. Choose the menu and weight, press START. 4. After cooking, stir to complete melting. 	Microwave-safe bowl
3	Chocolate	0.1 ~ 0.3 kg	Room	<ol style="list-style-type: none"> 1. Chocolate chips or squares of baking chocolate may be used. 2. Unwrap and place on a microwave-safe bowl. 3. Place food in the oven. Choose the menu and weight, press START. 4. After cooking, stir to complete melting. 	Microwave-safe bowl

PROOF (fermenting)

This feature allows you to make Yogurt by pressing the Proof button.

To make 0.6 kg yogurt

Clear

Enter



Proof

Keep
Warm



STOP

Cancel

 **START**

+30s

- 1. Open the Door.
Press Clear.



2. Press Proof once.
'1' will show in the display.
3. Close the Door.
Press START.
'5h00' will show in the display.

PROOF MENU INSTRUCTIONS

Code	Menu	Weight Limit	Initial Temperature	Instructions	Utensil												
1	Yogurt	0.6 kg	Lukewarm	<p>Ingredients 500 ml pasteurized whole milk 100 g natural plain yogurt</p> <ol style="list-style-type: none"> 1. Thoroughly wash the proper sized microwave-safe bowl with hot water. 2. Pour 500 ml milk into the bowl. 3. Heat it about 2 minutes - 2 minutes 30 seconds on high microwave power until 40 - 50 °C temperature. 4. Add 100 ml yogurt into the bowl and stir well. 5. Cover with plastic wrap or lid and place food in the oven. Choose the menu, press START. 6. After proofing, stand in the refrigerator for about 5 hours. 7. Taste nice with jam, sugar or fruits. <p>Note :</p> <ul style="list-style-type: none"> • The following types of milk and yogurt may be used : <table border="1" style="width: 100%; border-collapse: collapse;"> <thead> <tr> <th colspan="2">Do use</th> <th colspan="2">Do not use</th> </tr> <tr> <th>Milk</th> <th>Yogurt</th> <th>Milk</th> <th>Yogurt</th> </tr> </thead> <tbody> <tr> <td>• Pasteurized whole milk</td> <td>• Natural plain yogurt</td> <td>• 2 %, 1 % or fat-free milk • High calcium milk • Soy milk • Leftover milk • Expired milk</td> <td>• Leftover yogurt • Expired yogurt</td> </tr> </tbody> </table> <ul style="list-style-type: none"> • Thoroughly wash all utensils with hot water and dry before proofing yogurt. • Make sure that the milk is lukewarm(40 - 50 °C) before proofing. • Don't shake or mix yogurt during proofing as this will affect the firmness of the yogurt. • If the amount of ingredients are greater than suggested, increase the proofing time. 	Do use		Do not use		Milk	Yogurt	Milk	Yogurt	• Pasteurized whole milk	• Natural plain yogurt	• 2 %, 1 % or fat-free milk • High calcium milk • Soy milk • Leftover milk • Expired milk	• Leftover yogurt • Expired yogurt	Microwave-safe bowl
Do use		Do not use															
Milk	Yogurt	Milk	Yogurt														
• Pasteurized whole milk	• Natural plain yogurt	• 2 %, 1 % or fat-free milk • High calcium milk • Soy milk • Leftover milk • Expired milk	• Leftover yogurt • Expired yogurt														

KEEP WARM

The Keep Warm function will keep hot food that has just been cooked at serving temperature. Use microwave-safe utensils.

Example: To keep food warm for 90minutes

Clear

Enter



Proof

Keep Warm



STOP

Cancel

 **START**

+30s

1. Open the Door.
Press Clear.



2. Press Keep Warm once. '1' will show in the display.
3. Close the Door.
Press START.
'1h30' will show in the display.

Notes :

Crisp foods (pastry, pies, turnovers, etc) should be uncovered during keep warm. Moist foods should be covered with plastic wrap or microwave-safe lid.

The amount of keep warm food is suitable for 1-3 servings. It should also be noted that moist food will become dryer the longer it is Kept Warm.

INVERTER DEFROST

Four defrost sequences are preset in the oven. The INVERTER DEFROST feature provides you with the best defrosting method for frozen foods. The cooking guide will show you which defrost sequence is recommended for the food you are defrosting.

For added convenience, the INVERTER DEFROST includes a built-in beep alert that reminds you to check, turn over, separate, or rearrange to get the best defrost results. Four different defrosting levels are provided.

(MEAT /POULTRY / FISH / BREAD)

Example: To defrost 1.2 kg of meat

Clear

Enter



Power

Inverter
Defrost



—

+



1. Open the Door.
Press Clear and place 1.2kg of frozen meat inside the oven.
2. Press Inverter Defrost once.
'dEF1' will show in the display.
3. Press + until display shows '1.2 kg'.
4. Close the Door.
Press START.

Note:

When you press the START button, the display changes to the defrost time count down. The oven will beep once during the DEFROST cycle.

At the beep, open the door and remove any portions that have thawed and turn.

Return frozen portions to the oven and press START to resume the defrost cycle.

- Remove fish, shellfish, meat, and poultry from its original wrapping paper or plastic package. Otherwise, the wrap will hold steam and juice close to the foods, which can cause the outer surface of the foods to cook.
- Place foods in a shallow container or in a microwave roasting dish to catch the drippings.
- Food should still be somewhat icy in the center when removed from the oven.
- The length of defrosting time varies according to how solidly the food is frozen.
- The shape of the package affects how quickly food will defrost. Shallow packages will defrost more quickly than a deep block.
- Depending on the shape of the food can be defrosted more or less.

INVERTER DEFROST MENU INSTRUCTIONS



Category	Food to be Defrosted
<p>MEAT (dEF1) 0.1-4.0 kg</p>	<p>Beef Ground beef, Round steak, Cubes for stew, Tenderloin steak, Pot roast, Rib roast, Rump roast, Chuck roast, Hamburger patty</p> <p>Lamb Chops, Rolled roast</p> <p>Pork Chops, Hot dogs, Spareribs, Country-style ribs. Rolled roast, Sausage</p> <p>Veal Cutlets (0.5 kg, 20 mm thick)</p> <p>Turn food over at beep. After defrosting, let stand for 5 - 15 minutes.</p>
<p>POULTRY (dEF2) 0.1-4.0 kg</p>	<p>Poultry Whole, Cut-up, Breast (boneless)</p> <p>Cornish Hens Whole</p> <p>Turkey Breast</p> <p>Turn food over at beep. After defrosting, let stand for 30 - 60 minutes.</p>
<p>FISH (dEF3) 0.1-4.0 kg</p>	<p>Fish Fillets, Whole Steaks</p> <p>Shellfish Crab meat, Lobster tails, Shrimp, Scallops</p> <p>Turn food over at beep. After defrosting, let stand for 5 - 10 minutes.</p>



TO CLEAN YOUR OVEN

1. Keep the inside of the oven clean

Food spatters or spilled liquids stick to oven walls and between the seal and door surfaces. It is best to wipe up spillovers with a damp cloth right away. Crumbs and spillovers will absorb microwave energy and lengthen cooking times and may even damage the oven. Use a damp cloth to wipe out crumbs that fall between the door and the frame. It is important to keep this area clean to assure a tight seal. Remove greasy spatters with a soapy cloth then rinse and dry. Do not use harsh detergent or abrasive cleaners. The metal tray can be washed by hand or in the dishwasher.

2. Keep the outside of the oven clean

Disconnect the mains plug from the power outlet before cleaning the oven to eliminate the possibility of electric shock. Clean the outside of your oven with soap and water then with clean water and dry with a soft cloth or paper towel. To prevent damage to the operating parts inside the oven, the water should not be allowed to seep into the ventilation openings. To clean control panel, open the door to prevent the oven from accidentally starting, and wipe a damp cloth followed immediately by a dry cloth. Press STOP after cleaning.

3. If steam accumulates inside or around the outside of the oven door, wipe the panels with a soft cloth. Steam or condensation build up inside the door is normal if foods are heated for a long period on higher power levels. This is not a malfunction. the condensation will eventually evaporate. Try covering the food or vary the heating levels and time to reduce any condensation forming in the door, this may also occur when the oven is operated under high humidity conditions and in no way indicates a malfunction of the unit.

4. The door and door seals should be kept clean. Use only warm, soapy water, rinse then dry thoroughly. **DO NOT USE ABRASIVE MATERIALS, SUCH AS CLEANING POWDERS OR STEEL AND PLASTIC PADS.**

Metal parts will be easier to maintain if wiped frequently with a damp cloth.

QUESTION & ANSWERS

FAQ	Answer
What's wrong when the oven light will not glow?	There may be several reasons why the oven light will not glow. Either the light bulb has blown or the electric circuit has failed.
Does microwave energy pass through the viewing screen in the door?	No. The holes, or ports, are made to allow light to pass; they do not let microwave energy through.
Why does the BEEP tone sound when a button on the control panel is touched?	The BEEP tone sounds to assure that the setting is being properly entered.
Will the microwave function be damaged if it operates empty?	Yes. Never run it empty.
Why do eggs sometimes pop?	When baking, frying, or poaching eggs, the yolk may pop due to steam build up inside the yolk membrane. To prevent this, simply pierce the yolk before cooking. Never microwave eggs in the shell.
Why is standing time recommended after microwave cooking is over?	After microwave cooking is finished, food keeps on cooking during standing time. This standing time finishes cooking evenly throughout the food. The amount of standing time depends on the density of the food.
Why doesn't my oven always cook as fast as the cooking guide says?	Check your cooking guide again to make sure you've followed directions correctly, and to see what might cause variations in cooking time. Cooking guide times and heat settings are suggestions, chosen to help prevent overcooking, the most common problem in getting used to this oven. Variations in the size, shape, weight and dimensions of the food require longer cooking time. Use your own judgment along with the cooking guide suggestions to test food conditions, just as you would do with a conventional cooker.
'Food' on the display. Why doesn't the	When 'Food' appears on the display, the microwave will not operate as it assumes that no food has been placed inside. 'Food' in the display will also appear and the remaining time will be cancelled, if the door is



FAQ	Answer
microwave oven work when 'Food' appears on the display?	opened and closed during cooking and the START button is not pressed within 5 minutes of doing so.
'Cool' appears on the display and the cooling fan continues to run after the cooking or heating time is over.	After cooking is complete, the fan may operate to cool the oven. The display will show 'Cool'. If you open the door or press once STOP before the cooking time is complete, the remaining cooking time will show on the display. This is not a malfunction.

When operating the microwave oven, If you use a product such as radio, TV, wireless LAN, Bluetooth, medical equipment, wireless equipment etc. Using the same frequency as the microwave oven, the product may receive interference from these products. This interference does not indicate a problem of the microwave or the product and is not a malfunction. Therefore, it is safe to use. However, medical equipment may receive interference as well, so use caution when using medical equipment near the product.

Warning

This content is compiled from multiple sources and is provided for reference purposes only. It may not be complete or fully applicable to all situations. If you are unable to resolve your issue, please contact the product manufacturer or an authorized service provider for official support.

