

PRODUCT DESCRIPTION

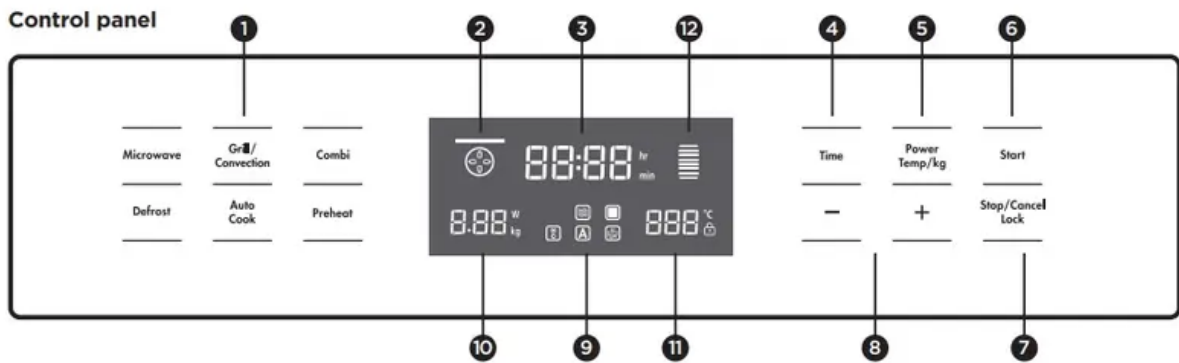
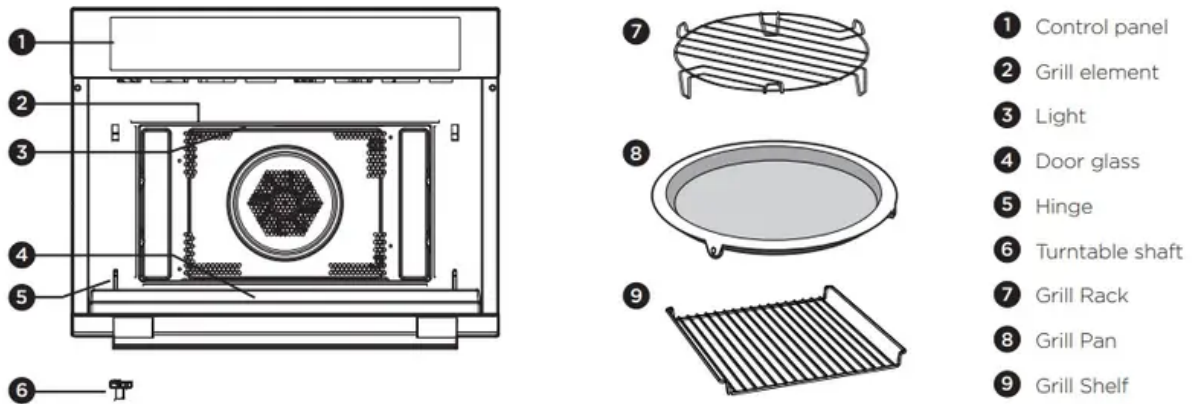

	SYMBOL	FUNCTION	DESCRIPTION
1		Function pads	To set various cooking functions
2		Function display	Displays cooking function active
3		Time display	Displays cooking time or clock function
4		Time	To set clock or cooking time
5		Function pad	To adjust power/ temperature or weight
6		Start	To start or resume a cooking cycle
7		Stop/Cancel/Lock	To stop or reset a cooking function and activate child lock

BEFORE FIRST USE

Initial cleaning and heating

Removing the microwave oven all of the protection foil on the front. For more information see the chapter "CARE AND CLEANING".

Before the first use of the appliance,

- Before any functions can be activated the clock needs to be set. Refer clock setting instructions below.

- Before heating wipe the microwave oven interior with a damp cloth to remove any residual packing material.
- Touch **Grill/Convection** to choose the convection function.
- Default temperature is 180°C. Press **Power Temp/kg** so that temperature flashes, then use + to increase the temperature.
- Raise the temperature to 230°C (maximum temperature). This can be achieved by using beside proximity keys or the numeric keypad.
- Touch **Start** symbol next to the sensor keys. Heat the empty oven for at least an hour.
- When you do this, make sure that the room is well ventilated. Close the door to any other rooms to avoid odor spreading through the house.
- Let the appliance cool down to room temperature.
- Use a solution of neutral detergent mixed with hot water to clean inside the microwave oven, then wipe dry with a clean soft cloth. Keep the door open until the inside of the oven is completely dry.

Clock Setting

When the microwave oven is turned on, "00:00" will blink, buzzer will ring once.

1. Press **-** or **+** to set the right time (between 00:00 and 23:59.)
2. After you have set the right time, press **Time**. The clock has been set.

Changing the time

1. If you want to change the time, you have to press and hold the **Time** button for 3 seconds. The actual time disappears and then the time will blink in the display. Press **-** or **+** to set the new time and press the **Time** button to confirm the setting.
2. When you set the clock, press or when adjusting MIN, short press time (each time you adjust 1MIN).

DAILY USE

WARNING Refer to the safety chapters.

CAUTION Do not let the appliance operate when there is nothing inside.

General information about using the appliance

General:

- After you deactivate the appliance, let the food stand for some minutes.

- Remove the aluminium foil packaging, metal containers, etc before you prepare the food.

Cooling fan:

When the appliance operates, the cooling fan activates automatically to keep the surfaces of the appliance cool. If you deactivate the appliance, the cooling fan can continue to operate until the appliance cools down. Resuming cooking after opening door:

The “start” button must be pressed to continue cooking if the oven door has been opened during cooking process.

Cooking:

- If possible, cook food covered with material suitable for use in the microwave. Only cook food without a cover if you want to keep it crusty.
- Do not overcook the dishes by setting the power and time too high. The food can dry out, burn or catch fire in some places.
- Do not use the appliance to cook eggs or snails in their shells, because they can explode. With fried eggs, pierce the yolks first.
- Prick food with “skin” or “peel”, such as potatoes, tomatoes, sausages, with a fork several times before cooking so that the food does not explode.
- For chilled or frozen food, set a longer cooking time.
- Dishes which contain sauce must be stirred from time to time.
- Vegetables that have a firm structure, such as carrots, peas or cauliflower, must be cooked in water.
- Turn larger pieces after half of the cooking time.
- If possible, cut vegetables into similar sized pieces.
- Use flat, wide dishes.
- Do not use cookware made of porcelain, ceramic or earthenware with small holes, e.g. on handles or unglazed bottoms. Moisture going into the holes can cause the cookware to crack when it is heated.
- The glass cooking tray must be used for heating food or liquids. It is necessary for the operation of the microwave.

Defrosting meat, poultry, fish:

- Put the frozen, unwrapped food on a small upturned plate with a container below it so that the defrosting liquid collects in the container.
- Turn the food after half of the defrosting time. If possible, divide and then remove the pieces that started to defrost.

Defrosting butter, portions of gâteau, soft cheeses:

- Do not fully defrost the food in the appliance, but let it defrost at room temperature. This gives a more even result. Fully remove all metal or aluminium packaging before defrosting.

Defrosting fruit, vegetables:

- Do not fully defrost fruit and vegetables, which are to be further prepared while raw, in the appliance. Let them defrost at room temperature.
- You can use a higher microwave power to cook fruit and vegetables without defrosting them first.

Ready meals:

- You can prepare ready meals in the appliance only if their packaging is suitable for microwave use.
- You must follow the manufacturer's instructions printed on the packaging (e.g. remove the metal cover and pierce the plastic film).

Suitable cookware and materials









COOKWARE / MATERIAL	MICROWAVE			GRILLING/ CONVECTION
	DEFROSTING	HEATING	COOKING	
Ovenproof glass and porcelain (with no metal components, e.g. Pyrex, heat-proof glass)	✓	✓	✓	✓
Non-ovenproof glass and porcelain ¹	✓	--	--	--
Glass and glass ceramic made of ovenproof / frost-proof material (e.g. Arcoflam), grill shelf	✓	✓	✓	✓
Ceramic ² , earthenware ²	✓	✓	✓	--
Heat-resistant plastic up to 200°C ³	✓	✓	✓	--
Cardboard, paper	✓	--	--	--
Clingfilm	✓	--	--	--
Roasting film with microwave safe closure ³	✓	✓	✓	--
Roasting dishes made of metal, e.g. enamel, cast iron	--	--	--	✓
Baking tins, black lacquer or silicon coated ³	--	--	--	✓
Baking tray	--	--	--	✓
Browning cookware, e.g. Crisp pan or Crunch plate	--	✓	✓	--
Ready meals in packaging ³	✓	✓	✓	✓

1. With no silver, gold, platinum or metal plating / decorations.
2. Without quartz or metal components, or glazes which contain metals.
3. You must follow the manufacturer's instructions about the maximum temperatures.

Cooking guide

FOOD	COOKING FUNCTION	TEMP (°C)	MICROWAVE POWER (W)	TIME (MIN)
Scones	Fan Bake	210	N/A	10
Cup Cakes	Fan Bake	180	N/A	17
Sponge cake	Fan Bake	170	N/A	30
Soup	Microwave	N/A	N/A	5 min on 450W then 5 min on 900W
Rice	Microwave	N/A	N/A	5 min on 900W, stir then 5 min on 900W
Pasta	Microwave	N/A	N/A	5 min on 900W, stir then 5 min on 900W
Pizza	Fan Bake	210	N/A	18
Potato Bake	Combi, microwave + Fan Grill	180	700	15
Stuffed zucchini	Microwave + fan grill	180	N/A	10
Chicken wings	Combi, microwave + Fan Grill	180	30	30 (turned every 10)
Roast chicken	Combi, microwave + Fan bake	180	700	20
Roast potato	P03	P03	N/A	P03
Sausages	P04	P04	N/A	P04

Power setting table

FUNCTION		MODE		
Microwave	Microwave		Microwave	Use the microwave function to cook and reheat vegetables, potatoes, rice, fish and meat.
Grill/Convection	Heating		Hot Air	With hot air you can prepare meals in the same way as you do with a conventional oven. The microwave is not activated. You are advised to preheat the oven before putting the meal in the oven.
			Top Grill + Hot Air	Use this function to roast meals evenly and at the same time give the meal a brown crust.
			Top Grill	The grill is ideal to prepare thin pieces of meat and fish.
			Bottom Grill + Hot Air	Bottom grill with fan.
Microwave + Grill/Convection	Combination		Microwave + Hot Air	Use this function to roast meals quickly.
			Microwave + Top Grill + Hot Air	Microwave and grill with fan.
			Microwave + Top Grill	Use this function to cook meals quickly and at the same time give the meal a brown crust (also au gratin). The microwave and the grill are activated at the same time. The microwave is cooking and the grill is roasting.
			Microwave + Bottom Grill + Hot Air	Microwave and grill with fan.
Auto Cook	Auto-programs		P01 - P10	Automatic cooking programs
Defrost	Defrost		d01 + d02	Defrost

AUTOMATIC FUNCTIONS

Microwave Cooking

- Press the **Microwave** button to activate the microwave function. Microwave power, blinks in the display and the microwave icon appears. If no operation in 10 seconds, the current power will be confirmed automatically.
- To adjust the microwave power (between 100W and 900W) use the **—** or **+** buttons.
- Press to set the cooking time. The max. cooking time depends on the power that has been set. When the power is 900W, the MAX. time is 30 minutes and other powers are 90 minutes.
- Press **Start** button to start cooking.

WARNING

Internally the appliance becomes hot when in use. Take care not to touch the grill element when putting in and removing food.









Traditional Cooking functions (without microwave)

1. Press **Grill/Convection**
2. Press **Grill/Convection** or **—** or **+** to select the desired cooking mode.
3. Adjust power/temperature setting as required
 - Grilling: default grill power is 3. Press **Power Temp/kg** then **—** or **+** to adjust from 3 (Max) to 1 (Min) power.
 - Convection: default temperature is 180°C. Press then or to adjust from 50 to 230°C.
NOTE: setting a function below 70°C should be used for plate warming only, not cooking food.
 - Grill with fan: default temperature is 180°C Press **Power Temp/kg** then **—** or **+** to adjust from 100 to 230°C.
4. Press **Time** then **—** or **+** to adjust the time (default is min for grilling and convection).
Max time Grilling is 90 minutes.
Max time convection is 5 hours.
Max time Grill with Fan is 5 hours.
5. Press **Start** to start cooking.







WARNING

Internally the appliance becomes hot when in use. Take care not to touch the grill element when putting in and removing food.

Microwave + Grill Cooking

1. Press **Combi** button to activate the microwave function.
2. Press **Combi Microwave** and  icon will light). Press until the  indicator for grill function is on the display.
3. Press **Power Temp/kg** to enter to the grill power level selection.
4. Press  or  to select the power.
5. To adjust the microwave power press **Power Temp/kg** again until the default microwave power of 300W flashes.
6. Press  or  to select 700W, 450W, 300W and 100W.
7. Press **Time** to select the time setting mode. The default time is 10 minutes.
8. Press  or  or to select the cooking time. The max. time is 90 minutes.
9. Press **Start** button to start cooking.



Microwave + Convection Cooking

1. Press **Combi** to select combination modes. Convection mode is default. The default temperature is 180°C,
2. Press **Power Temp/kg** to enter to the temperature selection.
3. Press  or  to select the temperature between 50 to 230°C.
4. To adjust the microwave power press **Power Temp/kg** again until the default microwave power of 300W flashes.
5. Press  or  to select 700W, 450W, 300W and 100W.
6. Press **Time** to select the time setting mode. The default time is 10 minutes.
7. Press  or  to select the cooking time of grill. The max. time is 90 minutes.
8. Press **Start** button to start cooking.

Microwave + Grill Fan Cooking

WARNING

Internally the appliance becomes hot when in use. Take care not to touch the grill element when putting in and removing food.

1. Press **Combi** button to activate the microwave function.
2. Press **Combi** or **—** or **+** to select the combination mode.  and  will light.
3. Press **Combi** or **—** or **+** to select grill with fan mode. The default temperature is 180°C.  lights.
4. Press **Power Temp/kg** to enter to the temperature selection.
5. Press **—** or **+** to select the temperature between 100 to 230°C.
6. Press **Power Temp/kg** to select the power. The default power is 300W.
7. Press **—** or **+** to select 700W, 450W, 300W and 100W.
8. Press **Time** to select the time setting mode. The default time is 10 minutes.
9. Press **—** or **+** to select the cooking time of grill. The max. time is 90 minutes.
10. Press **Start** button to start cooking.

Auto Cook

There are 12 automatic cooking programs. You only have to choose the program and set the weight. The power, the time and the temperature are already set.

1. Press **Defrost** or **Auto Cook** button to activate the desired microwave program.
2. Press **—** or **+** to select the desired program (“D01” or D02” from defrost, “P01”-“P010” from Auto Cook)
3. Press **Power Temp/kg** button.
4. Press **—** or **+** to select weight of the menu.
5. Press **Start** button to start cooking.

PROGRAM	CATEGORY	ITEM
d01 defrost)**	Meat, poultry and fish	If you hear a beep, the combi microwave oven stops. Turn the food and press the start/pause button to continue the defrosting program.
d02 (defrost)**	Bread, cake and fruit	
P01**	Vegetables	Fresh vegetables
P02**	Side dishes	Potatoes - peeled/cooked
P03*	Side dishes	Potatoes - roasted If you hear a beep, turn the food. The combi microwave oven starts the next phase automatically.
P04	Poultry/Fish	Chicken pieces/ Fish pieces If you hear a beep, turn the food. The combi microwave oven starts the next phase automatically.
P05*	Baking	Cake
P06*	Baking	Apple pie
P07*	Baking	Quiche
P08	Reheat	Drink/soup
P09	Reheat	Plated meal
P10	Reheat	Sauce/stew/dish
P11	Frozen	Pizza
P12	Frozen	Oven chips
P13	Frozen	Lasagne

- The programmes with a * are preheated. During preheating, the cooking time pauses and the preheating symbol is on. After preheating, you will hear an alarm and the preheating symbol will blink. The oven is now ready. After putting what you want to cook in the oven press **Start** to activate the timer.
- The programmes with ** only use the microwave function.

Preheating Function

The preheating function can be activated after you have chosen the functions: Convection, Grill fan, MW-convection, MW-Grill fan.

1. Press **Preheat** button. The preheat icon appears in the display.
2. Press **Start** button to start preheating. Horizontal bars on the right hand side of the time display indicate that the function is operating. If the door is opened the preheating functions stops and the horizontal bars turn off.

NOTE: To recommence a preheating cycle after the door is opened the cooking function and preheating will need to be reprogrammed. Pressing **Start** will immediately commence the cooking function selected. You can also stop the preheating by pressing **Stop/Cancel Lock** the button.

NOTE: The preheating function only works if you have already chosen one of the modes above. During preheating, the microwave function is switched off.

Display Specification

1. After selecting an option it will be confirmed automatically after three seconds.
2. When the oven is in setting or paused state it will revert to off state after 5 min if no operation is selected
3. The oven light will stay on if the door is left open or the oven is paused
4. The **Start** button must be pressed to continue cooking if the oven door is opened during the cooking process

USING THE ACCESSORIES

WARNING

Refer to the safety chapter.

CAUTION

Do not cook food without the turntable set. Only use the turntable set provided with the appliance.

IMPORTANT TIPS & INFORMATION

Never cook food directly on the cooking tray.

Turntable installation

- Never place the enamel tray upside down. The enamel tray should never be restricted.
- The enamel tray must always be used during cooking.
- All food and containers of food should always be placed on the enamel tray for cooking.
- If the enamel tray cracks or breaks, contact your nearest authorised service centre.

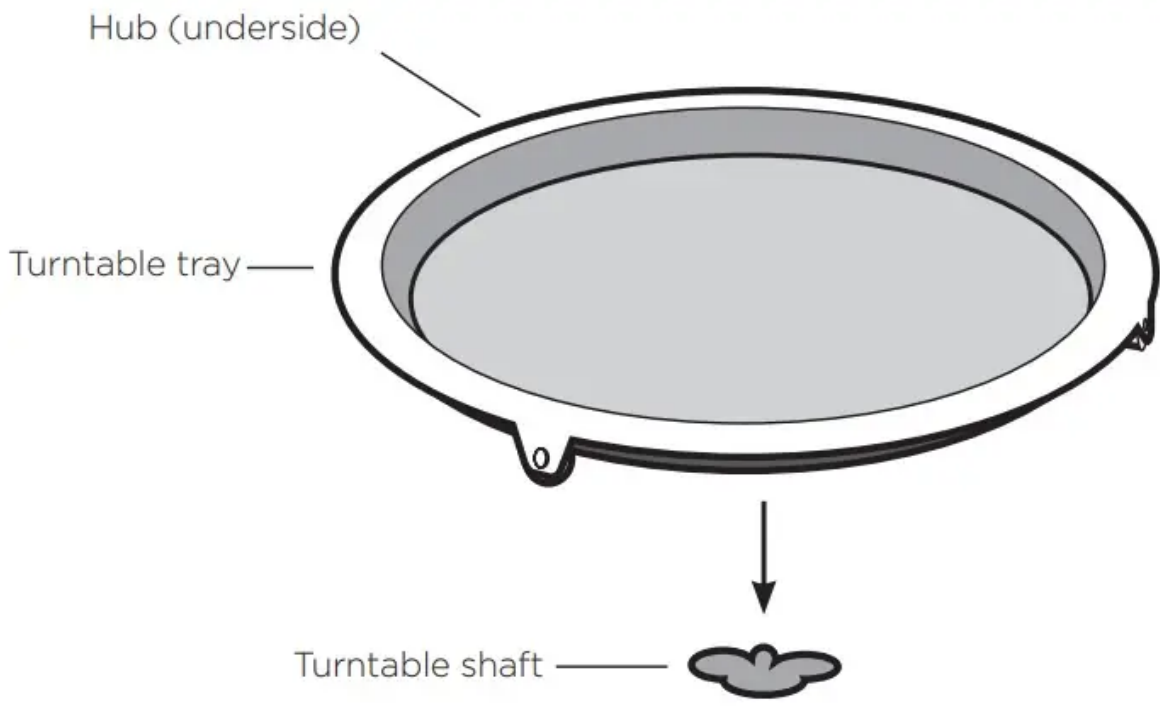

Inserting the grill rack

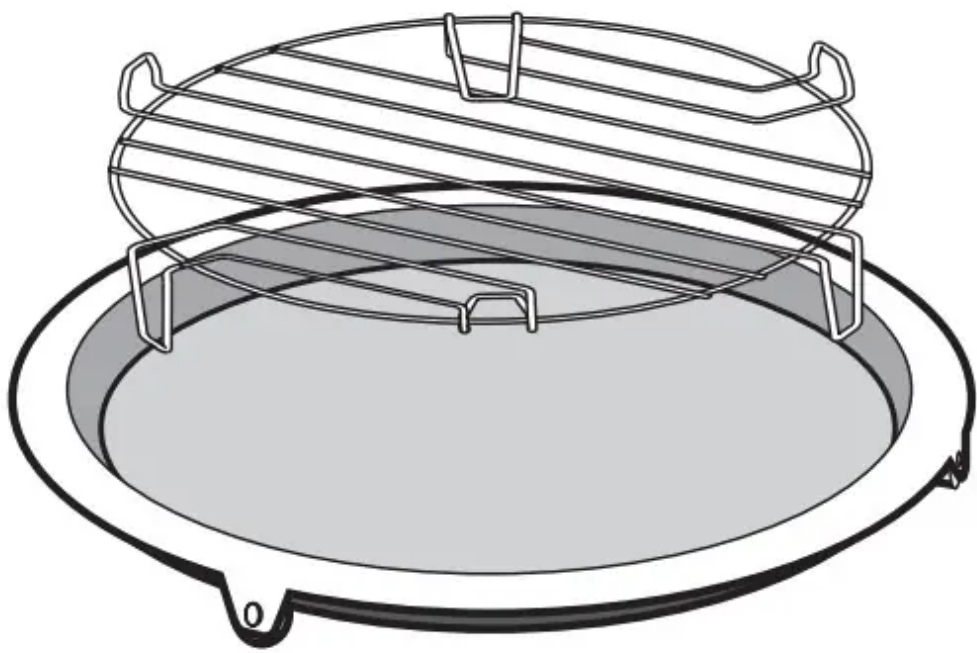

Place the grill rack on the turntable set.

ADDITIONAL FUNCTIONS

Lock-out Function for Children

Lock:



In waiting state, press **Stop/Cancel Lock** for 3 seconds, there will be a long “beep” denoting entering into the children-lock state and  indicator will light.

Unlock:

In locked state, press **Stop/Cancel Lock** for 3 seconds, there will be a long “beep” denoting that the lock is released, and  indicator will disappear.

HELPFUL HINTS AND TIPS

Power setting table

PROBLEM	REMEDY
You cannot find details for the amount of food prepared	Look for a similar food. Increase or shorten the length of the cooking times according to the following rule: Double the amount = almost double the time, Half the amount = half the time
The food got too dry	Set shorter cooking time or select lower microwave power.
The food is not defrosted, hot or cooked after the time came to an end.	Set longer cooking time or set higher power. Note that large dishes need longer time.
After the cooking time comes to an end, the food is overheated at the edge but is still not ready in the middle	Next time set a lower power and a longer time. Stir liquids halfway through, eg. soup.

To get better results for rice use a flat, wide dish.

Defrosting

Always defrost roast with the fat side down. Do not defrost covered meat because this may cause cooking instead of defrosting. Always defrost whole poultry breast side down.

Cooking



Always remove chilled meat and poultry from the refrigerator at least 30 minutes before cooking. Let the meat, poultry, fish and vegetables stay covered after cooking.

Brush a little oil or melted butter over the fish. Add 30- ml of cold water for every 250g of vegetables. Cut the fresh vegetables into even size pieces before cooking.

Cook all vegetables with a cover on the container.

Reheating

When you reheat packed ready meals always follow the instructions written on the packaging.

Grilling

Grill flat food items in the middle of the grill rack. Turn the food over halfway through the set time and continue grilling.

Convection Cooking

You can cook food as in a traditional oven. No microwaves are used.

Combi Cooking

Use the Combi Cooking to keep the crispness of certain foods. At the half of the cooking time, turn over the foods then continue. Each mode combines the microwave, grill and convection functions at different time periods and power levels.

CARE AND CLEANING

WARNING Refer to the safety chapters.

Notes on cleaning:

- To clean the fingerprint-resistant stainless steel front panel, simply wipe with a soft cloth using warm water and a mild detergent. DO NOT use stainless steel cleaners, abrasive cleaners or harsh solvents.
- Clean the appliance interior after each use. You will be able to remove dirt more easily and it will not burn on.
- Clean stubborn dirt with a special cleaner.
- Clean all accessories regularly and let them air dry. Use a soft cloth with warm water and a cleaning agent.
- Boil a glass of water at full microwave power for 2 to 3 minutes to soften and remove dried on remains.
- To remove odours, mix a glass of water with 2 tsp of lemon juice and boil at full microwave power for minutes.

TROUBLESHOOTING



PROBLEM	POSSIBLE CAUSE	REMEDY
The appliance does not operate	<ul style="list-style-type: none"> • The appliance is deactivated. • The appliance is not plugged in. • The fuse in the fuse box is blown. • The door is not closed properly 	<ul style="list-style-type: none"> • Activate the appliance • Plug in the appliance • Check the fuse. If the fuse blows more than one time, contact a qualified electrician. • Make sure that nothing blocks the door.
The light does not operate	<ul style="list-style-type: none"> • The light is defective. 	<ul style="list-style-type: none"> • The light bulb has to be replaced. Contact the customer service centre.
The display shows	<ul style="list-style-type: none"> • The Child Safety Lock is active. 	<ul style="list-style-type: none"> • Deactivate the Child Safety Lock. Hold the Cancel button for 3 seconds.
There is sparking in the cavity	<ul style="list-style-type: none"> • There are metal dishes or dishes with metal trim inside 	<ul style="list-style-type: none"> • Remove the dish from the appliance.
	<ul style="list-style-type: none"> • There are metal skewers or aluminium foil touching the interior walls. 	<ul style="list-style-type: none"> • Make sure that the skewers and foil does not touch the interior walls.
The turntable set makes scratching or grinding noise or	<ul style="list-style-type: none"> • There is an object or dirt below the glass cooking tray 	<ul style="list-style-type: none"> • Clean the area below the glass cooking tray including rollers. Check turntable roller assembly and glass

does not rotate smoothly		are installed correctly. The appliance stops operating without a clear reason.
The appliance stops operating without a clear reason.	<ul style="list-style-type: none"> • There is a malfunction. 	<ul style="list-style-type: none"> • Check ventilation of the unit is not obstructed. If this situation repeats with correct installation, call the customer service centre.
Microwave runs cooking cycle but food does not heat up.	<ul style="list-style-type: none"> • Internal self-resetting thermostat has activated. The microwave is fitted with a thermostat to protect internal components from overheating. 	<ul style="list-style-type: none"> • Once the thermostat's temperature has reduced the unit should function normally. Wait 5 minutes then try the appliance again.
Steam accumulating on microwave oven door or leaking from vents.	<ul style="list-style-type: none"> • Cooking foods with a high moisture content will always produce steam. 	<ul style="list-style-type: none"> • This is a normal part of the cooking process.
Smoke during cooking process.	<ul style="list-style-type: none"> • Fat accumulated on cavity grill element. 	<ul style="list-style-type: none"> • Ensure inside of unit is cleaned regularly.
Cooling fan stays on after cooking function finishes	<ul style="list-style-type: none"> • Activates to keep surfaces of the appliance cool 	<ul style="list-style-type: none"> • No remedy - normal operation of the appliance

If you cannot find a solution to the problem yourself, contact your dealer or the customer service centre. The necessary data for the customer service centre is on the rating plate on the appliance.

We recommend that you write the data at the front of this manual



Warning

This content is compiled from multiple sources and is provided for reference purposes only. It may not be complete or fully applicable to all situations. If you are unable to resolve your issue, please contact the product manufacturer or an authorized service provider for official support.

Document generated by [ManualsFile](#)