

User manual Air Fryer

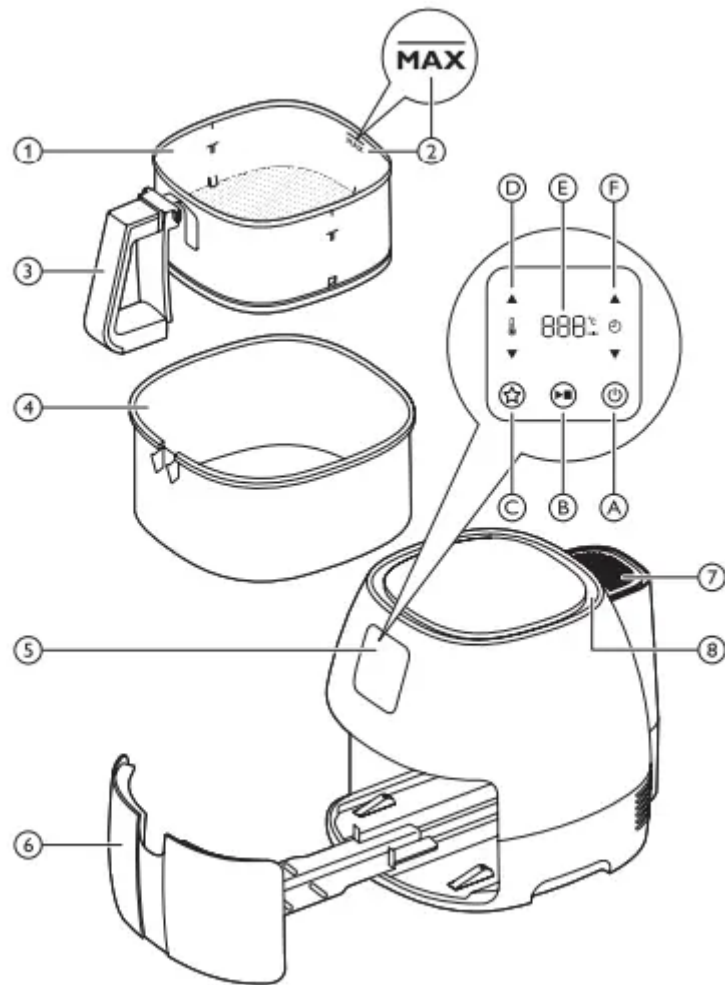

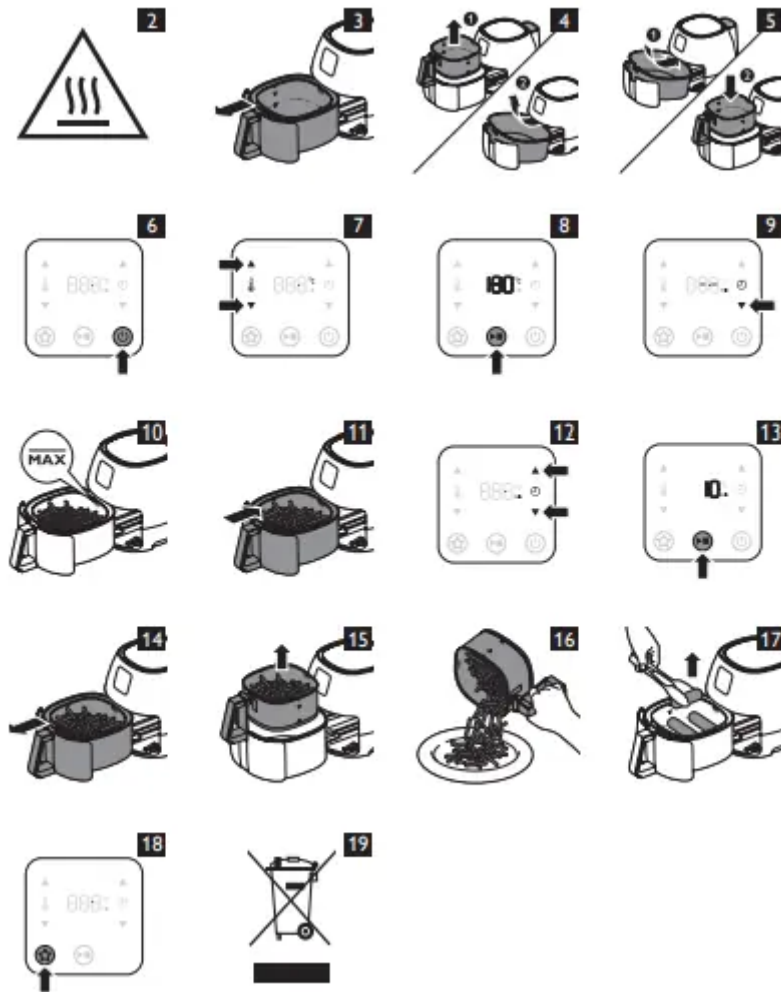

General description

1 Basket

2 MAX indication

3 Basket handle

4 Pan

5 Control panel

A Power on/off button

B START/STOP button

C Preset button

D Temperature increase and decrease buttons

E Time/temperature indication

F Timer increase and decrease buttons

6 Drawer

7 Air outlet openings

8 Air inlet

Important

Read this user manual carefully before you use the appliance and save it for future reference.

Danger

- Never immerse the housing, which contains electrical components and the heating elements, in water nor rinse it under the tap.
- Do not let any water or other liquid enter the appliance to prevent electric shock.
- Always put the ingredients to be fried in the basket, to prevent them from coming into contact with the heating elements.
- Do not cover the air inlet and the air outlet openings while the appliance is operating.
- Do not fill the pan with oil as this may cause a fire hazard.
- Never touch the inside of the appliance while it is operating.

Warning

- Check if the voltage indicated on the appliance corresponds to the local mains voltage before you connect the appliance.
- Do not use the appliance if the plug, the mains cord or the appliance itself is damaged.
- If the mains cord is damaged, you must have it replaced by Philips, a service centre authorised by Philips or similarly qualified persons in order to avoid a hazard.
- This appliance can be used by children aged from 8 years and above and by persons with reduced physical, sensory or mental capabilities or lack of experience and knowledge if they have been given supervision or instruction concerning use of the appliance in a safe way and if they understand the hazards involved.
- Cleaning and user maintenance shall not be made by children unless they are older than 8 and supervised.
- Keep the appliance and its cord out of the reach of children aged less than 8 years.
- Keep the mains cord away from hot surfaces.
- Do not plug in the appliance or operate the control panel with wet hands.
- Only connect the appliance to an earthed wall socket. Always make sure that the plug is inserted into the wall socket properly.
- This appliance is not intended to be operated by means of an external timer or a separate remotecontrol system.

- Do not place the appliance on or near combustible materials such as a tablecloth or curtain.
- Do not place the appliance against a wall or against other appliances. Leave at least 10cm free space at the back, on both sides and above the appliance. Do not place anything on top of the appliance.
- Do not use the appliance for any other purpose than described in this manual.
- Do not let the appliance operate unattended. - During hot air frying, hot steam is released through the air outlet openings. Keep your hands and face at a safe distance from the steam and from the air outlet openings. Also be careful of hot steam and air when you pull the pan out of the appliance.
- The accessible surfaces may become hot during use (Fig. 2).
- Immediately unplug the appliance if you see dark smoke coming out of the appliance. Wait for the smoke emission to stop before you pull the pan out of the appliance.
- The pan becomes hot all over when it is used in the airfryer. Let the pan cool down before you handle it.

Caution

- Place the appliance on a horizontal, even and stable surface.
- This appliance is intended for normal household use only. It is not intended for use in environments such as staff kitchens of shops, offices, farms or other work environments. Nor is it intended to be used by clients in hotels, motels, bed and breakfasts and other residential environments.
- If the appliance is used improperly or for professional or semi-professional purposes or if it is not used according to the instructions in the user manual, the guarantee becomes invalid and Philips refuses any liability for damage caused.
- Always return the appliance to a service centre authorised by Philips for examination or repair. Do not attempt to repair the appliance yourself, otherwise the guarantee becomes invalid.
- Always unplug the appliance after use.
- Let the appliance cool down for approx. 30 minutes before you handle or clean it.
- Make sure the ingredients prepared in this appliance come out golden-yellow instead of dark or brown. Remove burnt remnants. Do not fry fresh potatoes at a temperature above 180°C (to minimise the production of acrylamide).

Automatic switch-off: This appliance is equipped with an automatic switch-off. If you do not press a button within 30 minutes, the appliance switches off automatically. To switch off the appliance manually, press the power on/off button.

Electromagnetic fields (EMF): This Philips appliance complies with all standards regarding electromagnetic fields (EMF). If handled properly and according to the instructions in this user manual, the appliance is safe to use based on scientific evidence available today.

Before first use

1. Remove all packaging material.
2. Remove the foil from the control panel and any stickers or labels from the appliance.
3. Open the drawer by pulling at the handle.
4. Remove the basket by lifting the handle (1). To remove the pan, tilt it backwards and lift it off the rails (2).
5. Thoroughly clean the basket and pan with hot water, some washingup liquid and a non-abrasive sponge. Note: You can also clean these parts in the dishwasher.
6. Wipe the inside and outside of the appliance with a moist cloth.
7. Place the pan in the drawer (1) and put the basket in the pan (2)
8. Slide the drawer back into the airfryer by the handle

Preparing for use

- 1 Place the appliance on a stable, horizontal and level surface.
 - Do not place the operating appliance on non-heat-resistant surfaces.
 - Do not place the operating appliance near or underneath objects that could be damaged by steam, such as walls and cupboards.
 - Note: Place the appliance on a worktop in such a way that the drawer can be opened completely.
- 2 Pull the mains cord out of the cord storage compartment at the back of the appliance.
 - This airfryer works on hot air. Do not fill the pan with oil, frying fat or any other liquid.
 - Do not put anything on top of the appliance. This disrupts the airflow and affects the hot air frying result.

Using the appliance

The airfryer can prepare a large range of ingredients. The recipe booklet included helps you get to know the appliance. You can find more recipes at www.philips.com/kitchen.

Preheating

- 1 Put the mains plug in an earthed wall socket.

2 Press the power on/off button to switch on the appliance. (Fig. 6) , The display shows the last selected temperature.

3 Press the temperature increase or decrease button to set the required temperature. See section 'Settings' in this chapter to determine the right temperature. (Fig. 7)

- Tip: Press the increase or decrease button longer to put the temperature forward or backward more quickly.
- Note: If you do not want to preheat, but want to start frying immediately, skip step 4 and follow the instructions in section 'Hot air frying' in this chapter.

4 Press the START/STOP button. (Fig. 8)

- The appliance starts to heat up.
- The set temperature flashes until the set temperature has been reached. Then the appliance beeps and the set temperature is displayed continuously. The appliance stops beeping if you set the required cooking time (see step 4 in section 'Hot air frying').

Note: You can also start the preheating process manually by setting the temperature and then pressing the timer decrease button until '- ' appears

Hot air frying

1 Open the drawer by pulling at the handle. (Fig. 3)

2 Put the ingredients in the basket (Fig. 10).

- Note: Never fill the basket beyond the MAX indication or exceed the amount indicated in the table (see section 'Settings' in this chapter), as this could affect the quality of the end result.

3 Slide the drawer back into the airfryer by the handle (Fig. 11).

- Never use the pan without the basket in it. If you heat up the appliance without basket, use oven gloves to open the drawer. The edges and inside of the drawer become very hot.
- Caution: Do not touch the pan during and some time after use, as it gets very hot.

4 Press the timer increase or decrease button to set the timer to the required cooking time. See section 'Settings' in this chapter to determine the correct cooking time. (Fig. 12)

- Tip: Press the timer increase or decrease button longer to put the time forward or backward more quickly.
- Note: If you have not preheated the appliance, add 3 minutes to the cooking time.
- Note: If you do not set the required cooking time within 5 minutes, the appliance switches off automatically for safety reasons.

5 Press the START/STOP button to start the cooking process. (Fig. 13)

- The display starts counting down the set cooking time.
- Excess oil from the ingredients is collected on the bottom of the pan.

6 When the appliance starts to beep, the set cooking time has elapsed.

- Note: You can also stop the cooking process manually. To do this, press the START/STOP button (Fig. 8).

7 Open the drawer by pulling at the handle and check if the ingredients are ready. (Fig. 14)

- If the ingredients are not ready yet, simply slide the drawer back into the airfryer by the handle and add a few extra minutes to the set time.

8 To remove small ingredients (e.g. fries), lift the basket out of the pan by the handle. (Fig. 15)

- After the cooking process, the pan, the basket and the ingredients are hot. Depending on the type of ingredients in the airfryer, steam may escape from the pan.

9 Empty the basket into a bowl or onto a plate. (Fig. 16)

- Tip: To remove large or fragile ingredients, use a pair of tongs to lift the ingredients out of the basket (Fig. 17).

10 When a batch of ingredients is ready, the airfryer is instantly ready for preparing another batch.

- Note: Repeat steps 1 to 9 if you want to prepare another batch.
- Note: If you prepare another batch within 30 minutes, it is not necessary to preheat the appliance again.

11 Press the power on/off button to switch off the airfryer.

Preset button

You can program the appliance to prepare your favourite ingredients at a specific temperature for a specific length of time.

Note: The appliance can only memorise one temperature and one cooking time. To set your favourite settings:

1 Press the power on/off button to switch on the appliance. (Fig. 6)

2 Press the preset button (star symbol). (Fig. 18)

- The display shows the current saved settings.

3 Press the temperature increase or decrease button to set the desired temperature. (Fig. 7)

- The star symbol starts flashing.

4 Press the timer increase or decrease button to set the desired time. (Fig. 12)

5 Press the preset button (star symbol). (Fig. 18)

- You hear a beep and the star symbol lights up continuously to indicate that the settings have been saved.

From now on, the appliance memorises your favourite settings. Just press the preset button to recall the saved settings. Press the START/STOP button to start the program.

Note: If you want to change the saved settings, simply perform steps 1 to 5 again.

Settings

- The table below helps you to select the basic settings for the ingredients you want to prepare.
- Note: Keep in mind that these settings are indications. As ingredients differ in origin, size, shape as well as brand, we cannot guarantee the best setting for your ingredients.
- Because the Rapid Air technology instantly reheats the air inside the appliance, pulling the pan briefly out of the appliance during cooking barely disturbs the process.
- Tips
 - Smaller ingredients usually require a slightly shorter cooking time than larger ingredients.
 - A larger amount of ingredients only requires a slightly longer cooking time, a smaller amount of ingredients only requires a slightly shorter cooking time.
 - Shake smaller ingredients halfway through the cooking time to redistribute them. This improves the end result and helps to prevent unevenly cooked ingredients.
 - Add some oil to fresh potatoes for a crispy result. Fry your ingredients in the airfryer within a few minutes after you added the oil.
 - Do not prepare extremely greasy ingredients such as sausages in the airfryer.
 - Snacks that can be prepared in an oven can also be prepared in the airfryer.
 - The optimal amount for preparing crispy fries is 750 grams.
 - Use pre-made dough to prepare filled snacks quickly and easily. Pre-made dough also requires a shorter cooking time than home-made dough.
 - Place a baking tray or oven dish in the airfryer basket if you want to bake a cake or quiche or if you want to fry fragile ingredients or filled ingredients.
 - You can also use the airfryer to reheat ingredients. To reheat ingredients, set the temperature to 150°C for up to 10 minutes.

	Min-max amount (g)	Cooking time (min.)	Temperature (°C)	Shake	Extra information
Potatoes & fries					
Thin frozen fries	300g-1000g	8-16	200	Shake	
Thick frozen fries	300g-1000g	13-19	200	Shake	
Home-made fries (8x8mm)	300g-1200g	20-30	180	Shake	add 1/2 tbsp of oil
Home-made potato wedges	300g-900g	18-24	180	Shake	add 1/2 tbsp of oil
Snacks					
Spring rolls	100g-400g	7	200	Shake	Use oven-ready
Frozen chicken nuggets	400g	6	200	Shake	Use oven-ready
Frozen fish fingers	4-12	8-10	200		Use oven-ready
Roasted vegetables	750g	15	200		
Meat rolls	1-5	6	200		
Hamburger	100g - 400g	6-7	180		
Baking					
Cake	500g	50	150		Use baking tray
Quiche	400g	20	190		Use baking tray/oven dish
Muffins	400g	15	180		Use baking tray
	Min-max Amount (g)	Cooking time (min.) at temperature (°C)			
Meat & poultry					
Steak*	100g	5 at 180°C and 4 at 100°C			
	600g	6 at 180°C and 4 at 100°C			
Drumsticks*	1 (80g)	10 at 200°C and 10 at 150°C			
	7 (600g)	10 at 200°C and 10 at 150°C			
Chicken breast*	100g	8 at 140°C and 6 at 180°C			
	800g	8 at 140°C and 8 at 180°C			

* Always start cooking at the highest temperature and then continue at a lower temperature until done.

Note: When you use ingredients that rise (such as with cake, quiche or muffins) the baking tray should not be filled more than halfway

Note: The cooking time does not include the time needed for preheating the appliance

Making home-made fries

For the best results, we advise you to use pre-baked (e.g. frozen) fries. If you want to make home-made fries, follow the steps below.

1. Peel the potatoes and cut them into sticks.
2. Soak the potato sticks in a bowl for at least 30 minutes, take them out and dry them with kitchen paper.
3. Pour ½ tablespoon of olive oil in a bowl, put the sticks on top and mix until the sticks are coated with oil.
4. Remove the sticks from the bowl with your fingers or a kitchen utensil so that excess oil stays behind in the bowl. Put the sticks in the basket.

Note: Do not tilt the bowl to put all the sticks in the basket in one go, to prevent excess oil from ending up on the bottom of the pan. 5 Fry the potato sticks according to the instructions in this chapter.

Cleaning

Clean the appliance after every use. Remove oil from the bottom of the pan after each cooking process to prevent the development of smoke.

Open the drawer to let the airfryer cool down more quickly. Let the pan cool down before you remove it from the appliance.

The pan, basket and the inside of the appliance have a non-stick coating. Do not use metal kitchen utensils or abrasive cleaning materials to clean them, as this may damage the non-stick coating.

1. Remove the mains plug from the wall socket and let the appliance cool down.
2. Wipe the outside of the appliance with a moist cloth. Note: Make sure no moisture remains behind on the control panel. Dry the control panel with a cloth after you have cleaned it.
3. Clean the pan and the basket with hot water, some washing-up liquid and a non-abrasive sponge. You can use a degreasing liquid to remove any remaining dirt. Note: The pan and basket are dishwasher-proof. Tip: If dirt sticks to the basket or the bottom of the pan, fill the pan with hot water with some washing-up liquid. Put the basket in the pan and let the pan and the basket soak for approximately 10 minutes.
4. Clean the inside of the appliance with hot water and a non-abrasive sponge.
5. Clean the heating element with a cleaning brush to remove any food residues

Storage

1. Unplug the appliance and let it cool down.

2. Make sure all parts are clean and dry.
3. Insert the cord into the cord storage compartment.

Troubleshooting

This chapter summarises the most common problems you could encounter with the appliance. If you are unable to solve the problem with the information below, visit www.philips.com/support for a list of frequently asked questions or contact the Consumer Care Centre in your country

1. The appliance does not work.

- The appliance is not plugged in.
 - Put the mains plug in an earthed wall socket.
- The appliance is not switched on.
 - Press the power on/off button to switch on the appliance.

2. The ingredients fried with the appliance are not done.

- The set temperature is too low.
 - Press the temperature increase button to set the required temperature (see section 'Settings' in chapter 'Using the appliance').
- The cooking time is too short.
 - Press the timer increase button to set the required cooking time (see section 'Settings' in chapter 'Using the appliance')
- The amount of ingredients in the basket is too big.
 - Put smaller batches of ingredients in the basket. Smaller batches are fried more evenly. Do not exceed the MAX indication or the maximum amount in the table

3. The ingredients are fried unevenly in the appliance.

- Certain types of ingredients need to be shaken halfway through the cooking time.
 - Ingredients that lie on top of or across each other (e.g. fries) need to be shaken halfway through the cooking time. See section 'Settings' in chapter 'Using the appliance'

4. Fried snacks are not crispy when they come out of the appliance.

- You used a type of snacks meant to be prepared in a traditional deep fryer.
 - Use oven snacks or lightly brush some oil onto the snacks for a crispier result.

5. I cannot slide the drawer into the appliance properly.

- There are too many ingredients in the basket.
 - Do not fill the basket beyond the MAX indication.
- The pan and the basket are not placed correctly.
 - Make sure the pan and basket are placed correctly

6. White smoke comes out of the appliance.

- You are preparing greasy ingredients.
 - When you fry greasy ingredients in the appliance, a large amount of oil will leak into the pan. The oil produces white smoke and the pan may heat up more than usual. This does not affect the appliance or the end result.
- The pan still contains grease residues from previous use.
 - White smoke is caused by grease heating up in the pan. Make sure you clean the pan properly after each use

7. Fresh fries are fried unevenly in the appliance.

- You did not soak the potato sticks properly before you fried them.
 - Soak the potato sticks in a bowl for at least 30 minutes, take them out and dry them with kitchen paper.
- You did not use the right potato type.
 - Make sure you use fresh potatoes and a firm type of potatoes.

8. Fresh fries are not crispy when they come out of the appliance.

- The crispiness of the fries depends on the amount of oil and water in the fries.
 - Make sure you dry the potato sticks properly before you add the oil. Cut the potato sticks smaller and add slightly more oil for a crispier result.

9. The message 'Er' appears on the display.

- An error has occurred.
 - Have the appliance checked by a service centre authorised by Philips.

10. The time and temperature indications change automatically, even though I do not press any buttons.

- There is moisture on the control panel.
 - Make sure you dry the control panel with a cloth after you have cleaned it.

Warning

This content is compiled from multiple sources and is provided for reference purposes only. It may not be complete or fully applicable to all situations. If you are unable to resolve your issue, please contact the product manufacturer or an authorized service provider for official support.

Document generated by [ManualsFile](#)