

Description

General Description

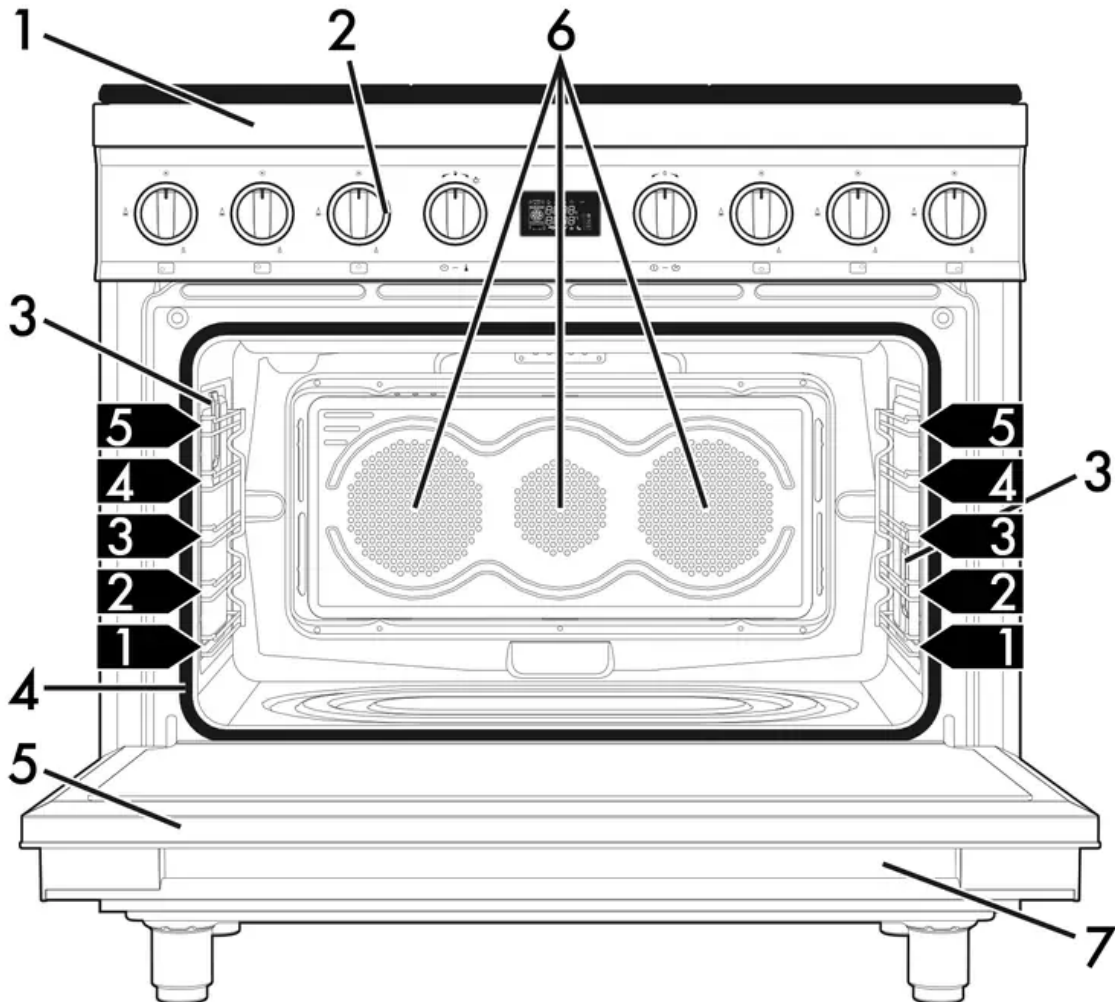

- 1. Cooking hob
- 2. Control panel
- 3. Oven light
- 4. Seal
- 5. Door
- 6. Fan
- 7. Storage compartment

1, 2, 3,... Rack/tray support frames

Cooking hob

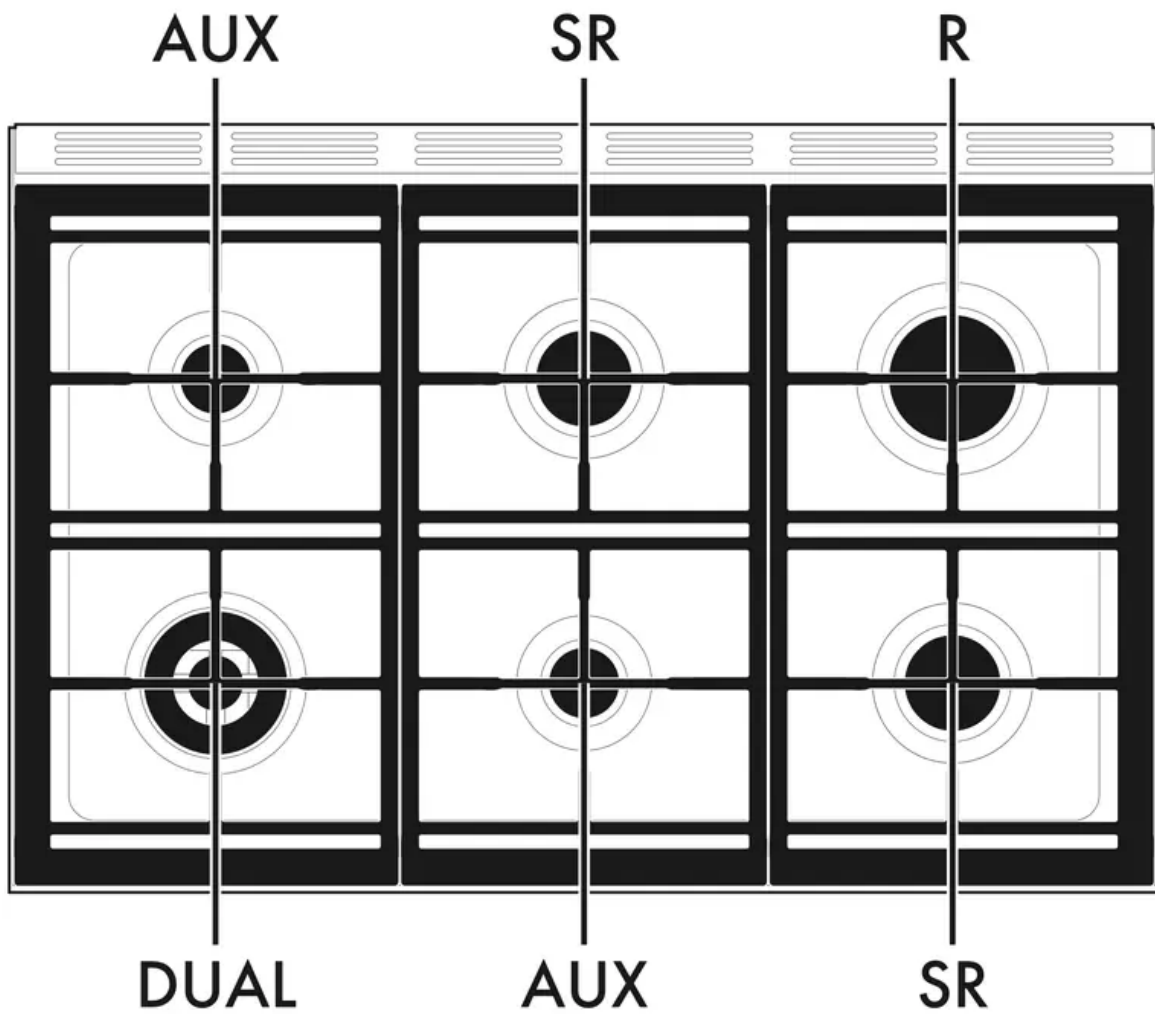

AUX = Auxiliary

SR = Semi-rapid

R = Rapid

DUAL = Ultra-rapid

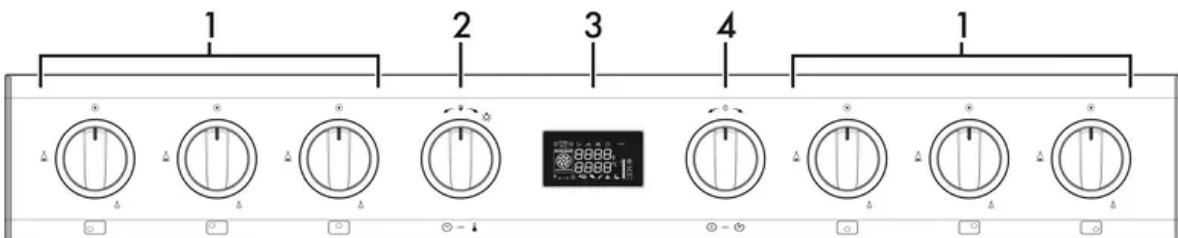

Control panel



1. Hob burner knobs

Used for lighting and adjusting the hob burners.

Press and turn the knobs anti-clockwise to  in order to light the relative burners.

Turn the knobs to the zone between the maximum  and minimum  setting to adjust the flame.

Return the knobs to the position  to turn off the burners.

2. Temperature knob

This knob allows you to select the cooking time and temperature, set programmed cooking and the current time as well as turn the light inside the oven on and off.

3. Display

Displays the current time, the selected cooking temperature and function and any time set.

4. Function knob

This knob allows you to turn the appliance on and off and select the cooking function.

Other parts

Cooling fan

The fan cools the oven and comes into operation during cooking.

The fan causes a steady outflow of air that exits from the rear of the appliance and which may continue for a brief period of time even after the appliance has been turned off.

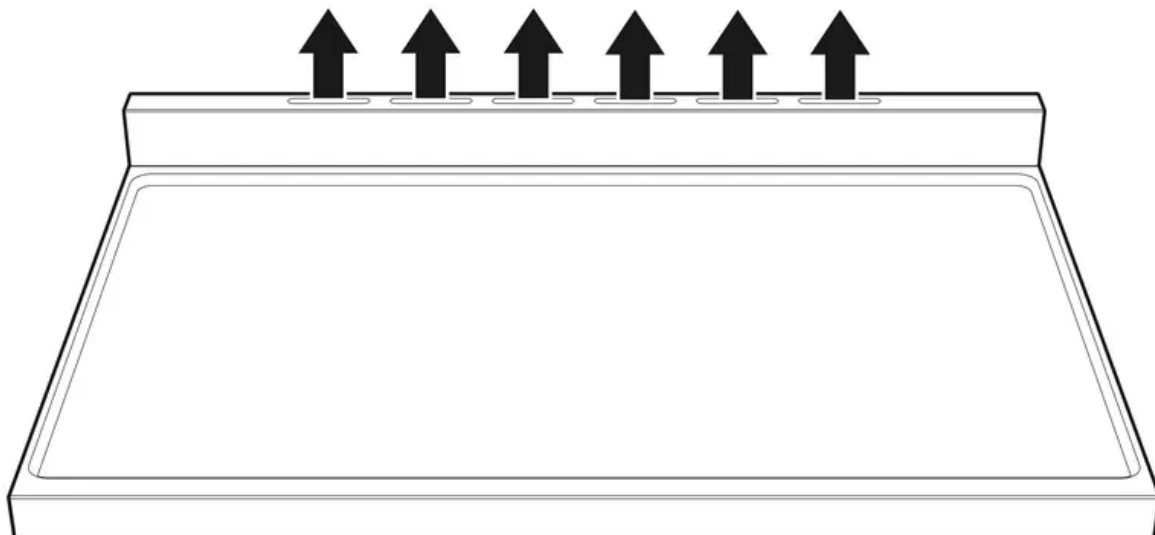

Note: Do not obstruct ventilation openings and heat dispersal slots.

Interior lighting

The appliance's interior lighting comes on:

- When the door is opened.

-

When any function is selected, apart from the



+

and

functions (multifunction models), and the



and



functions (pyrolytic models).

- When the temperature knob is briefly turned to the right (manual activation and deactivation).

Note: When the door is open, it is not possible to turn off the interior lighting.

Shelves

The appliance features shelves to position trays and racks at different heights. The insertion heights are indicated from the bottom upwards (see 2.1 General Description).

Available accessories

WOK ring

Useful when using a wok.

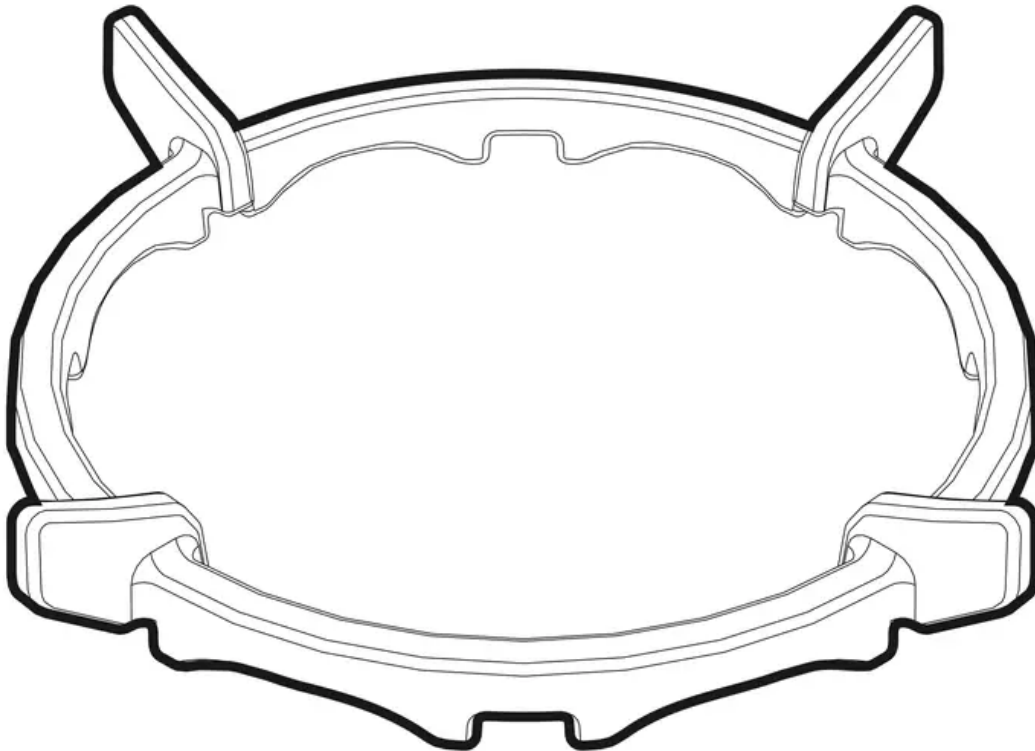

Tray rack

To be placed over the top of the oven tray; for cooking foods which may drip.

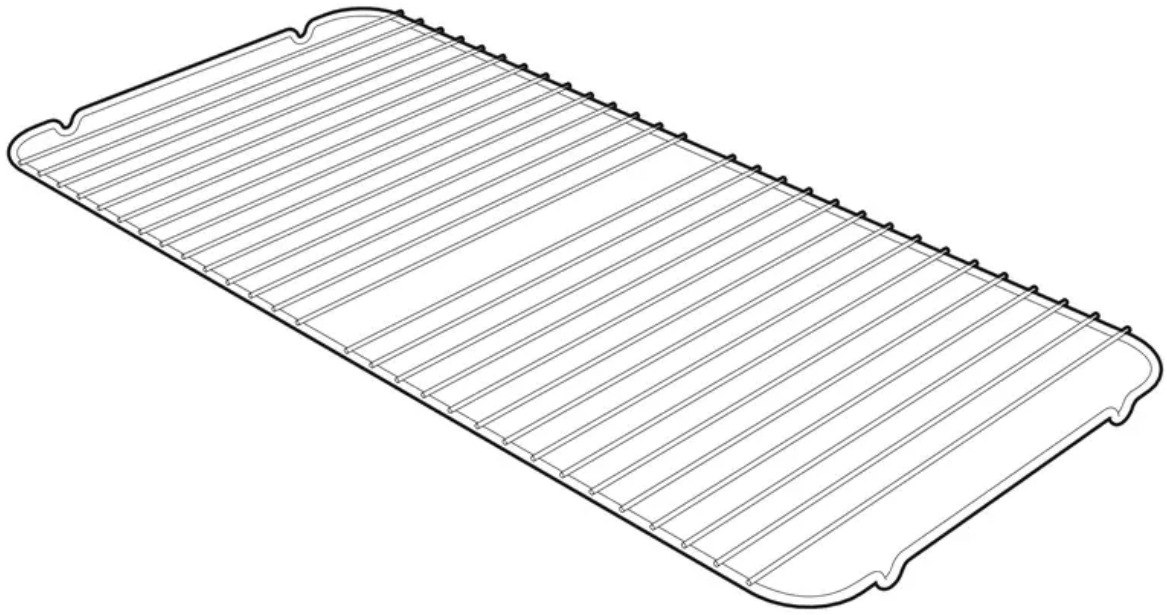

Oven tray

Useful for collecting fat from foods placed on the rack above.

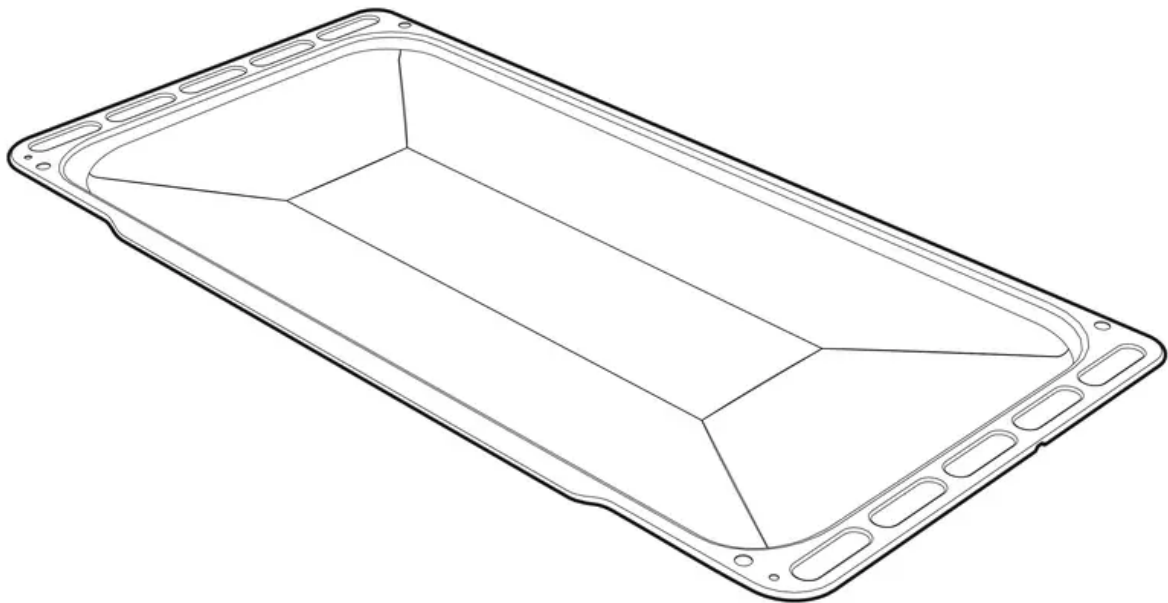

Deep tray

Useful for collecting fat from foods placed on the rack above and for cooking pies, pizzas and baked desserts.



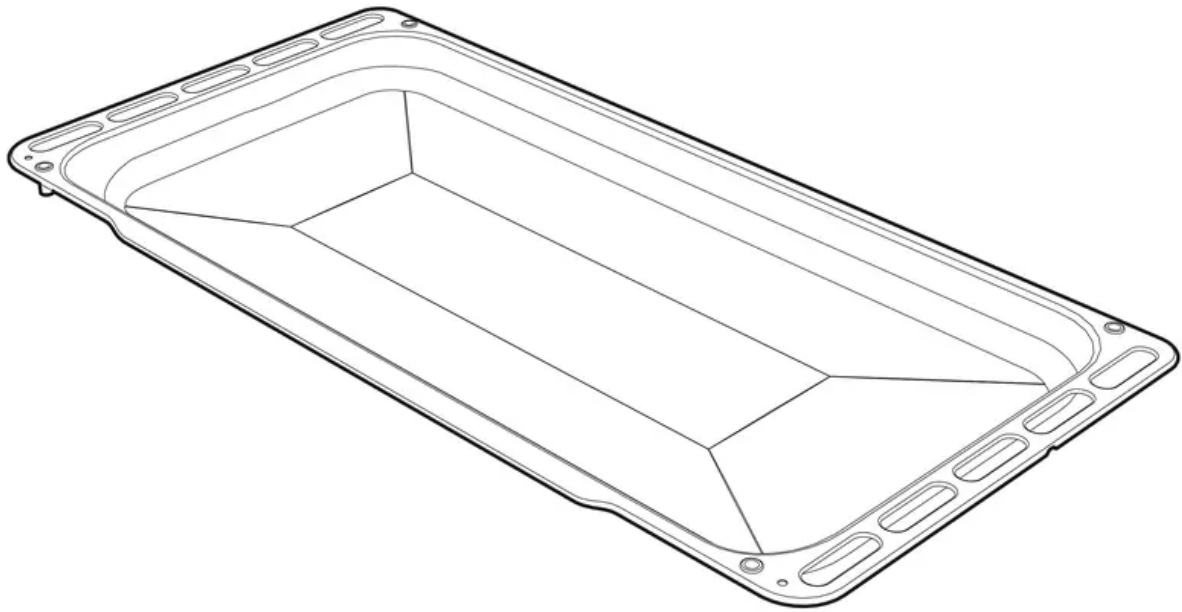

Rack

Useful for supporting containers with food during cooking.

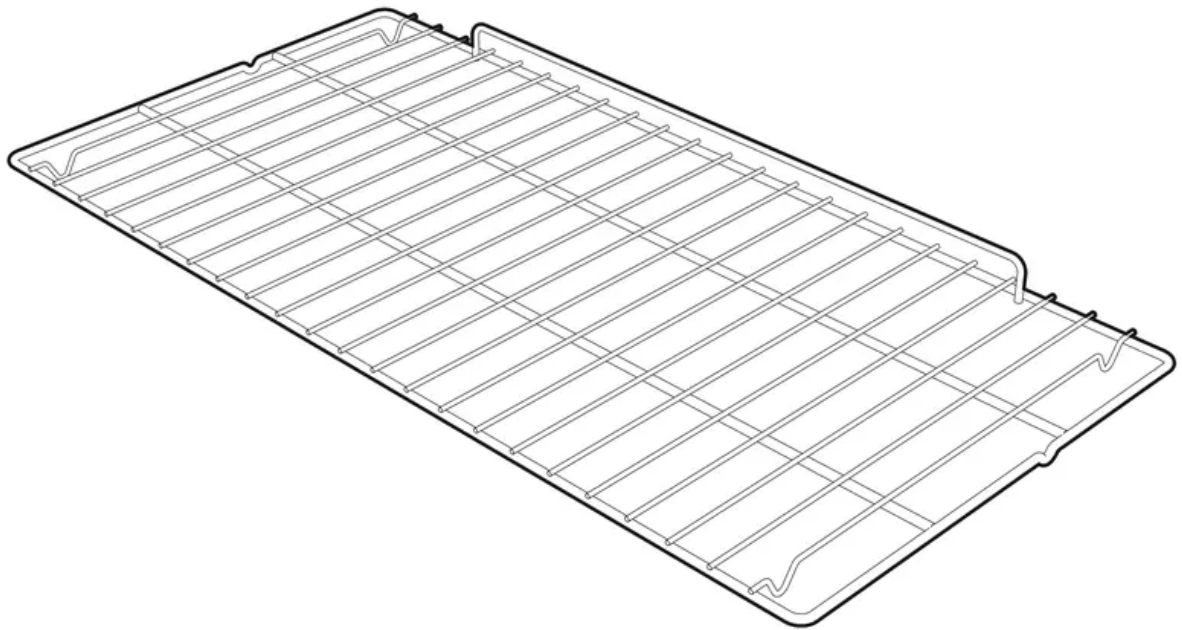

Rotisserie (on some models only)

Useful for cooking chicken and all foods which require uniform cooking over their entire surface.

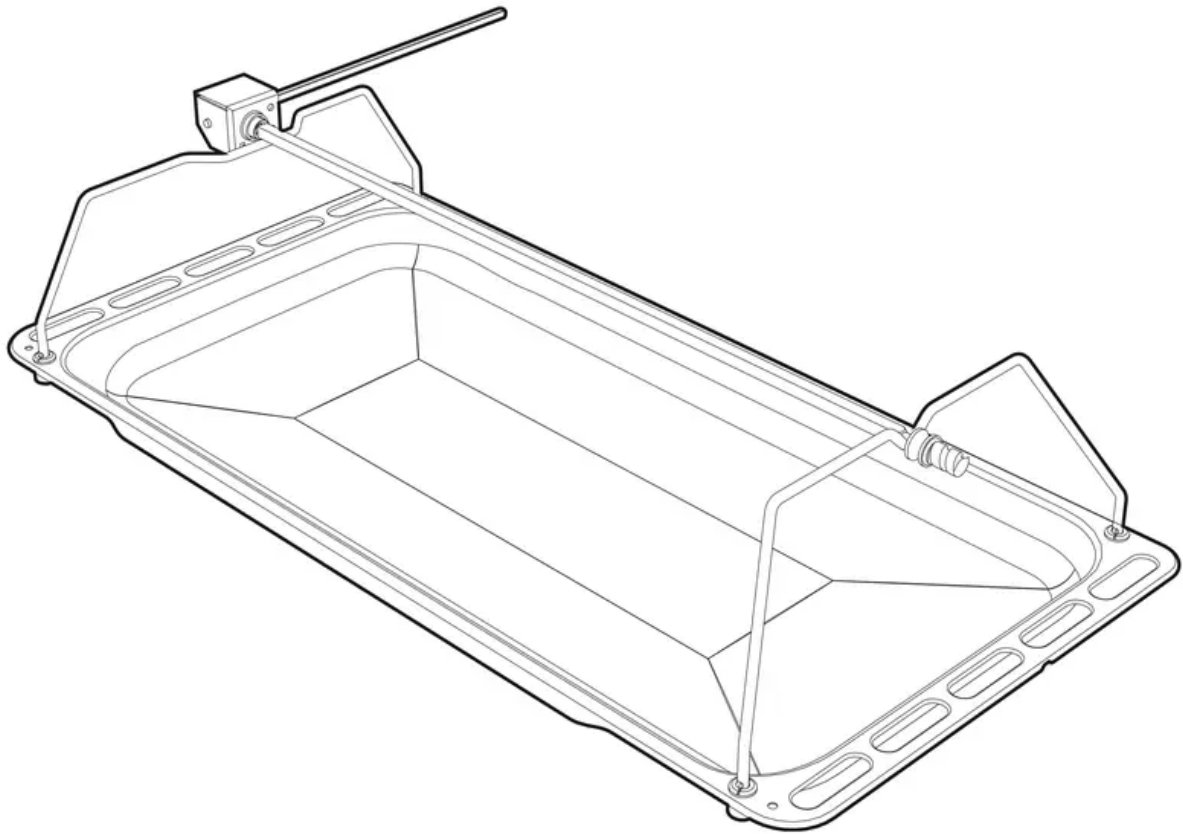

Note: Some models are not provided with all accessories.

Note: The accessories intended to come into contact with food are made of materials that comply with the provisions of current legislation.

Note: Supplied and optional accessories can be requested to Authorised Assistance Centres. Use only original accessories supplied by the manufacturer.

Use

Instructions

Caution: High temperature inside the oven during use - Danger of burns

- Keep the oven door closed during cooking.
- Protect your hands by wearing oven gloves when moving food inside the oven.
- Do not touch the heating elements inside the oven.
- Do not pour water directly onto very hot trays.
- Keep children under the age of 8 away from the appliance when it is in use.
- If you need to move food or at the end of cooking, open the door 5 cm for a few seconds, let the steam come out, then open it fully.

Caution: Improper use - Danger of burns

- Make sure that the flame-spreader crowns are correctly positioned in their seats with their respective burner caps.
- Oils and fats could catch fire if overheated. Be very careful.

Caution: Improper use - Risk of damage to surfaces

- Do not cover the bottom of the oven cavity with aluminium or tin foil sheets.
- If you wish to use greaseproof paper, place it so that it will not interfere with the hot air circulation inside the oven.
- Do not place pans or trays directly on the bottom of the oven cavity.
- Do not use the open door to rest pans or trays on the internal glass pane.
- Do not pour water directly onto very hot trays.
- Cooking vessels or griddle plates should be placed inside the perimeter of the hob.
- All pans must have smooth, flat bottoms.
- If any liquid does boil over or spill, remove the excess from the hob.

Caution: High temperature inside the storage compartment - Danger of burns

- Do not open the storage compartment when the appliance is on and still hot.
- The items inside the storage compartment could be very hot after using the appliance.

Caution: High temperature inside the oven during use - Danger of fire or explosion

- Do not spray any spray products near the appliance.
- Do not use or leave flammable materials near the appliance or the storage compartment.
- Do not use plastic cookware or containers when cooking food.
- Do not put sealed tins or containers in the oven.
- Do not leave the appliance unattended during cooking operations where fats or oils could be released.
- Remove all trays and racks which are not required during cooking.

A gas leak can cause an explosion.

If you smell gas or there are faults in the gas system:

- Immediately turn off the gas supply or close the valve on the gas cylinder.
- Extinguish all naked flames and cigarettes.
- Do not turn on power switches or appliances and do not remove plugs from power sockets. Do not use phones or mobile phones inside the building.
- Open the window in order to ventilate the room.
- Call customer assistance services or your gas supplier.

Malfunctions

Any of the following indicate a malfunction and you should contact a service centre.

- Yellowing of the burner plate.
- Damage to kitchen utensils.
- The burners do not ignite properly.
- It is difficult to keep the burners lit.
- The burners go out when the appliance is in use.
- It is difficult to turn the gas valves.

If the appliance does not work properly, contact your local Authorised Service Centre.

First use

1. Remove any protective film from the outside or inside of the appliance, including accessories.
2. Remove any labels (apart from the technical data plate) from the accessories and from the oven cavity.
3. Remove and wash all the appliance accessories (see 4 Cleaning and maintenance).
4. Heat the empty appliance to the maximum temperature to burn off any residues left by the manufacturing process.

Using the accessories

Ring reducers

The ring reducers must be placed on the hob grids. Make sure they are placed properly.

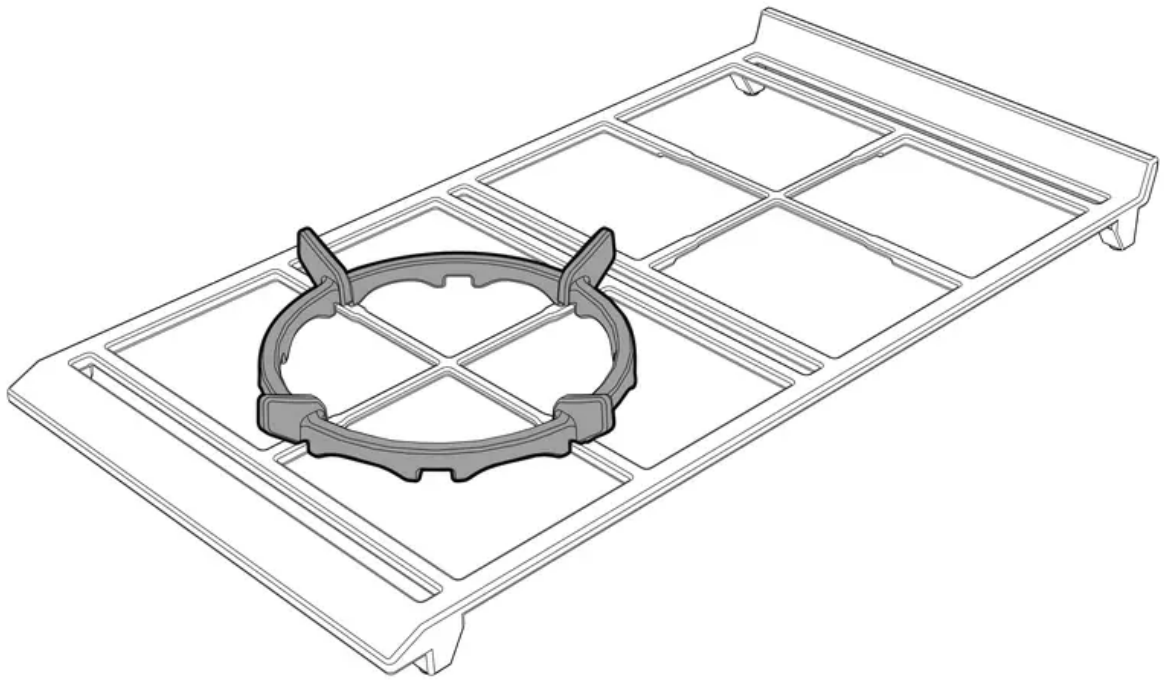

Tray rack

The tray rack has to be inserted into the tray. In this way fat can be collected separately from the food which is being cooked.

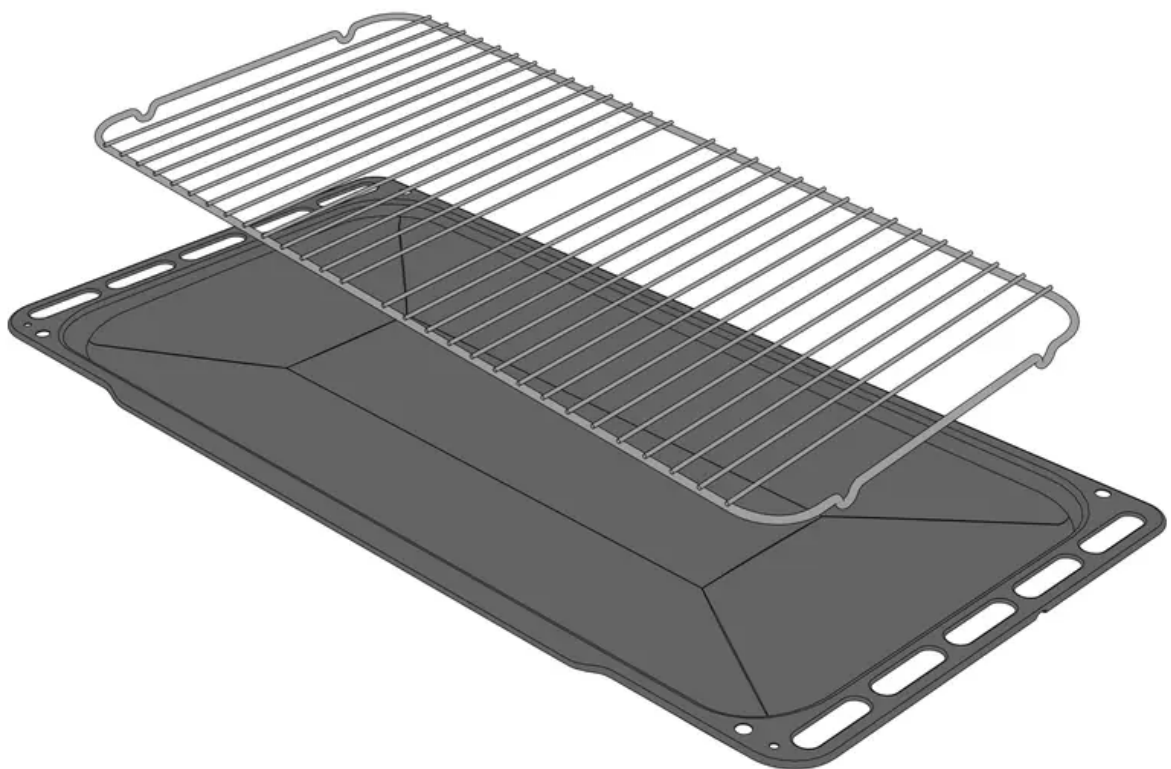

Racks and trays

Racks and trays have to be inserted into the side guides until they come to a complete stop.

The mechanical safety locks that prevent the rack from being taken out accidentally have to face downwards and towards the oven back.

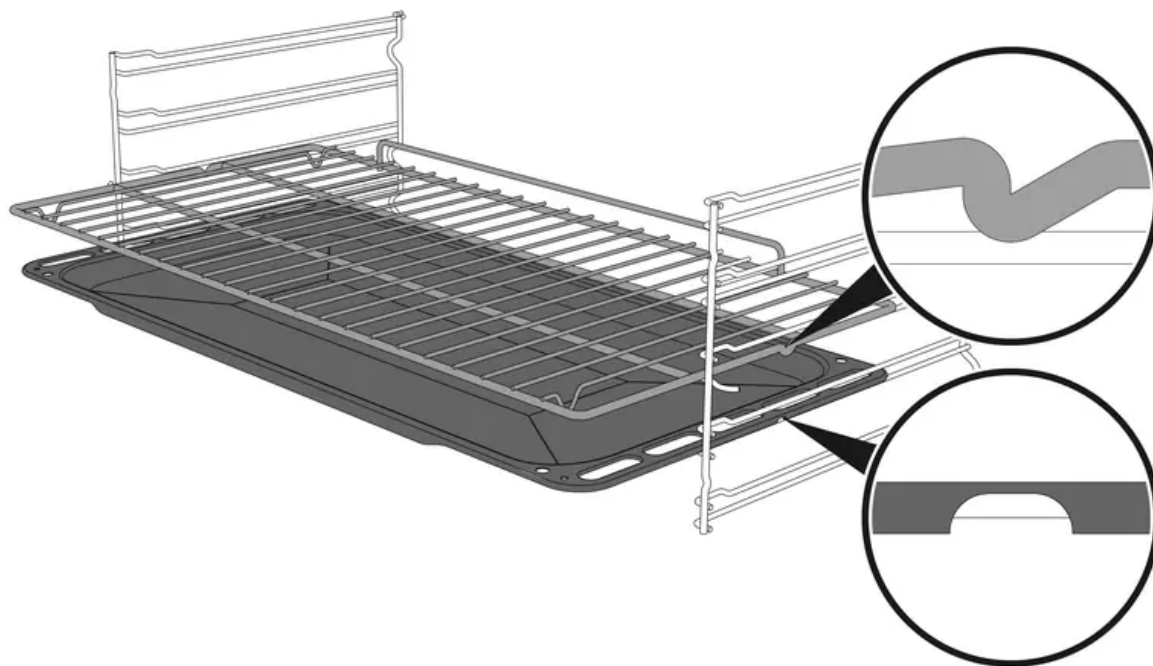

Note: Gently insert racks and trays into the oven until they come to a stop.

Note: Clean the trays before using them for the first time to remove any residues left by the manufacturing process.

Rotisserie (on some models only)

1. Insert the 4 supplied bushings in the 4 corner holes of the deep tray and screw them onto the ring nuts with a suitable tool (such as a screwdriver).

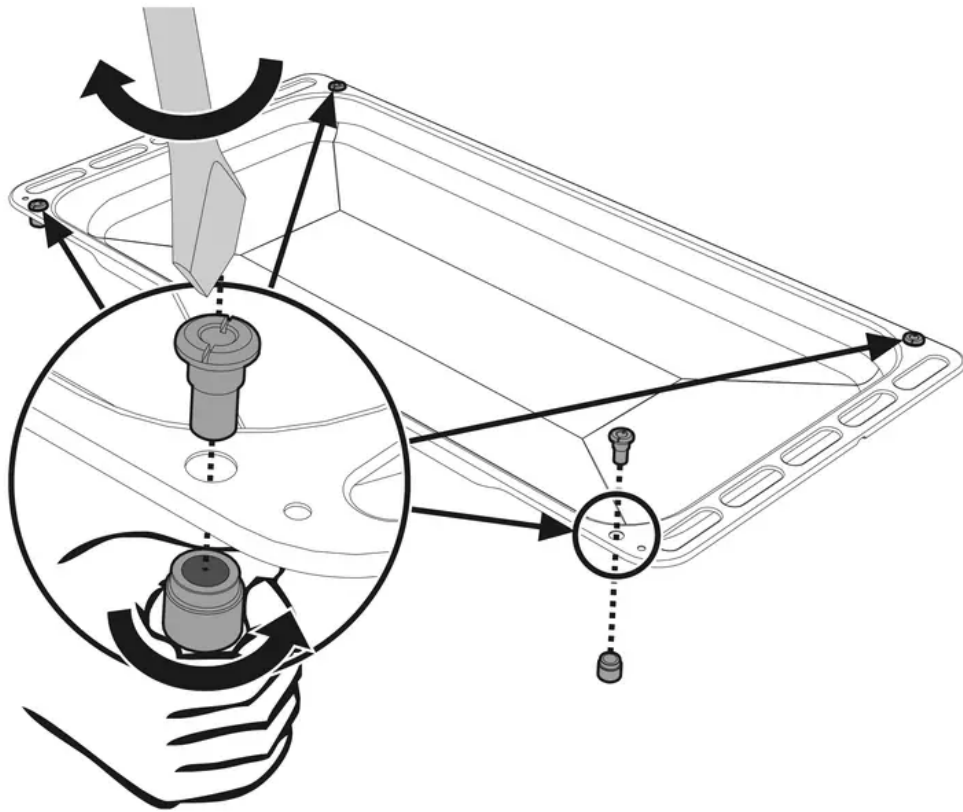

2. Position the rotisserie supports in the bushings as shown in the figure below.

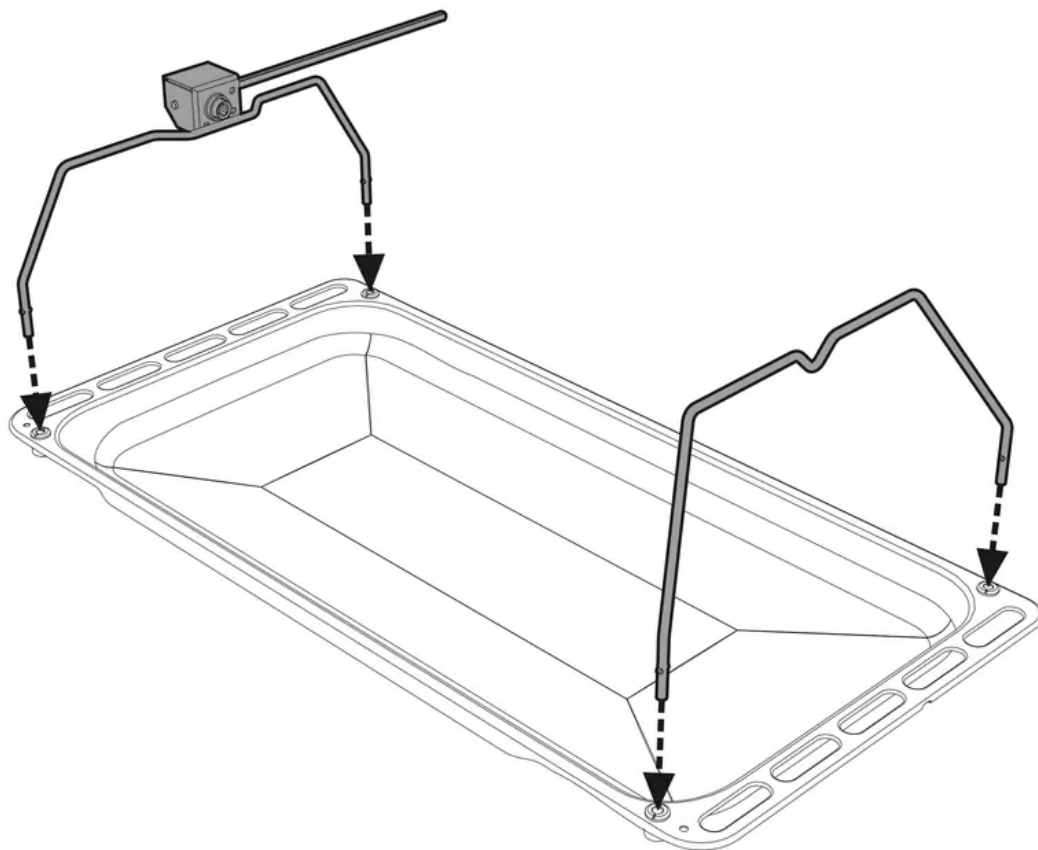

3. Prepare the rotisserie rod with the food using the clip forks provided. The clip forks can be tightened using the fastening screws.

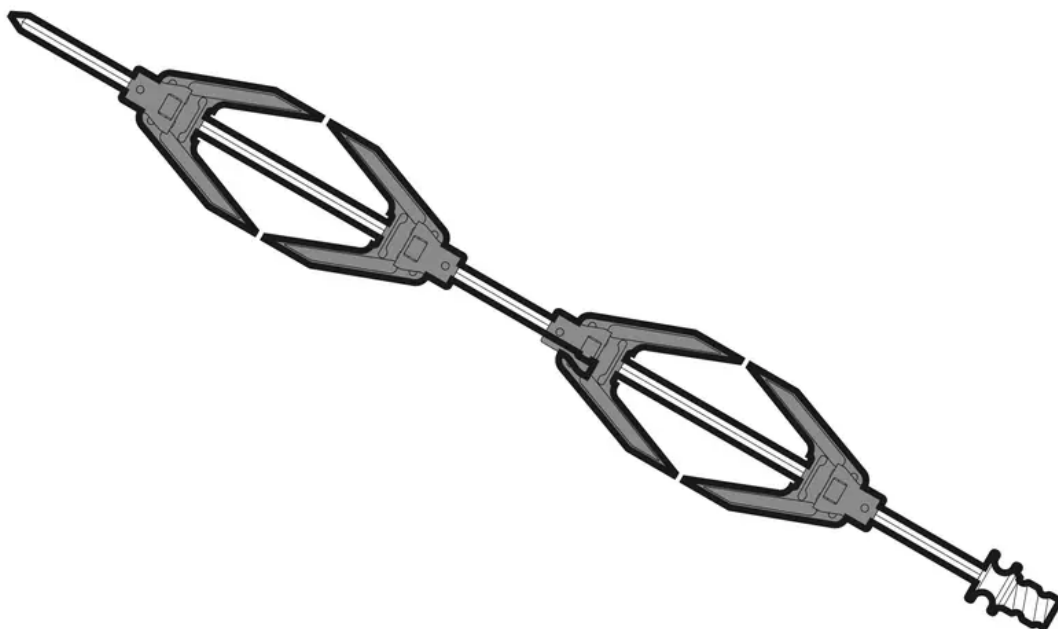

4. Once you have prepared the rotisserie rod, place it on the supports. Insert the tip of the rod in the housing of the mechanism on the left-hand support until it stops.

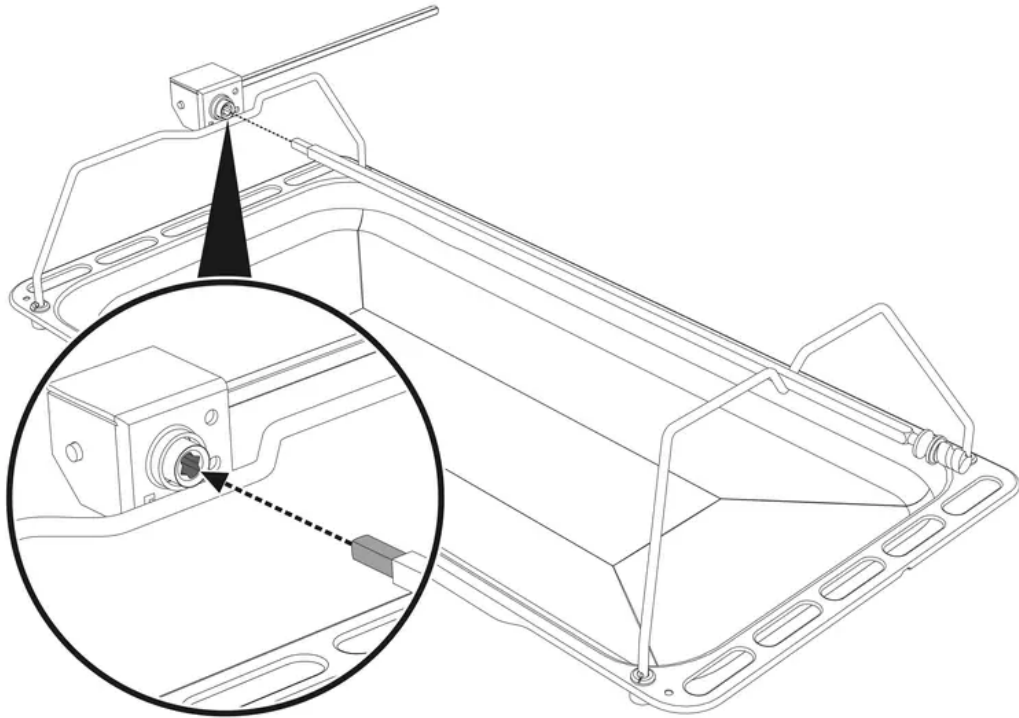

5. Place the tray on the first runner (see "General Description").
6. Insert the tip of the rod in the rotisserie motor housing on the left of the rear wall of the oven.

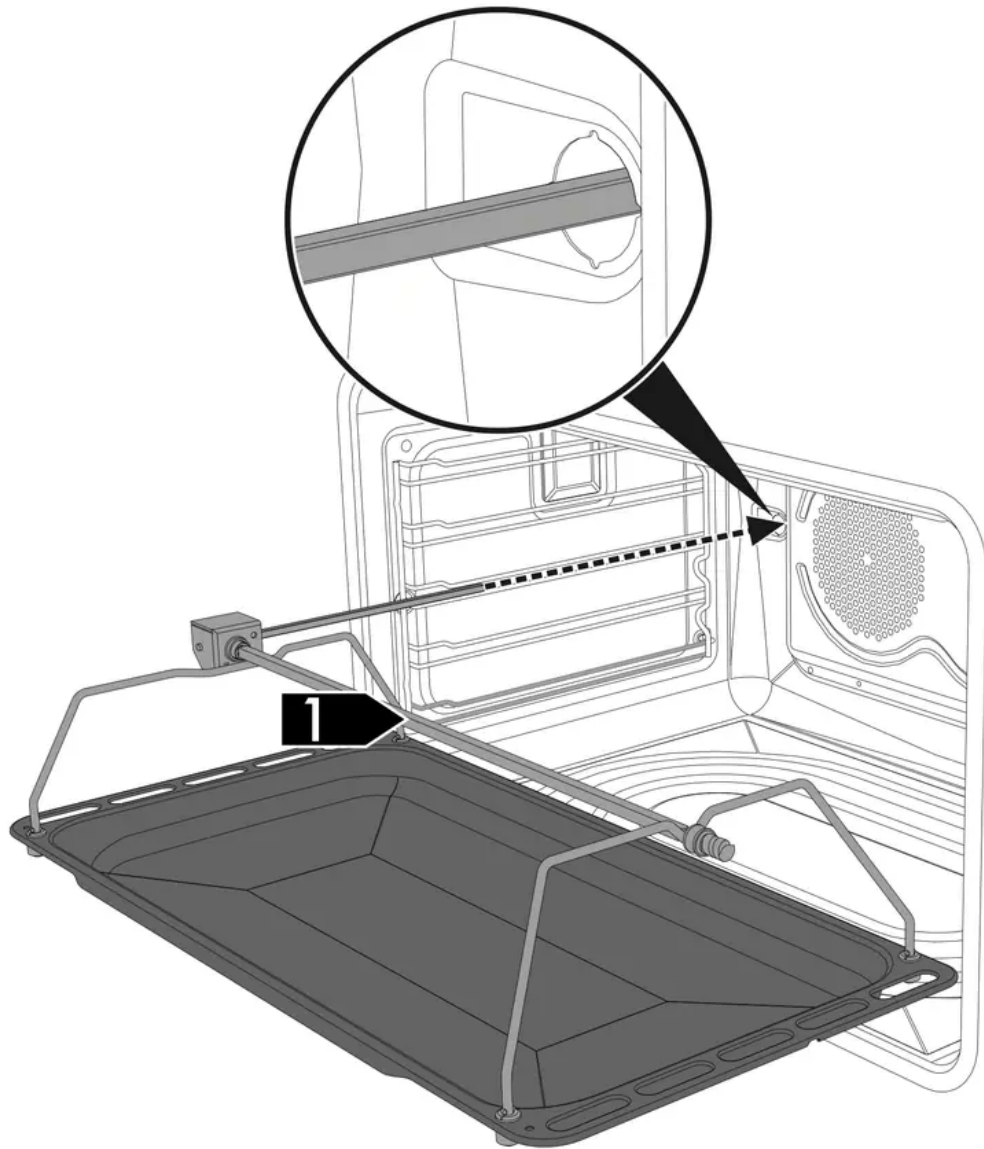

Note: These operations must be performed with the oven off and cold.

7.

To activate the rotisserie, turn the function knob to select the



+



function and use the temperature knob to set a cooking temperature.

Note: Pour a little water into the tray to prevent smoke from forming.

8. When cooking is complete, remove the tray with the rotisserie.

9. Screw on the handle provided so that you can handle the rotisserie rod more easily.

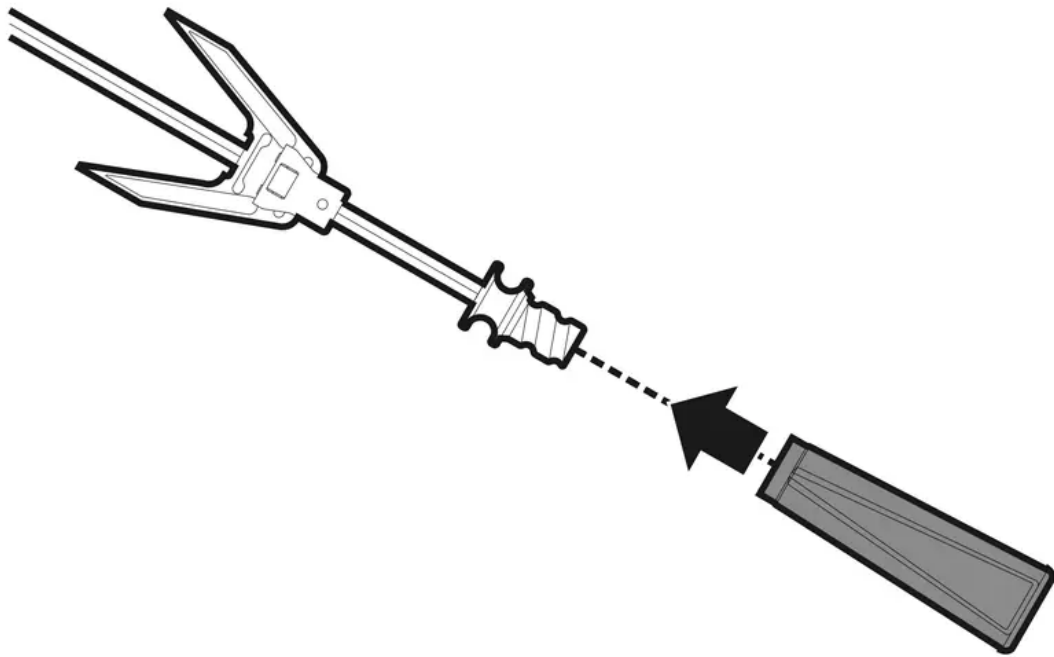

Using the hob

All the appliance's control and monitoring devices are located together on the front panel. The burner controlled by each knob is shown next to the knob. The appliance is equipped with an electronic ignition device. Simply press the knob and turn it anticlockwise to the maximum flame symbol, until the burner ignites. If the burner does not light in the first 15 seconds, turn the knob to



and wait 60 seconds before trying again. After lighting, keep the knob pressed in for a few seconds to allow the thermocouple to heat up.

The burner may go out when the knob is released: In this case, the thermocouple has not heated up sufficiently. Wait a few moments and repeat the operation. Keep the knob pressed in longer.

Note: In case of an accidental switching off, a safety device will be tripped, cutting off the gas



supply, even if the gas cock is open. Return the knob to and wait at least 60 seconds before lighting it again.

Correct positioning of the flamespreader crowns and burner caps

Before lighting the hob burners, make sure that the flame-spreader crowns are correctly positioned in their seats with their respective burner caps. Make sure that the holes **1** of the flame-spreader crowns are aligned with the thermocouples **2** and igniters **3**.

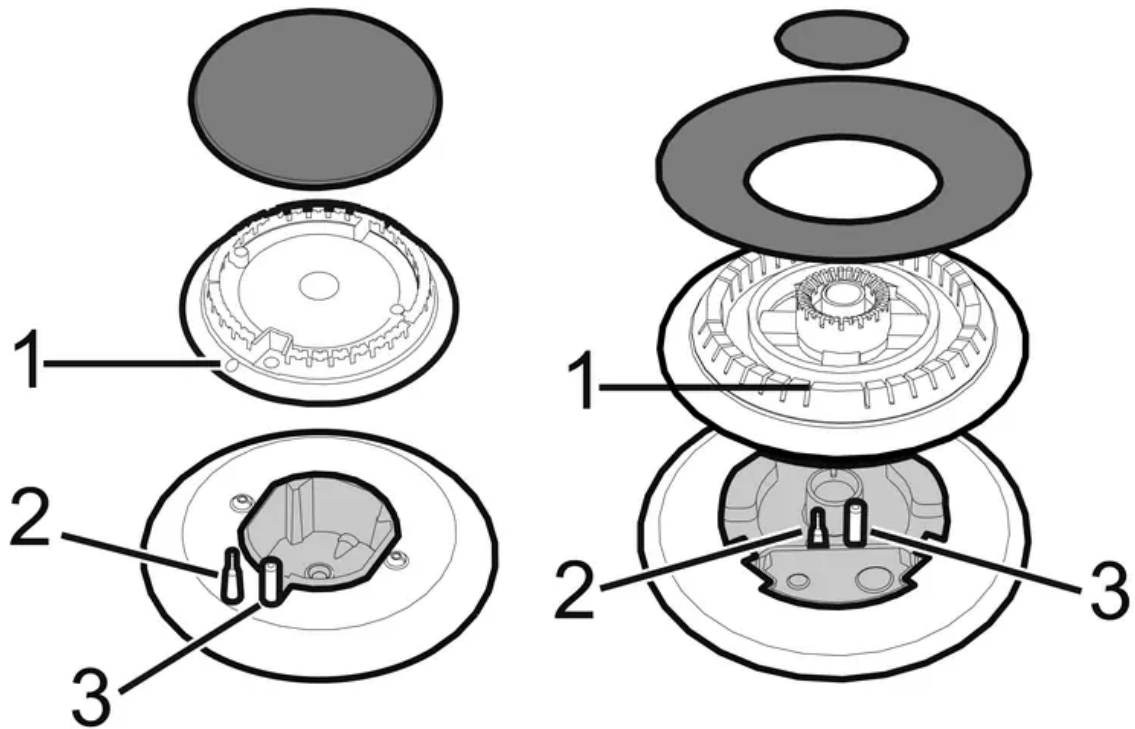

Practical tips for using the hob

For better burner efficiency and to minimise gas consumption, use pans with lids and of suitable size for the burner, so that the flames do not reach up the sides of the pan. Once the contents come to the boil, turn down the flame far enough to ensure that the liquid does not boil over.

Note: Cookware diameters:

- AUX: 12 - 14 cm.
- SR: 16 - 24 cm.
- R: 18 - 26 cm.
- DUAL: 18 - 28 cm.

Correct positioning of the hob grids

Before lighting the hob burners, make sure that the grids are correctly positioned on the hob.

Bear in mind that:

- Each grid has its own position on the hob.

- The raised section must always face the appliance's upstand.

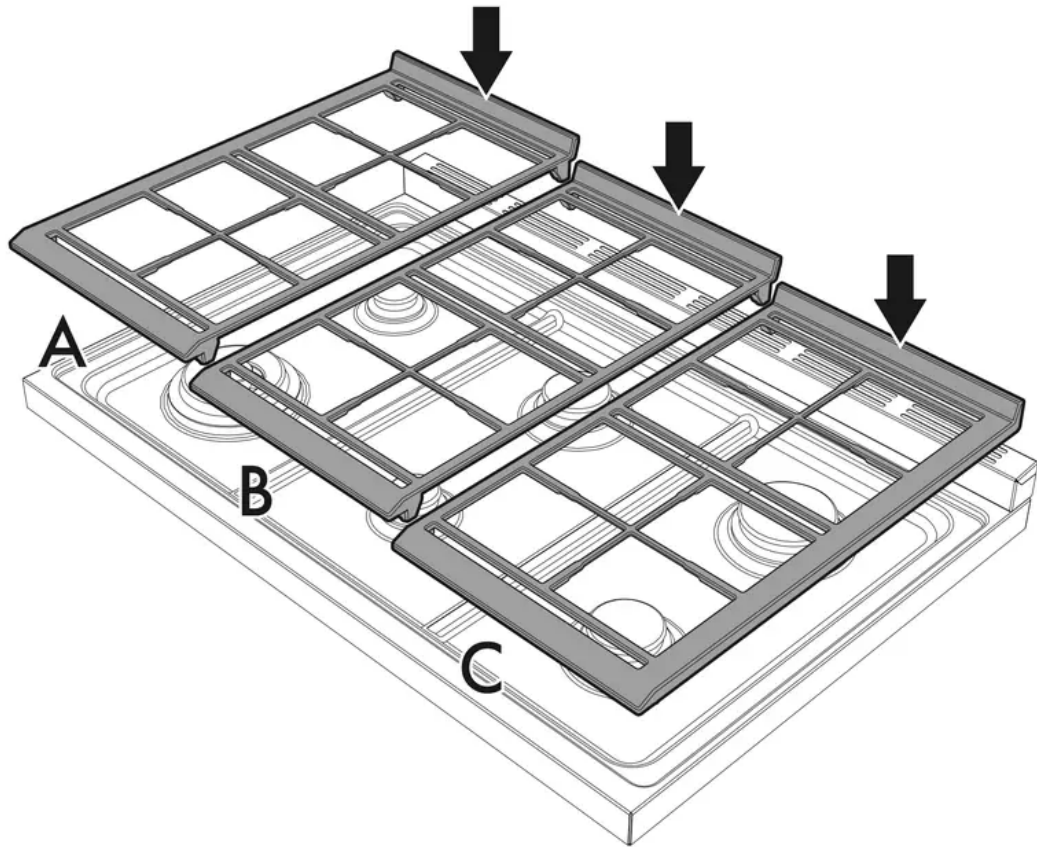

- The left-hand (A) and right-hand (C) grids have one thicker edge which must be turned to face the side of the appliance.
- The edges of the centre grid (B) are of the same thickness.

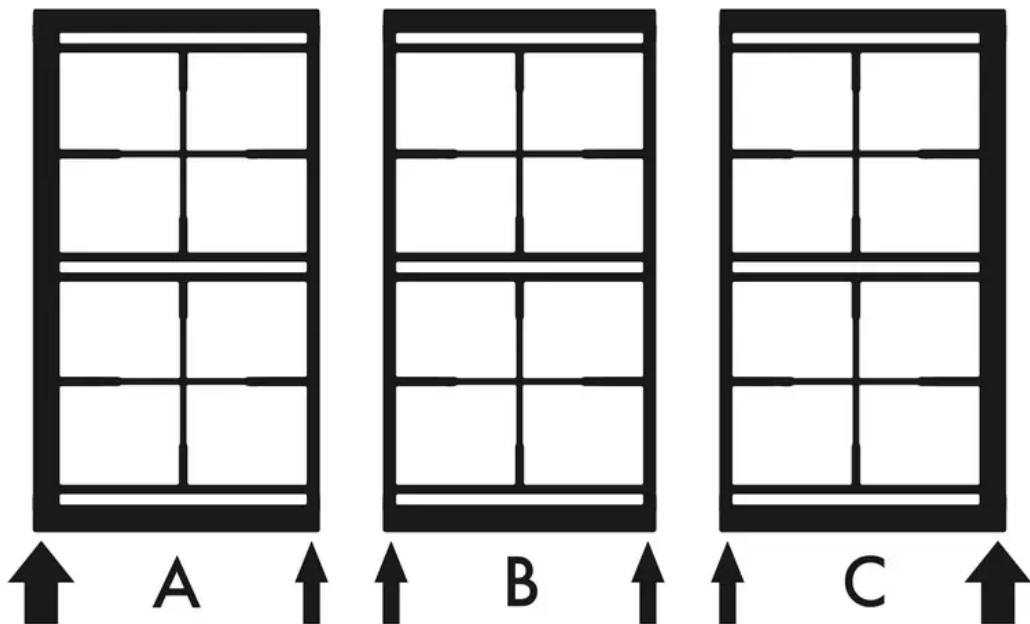

Using the oven

Display

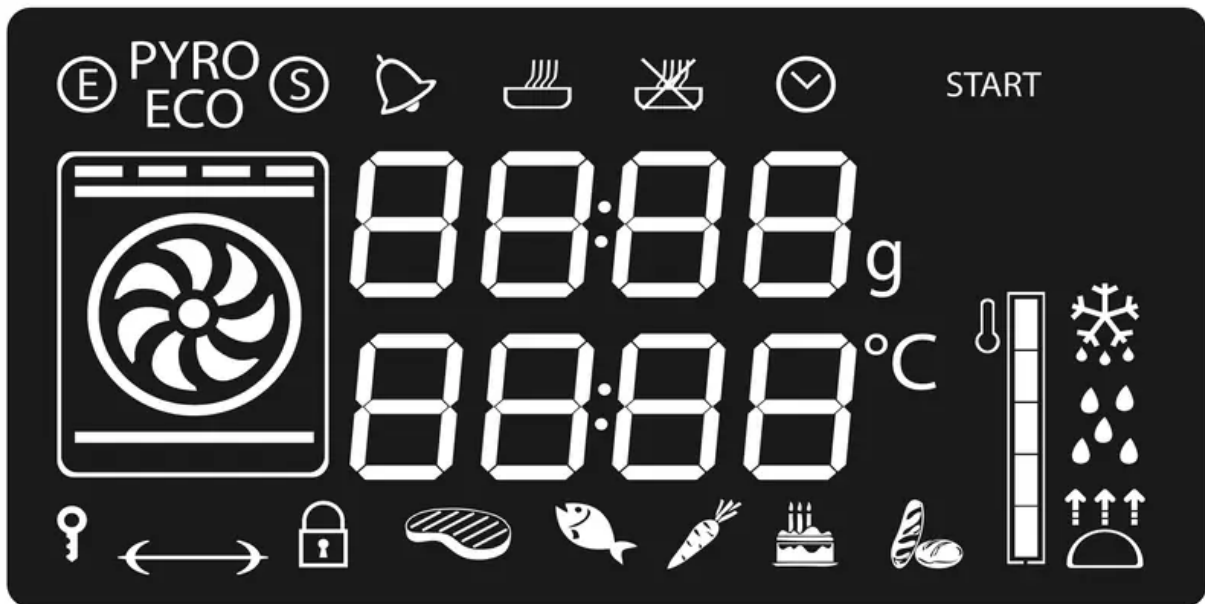

Eco logic indicator light



Pyrolytic function indicator light (pyrolytic models only)



Showroom indicator light



Minute minder timer indicator light



Timed cooking indicator light



Programmed cooking indicator light



Clock indicator light



Child lock indicator light



Rotisserie indicator light (on some models only)



Door lock indicator light (pyrolytic models only)



Temperature level reached

Operating modes

Stand-by: When no function is selected, the display shows the current time.

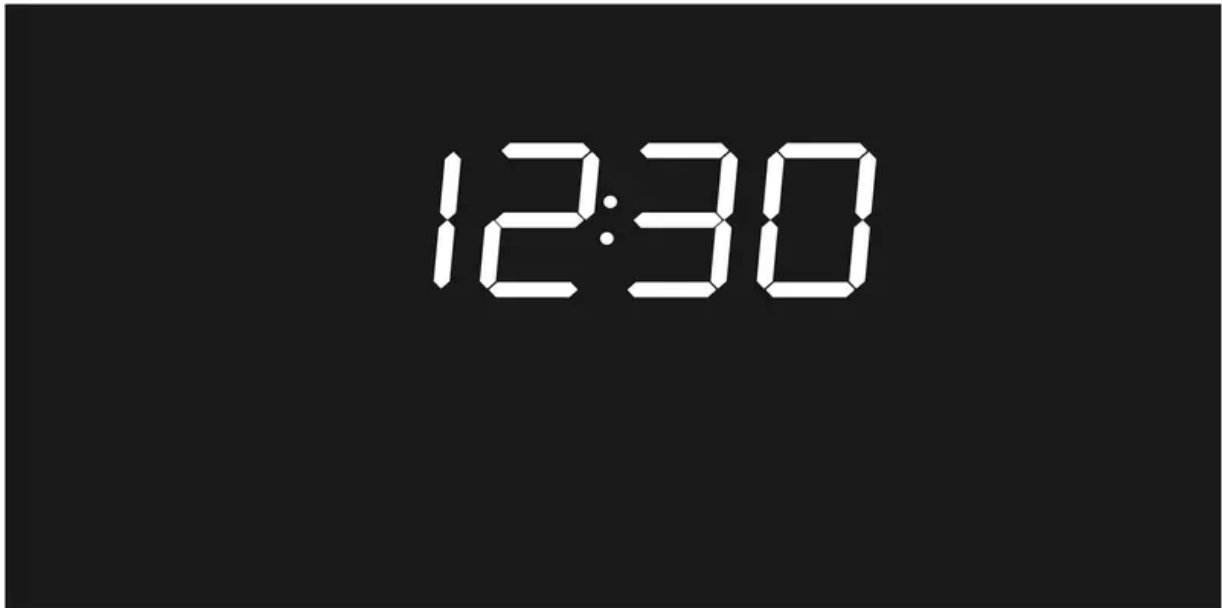

ON: When a function is activated, the display shows the parameters set such as temperature, duration and temperature reached.

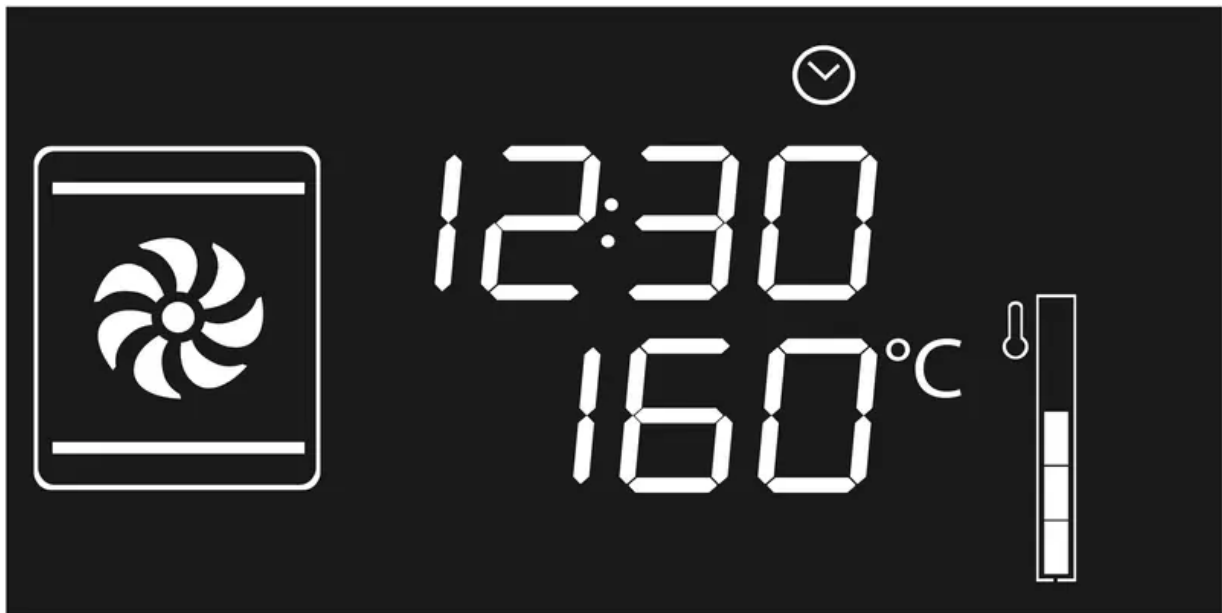

Each time the temperature knob is pressed during a function, the parameters will be cycled through in the following order.



Temperature



Minute minder timer duration



Function duration



Programmed cooking duration (if timed cooking has been selected)



Time display

In all modes it is possible to modify the value by turning the temperature knob to the left or right. Keep the knob turned to produce a faster increase or decrease.

Setting the time

When using the appliance for the first time, or after a power failure, the symbol



will flash on the display. To be able to start any cooking function, the current time must be set.

1. Turn the temperature knob to set the displayed time (keep the knob turned to produce a faster increase or decrease).
2. Press the temperature knob.
3. Turn the temperature knob to set the minutes (keep the knob turned to produce a faster increase or decrease).
4. Press the temperature knob to finish adjustment.

Note: It may become necessary to change the current time, for example for daylight saving time. From the stand-by position, keep the temperature knob turned to the right or left until the hours flash.

It is not possible to change the time if the oven is ON.

Cooking functions

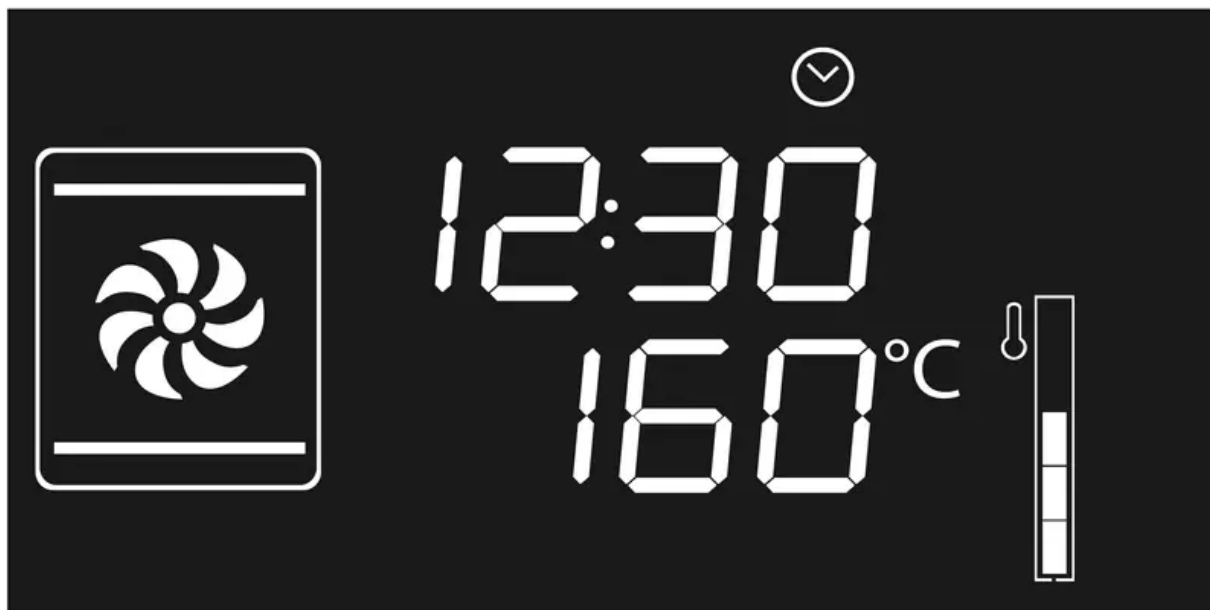

1. Press and turn the function knob to select the required cooking function.
2. Press and turn the temperature knob to modify the cooking temperature.
3. Press the function knob to start traditional cooking.

Note: A function can be interrupted at any time by pressing and holding the function knob for at least 3 seconds.

Preheating stage

Cooking itself is preceded by a preheating stage, which allows the appliance to heat to the cooking temperature more quickly.

The temperature level reached indication flashes to indicate that this stage is in progress.

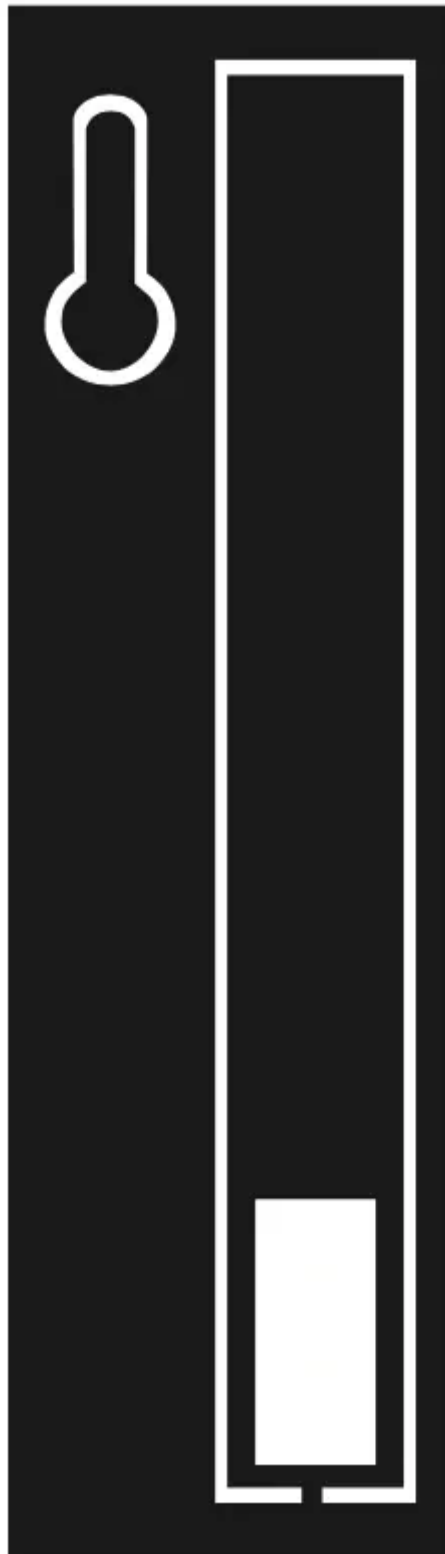

When the preheating stage is complete, temperature level reached indication will remain lit steadily and a buzzer sounds to indicate that the food can be placed inside the oven.



Functions list

Eco

This function is particularly suitable for cooking on a single shelf with low energy consumption.

Ideal for cooking meat, fish and vegetables. It is not recommended for leavened foods.

To obtain maximum energy savings and reduce cooking times, it is recommended to place food in the oven without preheating.

Note: When using the ECO function, avoid opening the door during cooking.

Important: Cooking (and preheating) times are longer with the ECO function.

Static

As the heat comes from above and below at the same time, this system is particularly suitable for certain types of food. Traditional cooking, also known as static cooking, is suitable for cooking just one dish at a time. Perfect for all types of roasts, bread and cakes, and in any case, particularly suitable for fatty meats such as goose and duck.

Grill

The heat coming from the grill element gives perfect grilling results above all for thin and medium thickness meat and, in combination with the rotisserie (where fitted), gives the food an even browning at the end of cooking. Perfect for sausages, spare ribs and bacon. This function enables large quantities of food, particularly meat, to be grilled evenly.

Lower element

The heat coming just from the bottom allows you to complete the cooking of foods that require a higher bottom temperature, without affecting their browning. Perfect for cakes, pies, tarts and pizzas.

Fan assisted

The operation of the fan, combined with traditional cooking, ensures consistent cooking even with complex recipes. Perfect for biscuits and cakes, even when simultaneously cooked on several levels. (For multiple-level cooking, we recommend using the 2nd and 4th shelf).

Fan with grill

The air produced by the fan softens the strong heatwave generated by the grill, grilling perfectly even very thick foods. Perfect for large cuts of meat (e.g. shin of pork).

Fan + lower element

The combination of the fan with just the lower heating element allows cooking to be completed more rapidly. This system is recommended for sterilising or for finishing off the cooking of foods which are already well-cooked on the surface, but not inside, which therefore need a little more heat. Perfect for any type of food.

Circulaire

The combination of the fan and the circulaire heating element (incorporated in the rear of the oven) allows you to cook different foods on several levels, as long as they need the same temperature and type of cooking. Hot air circulation ensures instant and even distribution of

heat. It will be possible, for instance, to cook fish, vegetables and biscuits simultaneously (on different levels) without odours and flavours mingling.

Turbo



The combination of fan assisted cooking and traditional cooking allows different foods to be cooked on several levels extremely quickly and efficiently, without odours and flavours mingling. Perfect for large volumes that call for intense cooking.

Timer

Important: This function only activates the buzzer, without stopping cooking.

Important: The minute minder can be activated both during cooking and when the appliance is in standby.

1. Press the temperature knob once (twice if cooking is already in progress). The display

shows  and the indicator light  flashes.

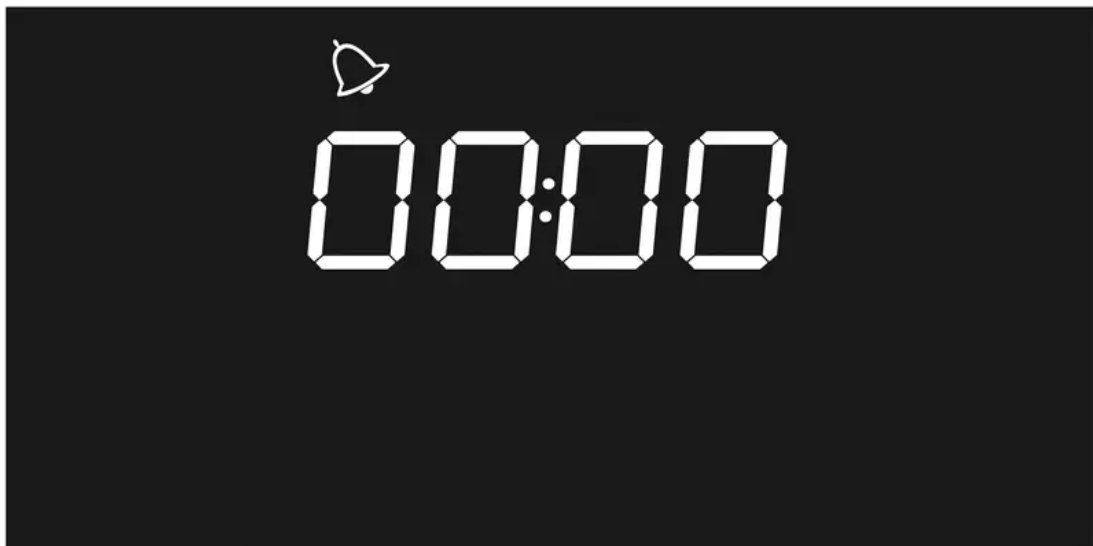

2. Turn the temperature knob to set the duration (from 1 minute to 4 hours). After a few

seconds, the indicator light  stops flashing and the countdown starts.

3. Select the required cooking function and wait for the buzzer to sound, indicating that the

cooking time is over. The indicator light  flashes.

4. To deactivate the buzzer, press or turn one of the two knobs.

5. To select a further minute minder, turn the temperature knob.

Note: You must set the value to zero to remove the minute minder.

Timed cooking

Important: Timed cooking is the function which allows a cooking operation to be started and then ended after a specific length of time set by the user.

Important: Activation of timed cooking cancels any minute minder timer which may previously have been set.

1. After selecting a cooking function and temperature, press the temperature knob three

times. The display shows  and the indicator light  flashes.

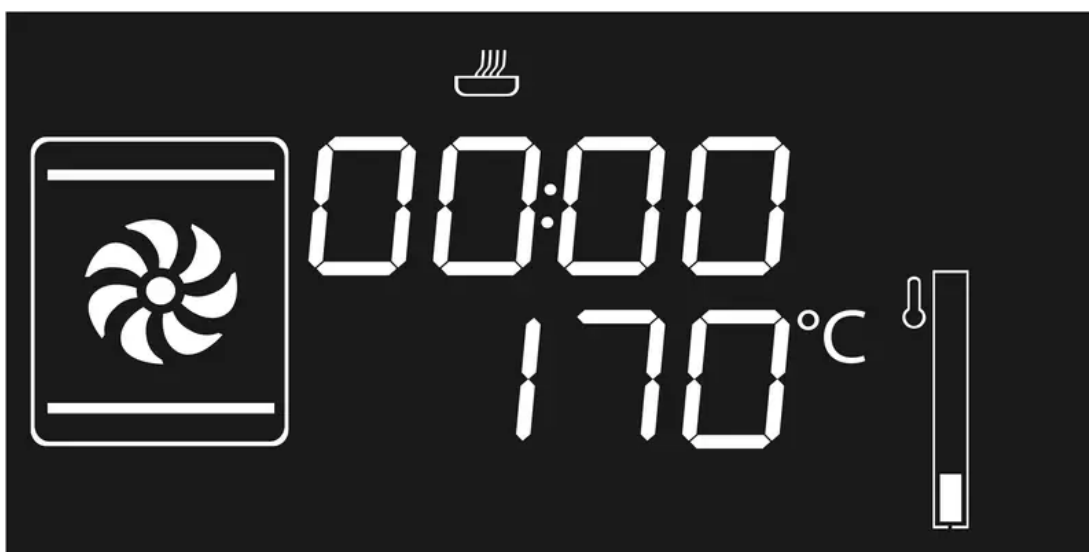

2. Turn the temperature knob right or left to set the cooking duration from 00:01 to 12:59. Keep the knob turned to produce a faster increase or decrease.

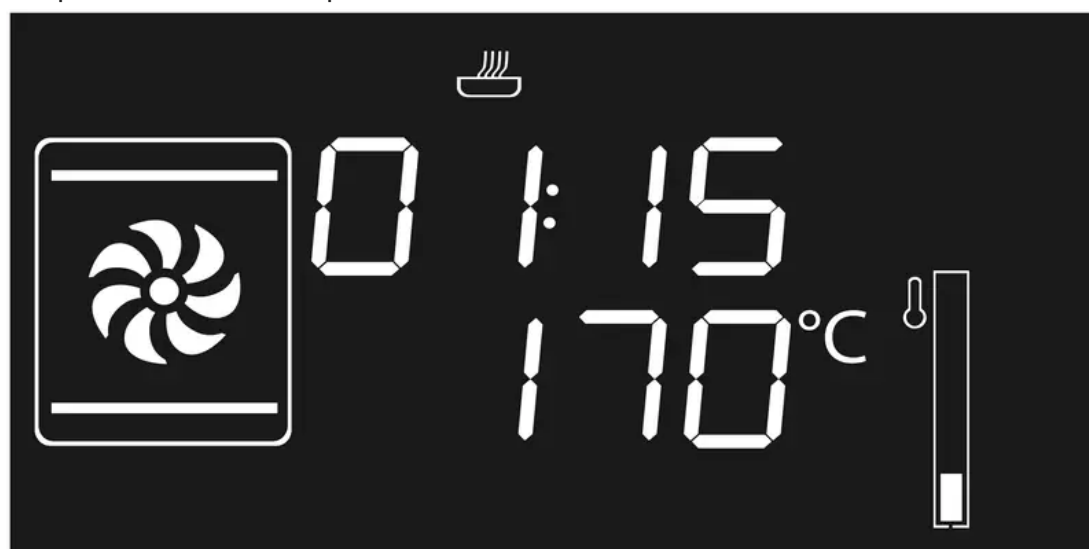

- 3.

A few seconds after the required duration is set, the indicator light  stops flashing and timed cooking starts.

Note: To extend the cooking time manually, press the temperature knob again. The appliance will resume its normal operation with the previously selected cooking settings.

4.

At the end of cooking,  is shown on the display and a buzzer sounds.



5. To deactivate the buzzer, press or turn one of the two knobs or open the door.

Note: To deactivate the buzzer and select a further timed cooking, turn the temperature knob to the right.

Note: To deactivate the buzzer and select a different cooking function, turn the function knob to the right or left.

Note: Press and hold the function knob down to switch off the appliance.

Modifying the data set during timed cooking

During operation, it is possible to modify timed cooking duration:

1.

When the indicator light  is steady and cooking is in progress inside the

appliance, press the temperature knob twice. The indicator light  starts flashing.

2. Turn the temperature knob right or left to alter the pre-set cooking time.

Programmed cooking

Important: Programmed cooking is the function which allows cooking to be stopped at an established time depending on the time set by the user, after which the appliance will switch off automatically.

1. After selecting a cooking function and temperature, press the temperature knob three

times. The display shows  and the indicator light  flashes.

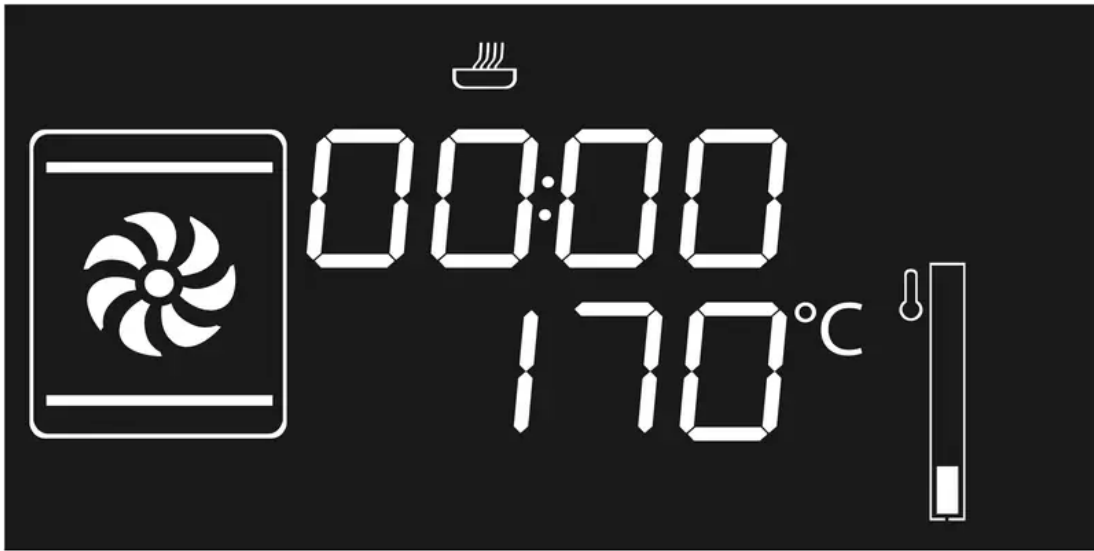

2. Turn the knob right or left to set the cooking duration from 00:01 to 12:59. Keep the knob turned for a fast increase or decrease.

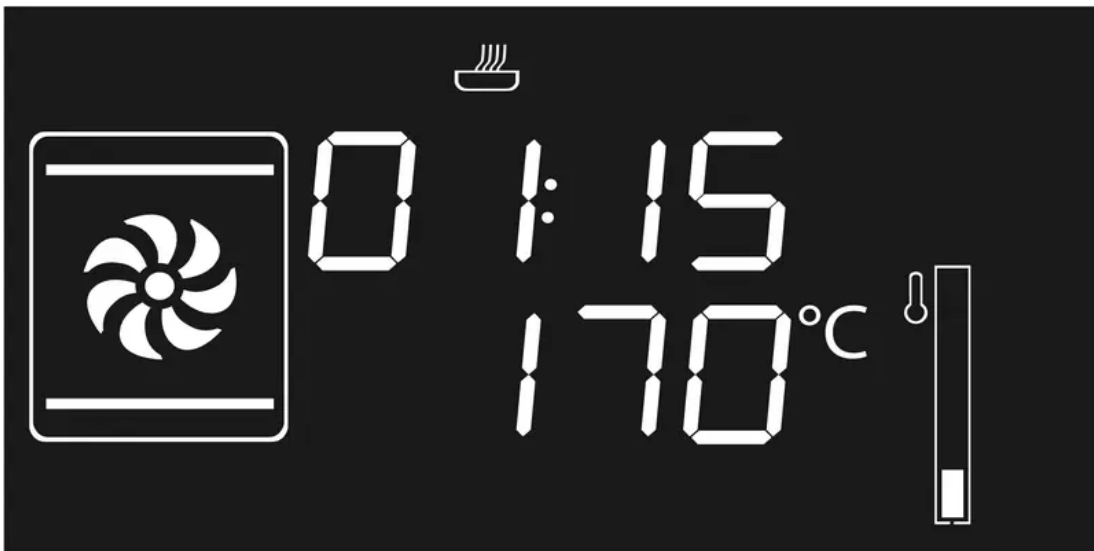

- 3.

Press the temperature knob a fourth time. The indicator light  flashes. Turn the knob right or left to set the cooking end time.

4.



After a few seconds the indicator lights and stop flashing. The appliance waits for the set start time.

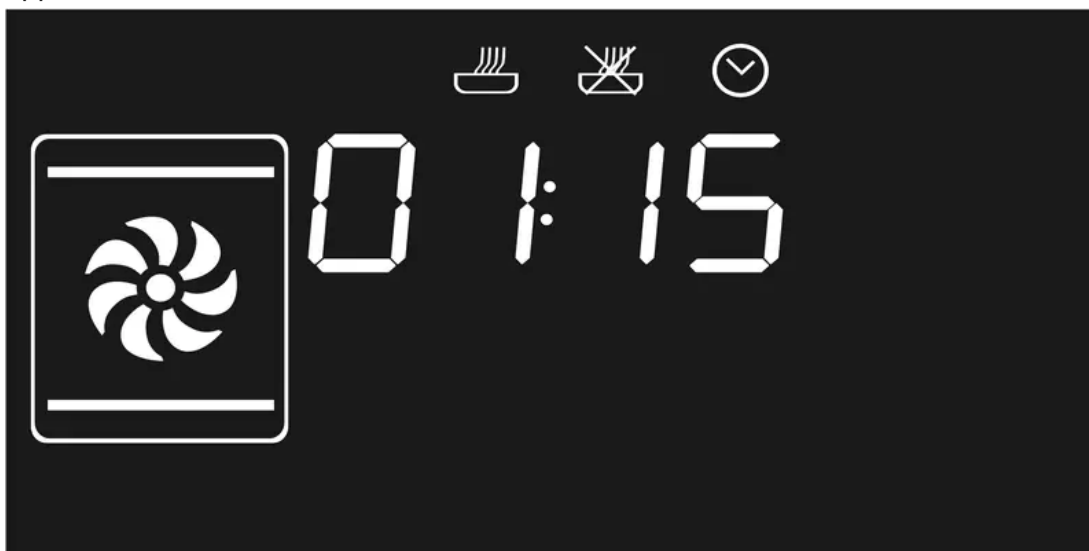

Note: To extend the cooking time manually, press the temperature knob again. The appliance will resume its normal operation with the previously selected cooking settings.

Important: With timed cooking, the oven is switched on ten minutes beforehand to allow the appliance to reach cooking temperature (preheating).

5.



At the end of cooking, **STOP** is shown on the display and a buzzer sounds.



6. To deactivate the buzzer, press or turn one of the two knobs or open the door.

Note: Press and hold the function knob down to switch off the appliance.

Important: For safety reasons, it is not possible to set the end of cooking time by itself without setting the cooking duration.

Modifying the data set during programmed cooking

Note: After modifying the cooking duration, the end of cooking time must be re-set.

During operation, it is possible to modify programmed cooking duration:

1.

When the indicator lights  and  are lit steadily and the appliance is

waiting for cooking to start, press the temperature knob twice. The indicator light  starts flashing.

2. Turn the temperature knob right or left to alter the pre-set cooking time.



3.

Press the temperature knob again. The indicator light  switches off and the

indicator light  starts flashing. The display shows the cooking end time.

4. Turn the temperature knob right or left to delay the cooking end time.

5.

After a few seconds the indicator lights  and  stop flashing and programmed cooking resumes its operation with the new settings.

Cooking advice

General advice

- Use a fan assisted function to achieve consistent cooking at several levels.
- It is not possible to shorten cooking times by increasing the temperature (the food could be overcooked on the outside and undercooked on the inside).
- The weight being equal, the cooking time for cut pieces is lower than the cooking time for whole pieces.

Advice for cooking meat

- Cooking times vary according to the thickness and quality of the food and to consumer taste.
- Use a meat thermometer when roasting meat, or simply press on the roast with a spoon. If it is hard, it is ready; If not, it needs another few minutes cooking.

Advice for cooking with the Grill

- Meat can be grilled even when it is put into the cold oven or into the preheated oven if you wish to change the effect of the cooking.

- With the Fan with grill function, we recommend that you preheat the oven before grilling.
- We recommend placing the food at the centre of the rack.

Advice for cooking desserts/pastries and biscuits

- Use dark metal moulds: They help to absorb the heat better.
- The temperature and the cooking time depend on the quality and consistency of the dough.
- In the case of multiple-level cooking, position the food preferably on the 2nd and 4th shelves, increase the cooking time by a few minutes and use only fanassisted functions.
- To check whether the dessert is cooked right through: At the end of the cooking time, put a toothpick into the highest point of the dessert. If the dough does not stick to the toothpick, the dessert is cooked.
- If the dessert collapses when it comes out of the oven, on the next occasion reduce the set temperature by about 10°C, selecting a longer cooking time if necessary.
- The cooking times for meringues and profiteroles vary according to size.

Advice for defrosting and proving

- Place frozen foods without their packaging in a lidless container on the first shelf of the oven.
- Avoid overlapping the food.
- To defrost meat, use the rack placed on the second level and a tray on the first level. In this way, the liquid from the defrosting food drains away from the food.
- Fruit and bread, if divided into pieces, take the same time to thaw, irrespective of the quantity and the total weight.
- The most delicate parts can be covered with aluminium foil.
- For successful proving, a container of water should be placed in the bottom of the oven.

To save energy

- Stop cooking a few minutes before the time normally used. Cooking will continue for the remaining minutes with the heat which has accumulated inside the oven.
- Reduce any opening of the door to a minimum to avoid heat dispersal.
- Keep the inside of the appliance clean at all times.
- (Where fitted) When it is not being used, remove the pizza plate from the bottom of the oven.

Special functions

Defrost by time

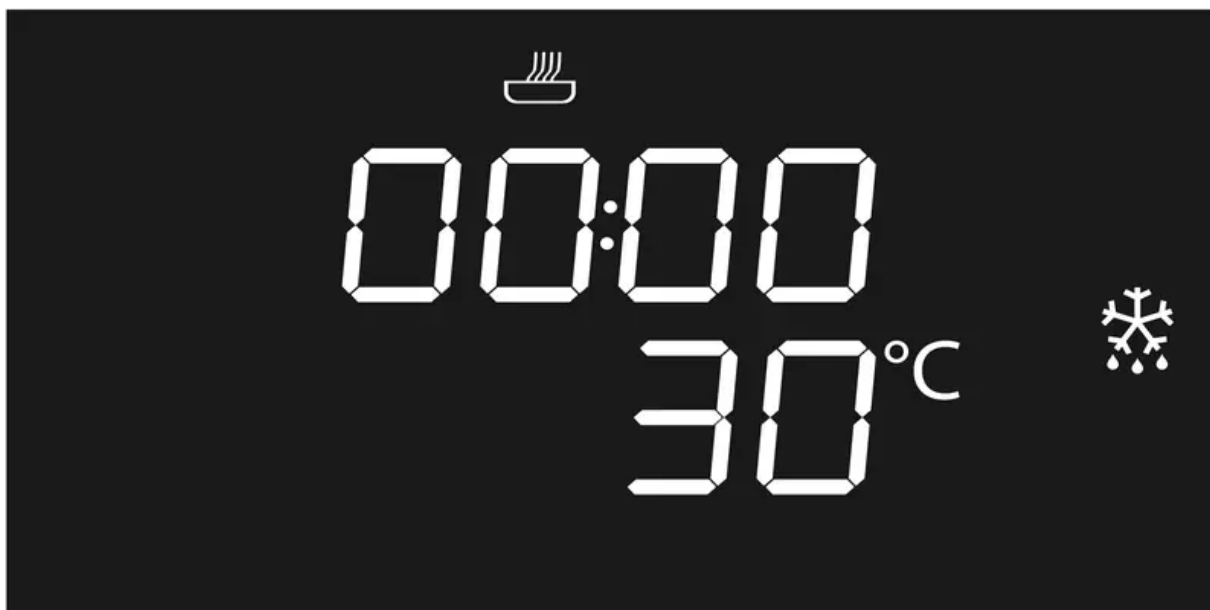

1. Place the food inside the oven.

2.



Press and turn the function knob to select the defrost by time function .

3. Turn the temperature knob to set the duration (from 1 to 99 minutes).

4.



Press the temperature knob to confirm the set duration. flashes.

5. Press the function knob to start the defrost by time function.

6.



At the end, is displayed and a buzzer sounds.

7. To deactivate the buzzer, press or turn one of the two knobs or open the door.

8. Press and hold the function knob for at least 3 seconds to exit the function.

Proving

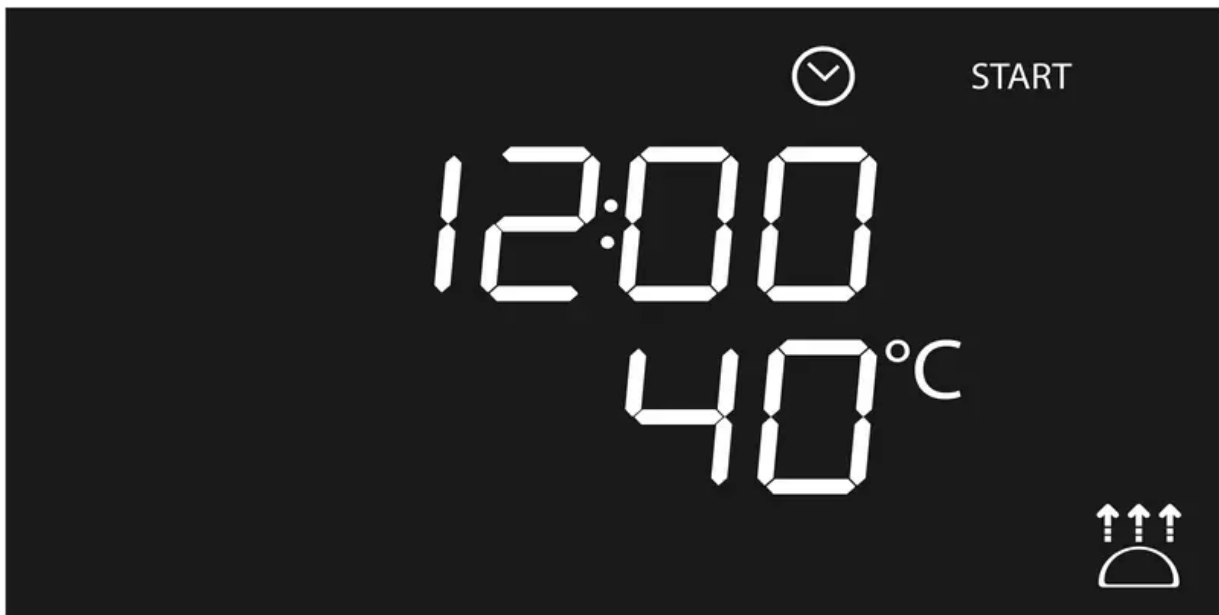

Note: When using the proving function the temperature cannot be altered.

Important: For successful proving, a container of water should be placed in the bottom of the oven.

1. Position the dough for proving on the second shelf.
- 2.

Press and turn the function knob to select the proving function



START flashes.

3. Press the function knob to start the proving function.
- 4.

At the end, **STOP** is displayed and a buzzer sounds.

5. To deactivate the buzzer, press or turn one of the two knobs or open the door.
6. Press and hold the function knob for at least 3 seconds to exit the function.

Sabbath



Important: This function allows food to be cooked in accordance with the provisions of the Jewish religion day of rest.

Note: This function results in the appliance operating in a particular way:

- Cooking can proceed indefinitely, it is not possible to set any time.
- No preheating will be performed.
- The cooking temperature which can be selected varies between 60-100 °C.
- Oven light disabled, any operation such as opening the door or manual activation with the knob will not activate the light.
- The internal fan remains turned off.
- Knob illumination and audible prompts remain disabled.

Note: After activating the Sabbath function the settings cannot be altered.

Any action on the knobs will produce no effect; only the function knob remains active to allow the appliance to be turned off.

1.

Press and turn the function knob to select the Sabbath function



2. Press and turn the temperature knob to modify the temperature of the function.

3.

Press the temperature knob to confirm the set temperature. flashes.



4. Press the function knob to start the Sabbath function.

5. Press and hold the function knob for at least 3 seconds to exit the function.

Defrost by weight



Important: This function defrosts foods on the basis of the type and weight of the frozen products.

1. Place the food inside the oven.
2. Press and turn the function knob to select defrost by weight, marked by



and the illuminated food symbols



3. Press the function knob to confirm the defrost by weight function.
4. Turn the function knob to select the type of food to defrost.
5. Turn the temperature knob to select the weight (in grams) of the food to defrost.
6. Press the function knob to confirm the parameters and start defrosting.





7.



At the end, **STOP** is displayed and a buzzer sounds.

8. To deactivate the buzzer, press or turn one of the two knobs or open the door.
9. Press and hold the function knob for at least 3 seconds to exit the function.

Pre-set parameters

dE	Type	Weight (g)	Time (min)*
01	 Meat	500	120
02	 Fish	300	55
03	 Fruit	300	35
04	 Bread	300	25

* Defrosting times may vary on the basis of the shape and size of the food to be defrosted.

Automatic programs

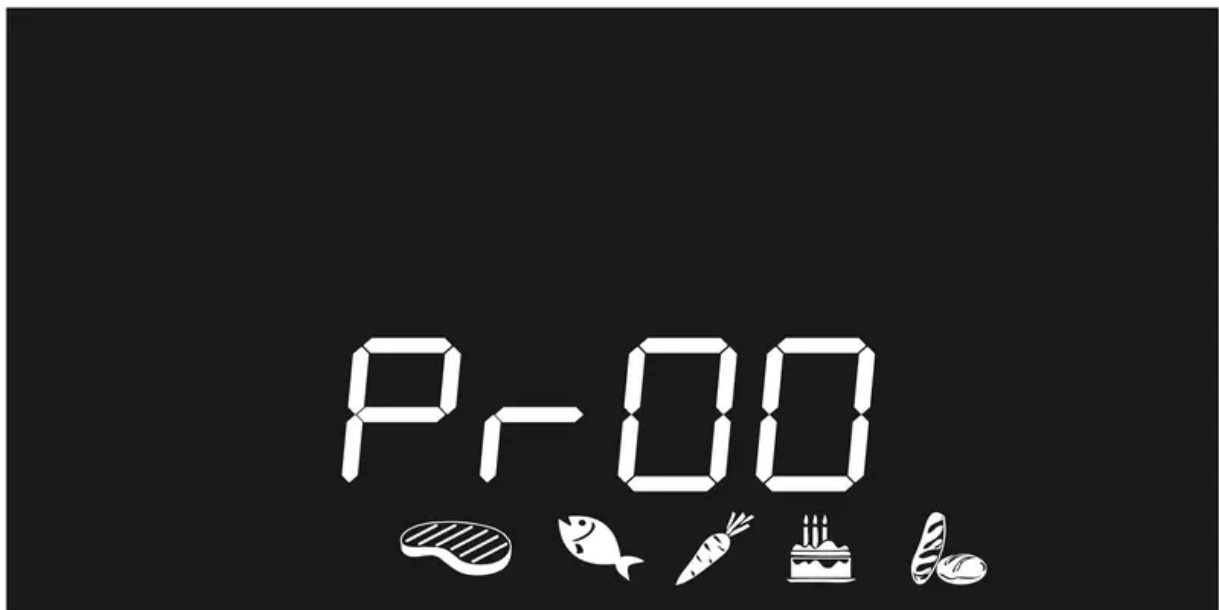

The automatic cooking programs are divided up according to the type of dish to be cooked.

1. Press and turn the function knob to select cooking with automatic programs, marked by



and the illuminated food symbols



2. Press the function knob to confirm cooking with automatic programs.
3. Turn the function knob to select the preferred program (see Automatic programs table).
4. Turn the temperature knob to select the weight (in grams) of the food to cook.
- 5.



When preheating has finished, **START** will flash. Introduce the food and then press the function knob to start cooking.

- 6.



At the end, **STOP** is displayed and a buzzer sounds.

7. To deactivate the buzzer, press or turn one of the two knobs or open the door.
8. Press and hold the function knob for at least 3 seconds to exit the function.





Note: It is possible to set programmed cooking in automatic programs.

Note: A function can be interrupted at any time by pressing and holding the function knob for at least 3 seconds.

Automatic programs table



MEAT (01 - 05)

Pr	Subcategory	Weight (g)	Level	Function	Temperature (°C)	Time (minutes)
01	Roast beef (cooked medium)	1300	2		200	56
02	Roast pork	800	2		190	88
03	Lamb (cooked medium)	2000	2		190	105
04	Veal	1000	2		190	80
05	Roast chicken (whole)	1000	2		200	80



FISH (06 - 07)

Pr	Subcategory	Weight (g)	Level	Function	Temperature (°C)	Time (minutes)
06	Fresh fish (whole)	500	2		160	35
07	Frozen fish	600	2		160	50



VEGETABLES (08 - 10)

Pr	Subcategory	Weight (g)	Level	Function	Temperature (°C)	Time (minutes)
08	Mixed grilled	500	4		250	15 + 8 ⁽¹⁾
09	Roast	1000	2		200	33
10	Roasted potatoes	1000	2		200	30

(1) For grilling, cooking food on both sides and referring to the times indicated in the table is recommended. The greater cooking time indicated always refers to the first side to be cooked starting from the raw food.









DESSERTS/PASTRIES (11 - 13)

Pr	Subcategory	Weight (g)	Level	Function	Temperature (°C)	Time (minutes)
11	Biscuits	500	2		160	23
12	Muffins	500	2		160	21
13	Tart	1000	2		170	43



BREAD - PIZZA - PASTA (14 - 20)

Pr	Subcategory	Weight (g)	Level	Function	Temperature (°C)	Time (minutes)
14	Leavened bread (loaf)	1000	2		200	27
15	Pan baked pizza	1000	2		280	12
16	Stone baked pizza	500	1*		280	7
17	Pasta bake	2000	1		220	35
18	Lasagne	2000	1		230	40
19	Paella	500	2		190	25
20	Quiche	1000	1		200	40

(2) The stone must be placed at the bottom of the oven. The frozen pizza cooked on the stone does not require different cooking times depending on weight.

Note: The times indicated in the tables do not include preheating times and refer to cooking whole pieces. If the food is cut into smaller portions, the cooking time decreases.

Secondary menu

The appliance also has a drop-down secondary menu allowing the user to:

- Activate or deactivate the Child lock.
- Activate or deactivate Showroom mode (which disables all the heating elements so that only the control panel works).
- Activate or deactivate Eco-Logic mode.
- Activate or deactivate Keep Warm mode.

- Activate or deactivate Eco-light mode.

With the appliance in Stand-By

1. Activate the internal light by turning the temperature knob quickly.
2. Press and hold the temperature knob down for at least 5 seconds.
3. Turn the temperature knob right or left to change the setting status (ON/OFF).
4. Press the temperature knob to move to the next mode.

Child lock mode

This mode allows the appliance to lock the controls automatically after one minute of normal operation without any intervention from the user.

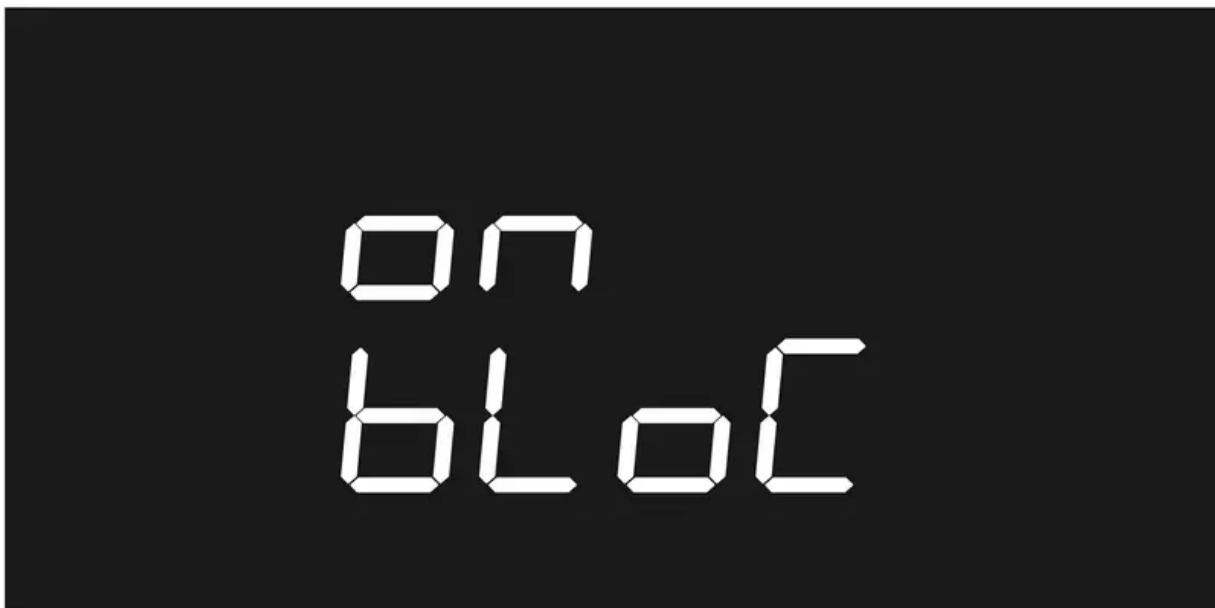
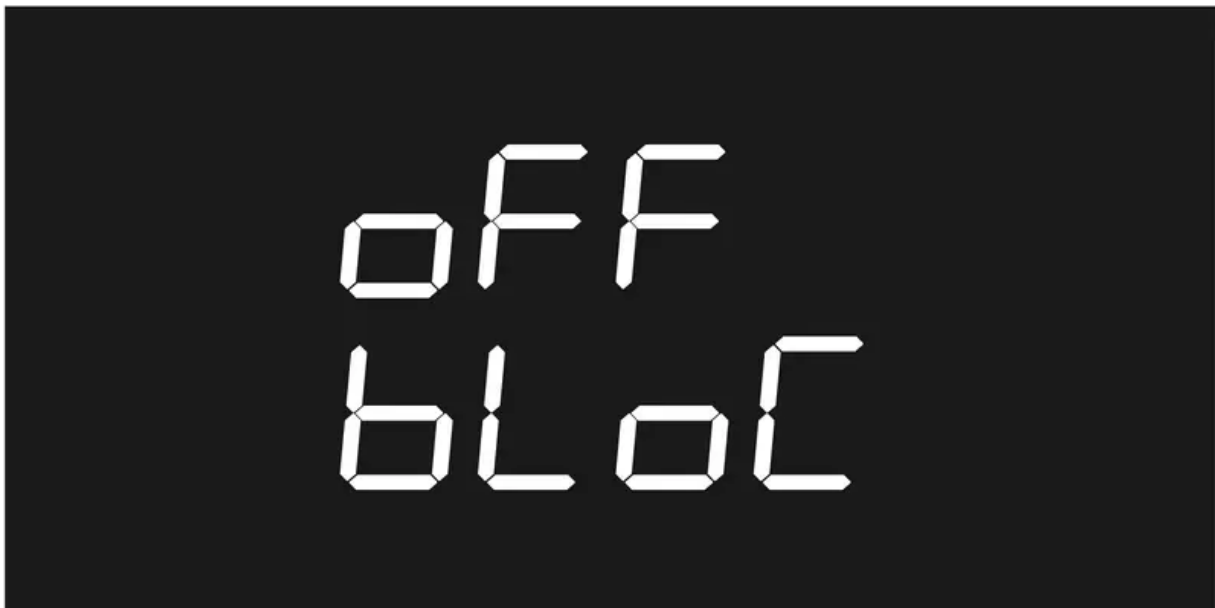



During normal operation it is indicated by the indicator light coming on.

To release the lock temporarily during cooking, hold the temperature knob down for 5 seconds. One minute after the last setting the lock will become active again.



Note: When the position of the knobs is changed, the display will show for a few seconds.

Note: It is still possible to turn the appliance off instantaneously by pressing and holding the function knob down for 3 seconds when in child lock mode.

Showroom mode (for exhibitors only)

This mode allows the appliance to deactivate all heating elements, while keeping the control panel active.



To use the appliance normally, set this mode to OFF.



Important: If the mode is active, the indicator light  lights up on the display.

Low power (Eco-logic) mode:

This mode allows the appliance to limit the power used.

Suitable for simultaneous use with further home appliances.

HI: normal power.

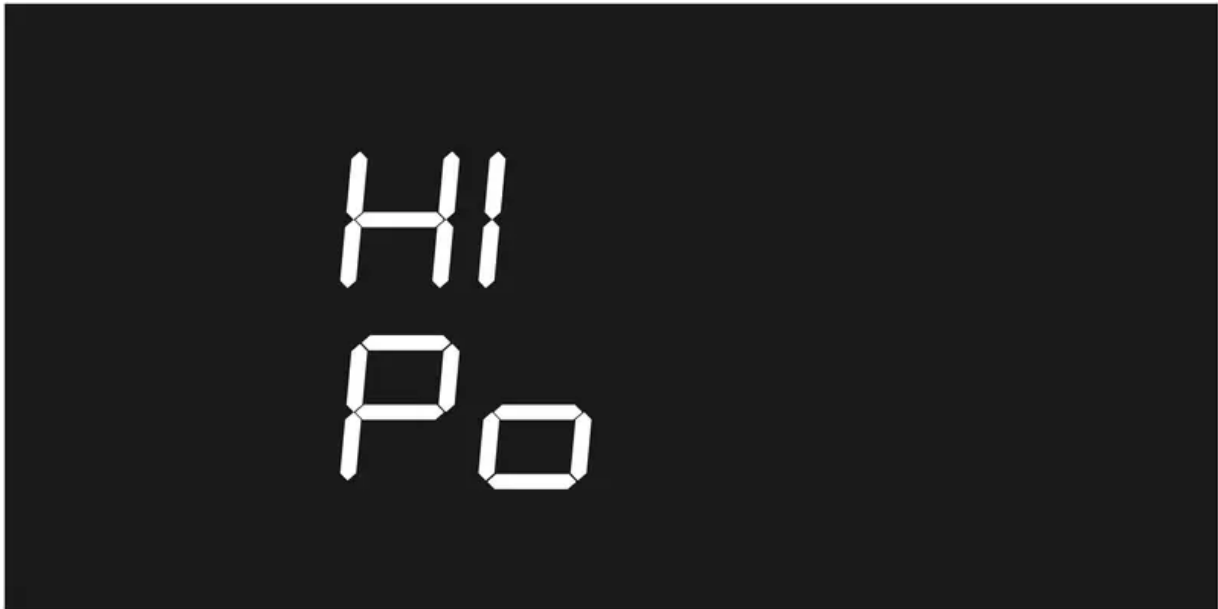

LO: low power.



Note: Activating eco-logic mode means that preheating and cooking times may be extended.



Important: If the mode is active, the indicator light  lights up on the display.

Keep Warm mode

This mode allows the appliance to keep cooked food warm (at low temperatures) for around an hour after cooking finishes with a cooking cycle for which a duration has been set (if this is not manually interrupted).





Eco-light mode

For greater energy savings, the light is automatically deactivated one minute from the start of cooking.



To stop the appliance from automatically deactivating the light after one minute, set this mode to OFF.



Note: The manual off/on control is always available with both settings by turning the temperature knob to the right.

Using the storage compartment

There is a storage compartment located at the bottom of the cooker; this can be used to store pans or metal objects required for its use.

1. To open the storage compartment, press lightly on the left-hand side of the door until it clicks.

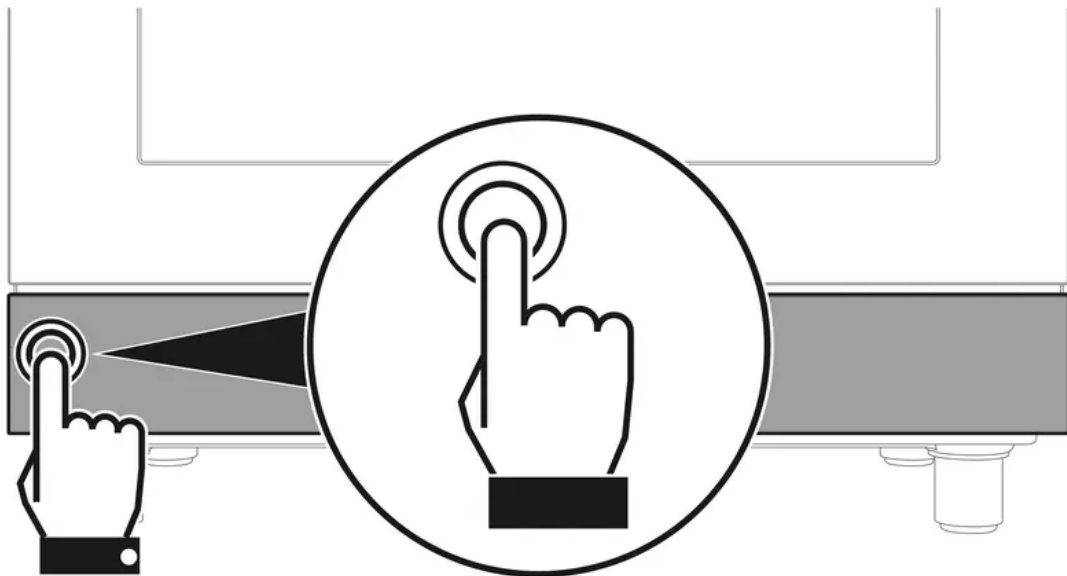

2. Gently release the storage compartment door.

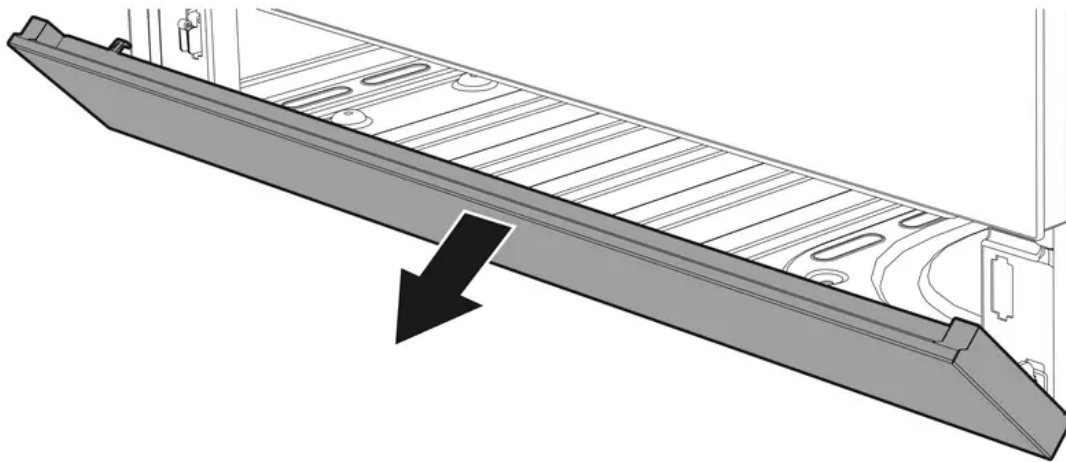

3. To close the storage compartment again, lift the door until it clicks.

Cleaning and maintenance

Instructions

Caution: Improper use - Risk of damage to surfaces

- Do not use steam jets to clean the appliance.
- Do not use cleaning products containing chlorine, ammonia or bleach on parts made of steel or that have metallic surface finishes (e.g. anodizing, nickel or chromium-plating).
- Do not use abrasive or corrosive detergents (e.g. scouring powders, stain removers and metallic sponges) on glass parts.
- Do not use rough or abrasive materials or sharp metal scrapers.
- Do not wash the removable components such as the hob grids, flame-spreader crowns and burner caps in a dishwasher.

Cleaning the appliance

Note: We recommend the use of cleaning products distributed by the manufacturer.

Recommendations for cleaning the hob

To keep the surfaces in good condition, they should be cleaned regularly after use. Let them cool first.

Cleaning the hob

1. Pour some non-abrasive detergent on a damp cloth and wipe the surfaces.
2. Rinse thoroughly.
3. Dry with a soft cloth or a microfibre cloth.

Cleaning the hob grids, flame-spreader crowns and burner caps

1. Remove the components from the hob.
2. Clean with lukewarm water and nonabrasive detergent. Make sure to remove any encrustations.
3. Dry thoroughly with a soft cloth or a microfibre cloth.
4. Replace the components on the hob.

Important: The continuous contact between the grids and the flame can cause modifications to the enamel over time in those parts exposed to heat. This is a completely natural phenomenon which has no effect on the operation of this component.

Cleaning the igniters and thermocouples

- If necessary, clean the igniters and thermocouples with a damp cloth.
- If there is any dry residue, remove it with a toothpick or needle.

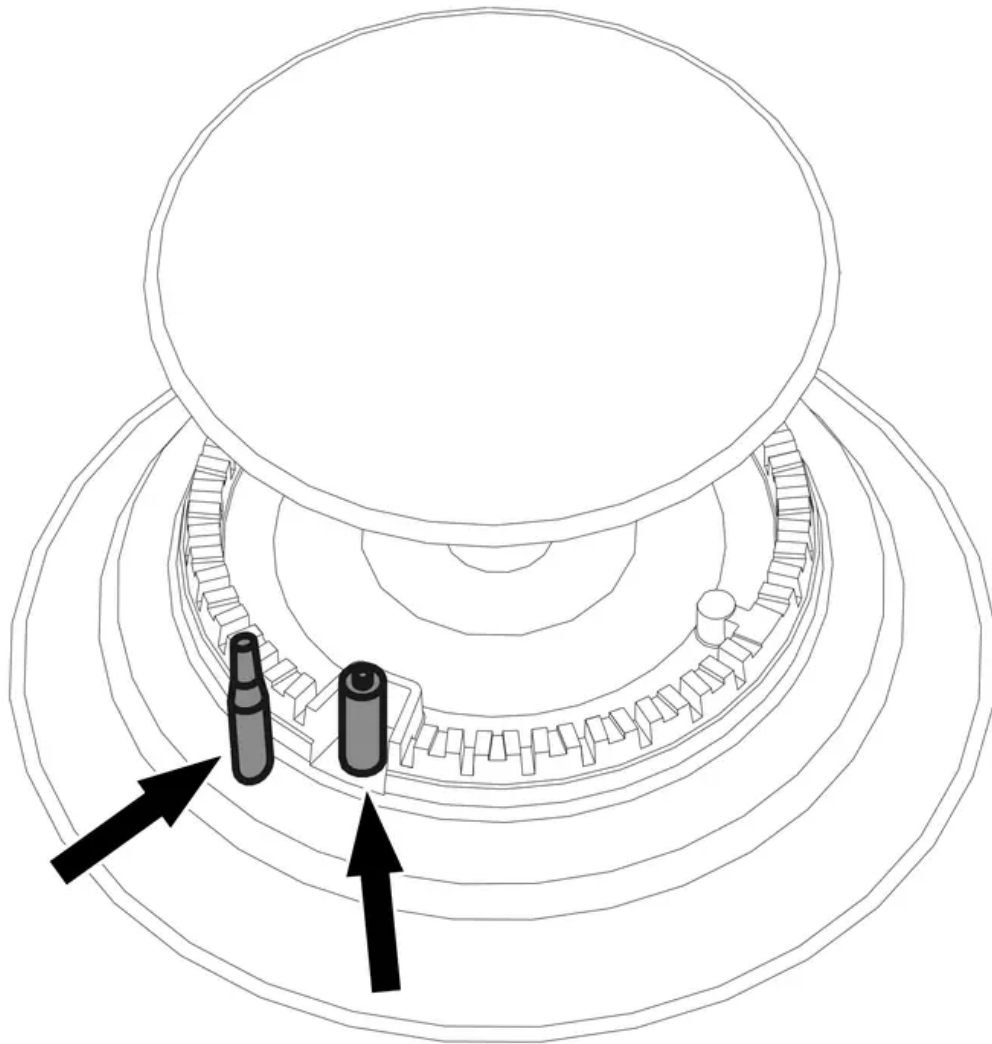

Cleaning the oven cavity

In order to keep your oven in the best possible condition, clean it regularly after letting it cool down.

Avoid letting food residue dry inside the oven cavity, as this could damage the enamel.

Take out all removable parts before cleaning.

For easier cleaning, we recommend removing:

- The door
- The rack/tray support frames
- Removable guides, where fitted
- The seal

Note: In the event you are using specific cleaning products, we recommend running the oven at maximum temperature for 15-20 minutes in order to eliminate any residue.

Removing the door

For easier cleaning it is recommended to remove the door and place it on a tea towel.

To remove the door proceed as follows:

1. Open the door completely and insert two pins into the holes on the hinges indicated in the figure.

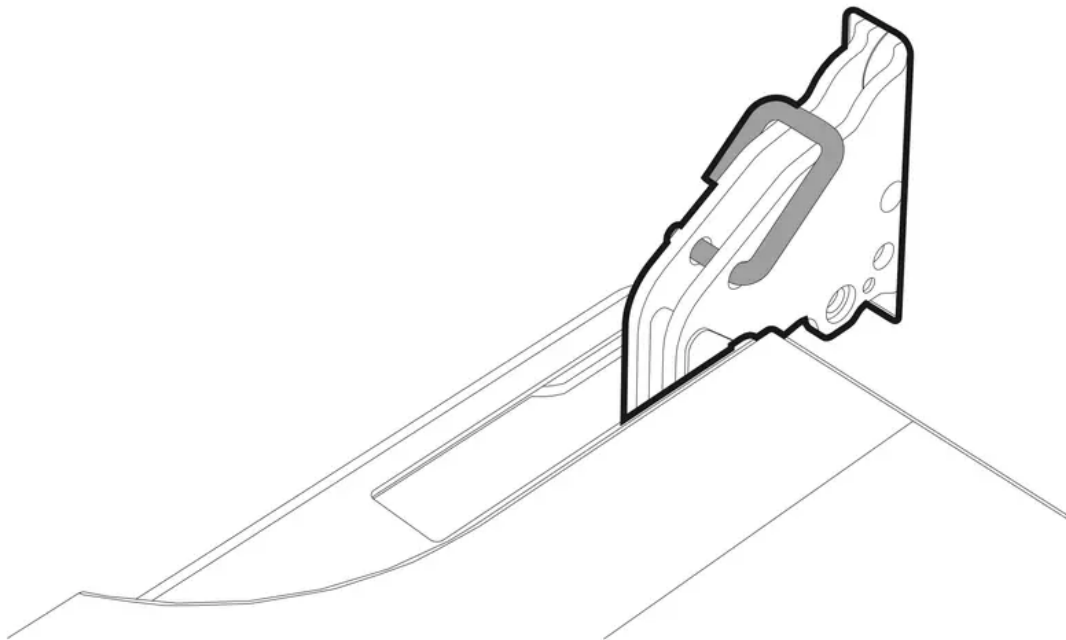

2. Grasp the door on both sides with both hands, lift it forming an angle of around 30° and remove it.

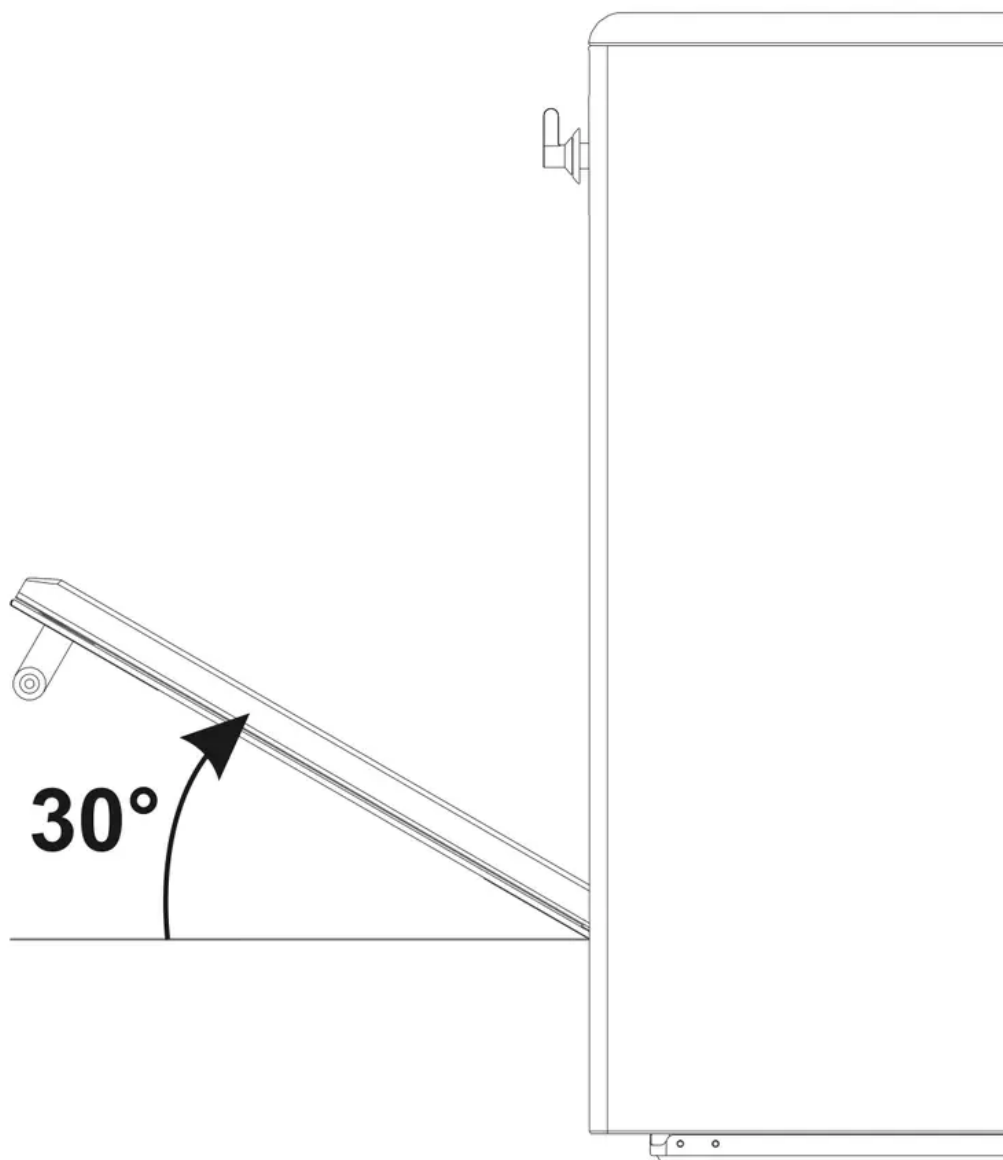

3. To reassemble the door, put the hinges in the relevant slots in the oven, making sure that grooved sections **A** are resting completely in the slots. Lower the door and once it is in

place remove the pins from the holes in the hinges.

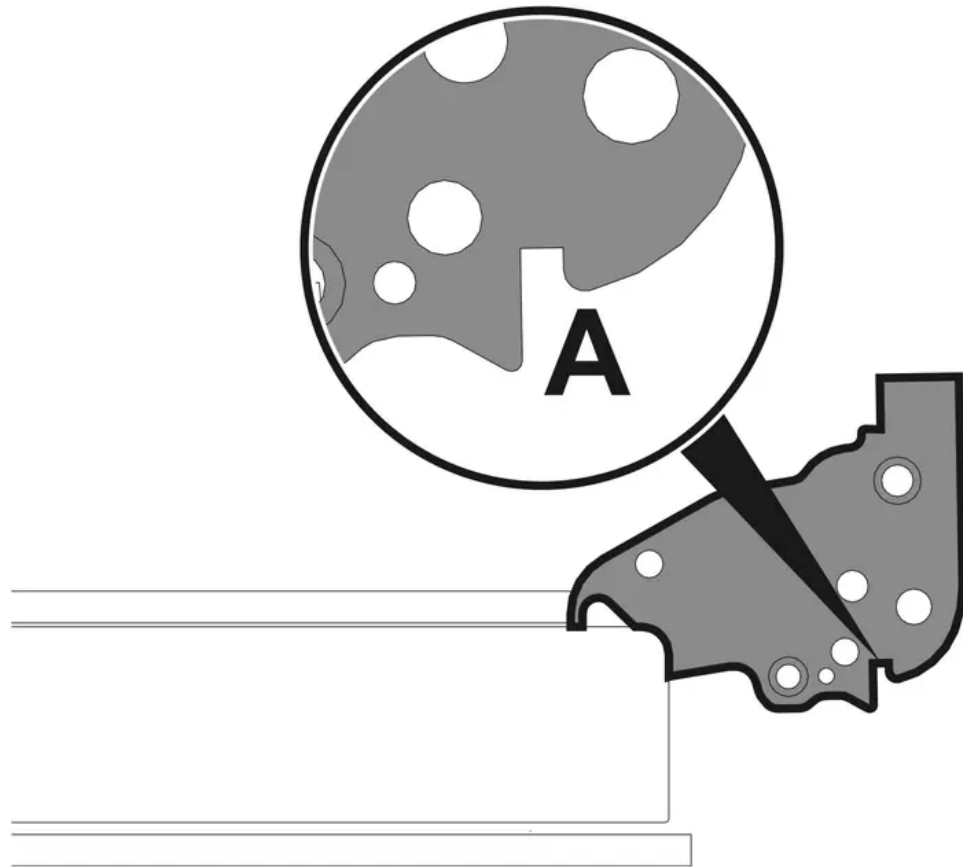

Cleaning the door glazing

The glass in the door should always be kept thoroughly clean. Use absorbent kitchen roll. In case of stubborn dirt, wash with a damp sponge and an ordinary detergent.

Removing the internal glass panes

For easier cleaning the internal glass panes of the door can be removed.

1. Pull the rear part of the internal glass pane gently upwards, following the movement indicated by the arrows (1).

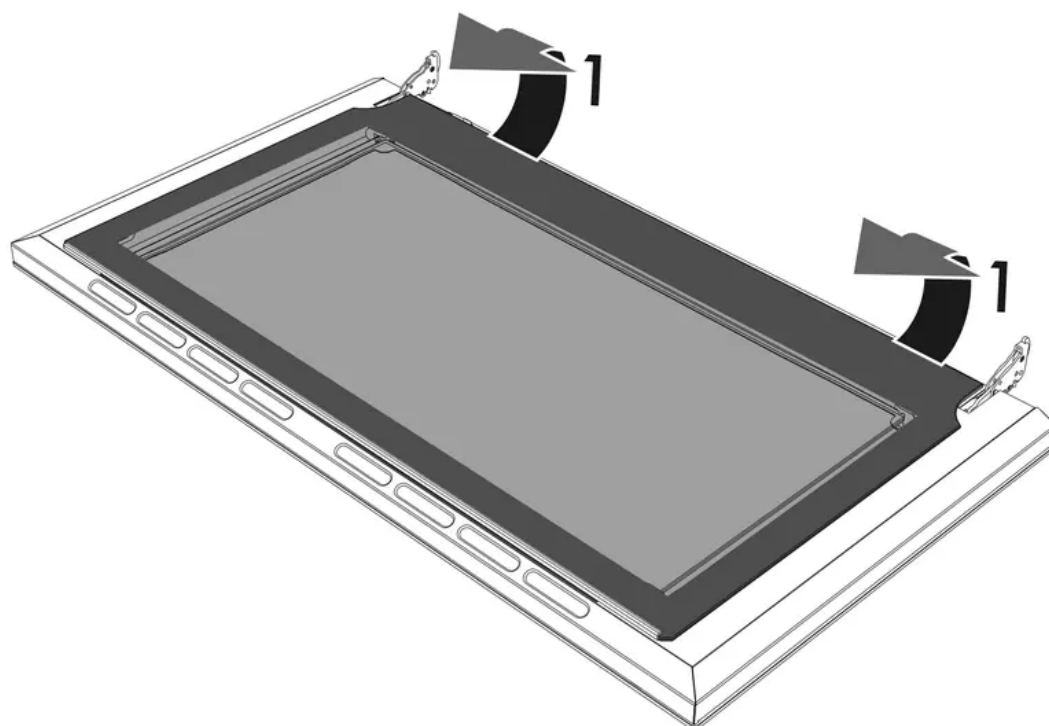

2. Extract the internal glass pane from the front strip (2) to remove it from the door.

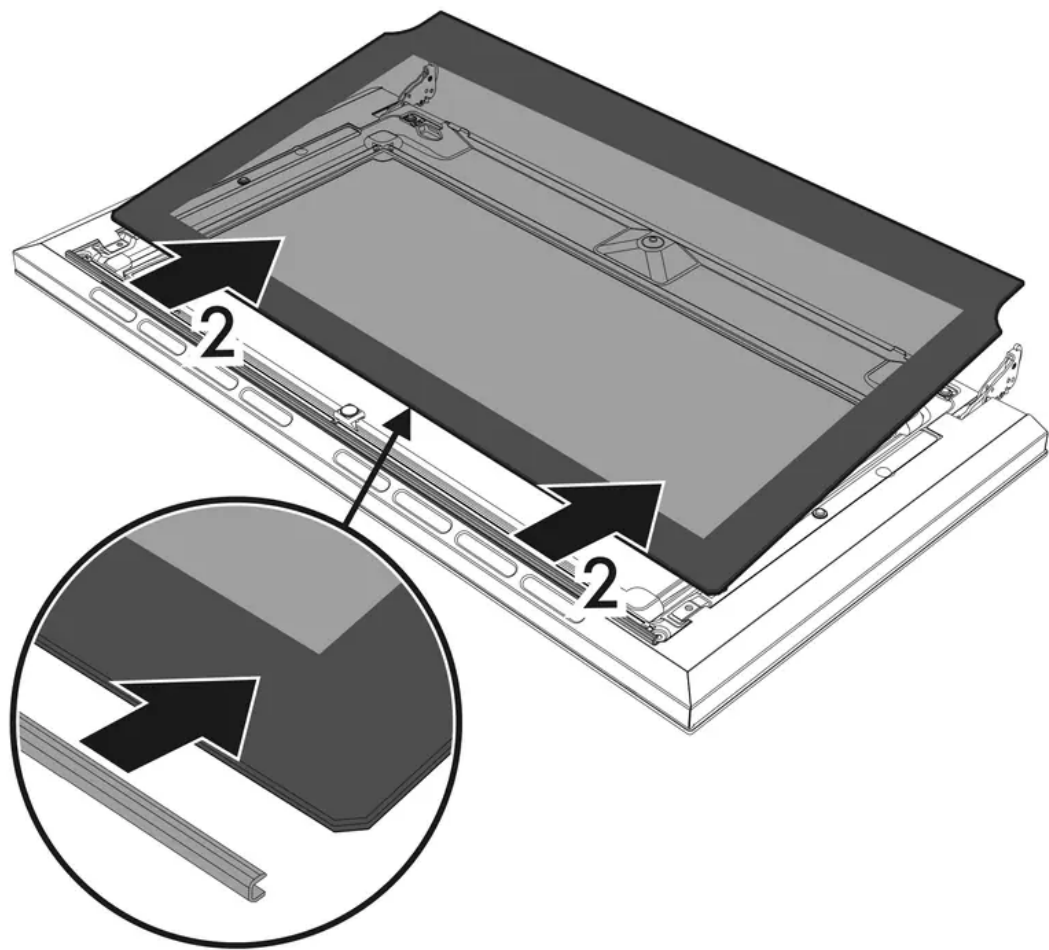

3. Remove the intermediate glass pane by lifting it upwards.

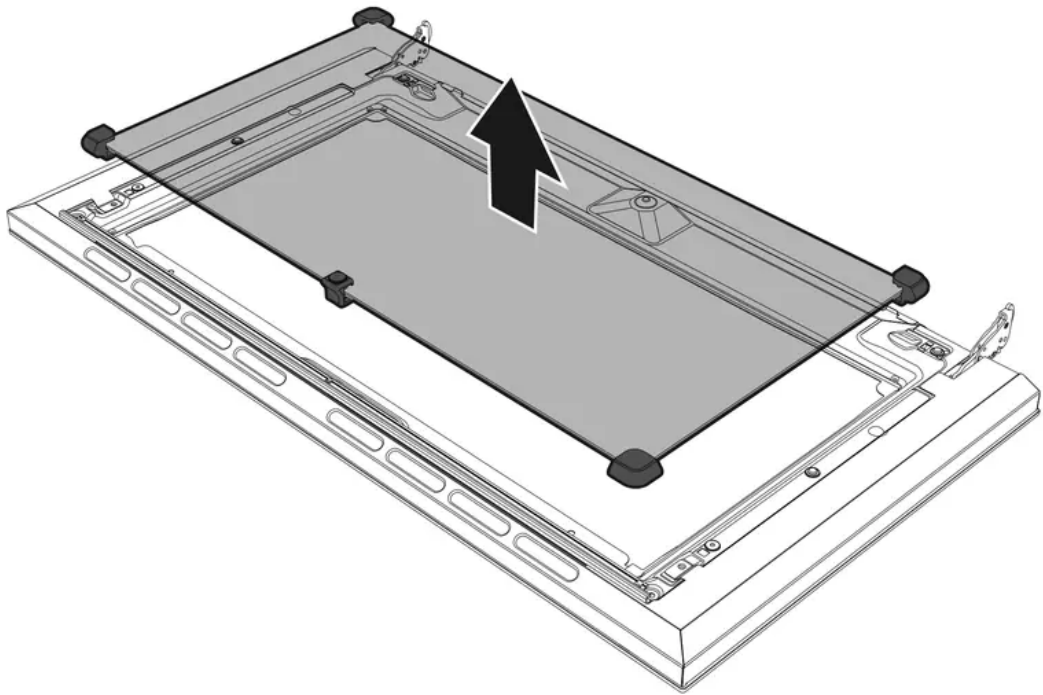

Note: The pyrolytic model has two intermediate glass panes.

4. Clean the external glass pane and the panes removed previously. Use absorbent kitchen roll. In case of stubborn dirt, wash with a damp sponge and neutral detergent.

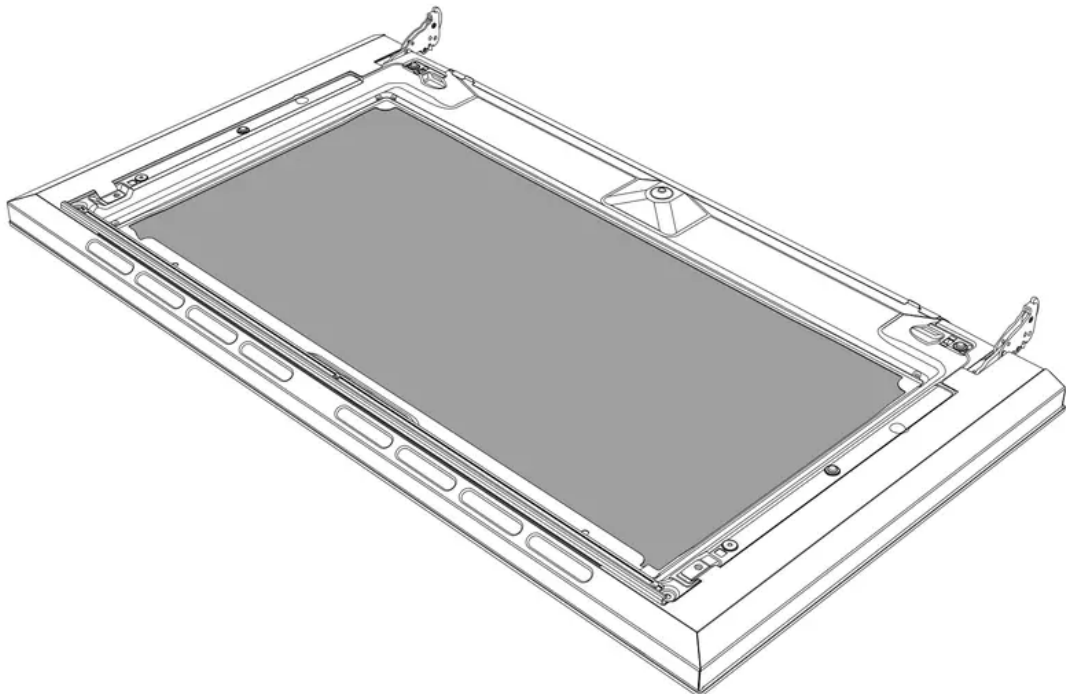

5. When you have finished cleaning, reinsert the intermediate glass pane in its housing in the door.

6. To reposition the internal glass pane, slide the upper part into the door strip and insert the two rear pins into their seats by pressing lightly.

Removing racks/trays support frames

Removing the rack/tray support frames enables the sides to be cleaned more easily.

To remove the rack/tray support frames:

- Pull the frame towards the inside of the oven to unhook it from its groove **A**, then slide it out of the seats **B** at the back.

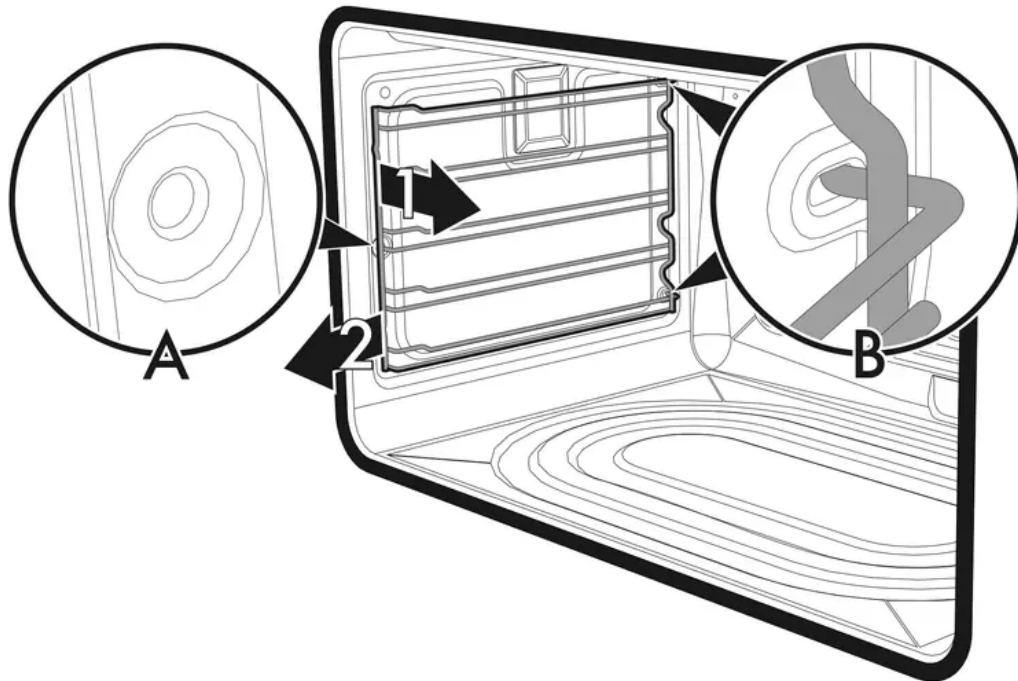

- When cleaning is complete, repeat the above procedures to put the rack/tray support frames back in.

Manual deactivation of the door lock lever (pyrolytic models only)

Caution: Improper use - Danger of burns

- The following operations must always be performed with the appliance cold and switched off.
- Never attempt to manually deactivate the door lock lever during a pyrolytic cycle.

The door lock lever is located in the first slot on the left under the control panel, in the upper part of the front of the oven.

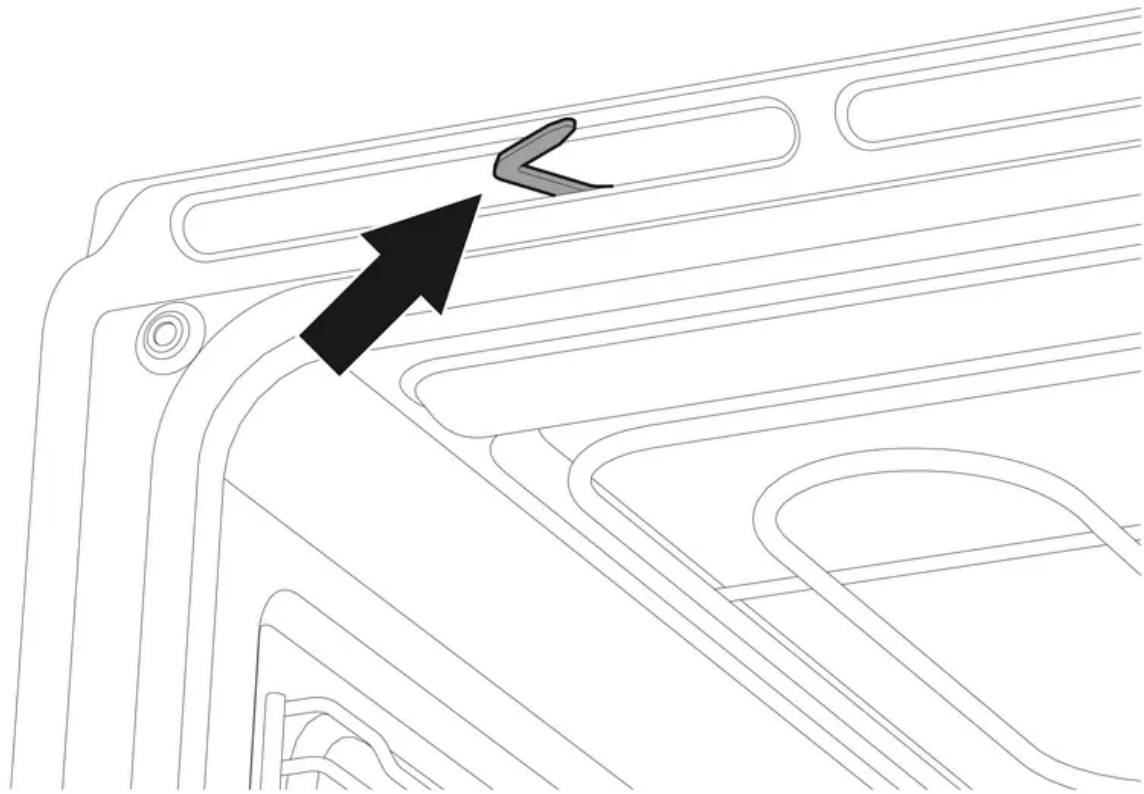

During normal cleaning operations, it is possible to accidentally activate the door lock lever.

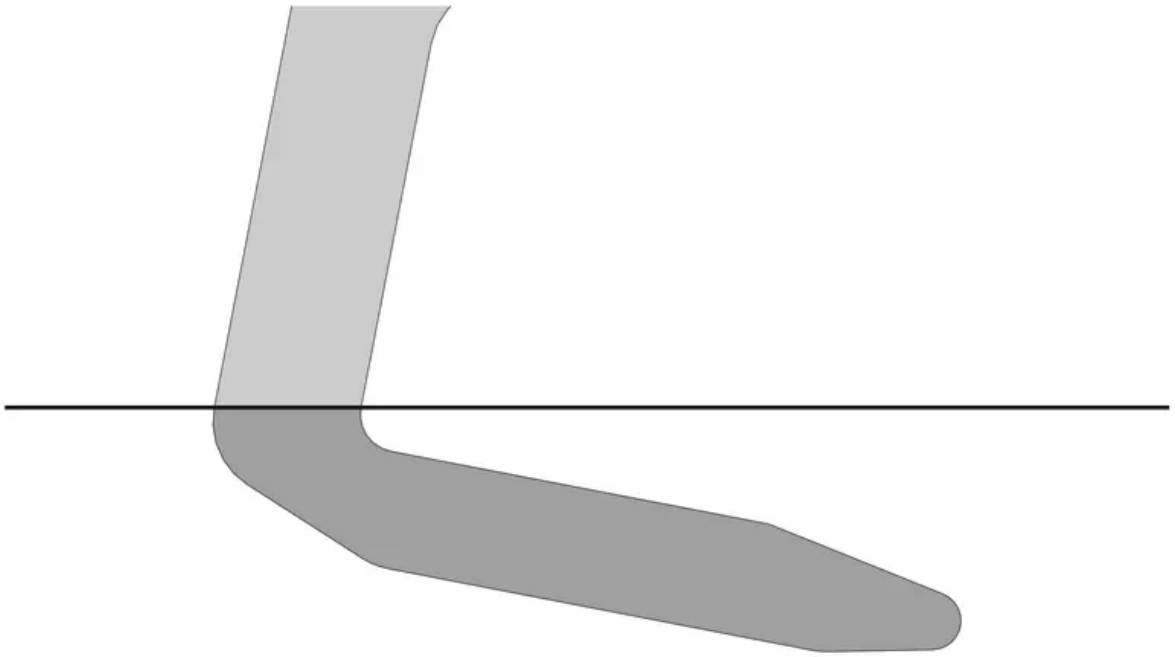

**Door lock lever activated
(view from above)**

1. Move the door lock lever to the right until it stops.

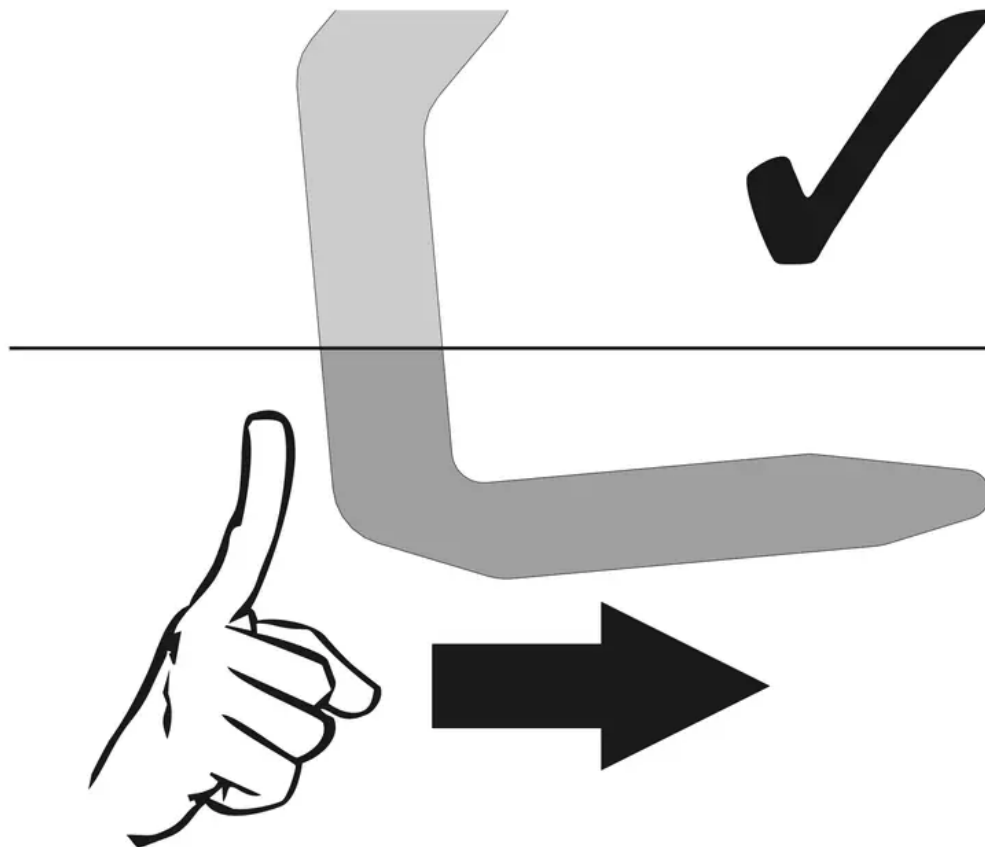

(view from above)

2. Gently release the door lock lever.

The mechanism's spring will return the door lock lever to the deactivated position.

To prevent damage to the mechanism, never attempt to deactivate the door lock lever by

forcing it to the left.

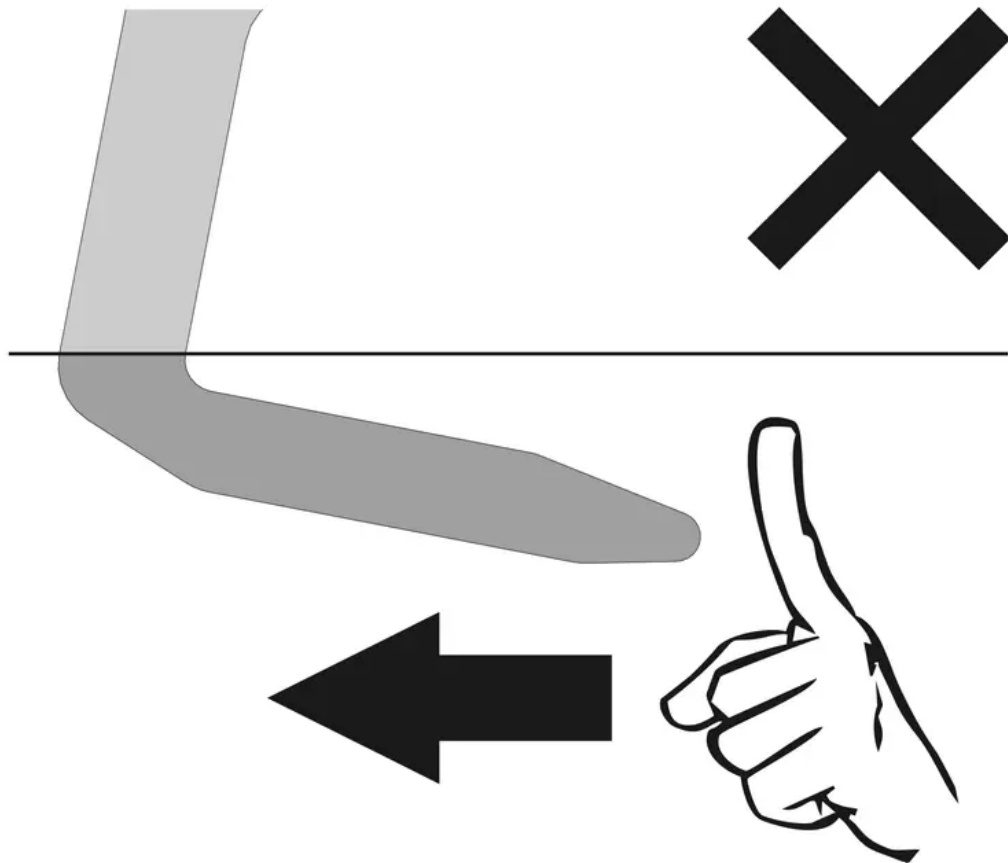

(view from above)

Cleaning the top section (not on pyrolytic models)

The oven cavity is fitted with a tilting heating element which facilitates cleaning the top part (roof) of the oven.

1. Free the upper heating element by gently lifting it and rotating its retainers by 90 degrees.

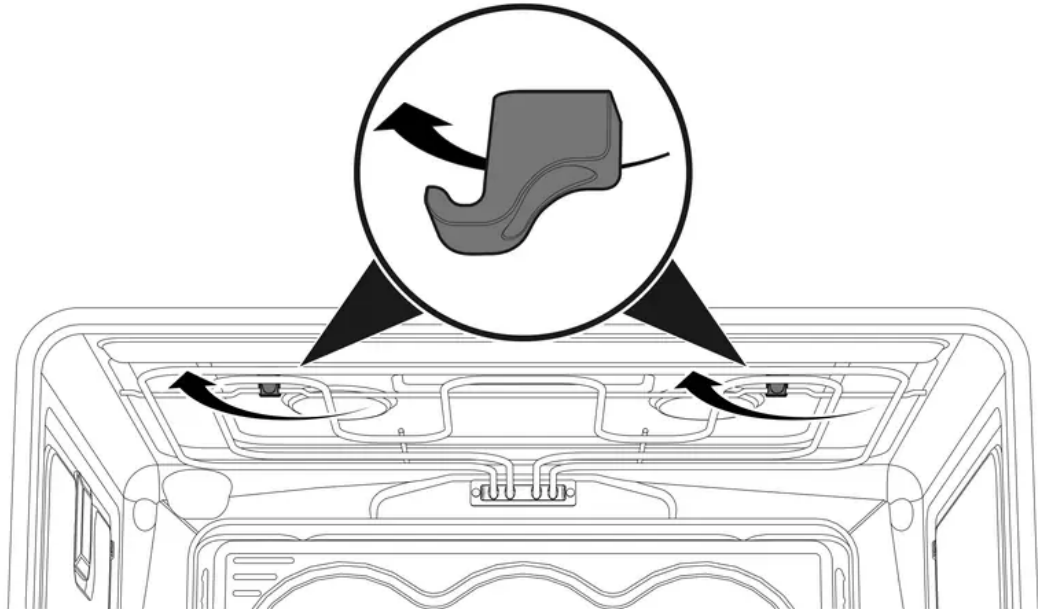

2. Gently lower the heating element until it stops.

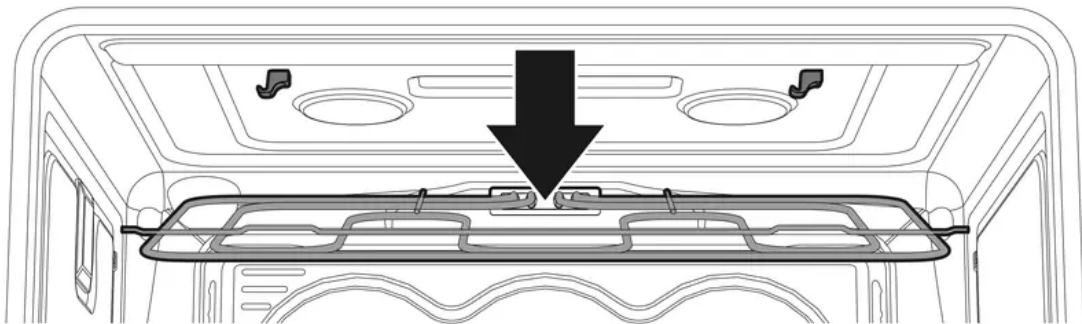

Caution: Improper use - Risk of damage to the appliance

Do not excessively flex the element during cleaning.

3. When you have finished cleaning, place the heating element back in position and turn the retainers to lock it in place again.

Vapor Clean (on some models only)

Important: Vapor Clean is an assisted cleaning procedure which facilitates the removal of dirt. Thanks to this process, it is possible to clean the inside of the oven very easily. The dirt residues are softened by the heat and water vapour for easier removal afterwards.

Caution: Improper use - Risk of damage to surfaces

- Remove any food residues or large spills from previous cooking operations from the inside of the oven.

- Carry out assisted oven cleaning operations only when the oven is cold.

Preliminary operations

Before starting the Vapor Clean function:

- Completely remove all accessories from inside the oven.
- Remove the rack/tray support frames.
- Detach removable guides, where fitted.
- Close the door.
- Pour approximately 40 cc of water into the tray. Make sure it does not overflow out of the cavity.

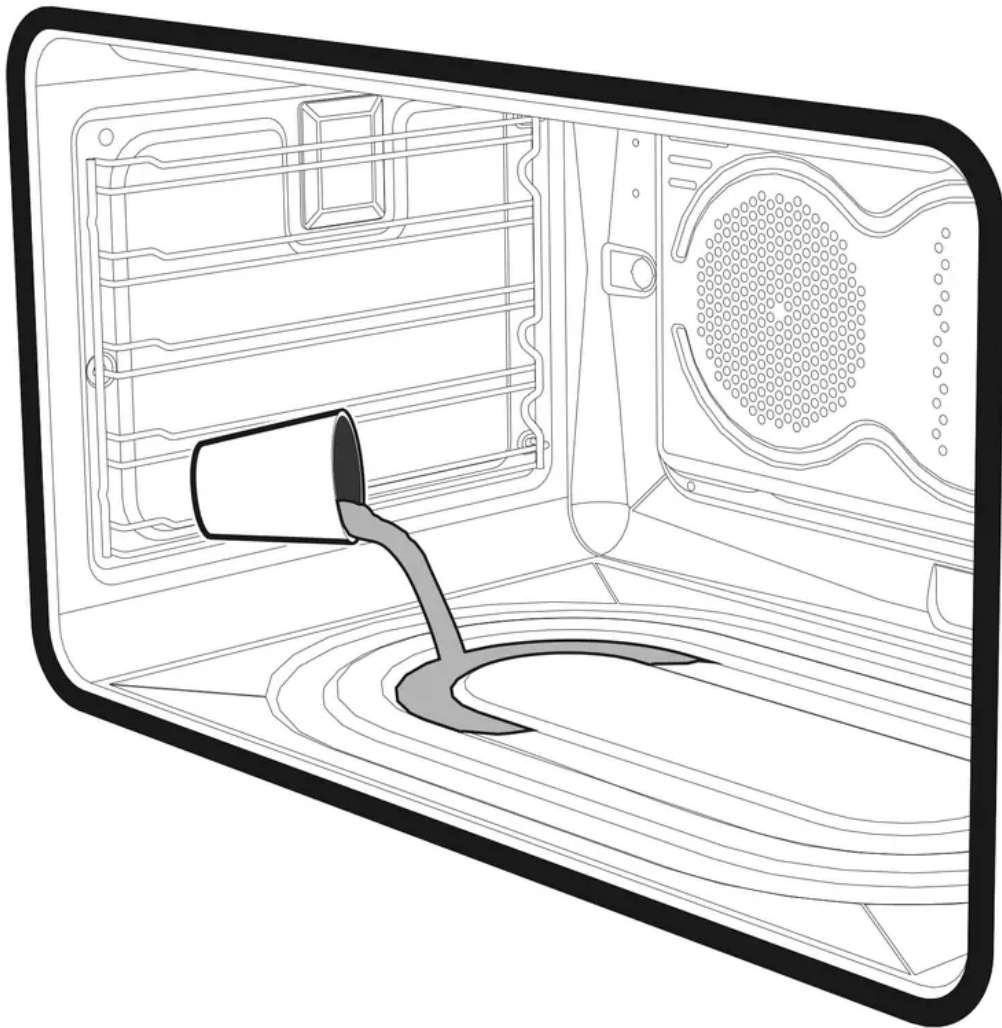

- Spray a water and washing up liquid solution inside the oven using a spray nozzle. Direct the spray against the side walls, upwards, downwards and towards the deflector.

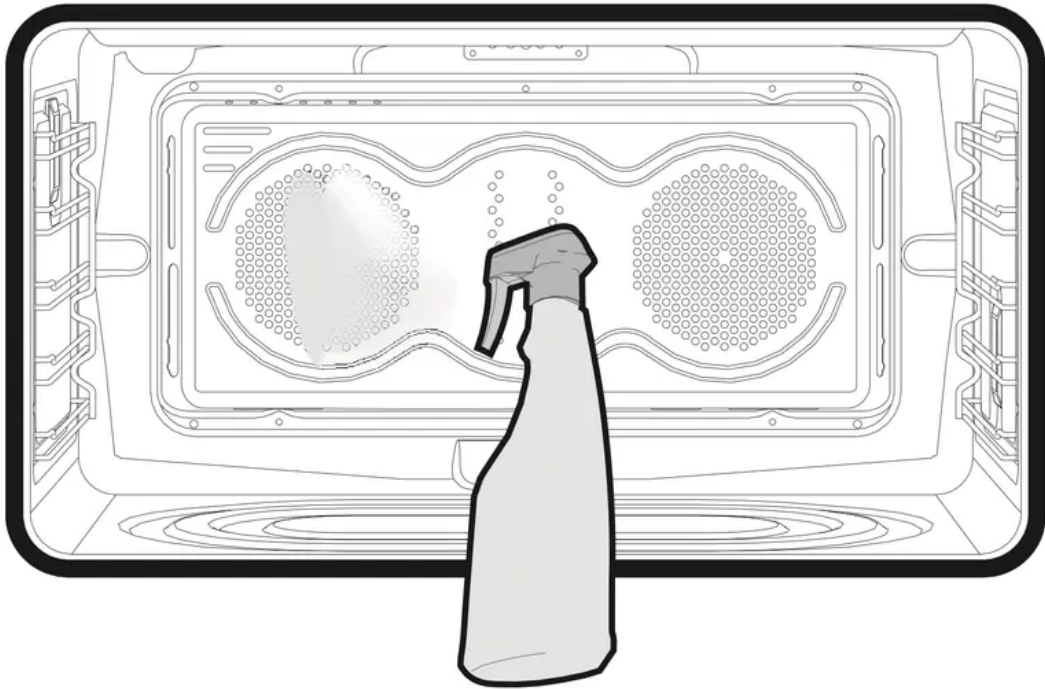

- Close the door.

Note: We recommend spraying approx. 20 times at the most.

Vapor Clean cycle setting

Important: If the internal temperature is greater than that required for the Vapor Clean cycle, the

cycle will be stopped immediately and the **STOP** message will appear on the display. Let the appliance cool down before activating the assisted cleaning cycle.

1.

Press and turn the function knob to select the Vapor Clean function . The duration and temperature of the cleaning cycle will appear on the display.

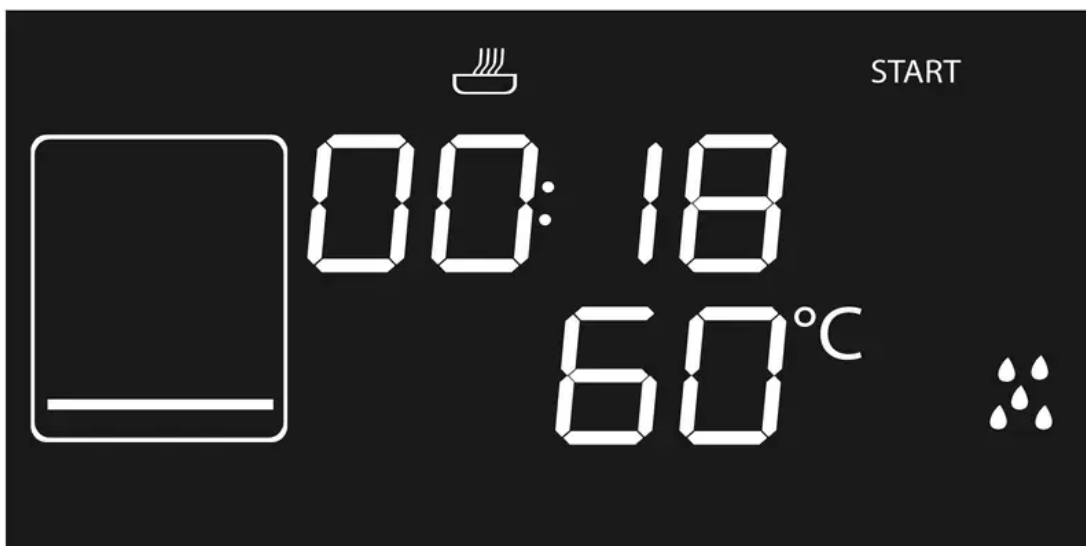

Note: The temperature and time parameters cannot be modified by the user.

2. Press the function knob to start the automatic cleaning cycle.

Programmed Vapor Clean cycle

Like for the normal cooking functions, it is also possible to set an end time for the Vapor Clean function.

1. After selecting the Vapor Clean function, press the temperature knob. The indicator light



starts flashing. The display shows the function end time.



2. Turn the temperature knob right or left to delay the cooking end time.
3. Press the temperature knob to confirm the function end time.
4. Press the function knob. The appliance waits for the set start time.

End of the Vapor Clean cycle



At the end,  is displayed and a buzzer sounds.

1. To deactivate the buzzer, press or turn one of the two knobs or open the door.
2. Press and hold the function knob for at least 3 seconds to exit the function.
3. Open the door and wipe away the less stubborn dirt with a microfibre cloth.
4. Use a non-scratch sponge with brass filaments on hard to remove deposits.
5. In case of grease residues use specific oven cleaning products.
6. Remove the residual water inside the oven.

For improved hygiene and to avoid food being affected by any unpleasant odours, we recommend that the oven is dried using a fan-assisted function at 160°C for approximately 10 minutes.

Note: We recommend wearing rubber gloves for these operations.

Note: We recommend removing the door in order to make the manual cleaning of the parts that are difficult to reach easier.

Pyrolytic (on some models only)

Important: Pyrolytic cleaning is an automatic high-temperature cleaning procedure which causes dirt to dissolve. Thanks to this process, it is possible to clean the inside of the oven very easily.

Caution: Improper use - Risk of damage to surfaces

- Remove any food residues or large spills from previous cooking operations from the inside of the oven.

Preliminary operations

Before starting the pyrolytic cycle:

- Clean the internal glass pane following the usual cleaning instructions.
- For very stubborn encrustations spray an oven cleaning product onto the glass (read the warnings on the product); leave for 60 minutes, then rinse and dry the glass using kitchen roll or a microfibre cloth.
- Completely remove all accessories from inside the oven.
- Remove the rack/tray support frames.
- Detach removable guides, where fitted.
- Close the door.

Pyrolytic function setting

1. Select one of the cleaning functions  or  with the function knob.

2. Turn the temperature knob to the right or to the left to set the cleaning cycle duration

from a minimum of 2 hours to a maximum of 3 hours (except for  the function whose duration is 120 minutes).

3. Press the temperature knob to start the pyrolytic cycle.

Note: Recommended pyrolytic cycle duration:

- Light dirt: 2 hours.
- Medium dirt: 2 ½ hours.
- Heavy dirt: 3 hours.

Pyrolytic cycle

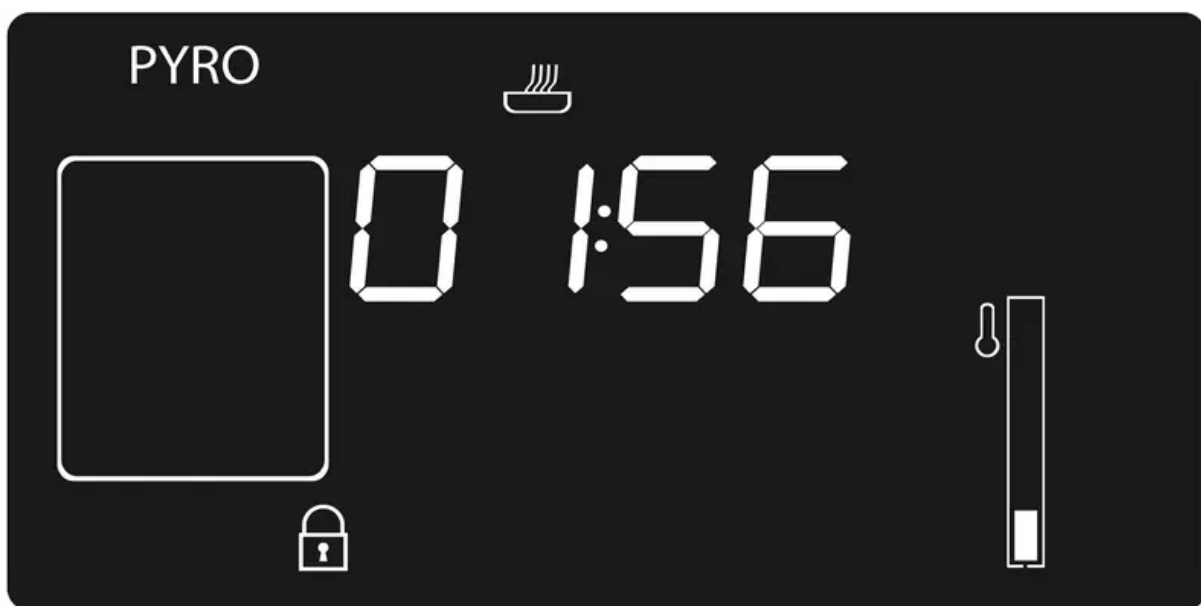

1.

The display shows  or  and the remaining time to indicate that the appliance is carrying out the automatic cleaning cycle.

2. Two minutes after the pyrolytic cycle has started the door is locked (the door lock

indicator light  comes on) by a device that prevents the door from being opened.

Important: It is not possible to select any function once the door lock device has been activated.

3. At the end of the pyrolytic cycle, the door remains locked as long as the temperature inside the oven cavity returns to safety levels. Wait for the oven to cool down and collect the residue deposited inside it using a damp microfibre cloth.

Important: During the first pyrolytic cycle, unpleasant odours may occur due to the normal evaporation of oily manufacturing substances. This is an absolutely normal phenomenon which disappears after the first pyrolytic cycle.

Important: During the pyrolytic cycle the fans produce a more intense level of noise due to a greater rotation speed. This is an absolutely normal operation, intended to provide more effective heat dispersal. At the end of the pyrolytic cycle, the fans will continue to operate for long enough to avoid overheating the walls of adjacent units and the front of the oven.

Note: If the pyrolytic cycle gives unsatisfactory results at minimum duration, it is recommended to set a longer time for successive cleaning cycles.

Setting of programmed pyrolytic cycle

It is possible to program the pyrolytic cycle start time like all other cooking functions.

1. After selecting the pyrolytic cycle duration, press the temperature knob. The display



shows the current time and the indicator light comes on.

2. Turn the temperature knob to set the time at which you wish to complete the pyrolytic cycle.

- 3.



After a few seconds, the and indicator lights will turn on steadily and the appliance will now wait for the set start time to start the cleaning cycle.

Important: It is not possible to select any function once the door lock device has been activated.

Extraordinary maintenance

Replacing the internal light bulb

Caution: Live parts - Danger of electrocution

- Unplug the appliance.

Note: The oven is fitted with a 40W light bulb.

1. Completely remove all accessories from inside the oven.
2. Remove the rack/tray support frames.

3. Remove the bulb cover using a tool (e.g. a screwdriver).

Note: Pay attention not to scratch the oven cavity enamel.

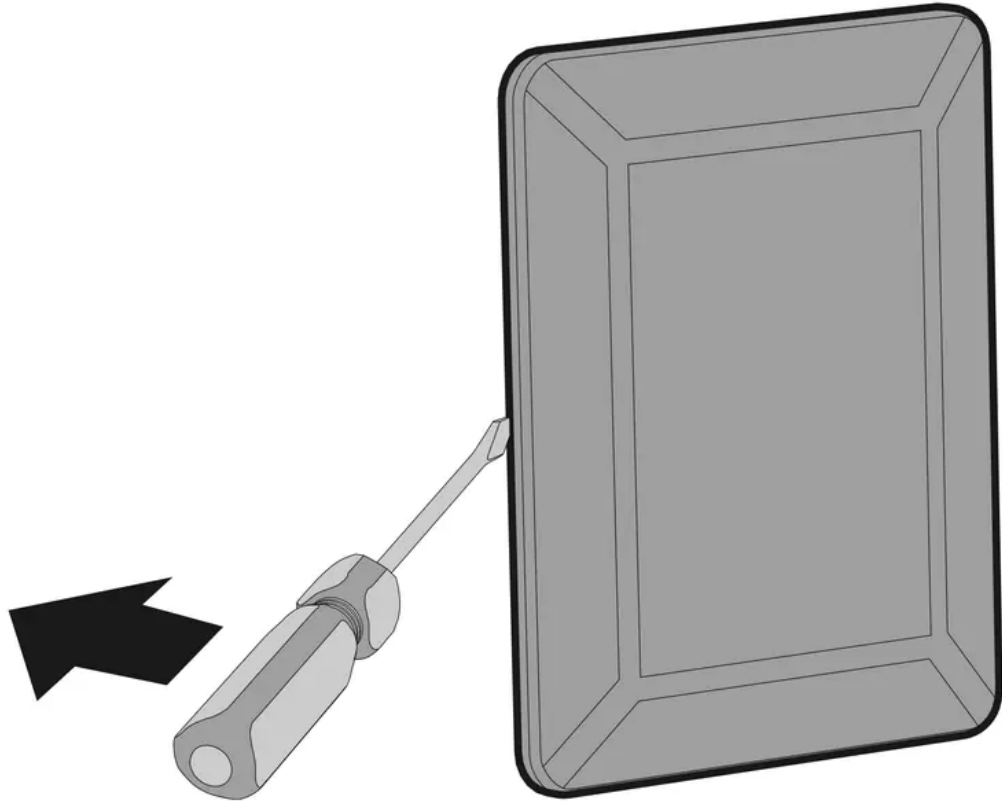

4. Slide out and remove the light bulb.

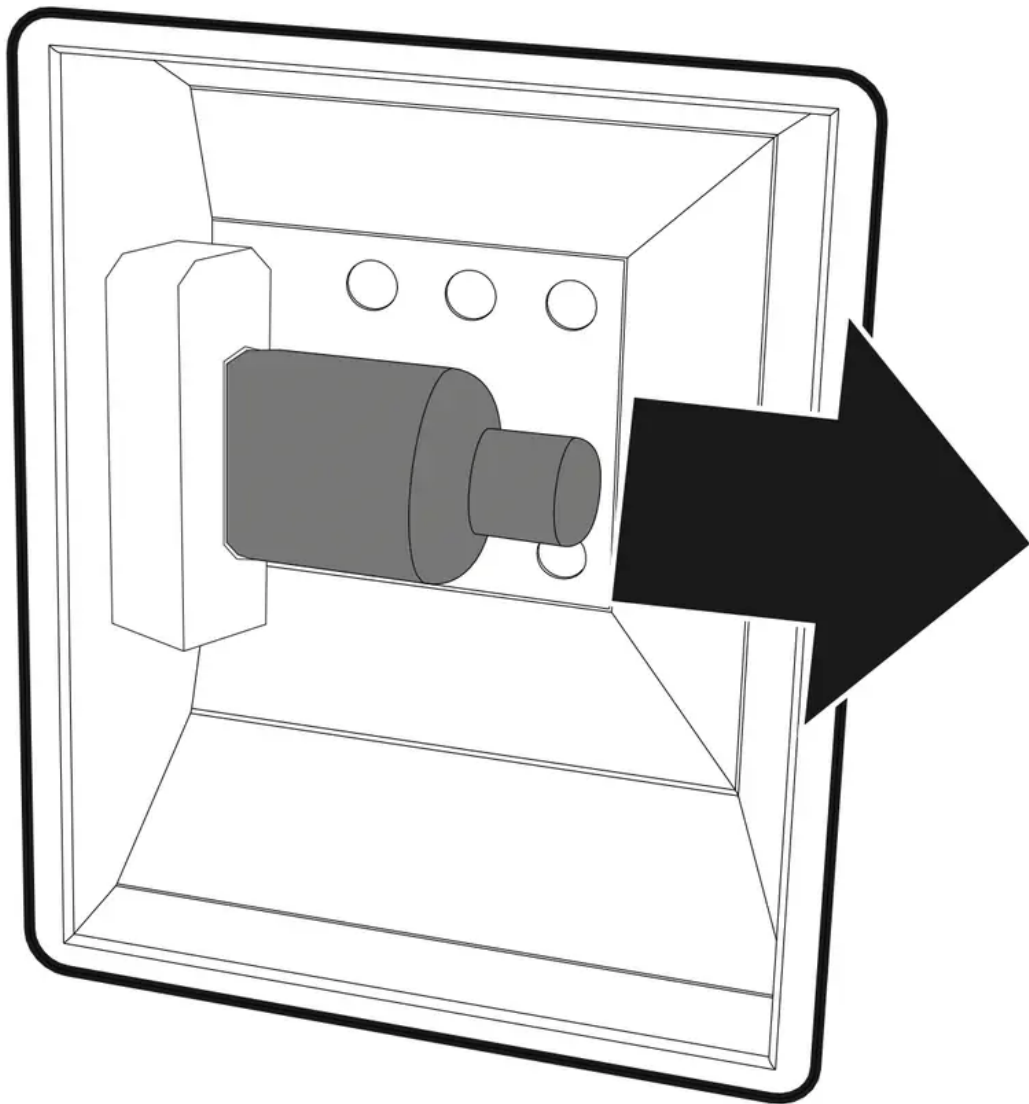

Note: Do not touch the halogen light bulb directly with your fingers, but wrap it in insulating material.

5. Fit the new light bulb.

6. Refit the cover. Ensure the moulded part of the glass (A) is facing the door.

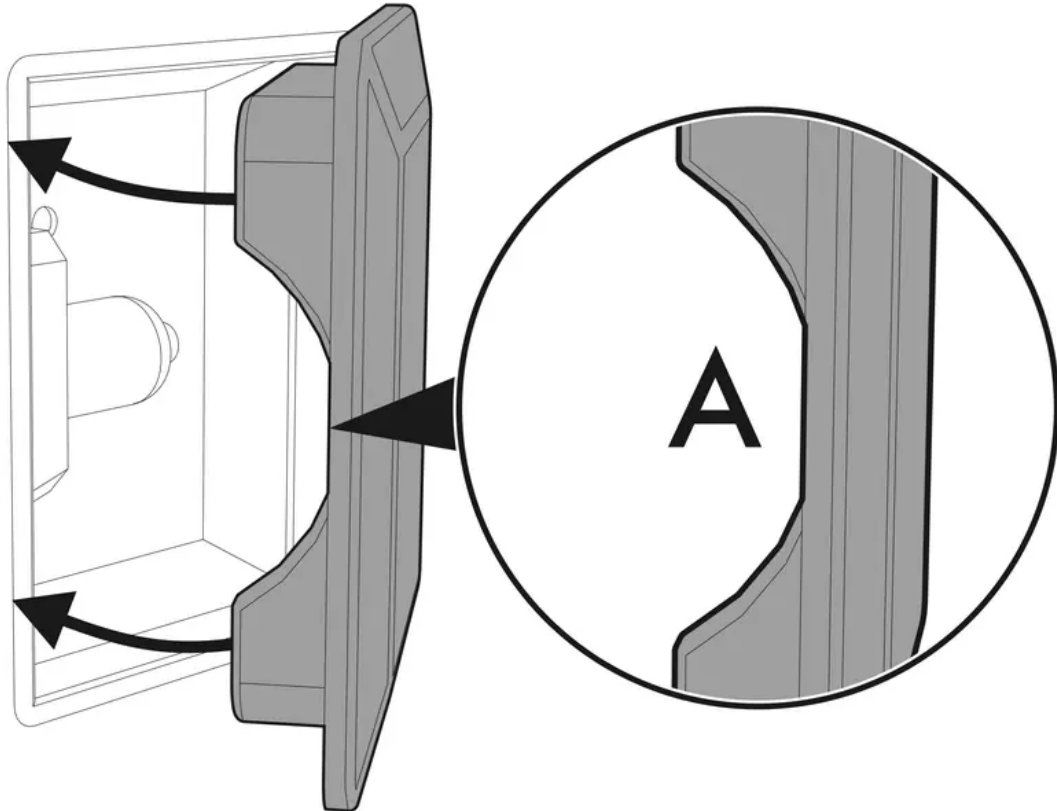

7. Press the cover completely down so that it attaches perfectly to the bulb support.

Removing and installing the door seal (not on pyrolytic models)

To remove the seal:

- Unhook the clips located in the 4 corners and in the centre, then pull the seal outwards.

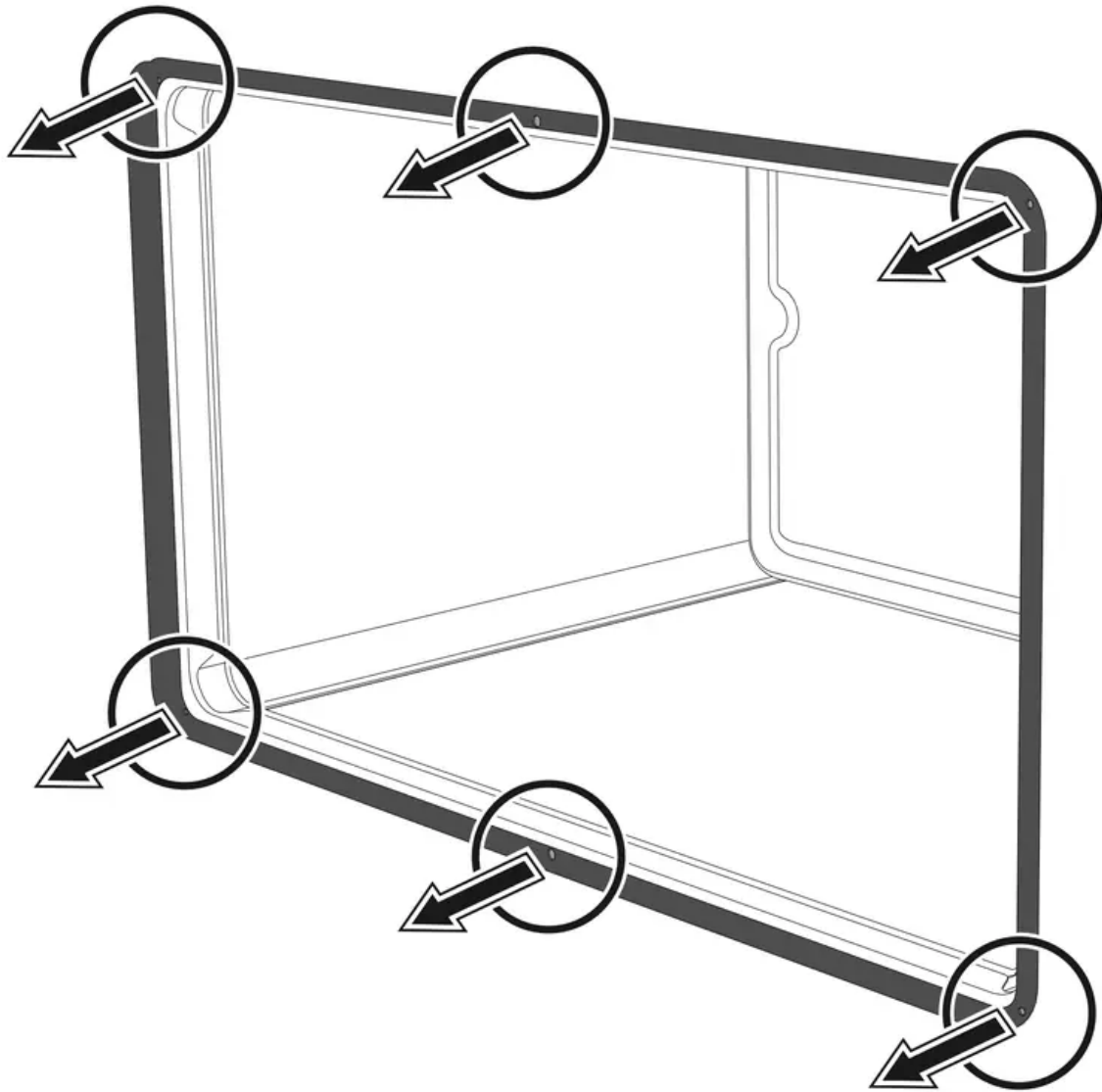

To refit the seal:

- Hook the clips located in the 4 corners and in the centre onto the seal.

Seal maintenance tips

The seal should be soft and elastic.

- To keep the seal clean, use a non-abrasive sponge and wash with lukewarm water.

Troubleshooting

The appliance is not working properly:

- The switch is defective: check the fuse box to see whether the switch is in working order.
- Loss of power: check that the appliance indicator lights are operational.

The gas burner does not light:

- Loss of power or moisture in the igniters: light the gas burner with a lighter or match.

The oven does not heat up:

- Defective fuse: check and replace the switch if necessary.
- The function knob has not been set: set the function knob.
- Check whether it has been set to “showroom” mode (for further details see “Secondary menu”).

All food prepared in the oven burns within a short time:

- Defective thermostat: contact an Authorised Service Centre

The door glass mists up when the oven is hot:

- Completely normal behaviour caused by the difference in temperature which has no effect on the oven’s performance.

The display is completely off:

- Check the mains power supply.
- Check whether an omnipolar switch upstream of the appliance supply line is in the “ON” position.

The controls do not respond:

- Check whether “child lock” mode has been set (for further details see “Secondary menu”).

The cooking times are longer than those indicated in the table:

- Check whether it has been set in “ecologic” mode (for further details see “Secondary menu”).

The display shows “ERR4”:

- The door lock has not properly attached to the door. This might be because the door was accidentally opened during the door lock activation. Switch the appliance off and on again, waiting a few minutes before selecting a new cleaning cycle.

If the door is opened during a fan assisted function, the fan stops:

- This is not a fault. It is a normal operation of the appliance, useful when cooking foods in order to avoid excessive heat escaping. When the door is closed, the oven will return to normal operation.

(pyrolytic models only) After the (pyrolytic) automatic cleaning cycle it is not possible to select a function:

- Verify whether the door lock has deactivated. If it has not, the appliance is fitted with a safety device that does not allow functions to be selected while the door lock is active. This is because the temperature inside the oven is still too high to permit any type of cooking.

Note: If the problem has not been resolved or in the case of other types of fault, contact your local technical support centre.

Note: If other ERRx error messages are indicated: Note down the error message, function and set temperature and contact your local technical support centre.

Warning

This content is compiled from multiple sources and is provided for reference purposes only. It may not be complete or fully applicable to all situations. If you are unable to resolve your issue, please contact the product manufacturer or an authorized service provider for official support.