



LIVE WITH
i ILVE
IDEAS



Built-in Microwave Operating & Installation Manual







OPEN 24/7
ILVE ACCESSORIES ONLINE SHOP

For a wide range of coffee machines, pods, and other ILVE accessories at the click of a button shop.ilve.com.au

Congratulations,



you are now the proud owner of an ILVE cooking appliance. Thank you for purchasing ILVE and welcome to the exciting world of cooking the ILVE way.

This instruction manual has been specially created to inform you of the full range of features your ILVE appliance has to offer and serves as an introduction to the wonderful benefits of ILVE's dynamic cooking systems.

We present detailed information on each of the advanced cooking systems built into ILVE appliances. Once you have read this section you will be able to choose the most appropriate settings for your appliance when cooking different types of food.

Please carefully READ these instructions BEFORE INSTALLING AND USING the appliance and retain them for future reference. It is important that you keep potentially hazardous packaging (plastic bags, polystyrene, etc.) out of reach of children.



Contents

Warning and Safety instructions	6
Modes of Operation	11
Suitable Containers for Microwave Ovens	12
Operation	14
Cleaning and Care	18
Installation	19
Warranty Card	21

Warning and Safety Instructions

- THIS APPLIANCE IS NOT INTENDED FOR USE BY PERSONS (INCLUDING CHILDREN) WITH REDUCED PHYSICAL, SENSORY OR MENTAL CAPABILITIES, OR LACK OF EXPERIENCE AND KNOWLEDGE, UNLESS THEY HAVE BEEN GIVEN SUPERVISION OR INSTRUCTION CONCERNING USE OF THE APPLIANCE BY A PERSON RESPONSIBLE FOR THEIR SAFETY. CHILDREN SHOULD BE SUPERVISED TO ENSURE THAT THEY DO NOT PLAY WITH THE APPLIANCE
- During use the appliance becomes hot. Care should be taken to avoid touching heating elements inside the oven.
- Accessible parts may become hot during use Young children should be kept away.
- When this appliance is operated in the combination mode, children should be in adult supervision due to the temperatures generated.
- If the door or door seals are damaged, the oven must not be operated until it has been repaired by a competent person.
- It is hazardous for anyone other than a competent person to carry out any service or repair operation that involves the removal of a cover which gives protection against exposure to microwave energy.
- Liquids and other foods must not be heated in sealed containers as they are liable to explode. When heating liquids, milk, sauces etc. the boiling point of the liquid may be reached without the production of typical bubbles. The liquid does not boil evenly throughout. This so-called 'boiling delay' can cause a sudden build-up of bubbles when the container is removed from the oven or shaken, which can lead to the liquid boiling over suddenly and explosively and can cause skin burning.
- Only allow children to use the oven with supervision when adequate instructions have been given so that the child is able to use the oven in a safe way and understands the hazards of improper use.
- When heating food in plastic or paper containers, keep an eye on the oven due to the possibility of ignition. If smoke is observed, switch off or unplug the appliance and keep the door closed in order to stifle any flames.
- Microwave heating of beverages can result in delayed eruptive boiling; therefore care must be taken when handling the container.
- Failure to maintain the oven in a clean condition could lead to deterioration of the surface that could adversely affect the life of the appliance and possibly result in a hazardous situation. Improper use can present a risk of both personal injury and material damage. To avoid the risk of accidents and damage to the appliance please read these operating instructions carefully before installation and before using it for the first time. They contain important notes on installation, safety, operation and care of the appliance. Keep these instructions in a safe place and pass them on to any future user.
- Do not use harsh abrasive cleaners or sharp metal scrapers to clean the oven door glass since they can scratch the surface, which may result in shattering of the glass. A steam cleaner is not to be used.
- This appliance complies with all relevant local and national safety requirements.
- The appliance is intended for domestic use only: to cook, defrost, reheat and to grill food. Any other usage is not supported by the manufacturer and could be dangerous. The manufacturer cannot be held liable for damage caused by improper or incorrect use of the appliance. Never use the microwave to store or dry items which could ignite easily. Moisture evaporates and create a Fire hazard.
- This appliance is not a toy! To avoid the risk of injury, do not allow children to play on or near it or to play with the controls.

- Supervise its use by older children, the elderly or infirm. If allowing older children to use the appliance without supervision, please ensure that they are aware of how a microwave oven works and understand the dangers of improper use.

Technical safety

- If the connection cable is damaged, the new cable must be fitted by a ILVE approved service technician.
- Do not use the microwave if the door is warped, the door hinges are loose, holes or cracks are visible in the casing, the door or the oven interior walls. Operating the appliance with this type of damage will result in microwave leakage and present a hazard to the user.
- Never open the casing of the appliance. Tampering with electrical connections or components and mechanical parts is highly dangerous and can cause operational faults or electric shock.
- Before connecting the appliance to the mains supply, make sure that the rating on the data plate corresponds to the voltage and frequency of the household supply. This data must correspond in order to avoid risk of damage to the appliance. Consult a qualified electrician if in any doubt.
- Do not connect the appliance to the mains electricity supply by an extension lead. Extension leads do not guarantee the required safety of the appliance (e.g. danger of overheating).
- The electrical safety of this appliance can only be guaranteed when continuity is complete between it and an effective earthing system which complies with local and national safety regulations. It is most important that this basic safety requirement is present and regularly tested and where there is any doubt, the on-site electrical wiring should be inspected by a qualified electrician. The manufacturer cannot be held liable for the consequences of an inadequate earthing system (e.g. electric shock).
- The appliance must be built in before operation to ensure that no electrical components are accessible.
- Repairs may only be carried out by a suitably qualified and competent person in accordance with national and local safety regulations. Repairs and other work by unqualified persons could be dangerous. The manufacturer cannot be held liable for unauthorised work.
- The appliance is only completely isolated from the electricity supply when it is switched off at the wall socket and the plug removed or the mains fuse is disconnected or the screw-out fuse is removed (in countries where this is applicable).
- This equipment may only be used in mobile installations such as ships, caravans, aircraft etc. if a risk assessment of the installation has been carried out by a suitably qualified engineer.
- In countries where there are areas which may be subject to infestation by cockroaches or other vermin, pay particular attention to keeping the appliance and its surroundings in a clean condition at all times. Any damage which may be caused by cockroaches or other vermin will not be covered by the guarantee.

Warning and Safety Instructions

Using the Microwave Oven

- Always ensure that food is sufficiently heated.
- Many factors will affect the overall cooking time, including the size and amount of food, its initial temperature, changes to the recipe and the shape and size of cooking container.
- Some foods may contain micro-organisms which are only destroyed by thorough cooking, therefore when cooking or reheating foods, e.g. poultry, it is particularly important that food is fully cooked through (at temperatures over 70°C for more than 10 minutes). If in doubt, select a longer cooking or reheating time.
- It is important that the heat is allowed to spread evenly throughout the food being cooked. This can be achieved by stirring and/or turning the food, and by observing a sufficiently long standing time, which should be added to the time needed for cooking, reheating or defrosting.
- Always remember that times for cooking, reheating and defrosting in a microwave oven are usually considerably shorter than with traditional methods of food preparation.
- Excessively long cooking times can lead to food drying out and burning, or could even cause it to catch fire. There is also a danger of fire if breadcrumbs, flowers, herbs, etc., are dried in the microwave oven.
- Always ensure that this type of procedure is supervised.
- Do not use the microwave function to heat up cushions or pads filled with cherry kernels, wheat grains, lavender or gel, such as those used in aromatherapy. These pads can ignite when heated, even after they have been removed from the microwave.
- Exercise caution when cooking or reheating food with a high sugar content, e.g. Christmas pudding. If heated for too long, the sugar may caramelize or ignite.
- Do not use full power to warm empty dishes.
- Do not use the appliance without food, or if it is incorrectly loaded.
- Never cook or reheat food or liquids in sealed containers, jars or bottles. With baby bottles, the screw top and teat must be removed. Otherwise pressure builds up which can cause the bottle or container to explode, posing a severe risk of injury.
- Before serving, remember to allow a sufficient standing time and then always check the temperature of the actual food itself after taking it out of the microwave. The temperature of the container is not an indication of the temperature of the food or liquid in it. This is particularly important when preparing food for babies, children, and the elderly or infirm. Shake or stir baby milk and food thoroughly after heating, and try it for temperature to ensure that it will not scald the baby. When heating food and drink remember that the heat is created in the food itself, and that the container will normally be cooler. The dish is only warmed by the heat of the food.

- To avoid fuelling any flames, do not open the oven door if smoke occurs in the oven interior.
- Interrupt the process by pressing the Stop/C button twice. Switch off at the wall socket, and where applicable, remove the plug. Do not open the door until the smoke has dispersed.
- Never heat undiluted alcohol in the oven as this can easily ignite.

Danger of Injury or Fire:

- Do not heat up tins in the microwave oven.
- Pressure can build up and they may explode resulting in injury or damage.
- Cover any food which is left in the oven to be kept hot, as moisture in the food could lead to corrosion damage in the oven. This also prevents the food from drying out.
- Try to avoid the interior walls being splashed with food or liquids containing salt. If it does happen, wipe these away thoroughly to avoid corrosion on the stainless steel surface.
- Do not use any containers or cutlery made from or containing metal, aluminium foil, lead crystal glassware, temperature-sensitive plastics, wooden utensils or cutlery, metal clips or wire ties. Do not use bowls with milled rims, or cream pots with the tinfoil lid only partially removed. Such items could be damaged or cause a fire hazard. The gourmet plate supplied with the appliance are designed to be compatible with microwaves and can therefore be used for grilling with or without the microwave function.
- The microwave grill rack should only be used when grilling and NOT when microwaving or using combination microwave and grill.
- Do not use the rack and the gourmet plate at the same time. This will damage the gourmet plate. Always place the gourmet plate directly on the turntable.
- Do not leave the oven unattended when reheating or cooking food in disposable containers made of plastic, paper or other inflammable materials. Before using single-use plastic containers, make sure they are suitable for use in microwave ovens. See appropriate section.
- Eggs can only be cooked in their shells in the microwave oven in a specially designed egg boiling device available from specialist shops.

Warning and Safety Instructions

- Similarly, hard-boiled eggs should not be reheated in the microwave oven as this may lead to the eggs bursting, even after they have been taken out of the oven.
- Eggs can be cooked without their shells using microwave heat only if the yolk membrane has been punctured several times first. The pressure could otherwise cause the egg yolk to explode.
- Use a suitable heat-resistant mat or pot rest.
- Do not use the oven to heat up the room. Due to the high temperatures radiated, objects left near the appliance could catch fire.
- When using kitchen appliances connected to sockets near the appliance, ensure that the cable cannot get trapped in a hot oven door, which could melt the cable insulation and be dangerous.
- To check food temperature, first interrupt the cooking process. Only use a thermometer specifically approved for food use to measure the temperature of the food. Never use a thermometer containing mercury or liquid, as these are not suitable for use with very high temperatures and will break very easily.
- Do not use a steam-cleaning appliance to clean this appliance. Pressurised steam could reach the electrical components and cause a short circuit.

When using browning dishes:

- Always use oven gloves when handling the browning dish to avoid burns.
- Never place the browning dish directly onto a table or work surface. Use a suitable heat resistant mat, grid or board to protect the work surface or table and prevent heat marks.
- Browning dishes should only be used in a microwave oven, or as a serving dish.
- In a conventional oven the special glaze would suffer damage.

Disposal of your old appliance:

- Before disposing of your old appliance, first make it unusable.
- Disconnect it from the mains, cut off the cable near the appliance and cut off and render any plug unusable. This should be done by a competent person.
- The manufacturer cannot be held liable for damage caused by non-compliance with these Warning and Safety instructions.

Modes of Operation

In a microwave oven there is a high-frequency tube called a magnetron. This converts electrical energy into microwaves. These microwaves are distributed evenly throughout the oven interior and rebound off the metal sides of the oven interior to reach the food from all sides. Microwave distribution is improved with the turntable engaged. In order for microwaves to reach the food, they must be able to penetrate the cooking utensil being used. Microwaves can penetrate porcelain, glass, cardboard and plastics, but not metal. Do not, therefore, use utensils made of metal, or which contain metal, for example in the form of gold or silver trim. The metal reflects the microwaves and this could lead to the creation of sparks. The microwaves cannot be absorbed. Microwaves pass through a suitable container and find their way directly into the food. All food contains moisture molecules which, when subjected to microwave energy, start to oscillate 2.5 thousand million times a second.

The friction caused by this vibration creates heat, which first starts developing around the outside of the food and then slowly penetrates towards centre. The moisture, fat and sugar content of food will affect the speed at which it is cooked.

As heat is produced directly in the food,

- food can generally be cooked without adding much liquid or cooking oil.
- cooking, reheating and defrosting in a microwave oven is quicker than using conventional methods.
- nutrients, such as vitamins and minerals, are generally retained.
- the colour, texture and taste of food are not impaired. Microwaves stop being produced as soon as the cooking process is interrupted or the appliance door is opened. When the appliance is in operation, the closed, sealed door prevents microwaves escaping from the appliance.

Suitable Containers for Microwave Ovens

Microwaves

- are reflected by metal,
- pass through glass, porcelain, plastic and card,
- and are absorbed by food.

Material and shape

The material and shape of containers used affect cooking results and times. Heat distribution is more even in round and oval shaped flat containers than in rectangular containers, providing better results.

Metal

Metal containers, aluminium foil and metal cutlery, or china with metallic decoration, such as gold rims or cobalt blue must not be used in an oven being used in microwave mode. The metal reflects the microwaves, hindering the cooking process.

Exceptions:

- Ready-meals in aluminium foil dishes.

These can be defrosted and reheated in the microwave oven, if recommended by the manufacturer. However, as food is only heated from the top, it is better to remove the food from the aluminium foil container and transfer it to a dish suitable for a microwave oven. The heat distribution will be more even. If sparks and arcing occur when using an aluminium container, stop and transfer the food to a microwave safe container.

- Pieces of aluminium foil

For even defrosting and to avoid overcooking unevenly shaped cuts of meat, poultry or fish, small pieces of aluminium foil may be used to mask wingtips or other thin parts for the last few minutes of the programme. Make sure that the aluminium foil is at least 2 cm from the oven walls at all times. It must not touch the walls.

- Metal meat skewers or clamps.

These should only be used if they are very small in comparison to the size of the cut of meat.

- Glassware

Heat-resistant glass or ceramic glass are ideal for use in the microwave oven. Crystal glass contains lead which could cause the glass to crack. Glass dishes with a milled rim are also subject to this risk. Both are unsuitable.

Porcelain

Porcelain is a suitable material. Do not use porcelain with gold or silver edging or items with hollow knobs or handles, as insufficient ventilation may cause pressure.

Earthenware

Decorated earthenware is only suitable if the decoration is beneath an all-over glaze. Earthenware can get very hot, and may crack.

Glazes and colours

Some glazes and colours contain metals which make them unsuitable for use in a microwave oven.

Suitable Containers for Microwave Ovens

Plastics

When purchasing plasticware, make sure that it is suitable for use in a microwave oven. Plastic containers must only be used in microwave mode alone. Plastics must be heat-resistant to a minimum of 110 °C. Otherwise the plastic may melt and fuse with the food. Special plastic utensils designed for use in microwave ovens are available from good retail outlets. Melamine is not suitable as it absorbs energy and heats up. Disposable containers, such as trays made from polystyrene, can only be used for very short timed warming and reheating of food. Plastic boiling bags can be used for cooking and reheating. They should be pierced beforehand so that steam can escape. This prevents a build-up of pressure and reduces the risk of the bag bursting. Roasting bags and tubes can also be used. Roasting tubes should be about 40 cm longer and roasting bags about 20 cm longer than the food being roasted, and carefully tied with string. Turn the ends over and secure them. The bag should be pierced according to the manufacturer's instructions. Do not use metal clips, plastic clips containing metal parts or paper ties containing wire. There is a danger that they will ignite when heated.

Wood

Wooden dishes are not suitable. Moisture contained in the wood evaporates when exposed to microwave energy, causing the wood to dry and crack.

Disposable containers

Only those plastic disposable containers which are specified by the manufacturer as suitable for use in a microwave oven may be used. Do not leave the oven unattended when reheating or cooking food in disposable containers made of plastic, paper or other inflammable materials. Disposable containers are not always recyclable or bio-degradable.

Testing dishes for their suitability

If in doubt as to whether glass, earthenware or porcelain plates or dishes are suitable for use in a microwave oven, a simple test can be performed:

Place the item you wish to test in the centre of the oven, fill a suitable glass with water and also place this in the oven.

- Close the door.
- Turn the power selector to 900 W.
- Enter a time of 30 seconds with the time selector.
- Press the Start button.

At the end of the test, the water in the glass should be warm and the dish cool. If the dish is hot the water cold it would be unwise to use the dish.

If a crackling noise is heard accompanied by sparks during the test, switch the appliance off immediately (press button Stop/C twice).

Any crockery which causes this reaction is unsuitable for use with microwave power.

If any doubt exists about the suitability of containers, please contact the supplier.

This test cannot be used to check whether items with hollow knobs or handles are suitable for use with microwave power.

Operation

Interior and Accessories

- 1- Oven door
- 2- Door locking mechanism
- 3- Grill/browning element
- 4- Control panel
- 5- Turntable
- 6- Grilling rack
- 7- Turntable support

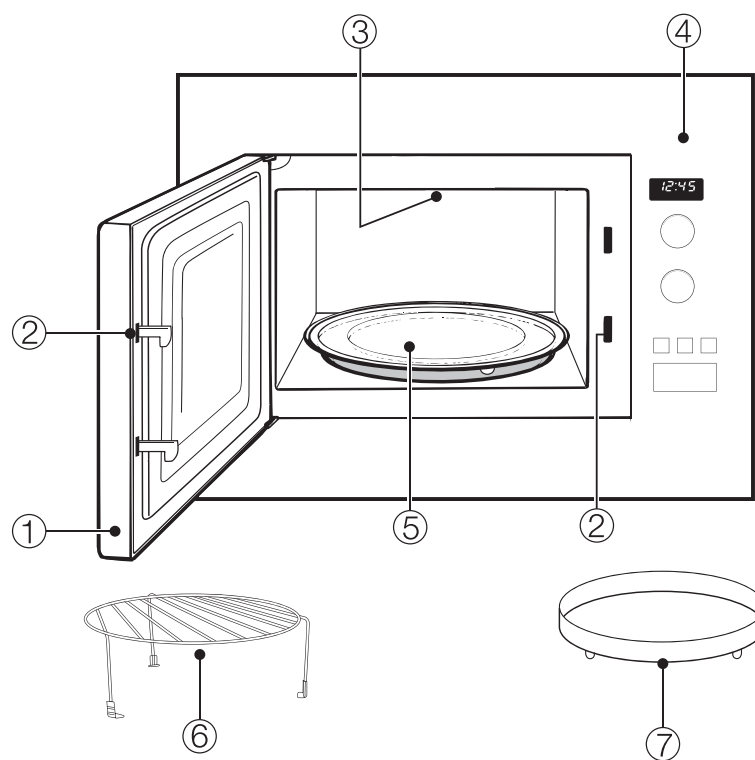

Control Panel

- 8- Display screen
- 9- Time/weight knob
- 10- Function knob
- 11- Auto menu/timer
- 12- Stop/cancel
- 13- Confirm/start
- 14- Door release button

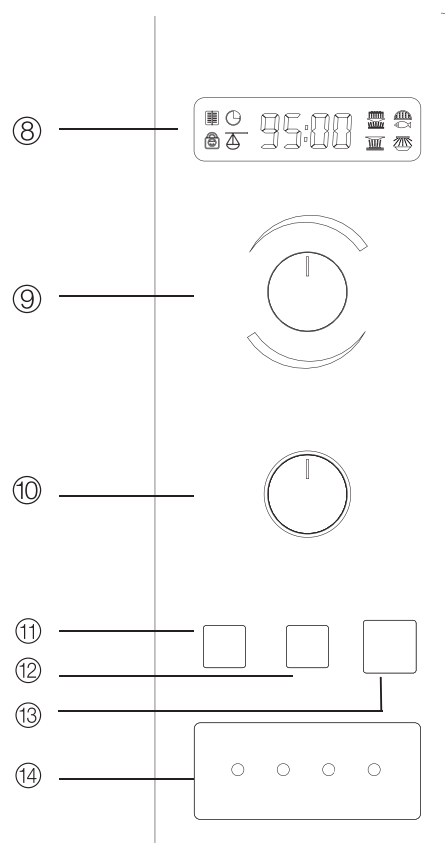

Function Lock

The function lock prevents the function being used by children, for example.

To activate the function lock press button 12 for 3 seconds until the screen display's the below.



To cancel the system lock:

Press button 12 for 3 seconds until the screen display's the below:

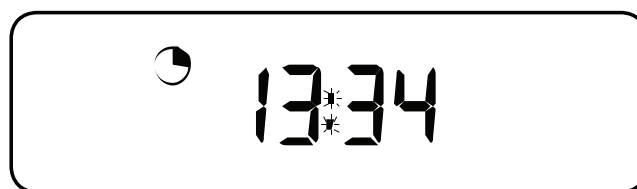

Time Setting

Press button 11 for 3 seconds to adjust the hours by turning knob 9. Press button 11 once again to adjust minutes. Press button 11 once more to confirm time.

Defrost

Turn knob 10 to select 'Defrost' and the screen display P-30, then turn knob 9 to set time from 0:05 to 60:00, and press button 13 to confirm.

Example: If you want to use Defrost for 30 minutes, you can operate the microwave oven as the following steps.

- 1) Turn knob 10 to select 'Defrost' and the screen display P-30.
- 2) Turn knob 9 to set time until displays 30:00
- 3) Press button 13 to confirm.

Microwave Cooking

Turn knob 10 to select microwave power,

Turn	Power	Screen
0	20%	P-20
1	30%	P-30
2	40%	P-40
3	60%	P-60
4	80%	P-80
5	100%	P-H1

Turn knob 9 to select cooking time from 0:05 to 60:00

Press button 13 to confirm and start cooking.

Operation

Note: the step quantities for the adjustment time are as follow:

- 0---1 min: 5 seconds
- 1---3 min: 10 seconds
- 3---10 min: 30 seconds
- 10---30 min: 1 minute
- 30---60 min: 5 minutes

Example: If you want to use 80% microwave power to cook for 30 minutes, you can operate the microwave oven as the following steps.

- 1) Turn knob 10 to select 'M.High' and the screen display P-80.
- 2) Turn knob 9 to set time until displays 30:00
- 3) Press button 13 to confirm and start cooking.

Grill

Turn knob 10 to 'Grill' position, turn knob 9 to set cooking time from 0:05 to 60:00, press button 13 to confirm and start cooking.

Example: If you want to use 'Grill' function to cook for 20 minutes, you can operate the microwave oven as the following steps.

- 1) Turn knob 10 to select 'Grill'
- 2) Turn knob 9 to set time until displays 20:00
- 3) Press button 13 to confirm and start cooking.

IMPORTANT: When using the grill function do not use the quick start button to set the cooking time as this will trigger the microwave function. Operating the microwave function with the grill rack in the unit can cause sparking and potentially irreparable damage.

Warm

Turn knob 10 to 'Warm' position, turn knob 9 to set cooking time from 0:05 to 60:00, press button 13 to confirm and start cooking.

Sterilize

Turn knob 10 to 'Sterilize' position, press button 13 to confirm and start sterilize. The sterilize time is 5 minutes which can't be adjusted.

Warning: the sterilize function is to be used as part of the Microwave's disinfection program. This function is not suitable for metal utensils or anything that has metal or any item that is not of a thermo labile material.

Combination Cooking

Turn knob 10 to 'COMB' position. There are 3 combination programs as below:

COMB 1: (30% micro+70% grill), the screen display CO-1

COMB 2: (55% micro+45% grill), the screen display CO-2

COMB 3: (70% micro+30% grill), the screen display CO-3

Turn knob 9 to set cooking time from 0:05 to 60:00, press button 13 to confirm and start cooking.

Example: If you want to use 55% microwave power and 45% grill power (CO-2) to cook for 10 minutes, you can operate the microwave oven as the following steps.

- 1) Turn knob 10 to select 'COMB 2' and the screen display CO-2
- 2) Turn knob 9 to set time until displays 10:00
- 3) Press button 13 to confirm and start cooking.

IMPORTANT: do not use the grilling rack in microwave or combination grilling modes. Operating the microwave function with the grill rack in the unit can cause sparking and potentially irreparable damage.

Operation

Automatic programmers

Press button 11 to select cooking program according to below table:

Turn knob 9 to select weight, and press button 13 to confirm and start cooking.

No.	AUTO MENU	1	2	3	4	5	6	7	8	9	10
1	RICE	100g	200g	300g	400g	500g					
2	VEGETABLE	100g	200g	300g	400g	500g	600g				
3	MILK/COFFE	1 cup	2 cup	3 cup							
4	POPCORN										
5	POTATO	200g	300g	400g	500g	600g	700g	900g	1100g	1300g	1500g
6	PIZZA	150g	300g	450g							
7	FISH	100g	200g	300g	400g	500g	600g	700g	800g	900g	1000g
8	BREAD	100g	200g	300g	400g	500g					
9	CHICKEN	200g	400g	600g	800g	1000g	1200g	1400g			
10	MEAT	200g	400g	600g	800g	1000g	1200g	1400g			
11	SKEWERED MEAT	200g	300g	400g	500g	600g					

The oven goes to sleep mode with no operation in five minutes.

AUTO MENU	DISPLAY
RICE	A-01
VEGETABLE	A-02
MILK/COFFE	A-03
POPCORN	A-04
POTATO	A-05
PIZZA	A-06
FISH	A-07
BREAD	A-08
CHICKEN	A-09
MEAT	A-10
SKEWERED MEAT	A-11

Cleaning and Care

1. Turn the oven off and remove the power plug from the wall socket before cleaning.
2. Keep the inside of the oven clean. When food splatters or spilled liquids adhere to oven walls, wipe with a damp cloth. The use of harsh detergent or abrasives is not recommended.
3. The outside oven surface should be cleaned with a damp cloth. To prevent damage to the operating parts inside the oven, water should not be allowed to seep into the ventilation openings.
4. Do not allow the Control Panel to become wet. Clean with a soft, damp cloth and mild non-abrasive detergent. Do not use abrasives or spray-on cleaners on the control Panel.
5. If steam accumulates inside or around the outside of the oven door, wipe with a soft cloth. This may occur when the microwave oven is operated under high humidity conditions and in no way indicates malfunction of the unit.
6. It is occasionally necessary to remove the glass tray for cleaning. Wash the tray in warm sudsy water or in a dishwasher.
7. The roller ring and oven cavity floor should be cleaned regularly to avoid excessive noise. Simply wipe the bottom surface of the oven with mild detergent, water or window cleaner and dry. The roller ring may be washed in mild sudsy water or dish washer. Cooking vapour collect during repeated use but in no way affect the bottom surface or roller ring wheels. When removing the roller ring from cavity floor for cleaning, be sure to replace it in the proper position.
8. Remove odors from your oven by combining a cup of water with the juice and skin of one lemon in a deep microwaveable bowl. Microwave for 5 minutes, wipe thoroughly and dry with a soft cloth.
9. When it becomes necessary to replace the oven light, please consult a dealer to have it replaced.

Installation

When installing the appliance, ensure that the vent outlets at the front of the appliance are not hindered, and that there is adequate ventilation to the rear of the housing unit by leaving a large enough gap (see diagram: 50 mm x unit width). Do not block the ventilation gaps with any objects. The appliance is designed to be built into a tall unit. To transport the appliance, make sure that you lift it by the appliance housing and not by the frame. The frame is not sturdy enough to bear the weight of the appliance when it is being carried. Building-in dimensions:

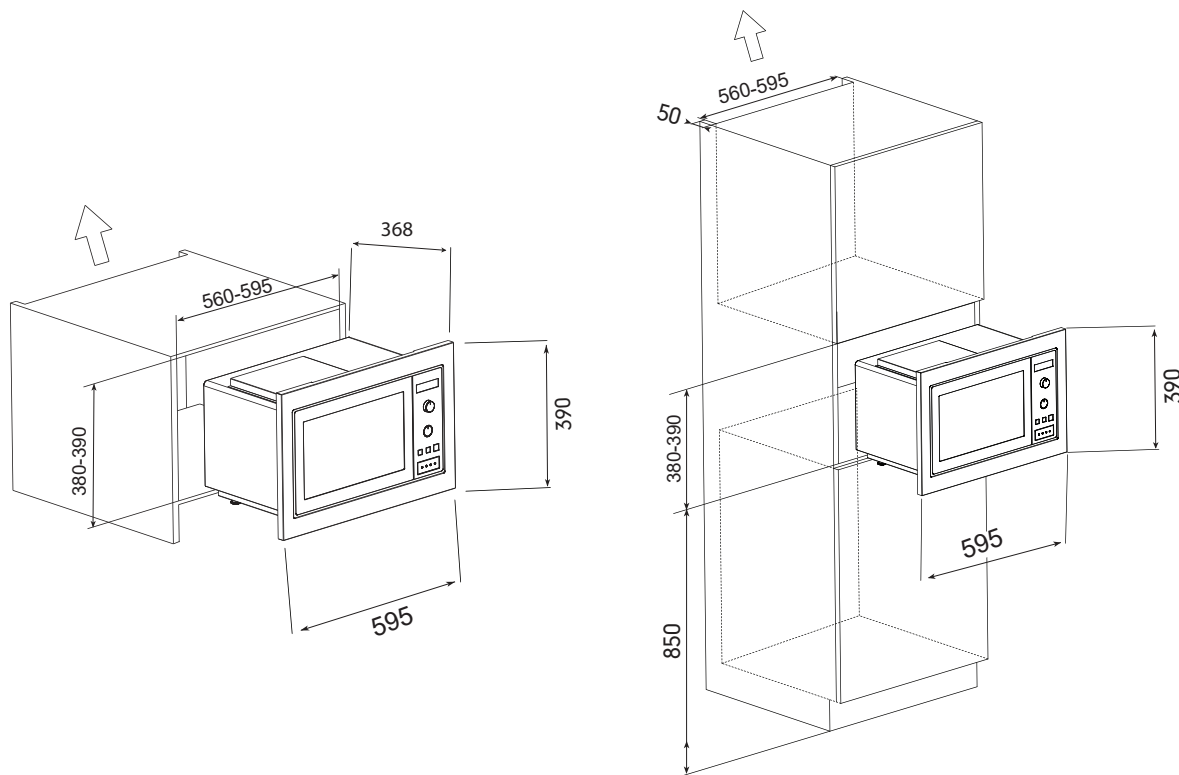

The appliance must be built in before it can be used. Otherwise it poses an electric shock hazard.

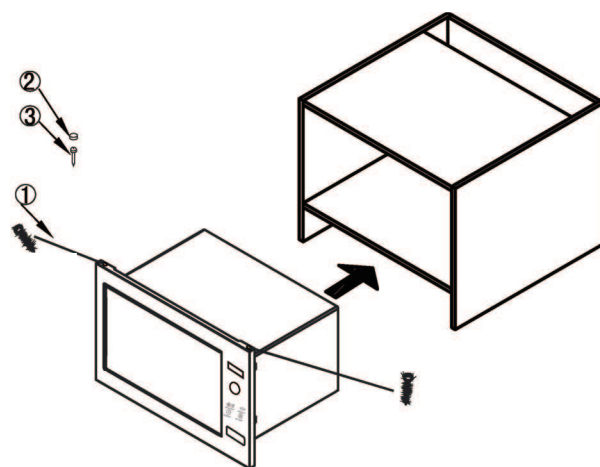

COMPONENTS

- | | | |
|--------------|------------------------------|------|
| 1、bolt | $\phi 3 \times 20 \text{mm}$ | 2PCS |
| 2、screwcover | | 1PCS |
| 3、bolt | $\phi 4 \times 35 \text{mm}$ | 1PCS |

FRAME INSTALLATION STEPS

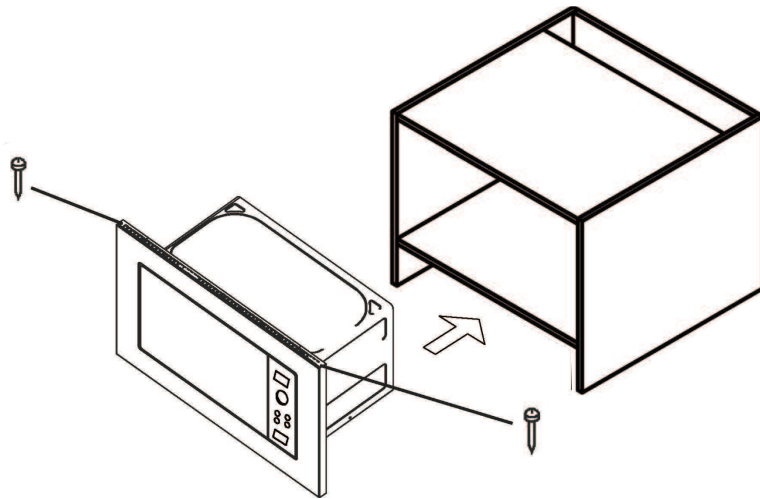

1. Put the microwave oven into the cabinet and keep the microwave oven in a horizontal direction and keep the edge distance of two side as same. Then fix the bolt (component 1) on the top of microwave oven and beat it into the cabinet.

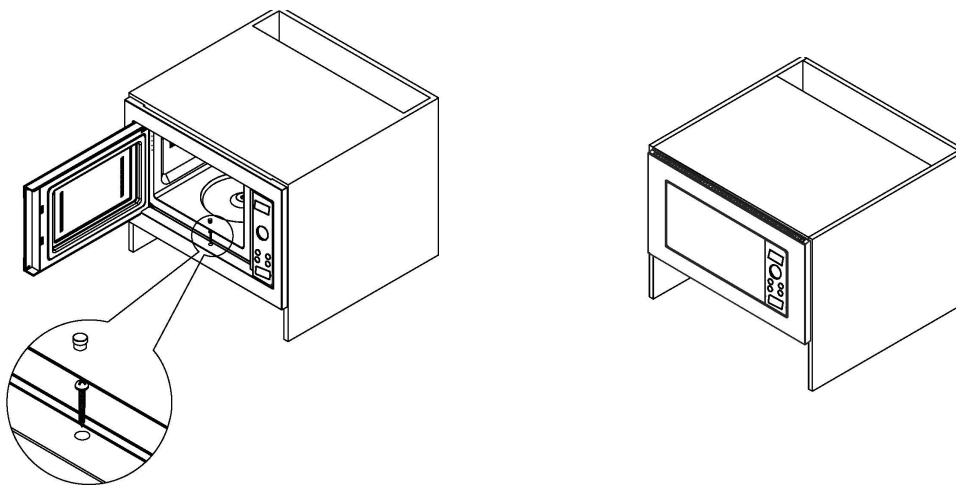

2. Open the microwave oven, fix the bolt (Component 3) and beat it into the cabinet, then install screw cover

EUROLINX LIMITED WARRANTY



Eurolinx Pty Limited A.B.N. 50 001 473 347
Office: 48-50 Moore Street, Leichhardt N.S.W 2040
Post: Locked Bag 3000, Annandale, N.S.W 2038
P: 1300 694 583

WARRANTY REGISTRATION

Your ongoing satisfaction with your product is important to us. We ask that you complete the enclosed Warranty Registration Card and return it to us so that we have a record of the products you purchased. Alternatively you can register on line (see registration card for details)

PRIVACY

We respect your privacy and is committed to handling your personal information in accordance with the National Privacy Principles and the Privacy Act 1988 (Cth). A copy of the Privacy Policy is available at www.eurolinx.com.au. Eurolinx will not disclose any personal information set out in the Warranty Registration Card ("Personal Information") without your consent unless required by:

1. law;
2. any Eurolinx related company;
3. any service provider which provide services to Eurolinx or assist Eurolinx in providing services (including repair and warranty services) to customers. Our purpose in collecting the Personal Information is to keep a record of the Eurolinx product purchased by you, in order to provide a better warranty service to you in the unlikely event that there is a problem with your Eurolinx product. Eurolinx may contact you at any one or more of the address, email address or telephone numbers set out in the Warranty Registration Card. Please contact Eurolinx on 1300 694 583 should you not wish to be contacted by Eurolinx.

WARRANTY

1. Warranty

Eurolinx warrants that each Eurolinx product will remain, for a period of twenty four (24) months computed from the date of purchase of the Eurolinx product, free from defects arising in the manufacture of the Eurolinx product ("Warranty"). Except for consumer guarantees set out in the Competition and Consumer Act 2010 (Cth) ("Act"), Eurolinx does not make any further warranties or representations in relation to Eurolinx products.

2. What is not Covered by the Warranty.

The Warranty does not apply if an Eurolinx product is defective by a factor other than a defect arising in the manufacture of the Eurolinx product, including but not limited to:

- (a) damage through misuse (including failure to maintain, service or use with proper care), neglect, accident or ordinary wear and tear (including deterioration of parts and accessories and glass breakage);
- (b) use for purpose for which the Eurolinx product was not sold or designed;
- (c) use or installation which is not in accordance with any specified instructions for use or installation;
- (d) use or operation after a defect has occurred or been discovered;
- (e) damage through freight, transportation or handling in transit (other than when Eurolinx is responsible);
- (f) damage through exposure to chemicals, dusts, residues, excessive voltage, heat, atmospheric conditions or other forces or environmental factors outside the control of Eurolinx;
- (g) repair, modification or tampering by the purchaser or any person other than Eurolinx, an employee of Eurolinx or an authorised Eurolinx service contractor;
- (h) use of parts, components or accessories which have not been supplied or specifically approved by Eurolinx.
- (i) damage to surface coatings caused by cleaning or maintenance using products not recommended in the Eurolinx product handbook provided to the purchaser upon purchase of the Eurolinx product;
- (j) damage to the base of an electric oven due to items having been placed on the base of the oven cavity or covering the base, such as aluminium foil (this impedes the transfer of heat from the element to the oven cavity and can result in irreparable damage); or
- (k) damages, dents or other cosmetic imperfections not affecting the performance of the Eurolinx in respect of an Eurolinx product purchased as a "factory second" or from display. The Warranty does not extend to light globes used in Eurolinx products.

3. Domestic Use

Each Eurolinx product is made for domestic use. This Warranty may not extend to Eurolinx products used for commercial purposes; under those circumstances the warranty period is limited to 3 month.

4. Time for Claim under the Warranty

You must make any claim under this Warranty within twenty eight (28) days after the occurrence of an event which gives rise to a claim pursuant to the Warranty, by booking a service call on the telephone number below.

5. Proof of Purchase

Customers must retain proof of purchase in order to be eligible to make a warranty claim in respect of an Eurolinx product.

Continued over...

EUROLINX LIMITED WARRANTY



6. Claiming under the Warranty

Customers will bear the cost of claiming under this Warranty unless Eurolinx determines the expenses are reasonable, in which case the customer must claim those expenses by providing written evidence of each expense to Eurolinx at the address on the Warranty Registration Card.

7. Statutory Rights

- (a) These terms and conditions do not affect your statutory rights.
- (b) The limitations on the Warranty set out in this document do not exclude or limit the application of the consumer guarantees set out in the Act or any other equivalent or corresponding legislation in the relevant jurisdiction where to do so would:
- (i) contravene the law of the relevant jurisdiction; or
 - (ii) cause any part of the Warranty to be void.
- (c) Eurolinx excludes indirect or consequential loss of any kind (including, without limitation, loss of use of the Eurolinx product) and (other than expressly provided for in these terms and conditions) subject to all terms, conditions and warranties implied by custom, the general law, the Act or other statute.
- (d) The liability of Eurolinx to you for a breach of any express or non-excludable implied term, condition or warranty is limited at the option of Eurolinx to:
- (i) replacing or repairing the defective part of the Eurolinx product;
 - (ii) paying the cost of replacing or repairing the defective part of the Eurolinx product;
 - (iii) replacing the Eurolinx product; or
 - (iv) paying the cost of replacing the Eurolinx product.
- (e) Our goods come with guarantees that cannot be excluded under the Australian Consumer Law.

You are entitled to a replacement or refund for a major failure and for compensation for any other reasonably foreseeable loss or damage. You are also entitled to have the goods repaired or replaced if the goods fail to be of acceptable quality and the failure does not amount to a major failure.

8. Defects

Any part of an Eurolinx product deemed to be defective and replaced by Eurolinx is the property of Eurolinx. Eurolinx reserves the right to inspect and test Eurolinx products in order to determine the extent of any defect and the validity of a claim under the Warranty.

*To locate your closest Eurolinx authorised service agent please contact Eurolinx on 1300 694 583, customercare@eurolinx.com.au or visit <http://support.eurolinx.com.au>

IMPORTANT!

All warranty service calls must be booked via the customer care department. The team can be contacted on 1 300 85 64 11 option 1 or customercare@eurolinx.com.au

Service is delivered through a network of Service Agents. If the Appliance is located outside our normal Service Area of our agents you, the Customer will need to bear the cost of travel outside that area.

If you are unable to provide proof of purchase, the fault is not covered under warranty or the product is found to be working to specification you may be required to bear the full cost of the service visit

12062019

WARRANTY REGISTRATION CARD 12062019

Please complete and send to Eurolinx at:

REPLY PAID 83617
LEICHHARDT NSW
2040

Last Name:		First Name:	
Address:			
State:	Postcode:	Email:	
Home Phone:		Mobile:	
Purchase Date: / /		<i>(Please attach proof of purchase to validate warranty)</i>	

MODEL NUMBER	SERIAL NUMBER <i>(if you cannot locate the serial number please call Eurolinx on 1300 85 64 11)</i>
1	
2	
3	
4	

Notes

You can now find us on:



facebook.com/ILVEappliances



twitter.com/#!/ILVE_appliances



youtube.com/user/ILVEappliances



livewithilve.com



Australia National Telephone Number 1300 MYILVE (694 583)
New Zealand Telephone Number 0508 458 369

ILVE showrooms are open daily from 9am-5pm and Saturdays 10am-4pm
(WA by appointment only on Saturdays)

ilve.com.au

NSW & ACT (Head Office)
48-50 Moorabie Street
Leichhardt
F 02 8569 4699

VIC, TAS & SA
1211 Toorak Road
Camberwell
F 03 9809 2155

QLD
1/42 Cavendish Road Coorparoo
F 07 3397 0850

WA & NT
Unit 10/55 Howe Street
Osborne Park
F 08 9201 9188

New Zealand
PO Box 11.160
Sockburn Christchurch
F 03 344 5906

V20211130