

Congratulations on your new ThermoPro product. To ensure the best possible product performance, please read this manual in its entirety and retain it for future reference.

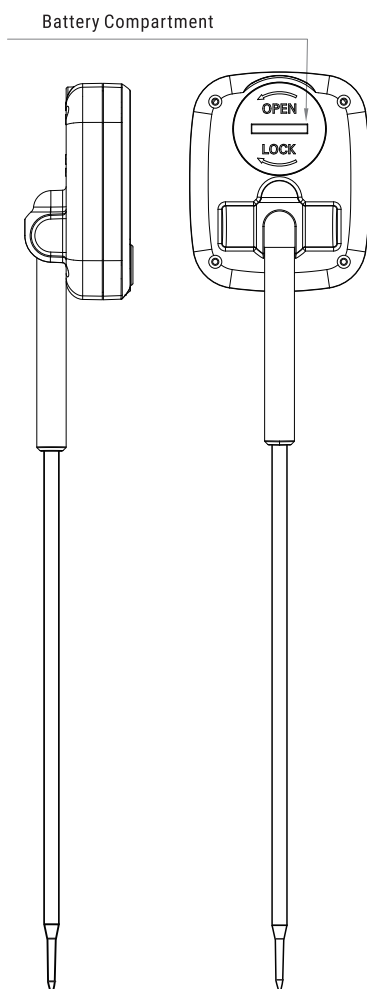
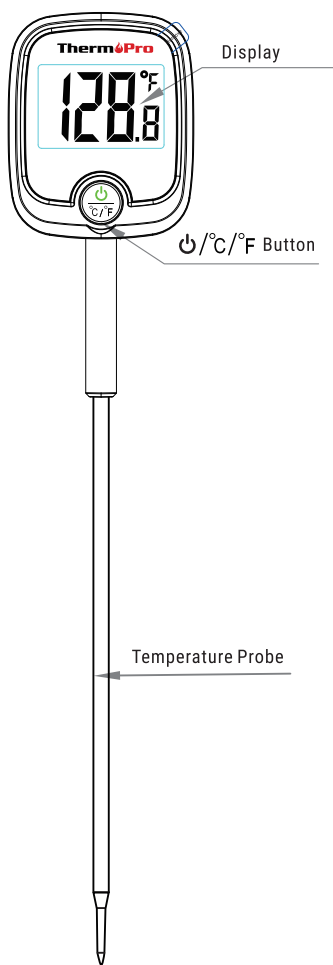
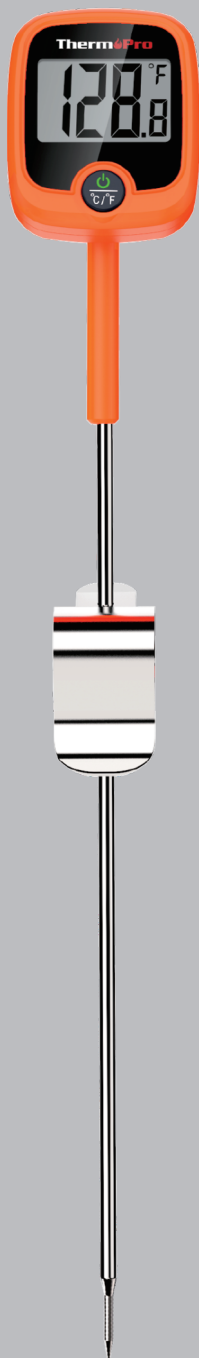

1. Features

1. Display: Displays the temperature measured by the probe instantly.
2. Food Grade Probe: Insert probe into the liquid to receive the temperature within 5 seconds.
3. IPX5 Grade Waterproof: Can be washed under running water without fear!
4. Auto-off: Turns off automatically after 2 hours if no button has been pressed and the temperature has been lower than 50°C ±3°C (122°F ±5°F).
5. Stainless Steel Pot Clip.
6. 8.12" Stainless Steel Probe: Long probe will accommodate any size of pot.
7. Temperature Range: -58°F~572°F (-50°C~300°C). If the temperature is below -58°F (-50°C) or above 572°F (300°C), LL.L or HH.H will show on the display.
8. Resolution: 0.1°C/°F
9. Temperature Accuracy: ±0.9°F (±0.5°C) in range between 32°F~212°F (0~100°C)
10. Power: 1 x LR44 Battery (1.5V)

2. Components

- 1 x Candy Thermometer
- 1 x Stainless Steel Clip
- 1 x Silicone Cap
- 1 x LR44 Battery
- 1 x User Manual

3. Button

- ⏻/°C/°F: Press once to turn ON/OFF the unit. Press and hold for 3 seconds to select temperature display unit in °C or °F.

4. Before First Use

1. Insert or Replace Battery: Insert 1 x LR44 battery in correct polarity (+) and (-) as indicated. Please make sure the battery cover is tightened securely.
2. Clean Stainless Tip: wash tip with warm soapy sponge or cloth, then rinse and dry.
3. PLEASE READ AND FOLLOW ALL INSTRUCTIONS.
4. The thermometer is now ready to use.

5. To Measure Food Temperature



1. Press ⏻/°C/°F button to turn on the thermometer.
2. Press and hold ⏻/°C/°F button for 3 seconds to select temperature display unit in °C or °F. Please note that the last selected temperature unit will be saved for next use.
3. Insert the tip of probe into food/liquid that you intend to measure. The thermometer will start to measure the internal oil/syrup temperature, wait until temperature reading stabilizes on the display.
4. Press ⏻/°C/°F button once to turn off the thermometer. The device will automatically turn off after 2 hours of inactivity and the temperature has been below 122°F(50°C).

6. Helpful Hints

- When measuring multiple or different foods and meats, it may be desirable to cool the probe by rinsing the tip with cold water between readings.
- It is recommended that you wipe the probe tip clean between readings.
- Do not leave the whole product in an oven, because it may damage electronic and plastic parts.
- Not intended for use by people aged 12 or under.

DIGITAL CANDY & FRYING THERMOMETER

INSTRUCTION MANUAL

 WARNING	
KEEP OUT OF REACH OF CHILDREN Swallowing can lead to chemical burns, perforation of soft tissue, and death. Severe burns can occur within 2 hours of ingestion. Seek medical attention immediately.	

7. Care of Your Thermometer

- Do not touch the stainless portion of the thermometer during or right after measuring temperatures since it will be hot.
- Do not leave exposed to temperatures higher or lower than the measurement range(58°F~572°F) as this will damage electronic parts and plastics.
- Do not place the whole product in dishwasher or immerse in any liquid. Clean under running water or wipe the probe tip with a damp soapy cloth or sponge and then dry.
- Remove battery if stored for more than four months.
- Do not dispose this unit in a fire. IT MAY EXPLODE.
- Keep unit away from children. The unit or parts of the unit might be a choking hazard.
- Dispose of the unit legally and recycle when possible.

8. Declaration of Conformity

Hereby, the manufacturer declares that this product complies with the basic requirements and applicable regulations of

the EMC Directive 2014/30/EU. The complete declaration of conformity can be found at:
<https://buythermopro.com/eu-declaration-of-conformity/>.

9. Disposal of the Electronic Appliance



This electronic appliance should not be disposed of with normal household waste. Dispose of the unit at an approved facility or at your local recycling center. Please

observe the current rules and regulations when disposing of the appliance. Contact your local council if in doubt.

10. Limited One-Year Warranty

ThermoPro warrants this product to be free of defects in parts, materials and workmanship for a period of one year, from date of purchase.

Should any repairs or servicing under this warranty be required, contact Customer Service by phone or email for instructions on how to pack and ship the product to ThermoPro.

This warranty gives you specific legal rights and you may also have other rights which vary from state to state.

11. Customer Service

Call or Tex: 1-877-515-7797
 (USA & Canada only)

Email: service@buythermopro.com

Hours: Weekdays 9:00AM-5:00PM EST

Our website: www.buythermopro.com

Specification

Temperature Range	-58.0 to 572°F(-50.0 to 300.0°C)
Tolerance	±0.9°F(±0.5°C) from 32 to 212°F(0 to 100°C), otherwise ±1.5%
Response Time *	5 seconds
Sensor Type	NTC
Probe	304 Stainless Steel, 8 ¹ / ₈ inches (205mm)
Display	LCD, 1 ⁷ / ₁₆ Length x 1 ¹ / ₁₆ Width inches(36.6L x 27.1W mm)
Unit Size	1 ⁷ / ₈ Length x 1 ¹ / ₆ Width x 12Height inches(48.5 L x 29.5 W x306.0H mm)
Power	1.5V (1 x LR44 button battery)

*Response Time defined as the time it takes for Thermopro thermometers to read from ambient temperature (77°F or 25°C) to within 1.8°F (1°C) of final temperature of an object (150°F or 65°C). 150°F (65°C) is the recommended minimum temperature for many types of meat.