

Thinking of you

 **Electrolux**



FAN ASSIST BAKE
Fast heat up

ON/OFF

function



user manual
e:line built in ovens

(EOEM61AS, EOEE62AS,
EOEE63AS, EUUE63AS, EDEE63AS,
EPEE63AS, EOEK62AK)

app
Ar



er

Congratulations

Congratulations and thank you for choosing our built in oven. We are sure you will find your new oven a pleasure to use. Before you use the oven, we recommend that you read through the whole user manual, which provides the description of the built in oven and its functions. To avoid the risks that are always present when you use an electric appliance, it is important that the oven is installed correctly and that you read the safety instructions carefully to avoid misuse and hazards.

We recommend that you keep this user manual for future reference and pass it on to any future owners.

After unpacking the built in oven please check it is not damaged. If in doubt, do not use the appliance but contact your local Electrolux Customer Care Centre.

Contents

• Important safety instructions	3
• Rotary control oven	4
• Electronic control oven	4
• Electronic touch control oven	4
• Rotary control panel	5
• Electronic control panel	5
• Electronic touch control panel	5
• Before using your rotary control oven	6
• Cooking functions – rotary control oven	7
• Operating sequence – rotary control oven	8
• Cooking with the timer – rotary control oven	9
• Before using your electronic control oven	10
• Cooking functions – electronic oven & touch control	12
• Operating sequence – electronic control oven	14
• Cooking with the timer – electronic control oven	15
• Additional functionality – electronic control oven	16
• Operating sequence – EOEK62AK	17
• Cooking with the timer – EOEK62AK	18
• Additional functionality – EOEK62AK	19
• Cooking guide	20
• Grilling guide	22
• Dealing with cooking problems	23
• Maintenance and cleaning	24
• Cleaning your accessories	24
• Replacing the top oven light – EPEE63AS	25
• Catalytic self cleaning panels	26
• Pyrolytic cleaning of the oven cavity – EPEE63AS	27
• Cleaning the pyrolytic oven door	28
• Cleaning the pyrolytic oven	29
• Troubleshooting	30
• Installation	31
• Technical specifications	33
• Hard wiring details	34
• Warranty	35



environmental tip

Information on disposal for users

- Most of the packing materials are recyclable. Please dispose of those materials through your local recycling depot or by placing them in appropriate collection containers.
- If you wish to discard this product, please contact your local authorities and ask for the correct method of disposal.



Important safety instructions

These warnings have been provided in the interest of safety. You **MUST** read them carefully before installing or using the appliance.

The symbols you will see in this booklet have these meanings:



warning

This symbol indicates information concerning your personal safety



tips and information

This symbol indicates tips and information about use of the oven



environmental tip

This symbol indicates tips and information about economical and ecological use of the oven

Installation, cleaning and servicing

- An authorised person must install this appliance. (Certificate of Compliance to be retained)
- Before using the appliance, ensure that all packing materials are removed from the appliance.
- In order to avoid any potential hazard, the enclosed installation instructions must be followed.
- Ensure that all specified vents, openings and air spaces are not blocked.
- Where the appliance is built into a cabinet, the cabinet material must be capable of withstanding 70°C. If adjacent to vinyl-wrapped surfaces, use installation kit from vinyl wrap supplier.
- Only authorised personnel should carry out servicing. (Certificate of Compliance to be retained)
- Always ensure the appliance is switched off before cleaning or replacing parts.
- Do not use steam cleaners, as this may cause moisture build-up.
- Always clean the appliance immediately after any food spills.
- **This appliance must be earthed.**



warning

Child safety

- This appliance is not intended for use by persons (including children) with reduced physical, sensory or mental capabilities, or lack of experience and knowledge, unless they have been given supervision or instruction concerning use of the appliance by a person responsible for their safety.
- Children should be supervised to ensure that they do not play with the appliance.
- During use this appliance becomes hot. Care should be taken to avoid touching hot surfaces, e.g. oven door, heating elements.
- Accessible parts will also become hot when in use. To avoid burns and scalds children should be kept away.



warning

General warnings

- This appliance must not be used as a space heater.
- In order to avoid fire, the appliance must be kept clean and vents kept unobstructed.
- Do not spray aerosols within the vicinity of the appliance during operation.
- Do not store flammable materials in or under the appliance, e.g. aerosols.
- Do not line the bottom of the oven with foil or cookware.
- Always use gloves when handling hot items inside the oven.
- Always turn the grill off immediately after use as fat left behind may catch fire.

Grill

- Do not cover the grill insert with foil, as fat left there may catch fire.
- Always keep the grill dish clean as any fat there may catch fire.
- Do not leave the grill on unattended.
- To avoid fire, ensure that grill trays and fittings are always inserted into the appliance in accordance with the instructions.
- Do not place thick portions of food under the grill. Foods may curl, catch and ignite.
- Accessible parts may become hot when grill is in use. Children should be kept away.

Oven

- During use the appliance becomes hot. Care should be taken to avoid touching the hot surfaces inside the oven.
- Switch the appliance off before removing the oven light glass for globe replacement.
- To avoid an accident, ensure that oven shelves and fittings are always inserted into the appliance in accordance with the instructions.
- Do not use the door as a shelf.
- Do not push down on the open oven door.



warning

To maintain safe operation, it is recommended that the product be inspected every five years by an authorised service person.



environmental tip

To save energy and to help protect the environment, we recommend these hints:

- Use the oven efficiently, by cooking many trays of food at the same time.
 - Cook 2 trays of scones, small cakes or sausage rolls at the same time.
- Select the correct shelf location for food being cooked.
- Do not open the oven door more than necessary.
- After the oven is turned off it retains heat for some time. Use this heat to finish custards or to dry bread.
- Use the smaller oven cavity (if you have an EUFF63AS) in preference to the main oven cavity.

Rotary control ovens

(EOEM61AS)

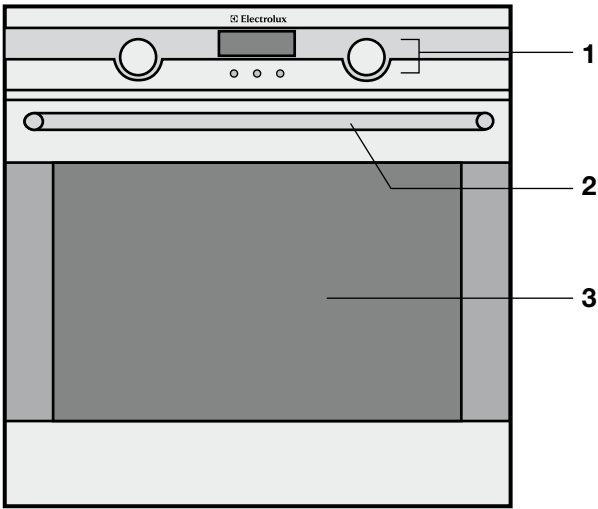

- 1 Rotary control panel
- 2 Oven handle
- 3 Oven door

Electronic control ovens

(EOEE62AS, EOEE63AS, EU EE63AS, EDEE63AS, EPEE63AS)

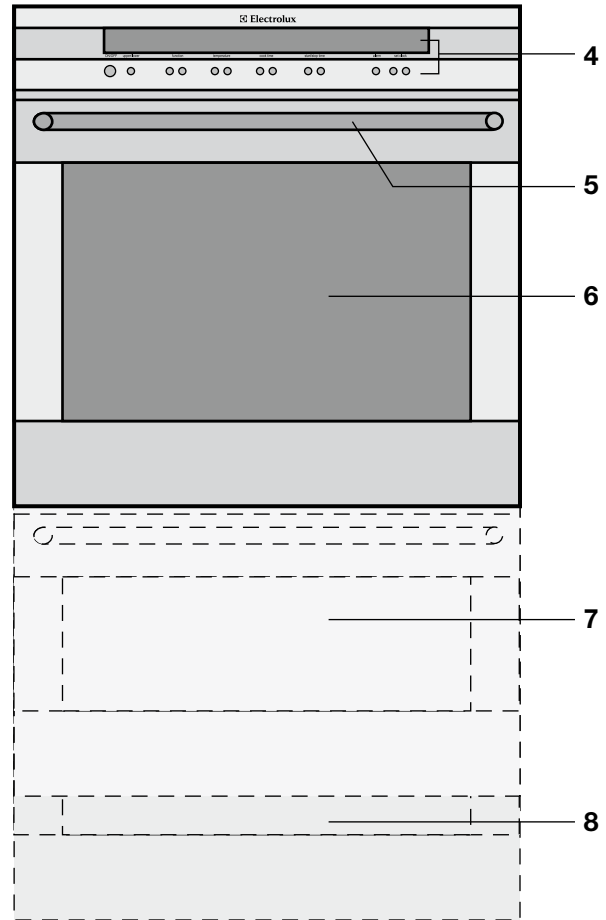

- 4 Electronic control panel
- 5 Oven handle
- 6 Oven door
- 7 Duo oven (EU EE63AS Only)
- 8 Double oven (EDEE63AS Only)

Electronic touch control ovens

(EOEK62AK)

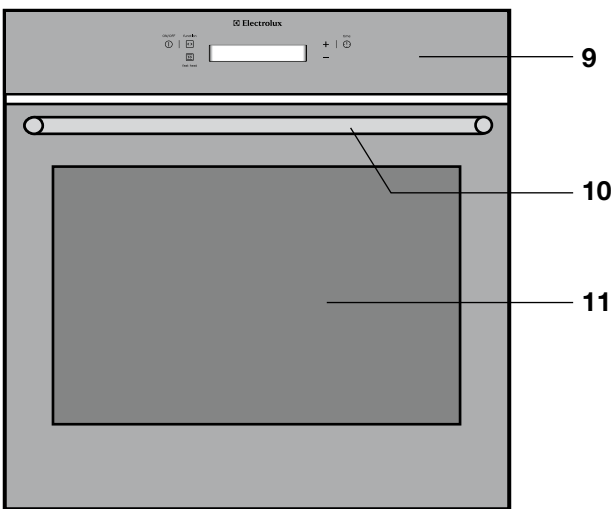

- 9 Electronic touch control panel
- 10 Oven handle
- 11 Oven door

Rotary control panel (EOEM61AS)

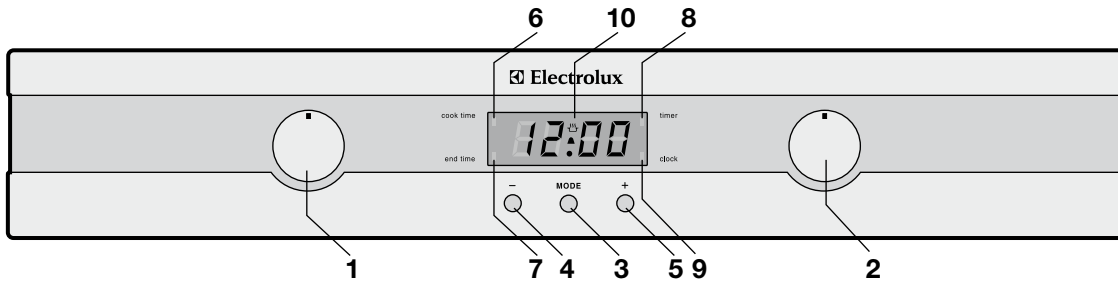

- | | | |
|-----------------------------------|-----------------------|-------------------|
| 1 Oven function selector | 5 Increase time | 9 Clock indicator |
| 2 Oven/grill temperature selector | 6 Cook time indicator | 10 Display |
| 3 Mode selector | 7 End time indicator | |
| 4 Decrease time | 8 Timer indicator | |

Electronic control panel (EOEE62AS, EOEE63AS, EUUE63AS, EDEE63AS)

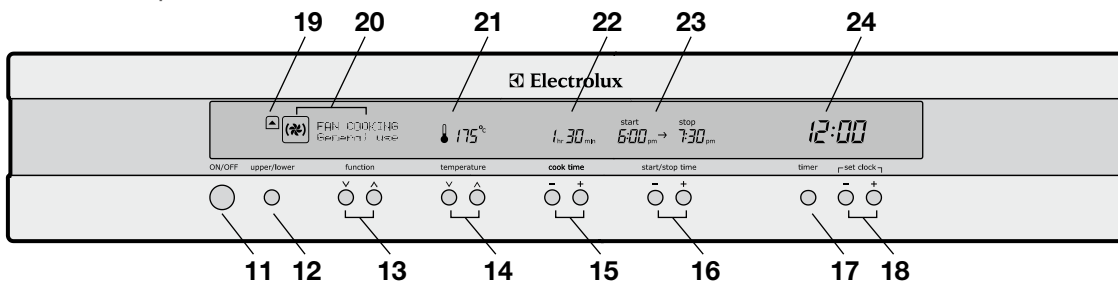

- | | | |
|------------------------------------------------------------|--------------------------------|-----------------------------|
| 11 ON/OFF button | 15 Cook time selectors | 20 Cooking function display |
| 12 Upper/lower oven selector
(EUUE63AS & EDEE63AS only) | 16 Start/stop time selectors | 21 Temperature display |
| 13 Cooking function selectors | 17 Timer button | 22 Cook time display |
| 14 Temperature selectors | 18 Set clock buttons | 23 Start/stop time display |
| | 19 Upper or lower oven display | 24 Clock |

Electronic control panel (EPEE63AS)

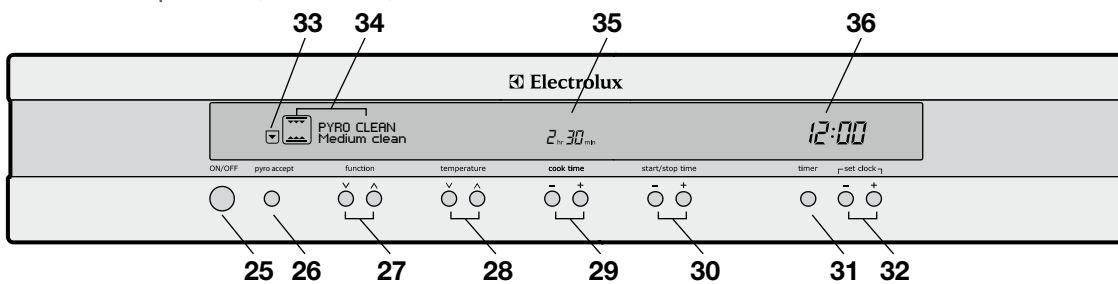

- | | | |
|-------------------------------|---------------------------------|-----------------------------|
| 25 ON/OFF button | 29 Cook/Pyroclean time selector | 33 Pyro accept indicator |
| 26 Pyro accept button | 30 Start/stop time selectors | 34 Cooking function display |
| 27 Cooking function selectors | 31 Timer button | 35 Cook time display |
| 28 Temperature selectors | 32 Set clock buttons | 36 Clock |

Electronic touch control panel (EOEK62AK)

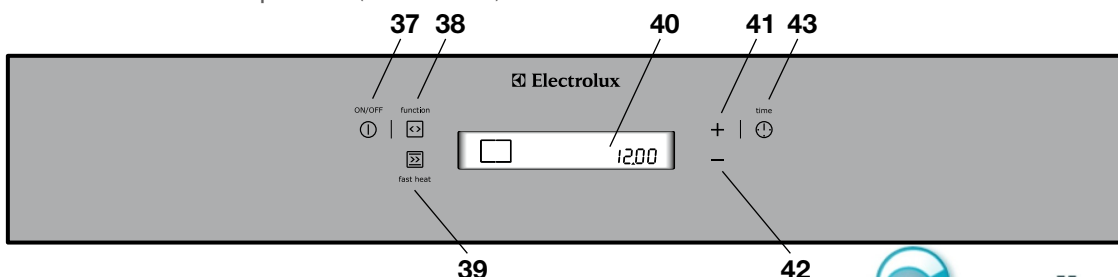

- | | | |
|------------------------------|------------------------------|------------------------|
| 37 ON/OFF function | 40 Display | 43 Clock/Time function |
| 38 Cooking function selector | 41 Add time/temperature | |
| 39 Fast Heat up function | 42 Subtract time/temperature | |

Before using your rotary control oven

Preparing your oven

1. Please remove all stickers, leaflets and boxes from the door and from the floor of the oven before operation.
2. Please wipe out the oven interior prior to operation with warm soapy water and polish dry with a soft clean cloth. Do not close the oven door until the oven is completely dry.

Setting the time

After electrically connecting the appliance, you must set the time of day before you can operate your oven.

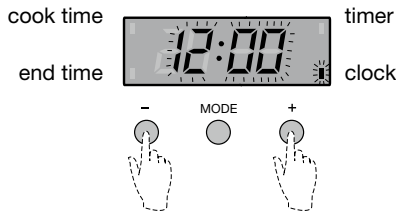

- After the appliance has been electrically connected '12:00' will be displayed and the clock 'indicator' will flash.
- To set the time of day in hours and minutes press the **-** or **+** buttons.

5 seconds after the last change, the clock 'indicator' will disappear, confirming the time has been set. Once the time has been entered, the clock advances minute by minute.

Note:

- The clock has a 24 hour display.

tips and information

New appliances can have a smell during first use. It is recommended to 'run in' the oven before you cook for the first time. Operate the oven, empty, at a temperature of 180°C for approximately 2-4 hours (see page 8 for operating sequence). Please ensure the room is well ventilated during this process.

Installing your oven accessories

• Catalytic liners

The oven will already be fitted with a catalytic fan baffle and top panel. We have supplied side panels for you to fit. They can be fitted before you put the side racks on but you can omit them, if you wish, with no effect to cooking performance. Their sole purpose is to make oven cleaning easier. Of course, you can add them at any time by removing the side racks (see page 24). The catalytic liners will attach to each side of the oven. There will be a left hand and a right hand version.

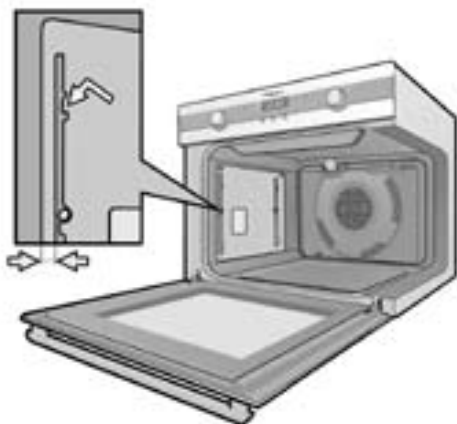

1. Position the first liner as per the diagram. The black, shiny side of the liner should be facing the oven wall, the hooks pointing down and the front edge will have a narrow strip before the vertical slot (when compared to the strip at the rear edge). Note that the diagram shows the left hand liner. The right hand side will be a mirror image of this.
2. Line the hooks up with the slots provided in the oven wall, push them in and then allow the liner to slide down to its final position. All 4 hooks **MUST** be engaged in slots.
3. The access hole for the side racks should be visible when the liner is correctly positioned – see diagram.

• Side racks and telescopic slides

1. Insert the largest peg into the rear access hole provided.
2. Then locate the front peg into the front access hole and push in firmly.

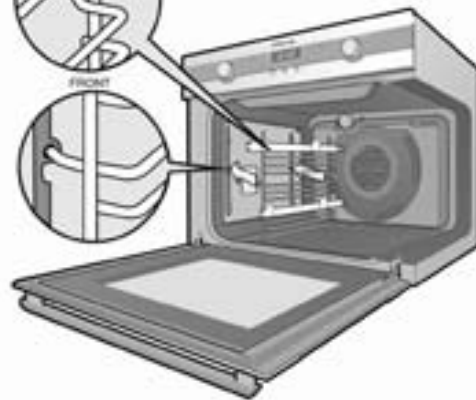
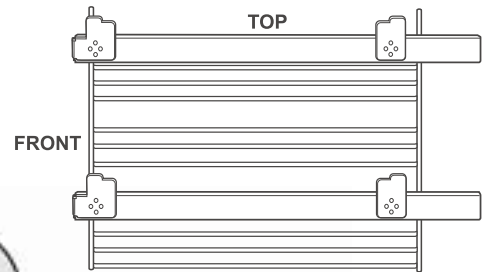

Note:

- If you have purchased an EUEE63AS you will have additional 'fixed' runners for the compact oven. These are fitted in the same manner.

• Shelves and trays

The shelves are designed so that they have maximum extension but cannot be accidentally pulled right out. The trays are designed the same way and slot straight into the side racks.

To fit a shelf or tray to side racks:

1. Locate the rear edge of the shelf/tray in between 2 guide rails of the side rack – see diagram. Ensure the same rail positions on both sides of the oven are being engaged.
2. With the front edge raised, begin to slide the shelf into the oven.
3. Once the detents have passed the front edge of the side rack, the shelf can be pushed completely in.

Cooking functions – rotary control oven

When fully inserted the shelf/tray should not interfere with the closed oven door.

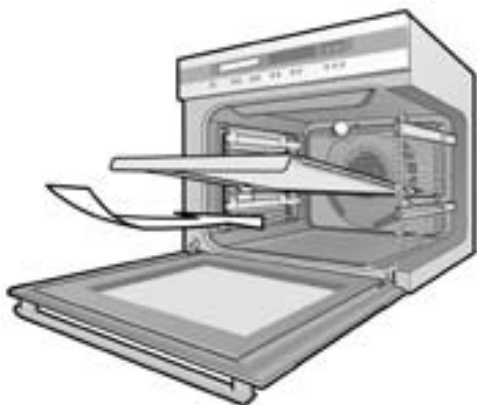

To fit a tray to telescopic slides:

1. Fully extend the slides on both sides.
2. Select the tray you wish to use and position the slots on one side on the respective tabs of the slide.
3. Drop the other side down so that the tray is fully seated on both slides.

When fully inserted the shelf/tray should not interfere with the closed oven door.

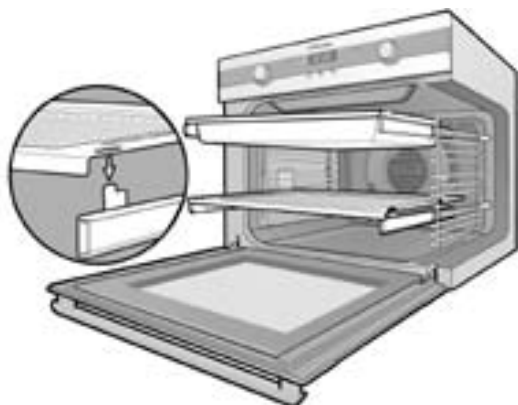







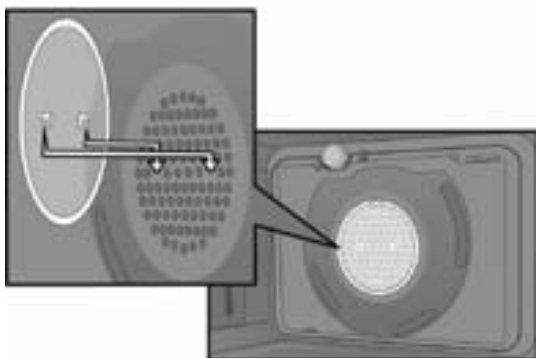

• Fat filter

The fat filter is designed to go onto the front of the fan cover at the rear of the oven. When fully engaged the filter will be positioned in the centre of the fan cover.

1. Locate the mounting slots in the fan cover and the corresponding tags on the fat filter.
2. Position the fat filter onto the fan cover with the tags pointing down.
3. Push the fat filter down into position.



function	description
Rapid heat 	Heat comes from the element surrounding the fan as well as the smaller element above the food. This allows you to preheat your oven 30% quicker than on standard 'Bake'. 'Rapid Heat' is ideal for cooking frozen pre-cooked foods such as savoury pastries, pizzas, mini meals (TV dinners), meat pies and fruit pies. Simply place the food in the oven straight from the freezer and heat. Cook in the upper half of the oven for best results.
Fan cook 	Heat comes from the element surrounding the fan. This fan circulates the hot air around the oven cavity so that you can put your food in different places in the oven and still cook them at the same time. You can use 'Fan cook' function for multi-shelf cooking, reheating cooked foods, pastries and complete oven meals. It will cook at a lower temperature and be faster than baking. Please note that some variation in browning is normal.
Bake/pizza 	Heat comes from two elements, one above and one below the food. The bottom element is a clean heat element and is below the floor of the oven. Both elements are controlled by the thermostat and will turn on and off to maintain set temperature. You can use the 'Bake/pizza' function for single trays of biscuits, scones, muffins, cakes, slices, casseroles, baked puddings, roasts and delicate egg dishes.
Pastry 	Heat comes from the clean heat element below the food. The element is controlled by the thermostat and will turn on and off to maintain the set temperature. The 'Pastry' function can be used to add extra browning to the bases of pizzas, pies, and pastries. Cook in the lower half of the oven when you are using only one shelf.
Defrost 	The 'Defrost' function uses low temperature air that is circulated by the fan. You can defrost (thaw) your food before you cook it. You can also use 'Defrost' to raise your yeast dough and to dry fruit, vegetables and herbs.
Fan grill 	'Fan Grill' offers you the benefits of both 'Bake' and traditional 'Grill' functions. The grill element turns on and off to maintain set temperature while the fan circulates the heated air. The oven door remains closed for fan grill. You can use 'Fan Grill' for large cuts of meat, which gives you a result that is similar to 'roisserie' cooked meat. Put your food on a shelf in the second lowest shelf position. Put your grill dish on the lowest shelf to catch any spills. When using 'Fan Grill' it is not necessary to turn food over during the cooking cycle. Set temperature to 180°C.
Grill 	'Grill' function directs radiant heat from the powerful upper element onto the food. You can use the 'Grill' function for tender cuts of meat steak, chops, sausages, fish, cheese toasties and other quick cooking foods. Grill with the oven door closed. Preheat your grill for 3 minutes to get the best results. This will help seal in the natural juices of steak, chops etc for better flavour. You can slide your grill dish into either of the 2 spaces within the uppers pairs of support rails.
Maxi grill 	'Maxi Grill' directs radiant heat from 2 powerful upper elements onto the food. You can use the 'Maxi Grill' function for tender cuts of meat, steak, chops, sausages, fish, cheese toasties and other quick cooking foods. Grill with the oven door closed. 'Maxi Grill' allows you to take full advantage of the large grill dish area and will cook faster than normal 'Grill'. For best results it is recommended to preheat your grill for 3 minutes. This will help seal in the natural juices of steak, chops etc for a better flavour. You can slide your grill dish into either of the 2 spaces within the upper pairs of support rails.

Operating sequence – rotary control oven

Select the cooking function

- Turn the function selector in any direction to the desired cooking function. The oven cavity light will come on.

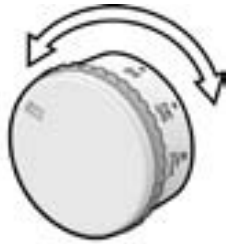

Select the temperature

- To set the temperature, turn the temperature selector in a clockwise direction to the desired setting. An indicator light above the temperature selector will come on.
- A thermostat controls the temperature in your appliance. When the temperature is reached, the heating source switches itself off and the indicator light goes out. When the oven temperature falls below the desired setting, the heating source switches on and the indicator light comes on again.
- Once the food is cooked, turn the temperature selector back in an anti-clockwise direction. Do not force it right round in a clockwise direction as this will result in damage to the thermostat.

Note:

- *The desired cooking function must be selected before the oven will operate.*



Temperature estimations

If a recipe calls for Fahrenheit (°F) or no actual temperatures, use the following table to determine the temperature (°C).

oven	temperature°C	temperature°F
Low heat		
Cool	80	175
Very slow	100-110	210-230
Slow	130-140	265-285
Moderate heat		
Moderately slow	150-160	300-320
Moderate	170-180	340-355
Moderately hot	190-200	375-390
High heat		
Hot	200-210	390-410
Very hot	220-230	430-450
Extremely hot	240-250	465-480

tips and information

Pre-heating

For best cooking results you must pre-heat your oven and grill. Pre-heating your appliance allows it to reach the required temperature quickly and efficiently as well as cook your food at the correct temperature for the entire cook time.

1. With 'Rapid Heat' function

This function allows your oven to reach preset temperature quicker than any other cooking function. Turn the function selector to 'Rapid Heat', then set the desired temperature, by rotating your oven temperature selector.

When the indicator light above the temperature selector goes out, the oven has reached the desired temperature. Select the oven function you require for cooking and place the food in the oven.

2. With other oven functions

Set the desired temperature by rotating your oven temperature selector. When the indicator light goes out the oven has reached the desired preset temperature, place your food in the oven, close the door and set the timer if you desire.

3. With 'Grill' function

Pre-heat the grill for at least 3 minutes to obtain best results. This will help to seal the natural juices of steak, chops and other meats for a better flavour.

tips and information

Your built-in appliance is fitted with a cooling fan. This prevents your kitchen cabinet from overheating and reduces the condensation inside the oven. It will operate whenever you are using your oven and blow warm air across the top of the oven door.

Condensation

- Excess condensation may fog the oven door. This may happen when you are cooking large quantities of food from a cold start. You can minimise condensation by:
 - Keeping the amount of water used whilst cooking to a minimum.
 - Making sure the oven door is firmly closed.
 - Baking custard in a baking dish that is slightly smaller than the water container.
 - Cooking casseroles with the lid on.

Note:

- *If you are using water in cooking, this will turn to steam and may condense outside your appliance. This is not a problem or fault with your oven.*

environmental tip

You can use the residual heat in the oven for keeping food warm.

Cooking with the timer – rotary control oven

Your oven is equipped with a 3 button timer that has the following features:

- Timer – you can set a countdown time that will beep when the set time has elapsed.
- Cook time – you can set cooking duration. A timer will count down the preset cooking time, beep when the time has elapsed and turn the appliance off.
- End time – instead of setting a cooking duration you can set a cooking finish time. When the finish time has been reached the timer will beep and turn the appliance off.
- Delayed start cooking time – you can combine the cooking time and end cooking time to switch oven on and off at a specific time during the day.

Selecting the timer

- Press the MODE button until the timer ‘indicator’ begins flashing.
- Set the countdown time you want by using the **–** and **+** buttons. 5 seconds after the last change the timer ‘indicator’ will stop flashing and the countdown will start in minutes.
- To stop the beeper, press any button.

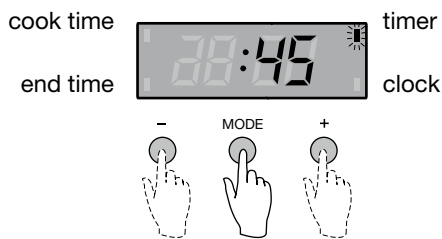

Setting the cooking duration

- Select the desired oven function and temperature.
- The oven indicator light will glow and the heating source will come on.
- Press the MODE button until the cook time ‘indicator’ begins flashing.
- Set the cooking duration you want by using the **–** and **+** buttons. Five seconds after the last change the cook time ‘indicator’ will stop flashing, and the time of day will be displayed.

Note:

- Remember to add pre-heating time if necessary.

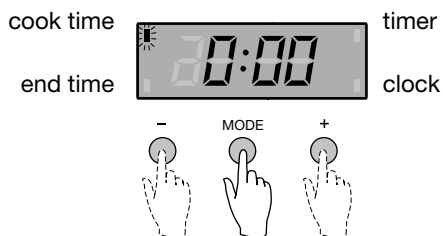

Setting the cooking end time

1. Check that the clock displays the correct time of day.
2. Select the desired oven function and temperature. The oven indicator light will glow and the heating source will come on.

3. Press MODE button until the end time ‘indicator’ begins flashing.
4. Enter the time of day you want to finish cooking by pressing **–** or **+** buttons. Five seconds after the last change, the end time ‘indicator’ will stop flashing and the current time of day will be displayed.

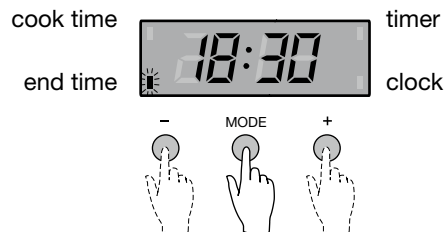

Setting the delayed start cooking time

- Set the cook time and end as described in the previous sections.
- Once both the cook time and end time have been set, the cook time and the end time ‘indicators’ will stop flashing and the current time of day will be displayed.

To check or cancel settings

- To check your settings, press the mode button until the setting you want is displayed. A red light will flash next to the mode (cook time, end time etc) that is currently on display.
- To cancel “delayed start” press the mode button until a light flashes next to “end time”. Press and hold the **–** button until the clock no longer reverses (you will hear a beep). If you have left the temperature and function knobs at a setting the oven will start once the “end time” light stops flashing.
- To cancel “auto shut off” press the mode button until a light flashes next to “cook time”. Press and hold the **–** button until the clock no longer reverses (at 0:00 you will hear a beep). This automatically cancels “delayed start”. If you have left the temperature and function knobs at a setting, the oven will start once the “cook time” light stops flashing. Because you have cancelled “auto off” the oven will continue to heat until you manually turn it off.

On completion of cooking

- The heat source will turn off, the timer will beep and the end time and/or cook time ‘indicators’ will flash.
- Even though the heating element turns off the oven will still retain substantial heat. This will continue to cook the food until it is removed or the oven cools down. If you do not plan on being present when the oven turns off, you should take this extra heating time into account.
- Turn the function and temperature controls to the off position.
- Press any button to stop the timer beeping.

Adjusting the clock

- Press the MODE button until the clock ‘indicator’ begins flashing.
- Press the **–** or **+** buttons to change the time of day. 5 seconds after the last change, the clock ‘indicator’ will disappear, confirming the time has been adjusted.

Before using your electronic control oven

Preparing your oven

1. Please remove all stickers, leaflets and boxes from the doors and the floor of the oven before operation.
2. Please wipe out the oven interior prior to operation with warm soapy water and polish dry with a soft clean cloth. Do not close the oven door until the oven is completely dry.

Setting the time (EOEE62AS, EOEE63AS, EPEE63AS, EUUE63AS, EDEE63AS)

After electrically connecting the appliance, you must set the time of day before you can operate your oven.

1. After the appliance has been electrically connected "12:00" will flash on the clock display, along with the scrolling message "Welcome to Electrolux".
2. To set the time of day in hours and minutes, press the **-** or **+** buttons.
3. 8 seconds after the last change the time will stop flashing, confirming the time has been set. Once the time has been entered, the clock advances minute by minute.

Note:

- The clock has a 12 hour display
- The display has 3 levels of brightness.
 - Brightest illumination: whenever the oven is in use.
 - Medium illumination: the oven is not in use.
 - Lowest illumination: the oven is not in use between the hours of 10pm and 6am.

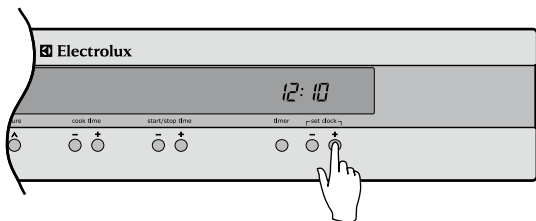

Setting the time (EOEK62AK)

- After the appliance has been electrically connected, the set clock symbol \odot and timer arrow \blacktriangleright will flash on the clock display.
- To set the time of day, press **-** or **+**. 5 seconds after the last change the timer arrow \blacktriangleright will disappear, confirming the time has been set. Once the time has been entered, the clock advances minute by minute.

Note:

- The clock has a 24-hour display.

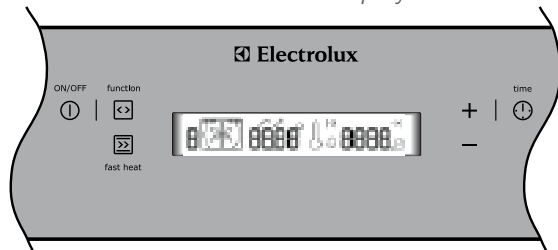

Installing your oven accessories

• Catalytic liners (if supplied)

The oven/s will already be fitted with a catalytic fan baffle and top panel. We have supplied side panels for you to fit. They can be fitted before you put the side racks on but you can omit them, if you wish, with no effect to cooking performance. Their sole purpose is to make oven cleaning easier. Of course, you can add them at any time by removing the side racks (see page 24). The catalytic liners will attach to each side of the oven. There will be a left hand and a right hand version.

1. Position the first liner as per the diagram. The black, shiny side of the liner should be facing the oven wall, the hooks pointing down and the front edge will have a narrow strip before the vertical slot (when compared to the strip at the rear edge). Note that the diagram shows the left hand liner. The right hand side will be a mirror image of this.
2. Line the hooks up with the slots provided in the oven wall, push them in and then allow the liner to slide down to its final position. **All 4 hooks MUST be engaged in slots.**
3. The access hole for the side racks should be visible when the liner is correctly positioned – see diagram.

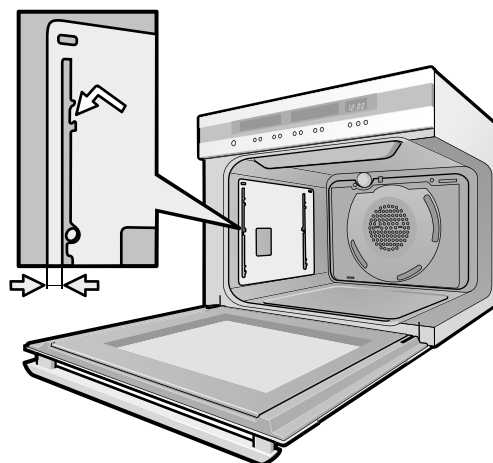

Note:

- If you have purchased an EDEE63AS or an EUUE63AS you will have additional side panels for the extra oven cavity.

i tips and information

New appliances can have a smell during first use. It is recommended to 'run in' the oven before you cook for the first time. Operate the oven empty at a temperature of 180°C for approximately 2-4 hours (see page 14 for operating sequence). Please ensure the room is well ventilated during this process.

• **Side racks and telescopic slides**

1. Insert the largest peg into rear access hole provided.
2. Then locate the front peg into the front access hole and push in firmly.

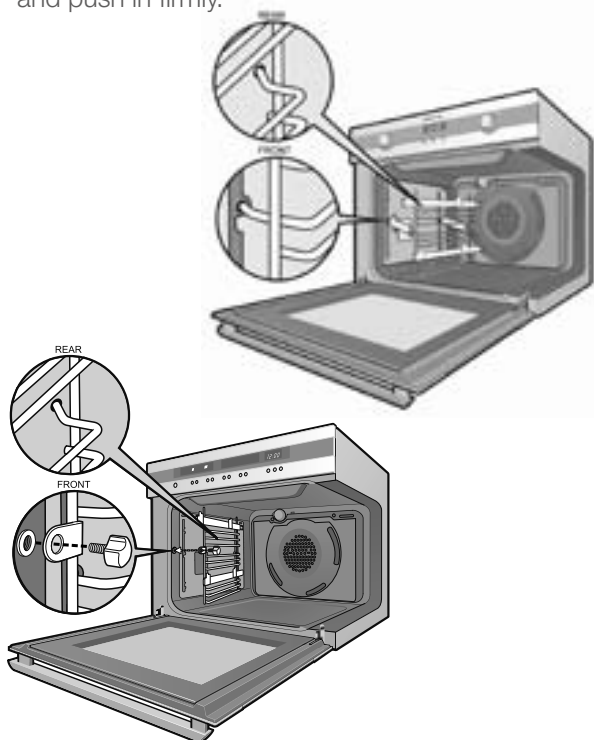

To fit a tray to telescopic slides:

1. Fully extend the slides on both sides.
2. Select the tray you wish to use and position the slots on one side on the respective tabs of the slide.
3. Drop the other side down so that the tray is fully seated on both slides.

When fully inserted the shelf/tray should not interfere with the closed oven door.

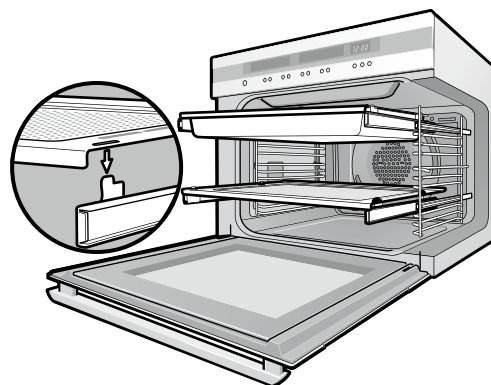

• **Fat filter (if supplied)**

The fat filter is designed to go onto the front of the fan cover at the rear of the oven. When fully engaged the filter will be positioned in the centre of the fan cover.

1. Locate the mounting slots in the fan cover and the corresponding tags on the fat filter.
2. Position the fat filter onto the fan cover with the tags pointing down.
3. Push the fat filter down into position.

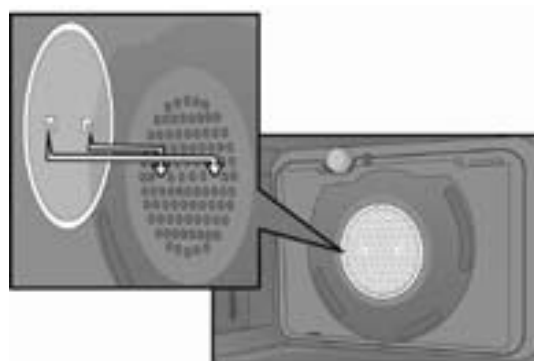

Note:

- *If you have purchased an EUJEE63AS you will have additional side racks for the lower oven/grill. These are fitted in the same manner, however the left hand side rack must be fitted to the lower two holes of the oven/grill cavity.*

• **Shelves and trays**







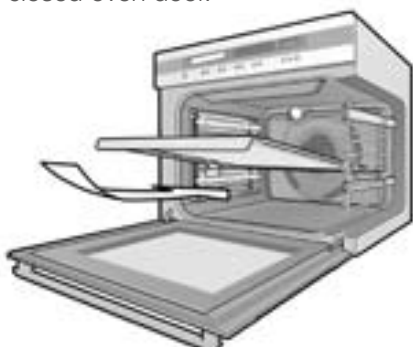





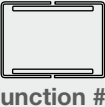
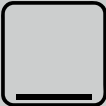
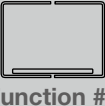

The shelves are designed so that they have maximum extension but cannot be accidentally pulled right out. The trays are designed the same way and slot straight into the side racks.

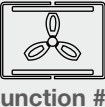
To fit a shelf or tray to side racks:

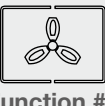

1. Locate the rear edge of the shelf/tray in between 2 guide rails of the side rack – see diagram. Ensure the same rail positions on both sides of the oven are being engaged.
2. With the front edge raised, begin to slide the shelf into the oven.
3. Once the detents have passed the front edge of the side rack, the shelf can be pushed completely in. When fully inserted the shelf/tray should not interfere with the closed oven door.

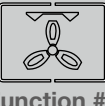

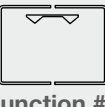
Cooking functions – electronic touch control and control oven

function	control oven	touch control oven	description
Cook from frozen		 Function #1	The “Cook from Frozen” function is ideal for cooking frozen precooked foods such as savoury pastries, pizzas, mini meals (TV dinners), meat pies and fruit pies. Heat comes from the element surrounding the fan as well as a smaller element above the food. Simply place the food in the oven straight from the freezer and heat. Cook in the upper half of the oven for best results.
Fan cooking		 Function #2	Heat comes from the element surrounding the fan. This fan circulates the hot air around the oven cavity so that you can put your food in different places in the oven and still cook them at the same time. You can use the “Fan Cooking” function for multi-shelf cooking, reheating cooked foods, pastries and complete oven meals . It will cook at a lower temperature and be faster than baking. Please note that some variation in browning is normal.
Traditional bake		 Function #3	Heat comes from two elements, one above and one below the food. The bottom element is a clean heat element and is below the floor of the oven. Both elements are controlled by the thermostat and will turn on and off to maintain set temperature. You can use the “Traditional Bake” function for single shelf cooking, single trays of biscuits, scones, muffins, cakes, slices, casseroles, baked puddings, roasts and delicate egg dishes . This is a general function that can be used for most cooking.
Pastry		 Function #4	The “Pastry” function is specially designed for food that require extra browning such as the bases of pastries and pies . Heat comes from the element below the food. If you choose the default setting, the oven will heat up to 230°C in order to brown the food. You should then drop the temperature to what the recipe required. Cook in the lower half of the oven when you are using only one shelf.
Fan assist bake		 Function #5	Heat comes from two elements, one above and one below the food. The fan circulates the hot air around the oven cavity so that you can put the food in different places in the oven and still cook them at the same time. You should only use a maximum of two shelves with “Fan Assist Bake”. Do not use the bottom shelf. If the two shelves are used, food on the shelf in the higher position will cook first and should then be removed to allow the food on the lower shelf to finish cooking.
Pizza		 Function #6	“Pizza” is a combination of “Pastry” and “Fan Assist Bake” and offers you the combined benefits of both functions. Heat switches between the element surrounding the fan and the clean heat element below the oven floor. The “Pizza” function is ideal for foods that require cooking and browning on the base. It is for foods such as pizzas, quiches, meat pies and fruit pies . Simply place the food in the middle of the oven and set the desired temperature.
Defrost		 Function #7	The “Defrost” function uses low temperature air that is circulated by the fan. You can defrost (thaw) your food before you cook it. You can also use “defrost” to raise your yeast dough and to dry fruit, vegetables and herbs . The “Defrost” function does not have a suggested temperature but uses the ambient heat in the oven cavity.
Fan grill		 Function #8	“Fan Grill” offers you the benefits of both traditional bake and traditional grill functions. The grill element turns on and off to maintain set temperature while the fan circulates the heated oven air. The oven door remains closed for fan grill. You can use “Fan Grill” for large cuts of meat , which gives you a result similar to “rotisserie” cooked meat. Put your food on a shelf in the second lowest shelf position. Put the grill dish on the lowest shelf position to catch any spills. When using “Fan Grill” it is not necessary to turn the food over during the cooking cycle. Set temperature to 180°C.
Half grill		 Function #9	The “Half Grill” directs radiant heat from only one of the powerful upper elements onto the food. The “Half Grill” function is used instead of “Full Grill” when only half the amount of heat is needed.

function	control oven	touch control oven	description
Full grill			“Full Grill” direct radiant heat from two powerful upper elements onto the food. You can use “Full Grill” function for tender cuts of meat, steak, chops, sausages, fish, cheese toasties and other quick cooking foods . Grill with the oven door closed. “Full Grill” allows you to take full advantage of the large grill dish area and will cook faster than the “Half Grill” function. For best results it is recommended to preheat your grill for three minutes. This will help seal in the natural juices of steak, chops etc for a better flavour. You can slide your grill dish into either of the two spaces within the upper pairs of support rails. “Full Grill has 2 temperature settings, ‘LO’ and ‘HI’.

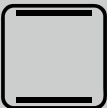
function	control oven only	description
Keep warm		The “Keep Warm” function is a low temperature oven function designed to keep your food at a perfect eating temperature without cooking it further. Heat comes from the smaller elements above the food and is circulated by the fan. Use “Keep Warm” to keep your food warm while you prepare the rest of the meal or afterwards while you wait for the late arrival. <i>Note: After cooking, the oven retains enough heat to continue to cook food even if the elements are turned off. The “Keep warm” function recognises this by giving you a warning message. If this happens the function will not start.</i>
Pyrolytic cleaning		The “Pyrolytic cleaning” function is used for cleaning the main oven. It cleans by burning off the spatters and accumulated dirt and grease from the oven liner, at high temperature. This process produces ash which can be wiped out of the oven cavity.
Roast		This function starts at a higher temperature to seal the meat. The oven will then automatically reduce to the selected temperature to cook the meat for as long as desired. For example, if you use the default 200°C the “Roast” cycle will start at 240°C and then lower to 200°C.

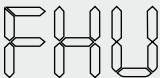
function	touch control oven only	description
Fast Heat		‘Fast heat’ can be selected in the initial heat up phase of any cooking function. During ‘fast heat’ the heat comes from the element surrounding the fan as well as the smaller element above the food. This allows you to preheat your oven 30% quicker than on standard ‘bake’.

Operating sequence – electronic control oven (except EOEK62AK)

Turning the oven on

- Switch on the oven by pressing the “ON/OFF” button. The LCD control panel will come on and inform you that you need to select a cooking function.
- If you do not select a function within 8 seconds the oven will turn off.

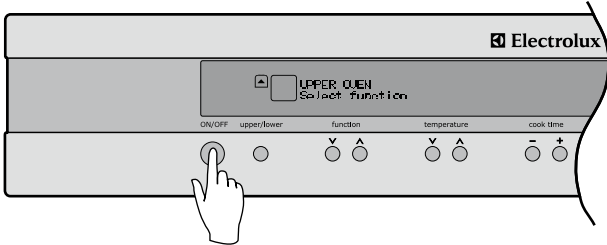

Selecting the cavity (EUUE63AS & EDEE63AS only)

Your oven may be equipped with two cavities. On these models, use the cavity selector button to toggle between the upper and lower cavity of your oven.

- Select which cavity to use by pressing the “upper/lower” button. The oven cavity icon on the LCD control panel will tell you which oven is currently active.

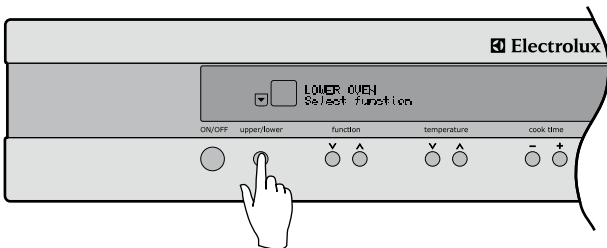

Note:

- The lower oven cavity does not have as many functions as the upper oven cavity.

Select a cooking function

Your oven will have a selection of functions. Refer to the inside front cover of this manual to confirm what functions are available to you.

- Press the “function ▼” or function ▲” buttons as many times as necessary until the desired function appears.
- Cooking suggestions will appear under the function name and suggested cooking temperatures will appear above the temperature selector.
- If no other button is touched within 8 seconds the oven will switch on and begin to heat up to the displayed temperature.

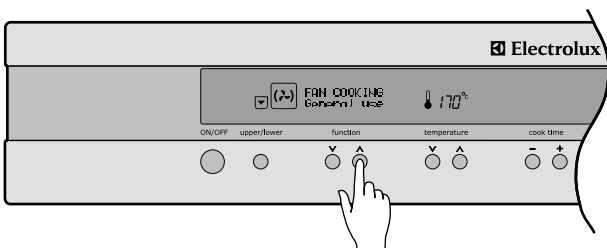

Selecting a temperature

The temperature in your appliance is electronically controlled.

- The temperature can be selected within the range of 30°C to 250°C and can be adjusted at any time. To set the temperature, press the temperature “▼” and temperature “▲” buttons to reach the desired setting.
- If no further changes are made within 8 seconds the oven begins to heat. The heating indicators above the temperature selector will come on and start to rise slowly, indicating the degree to which the oven is currently being heated.
- When the temperature is reached, the indicator bars are fully lit, the heat source switches itself off and the buzzer will play a short sound. When the oven temperature falls below the desired setting, the heating source switches back on.

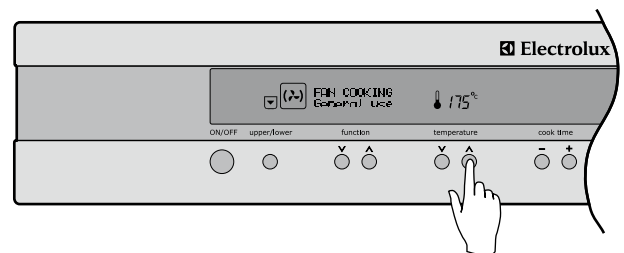

tips and information

Pre-heating your oven is recommended in several cooking and grilling functions. Pre-heating your appliance allows it to reach the required temperature quickly and efficiently as well as cook your food at the correct temperature for the entire cook time.

The programmable controller models are equipped with a built-in rapid heat-up that activates each time you start an oven function. During the rapid heat-up phase the heat comes from the element surrounding the fan as well as the smaller element above the food. This combination will heat up your oven 30% quicker than it would on standard “Bake”. The oven will automatically revert to the set cooking function once the preset temperature is reached.

Turning the oven off

Single cavity models:

1. Press the ON/OFF button to switch off the oven.

Dual cavity models:

1. Press the upper/lower cavity selector button to toggle to the desired cavity.
2. Press the ON/OFF button to switch off the desired cavity. The LCD control panel will come off to confirm that the cavity is now switched off.
3. If the other cavity is still active, after 1 second, the LCD control panel will automatically revert to show the setting of that cavity.
4. To turn off both cavities at once, press and hold the On/Off button for 1 second. All elements, cavity light and the LCD control panel will then switch off at the same time.

Cooking with the timer – electronic control oven (except EOEK62AK)

Your oven is equipped with a programmable controller that can be used to turn on and off the oven automatically. The cook time is used to automatically turn the oven off after a set amount of time.

Setting the cook time

1. Select the desired oven function and cooking temperature.
2. Press the “cook time +” button as often as necessary, until the desired cook time has been set.
3. After 8 seconds from the last time adjustment your oven will be programmed and will start cooking.

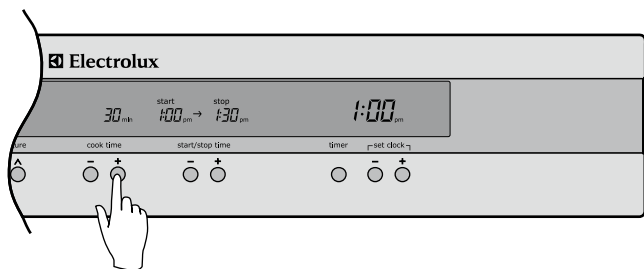

Note:

- During cooking, you can adjust the cook time with the Cook time – or + buttons for better cooking performance.

Setting the start/stop time

The start/stop time can be used to switch the oven On and Off at a specific time during the day.

1. Check the clock displays the correct time of day.
2. Select the desired oven function and cooking temperature.
3. Set the required cook time.
4. Press the “start/stop” time + button to move the start and stop time forward.
5. After 8 seconds from the last time adjustment the DELAY SET icon will light and your oven is now programmed.

The oven will start cooking when the time of day reaches the set start time.

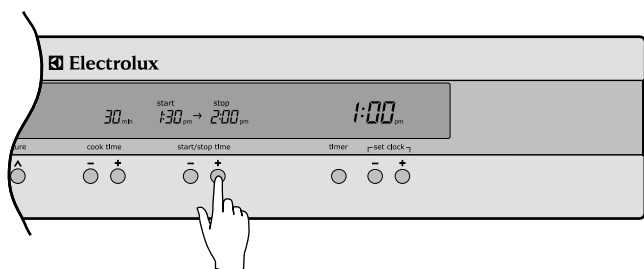

Note:

- 30 seconds after a programmed cooking function has started, it is no longer possible to delay the start time.
- In order to delay a cooking function that has already started, the oven needs to be switched Off using the ON/OFF button, then switched on again and re-programmed.

On completion of cooking

When the cook time has elapsed, an audible signal will sound for 10 seconds, the oven will switch off and COOKING FINISHED will be displayed on the left hand side of the display. On the right hand side of the display, the remaining time indication “0 min” will appear together with the cooking start and stop time.

- To stop the audible signal, press any of the buttons on the control panel.
- If you wish to cook a bit longer, press the “cook time +” button for each additional minute you require. The oven automatically reverts to the function and temperature previously programmed. This feature is available for 5 minutes after cooking has finished. After that, the oven automatically switches off.

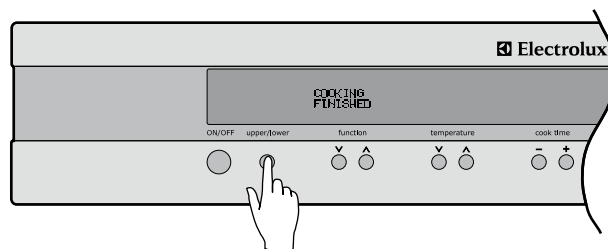

environmental tip

You can use the residual heat in the oven for keeping food warm.



tips and information

Even though the heating element turns off the oven will still retain substantial heat. This will continue to cook the food until it is removed or the oven cools down. If you do not plan on being present when the oven turns off, you should take this extra heating time into account.

Setting the timer

The timer can be used independently of the oven for setting a countdown period. When the period of time has elapsed, an audible signal sounds.

1. Press the timer button.
2. Set the desired length of time using the – or + buttons whilst the timer bell is flashing. After 8 seconds from the last adjustment the timer bell will stop flashing and the timer will start to count down.
3. When the set time has elapsed, an audible signal will sound for 10 seconds. The time indication “0 min” and the timer bell will flash on the display.
4. To stop the signal, press any of the 3 buttons below the Clock/Timer display.

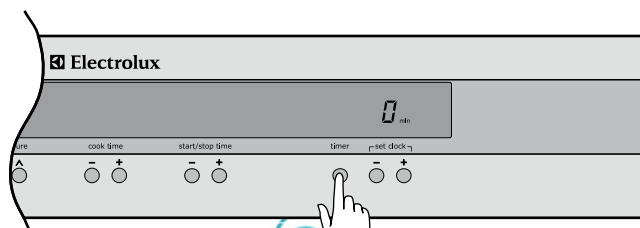

Note:

- This feature has no effect on the oven operation.

Adjusting the clock

The time of day is independent of the oven and can be adjusted at any point.

1. To set the time of day in hours and minutes press and hold the **—** and **+** buttons simultaneously for 1 second until the dots on the clock display start flashing.
2. Adjust the time of day using the **—** and **+** buttons.
3. After 8 seconds from the last adjustment, the dots will stop flashing, confirming the time has been set. You can also confirm your changes by pressing the timer button.

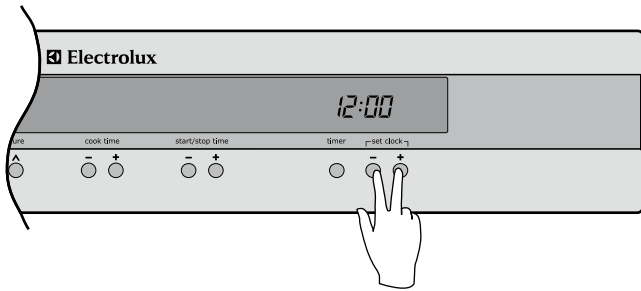

Demo Mode

This mode is intended to be used in retail shops to demonstrate the oven functionality without any power consumption except to the oven lamps.

1. Ensure the oven is off by pressing the ON/OFF button.
2. Press and hold the ON/OFF button until the display turns ON then OFF. Immediately after press the cooktime buttons simultaneously, hold until the words 'Demo mode' are displayed, a single beep will sound to confirm the operation.

Releasing Demo Mode

1. Ensure the oven is off by pressing the ON/OFF button.
2. Press and hold the ON/OFF button until the display turns ON then OFF. Immediately after press the cooktime buttons simultaneously, hold until the words 'Normal mode' are displayed, a single beep will sound to confirm the operation.

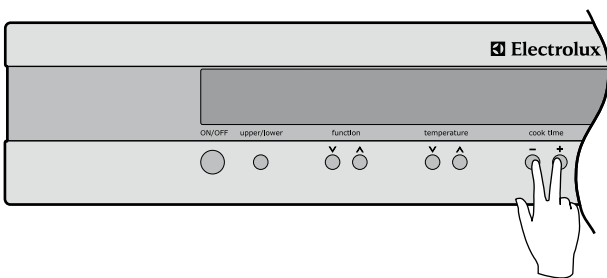

Additional functionality – electronic control oven (except EOEK62AK)

Activating the child lock

When the child lock is engaged, the oven cannot be switched on.

1. Switch off the appliance using the "ON/OFF" button.
2. Press the function buttons simultaneously, hold until the words LOCKED are displayed, a single beep will sound to confirm the operation. The child lock is now engaged.

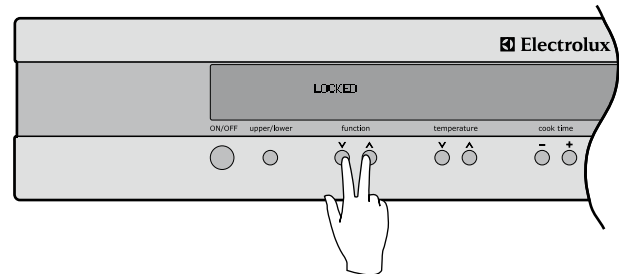

Note:

- When the child lock function is active, only the clock and timer can be set.

Releasing the child lock

Press the function buttons at the same time, hold until the word LOCKED is cleared from the display. The child lock is now released and the oven is ready to use.

Beep on touch

The beep sound can be activated anytime a button is pressed.

1. Ensure the oven is off by pressing the ON/OFF button.
2. Press the temperature buttons simultaneously for one second, a single beep will sound to confirm operation. Repeat the above procedure to reset the beep mode to touch mode. As default the beep on touch mode is off.

Maximum operation times for safety

The oven automatically switches itself off if the temperature is not adjusted or the appliance is left operating for:

- 12.5 hours when set between 30°C and 120°C
- 8.5 hours when set between 120°C and 200°C
- 5.5 hours when set between 200°C and 250°C

Operating sequence – electronic touch control (EOEK62AK)

Setting the oven function

1. Switch on the appliance by pressing the “On/Off”.
The oven lights will light.

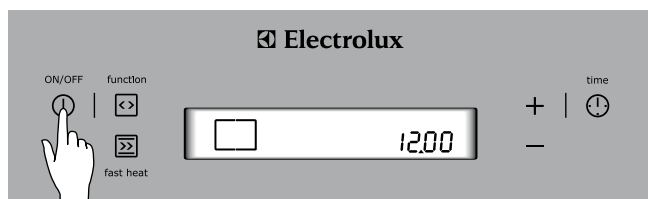

2. Press the “Function” as many times as necessary until the desired function appears. The suggested cooking temperature appears in the display and the degrees symbol “°” flashes. If the suggested temperature is not changed within approximately 5 seconds the degrees symbol “°” stops flashing and the oven begins to heat. The suggested temperature display is replaced with the oven centre temperature and a thermometer icon. The thermometer icon rises slowly, indicating the degree to which the oven is currently being heated.

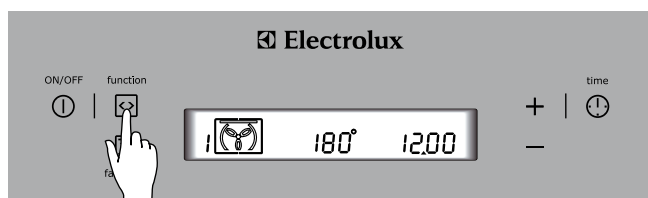

Changing the oven temperature

1. Press the **–** or **+**, to decrease or increase the temperature.

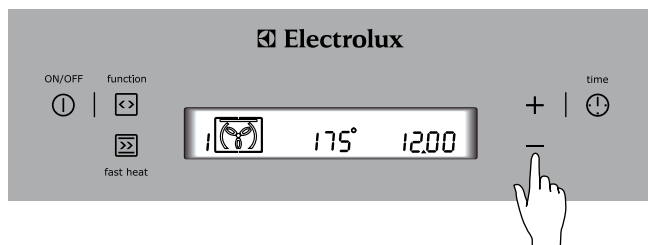

Note:

- The temperature can only be adjusted when the degrees symbol “°” is flashing. The temperature setting changes in increments of 5°C. To change the temperature after the degrees symbol “°” stops flashing, press the “Function” and then press the **–** or **+** to change the temperature.

Using Fast Heat Up (FHU) mode

To quickly and efficiently preheat your oven, it is recommended to select the “Fast Heat” cooking feature.

1. Set the oven function and temperature as described in the previous section.
2. Press the “Fast Heat”. The letters “FHU” will appear on the temperature display.
3. When the set temperature is reached the buzzer will sound and the set temperature will be displayed.

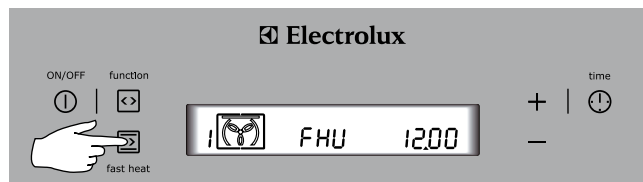

Note:

- “FHU” cannot be selected if the oven centre temperature is above the preset temperature.

Cooking with the timer – electronic touch control (EOEK62AK)

Setting the cooking time

1. Select the desired oven function and cooking temperature.
2. Press the “Time” as often as necessary, until the “cook time” **|→|** symbol appears.
3. Set the desired cooking time by using the **–** or **+**, whilst the “timer arrow” **▶** is flashing. After 5 seconds from the last time adjustment the “timer arrow” **▶** will disappear and your appliance is now programmed.
4. When the set time has elapsed, a signal will sound. To stop the signal, press “**–**” or “**+**”.

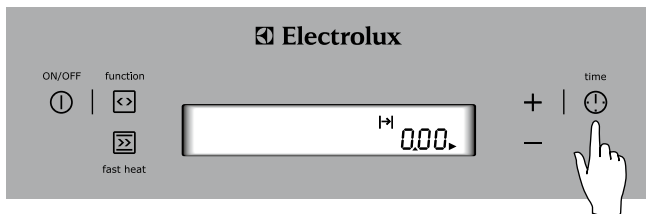

Setting the stop time

1. Select the desired oven function and cooking temperature.
2. Press the “Time” as often as necessary, until the “end time” **→|** symbol appears flashing.
3. Set the desired switch-off time using the **–** or **+** whilst the “timer arrow” **▶** is flashing. After 5 seconds from the last time adjustment the “timer arrow” **▶** will disappear and your appliance is now programmed.
4. When the set time has elapsed, a signal will sound. To stop the signal, press “**–**” or “**+**”.

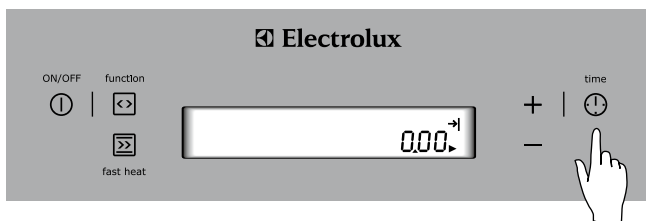

Setting the delayed start cooking time

The “cook time” **|→|** and “end time” **→|** functions can be combined to switch the oven on and off at a specific time during the day.

1. Select the desired oven function and cooking temperature.
2. Press “Time” as often as necessary, until the “cook time” **|→|** symbol appears.
3. Set the desired cooking time by using **–** or **+**, whilst the “timer arrow” **▶** is flashing.
4. Press “Time” as often as necessary, until the “end time” **→|** symbol appears flashing.
5. Set the desired switch-off time using the **–** or **+** whilst the “timer arrow” **▶** is flashing. The “cook time” **|→|** and “end time” **→|** arrows are lit to confirm that the oven has been programmed.

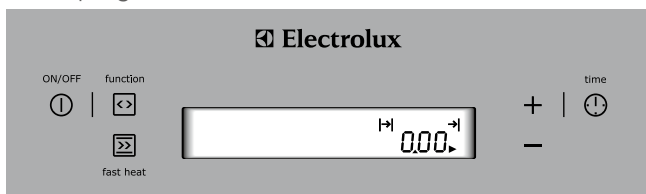

On completion of cooking

When the set time has elapsed, a signal will sound for 1 minute, the oven will switch off and the remaining time indication “0.00” will appear on the display.

1. To stop the signal, press “**–**” or “**+**”.

Setting the minute minder

For setting a countdown period. When the period of time has elapsed, an audible signal is sounded.

Note:

- This feature has no effect on the oven operation.

1. Press “Time” as often as necessary, until the “minute minder” **Δ** symbol appears flashing. Set the desired length of time using **–** or **+** whilst the “timer arrow” **▶** is flashing. After 5 seconds from the last time adjustment the “timer arrow” **▶** will disappear and the minute minder has been set. Once the set time has elapsed, a signal will sound for 1 minute. The time indication “0.00” and a flashing “minute minder” **Δ** symbol will appear on the display.

2. To stop the signal, press “**–**” or “**+**”.

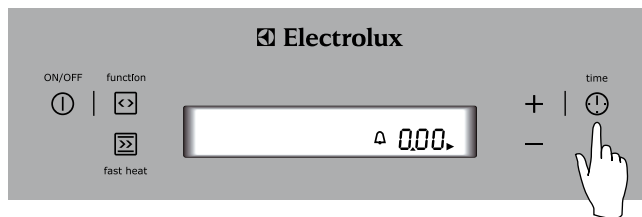

Adjusting the time

1. Switch off the appliance by pressing “On/Off”.
2. Press “Time” as many times as necessary until the “set clock” **⌚** symbol and “timer arrow” **▶** flash on the clock display.
3. Press “**–**” or “**+**” to change the time. Five seconds after the last change the “set clock” **⌚** symbol and “timer arrow” **▶** will disappear, confirming the time has been set.

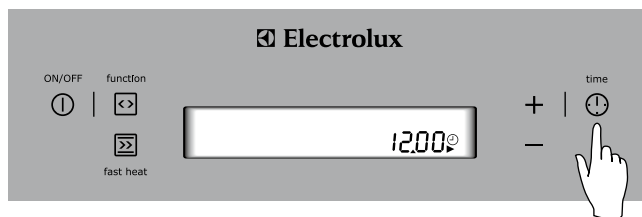

Additional functionality – electronic touch control (EOEK62AK)

Activating the child-proof lock

When the child lock is engaged, the oven cannot be switched on.

1. Switch off the appliance using the “On/Off”.
2. Press “Function” and **—** at the same time, hold until the word “SAFE” is displayed. The child-proof lock is now engaged.

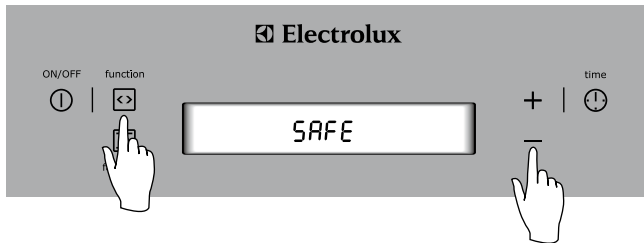

Note:

- When the child-proof lock function is active the time of day and minute minder can only be set.

Releasing the child-proof lock

1. Press “Function” and **—** at the same time, hold until the word “SAFE” is cleared from the display. The child-proof lock is now released and the oven is ready to use.

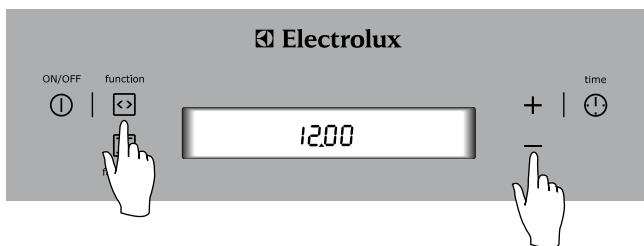

Beep on touch

The beep sound can be activated anytime when a symbol is pressed.

1. Ensure the oven is off by pressing “On/Off”.
2. Press “Function” and **+** simultaneously for 2 seconds, a single beep will sound to confirm the operation. Repeat the above procedure to reset the beep on touch mode. As default, the beep on touch mode is off.

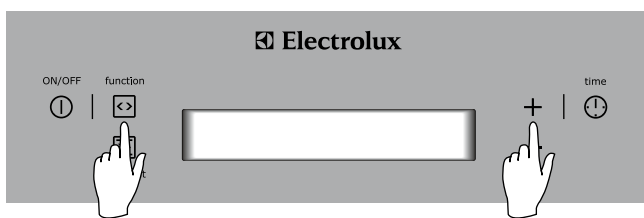

Demo mode

This mode is intended to be used in retail shops to demonstrate the oven functionality without any power consumption except for the fan and oven lamps.

This feature can only be activated when no power has been supplied to the unit for at least 10 minutes.

1. Connect the power to the appliance. The firmware number “C61 xxx” will appear.
2. Press and hold “Time” until the appliance beeps once.
3. Press and hold “Time” and **—** **simultaneously** until the appliance beeps once.

The clock will now display the time (12:00) in standby mode, and has entered demo mode. Press “On/Off” and select a function. You should see the clock symbol  next to the time. This indicates it is in demo mode. You can now select all functions without turning the elements on.

To exit demo mode, ensure the appliance is off by pressing “On/Off”, then perform steps 2 and 3 above.

Note:

- If you are unsuccessful at steps 2 or 3 above, you must disconnect the power to the appliance and wait at least 10 minutes before you try again.

Safety cut-out feature

The oven automatically switches itself off if the temperature is not adjusted or the appliance is left operating after a period of time. The oven switches itself off after:

- 20 hours when set between 30°C and 120°C
- 8.5 hours when set between 120°C and 200°C
- 5.5 hours when set between 200°C and 250°C

Cooking guide

- Select the correct shelf location for food being cooked.
- Make sure dishes will fit into the oven before you switch it on.
- Keep edges of non Electrolux baking dishes at least 40mm from the side of the oven. This allows free circulation of heat and ensures even cooking.
- Do not open the oven door more than necessary.
- Do not place foods with a lot of liquid into the oven with other foods. This will cause food to steam and not brown.
- After the oven is turned off it retains the heat for some time. Use this heat to finish custards or to dry bread.
- Do not use a lot of cooking oil when roasting. This will prevent splattering oil on the sides of the oven and the oven door.
- When cooking items that require a high heat (e.g. tarts), place the cooking dish on a scone tray in the desired shelf position.
- For sponges and cakes use aluminium, bright finished or non-stick cookware.

Condensation

Excess condensation may fog the oven door. This may happen when you are cooking large quantities of food from a cold start. You can minimise condensation by:

- Keeping the amount of water used whilst cooking to a minimum.
- Making sure the oven door is firmly closed.
- Baking custard in a baking dish that is slightly smaller than the water container.
- Cooking casseroles with the lid on.
- If you are using water in cooking, this will turn to steam and may condense outside your appliance. This is not a problem or fault with your oven.

Roasting meat

- Place the meat in the oven and set the temperature between 180°C and 200°C. (It is recommended to wrap your meats in an oven roasting bag or foil to prevent fats and oils from splattering. This will make it easier to clean your oven.)
- Use the grill/oven dish and smokeless grill insert. Place the meat on the insert.
- Do not pierce the meat.
- When the meat is cooked, take the roast out of the oven, wrap in aluminium foil and leave to stand for about 10 minutes. This will help retain the juices when the meat is carved. The table in the next column shows temperatures and cooking times for different kinds of meat. These may vary depending on the thickness and bone content of the meat.

Roasting poultry and fish

- Place the poultry or fish in an oven set at a moderate temperature of 180°C.
- Place a layer of foil over the fish for about three quarters of the cooking time. The table shows the temperatures and the cooking times for different kinds of fish and poultry. These may vary depending on the thickness and bone content of the meat.

Oven shelf location

Your oven has 8 positions for shelves. These are numbered from 1 (the lowest shelf position) to 8 (the highest shelf position). To give maximum space above and below the shelves, load them in this way:

- When cooking with 1 shelf, position at 3, 4, 5 or 6.
- When cooking with 2 shelves, position them at 3 and 7. Refer to cooking guide.

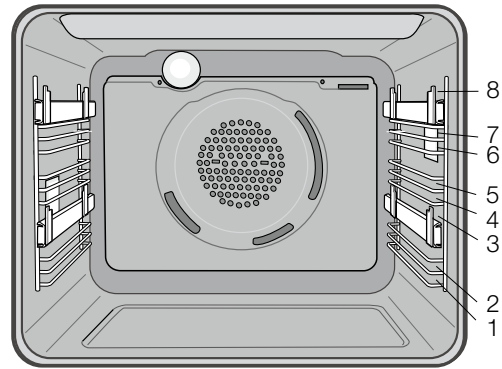

environmental tip

Use the oven efficiently by cooking many trays of food at the same time. For example:

- Cook 2 trays of scones, small cakes or sausage rolls.
- Cook a roast dinner at the same time as you cook chips or vegetables.

Cooking guide

meat	recommended temperature°C	minutes per kilogram	
Beef	200	Rare	35-40
		Medium	45-50
		Well done	55-60
Lamb	200	Medium	40
		Well done	60
Veal	180	Well done	60
Pork	200	Well done	60

poultry and fish	recommended temperature°C	minutes per kilogram
Chicken	180	45-50
Duck	180-200	60-70
Turkey	180	40-45 (<10kg)
		35-40 (>10kg)
Fish	180	20



tips and information

Your appliance is fitted with a cooling fan. This prevents your kitchen cabinet from overheating and reduces the condensation inside the oven.

It will operate whenever you are using your oven and blow warm air across the top of the oven door.

Note:

- If the oven is still hot from cooking, the cooling fan will keep running to cool the oven down and will switch off by itself once cool.

tips and information

The following tables are intended as a guide and experience may show some variation in cooking times necessary to meet individual requirements.

tips and information

For best cooking results you must Pre-Heat your oven and grill. Pre-heating your appliance allows it to reach the required temperature quickly and efficiently as well as cook your food at the correct temperature for the entire cook time.

Temperature estimations

If a recipe calls for Fahrenheit (°F) or no actual temperatures, use the following table to determine the temperature (°C).

oven		temperature°C	temperature°F
Low heat	Cool	80	175
	Very slow	100-110	210-230
	Slow	130-140	265-285
Moderate heat	Moderately slow	150-160	300-320
	Moderate	170-180	340-355
	Moderately hot	190-200	375-390
High heat	Hot	200-210	390-410
	Very hot	220-230	430-450
	Extremely hot	240-250	465-480

Traditional Bake

food		temperature°C	oven shelf position*	time in minutes
Scones	Plain or fruit	220	2	10-15
Biscuits	Rolled	170	2	10-15
	Spooned	190	2	12-15
	Shortbread biscuits	160	1 or 2	30-35
Meringues	Hard – individual	110	2	90
	Soft – individual	180	2	15-20
	Pavlova – 6 eggs	110	1	75
Cakes	Patty cakes	190	3	15-20
	Sponge – 4 eggs	180	2	20-30
	Shallow butter cake	180	2	30-40
	Rich fruit cake	140	2	180
Pastry – Shortcrust	Cornish pasties	200	2	40-45
	Custard tart	200/180	1	10/30-30
Pastry – choux	Cream puffs	210	2	25-30
Yeast goods	Bread	210	1	25-30

*Counting from the bottom shelf up

Fan cooking

food		temperature°C	oven shelf position*	time in minutes
Scones	Plain or fruit	210	Any	10-15
Biscuits	Rolled	150	Any	10-15
	Spooned	180	Any	12-15
	Shortbread biscuits	150	Any	30-35
Meringues	Hard – individual	100	Any	90
	Soft – individual	165	Any	15-20
	Pavlova – 6 egg	100	Any	75
Cakes	Patty cakes	180	Any	15-20
	Sponge – 4 egg	170	Any	20-30
	Shallow butter cake	170	Any	30-40
	Rich fruit cake	130	Any	180
Pastry – Shortcrust	Cornish pasties	180	Any	40-45
	Custard tart	190/170	Any	20-30
Pastry – choux	Cream puffs	200	Any	25-30
Yeast goods	Bread	200	Any	25-30

*Counting from the bottom shelf up

Grilling guide

Grilling hints

As a method of cooking, grilling can be used to:

- Enhance the flavours of vegetables, fish, poultry and meat.
- Seal the surface of the food and retain natural juices.
- You can grill with the door open or closed.

This table shows how to grill different types of meat:

food	grilling method
Beef	You can use tenderloin, rump and sirloin. Brush with oil or melted butter, especially if the meat is very lean.
Lamb	You can use the loin chops, shortloin chops, chump chops and forequarter chops. Remove skin or cut at intervals to avoid curling. Brush with oil or melted butter.
Sausages	Prick sausages to stop skin from bursting.
Poultry	Divide into serving pieces. Brush with oil.
Fish	Brush with oil or melted butter and lemon juice.
Bacon	Remove rind. Grill flat and make into rolls.

Note:

- *Always clean the grill/oven dish after every use. Excessive fat build up may cause a fire.*

Guide to better grilling

No definite times can be given for grilling because this depends on your own tastes and the size of the food.

These times should only be used as a guide and remember to turn the food over half way through the cooking process.

food	time in minutes
Steak	15-20
Chops	20-30
Fish	8-10
Bacon	4-5

For better grilling results, follow these easy instructions:

- Remove oven/grill dish and grill insert and preheat grill for about 5 minutes.
- Choose only prime cuts of meat or fish. If the cut is less than 5mm thick it will dry out. If the cut is more than 40mm thick, the outside may burn whilst the inside remains raw.
- Do not place aluminium foil under food as this prevents fats and oils from draining away, which could result in a fire.
- Baste the food during cooking with butter, olive oil or marinade. Grilled food is better if marinated before cooking.
- Use tongs to turn food as a fork pierces the surface and will let juices escape.

Fan grill

The Fan grill function will assist the grilling process by circulating the heat evenly around the food. The recommended temperature setting is 180°C for all fan grilling functions.

- Use the smokeless grill insert and oven dish for all fan grilling.
- Position the dish in the lower half of the oven, for best results.
- Wipe off any oil or fat which splatters while the oven is still warm.
- There is no need to turn meat as both sides are cooked at the same time which means the food is succulent.

Dealing with cooking problems

problem	causes	remedies
Uneven cooking	Incorrect shelf position	Select shelf that puts the food in the centre of the oven
	Oven tray too large	Experiment with other trays or dishes
	Trays not centralised	Centre trays
	Air flow in oven uneven	Rotate food during cooking
	Grill dish affecting thermostat	Remove grill dish from oven on bake modes
Baked products too brown on top	Oven not preheated	Preheat oven
	Baking tins too large for the recipe	Use correct size tins
	Baking tins not evenly spaced	Stagger baking tins at least 3cm between tins and oven walls
	Products not evenly sized or spaced on trays	Make into same size and shape, and spread evenly over trays
	Baking temperature too high	Lower the temperature
Baked products too brown on bottom	Baking tins too large for the recipe	Use correct size tins
	Baking tins are a dark metal or glass	Change to shiny, light tins or lower the temp by 10°C
	Food too low in the oven	Cook one shelf higher
	Oven door opened too frequently during baking	Don't open the door until at least half the cooking time has passed
	Baking temperature too high	Lower the temperature
	Grill dish affecting thermostat	Remove grill dish from oven and bake on modes
Cakes have a cracked thin crust	Baking temperature too high	Lower the temperature
	Food too high in oven	Cook one shelf lower
	Cake batter over mixed	Mix just long enough to combine ingredients
	Pan too deep	Check size of pan and use
	Baking pans dark	Change to shiny pans
Baked products are pale, flat and undercooked	Baking temperature too low	Raise the temperature
	Food too low in oven	Cook one shelf higher
	Baking time too short	Increase the cooking time
	Incorrect size tin	Use the correct size tin
Cakes fallen in the centre	Baking temperature too low	Raise the temperature
	Baking time too short	Increase the cooking time
	Proportions of ingredients incorrect in the recipe	Check recipe
	Open door too early in baking	Do not open door until the last quarter of cooking time
Roast meat, potatoes not browning in fan oven	Poor air circulation	Elevate food onto a rack to allow air circulation
	Grill dish affecting thermostat	Remove grill dish from oven on bake modes
Juices running out of meat		Do not pierce meat with a fork
		Turn with tongs
Grilled meats outside is overcooked and centre is raw		Grill at lower insert position
Grilled chops and steaks curling		Cut into fat every 2cm

Maintenance and cleaning

warning

- **Do not use steam cleaners.**
- **Do not line the bottom of the oven with foil or cookware.**

Stainless steel

- All grades of stainless steel can stain, discolour or become greasy. You must clean these areas regularly by following the procedures below, if you want your appliance to look its best, perform well and have a long life.
- Care must be taken when wiping exposed stainless steel edges, they can be sharp!
- The front frame around the oven can be cleaned with stainless steel cleaners if it becomes soiled or discoloured.
- A suitable cleaner can be purchased from Electrolux Customer Care Centres.

caution

- The front of the product is clad with a special stainless steel that resists finger marks and should only be cleaned with warm water and a mild detergent.
- **DO NOT** use stainless steel cleaners, abrasive cleaners or harsh solvents.

Note:

- *Make sure you follow the polish or brushing lines in the steel.*

Glass

- Glass surfaces on doors and control panels are best cleaned immediately after soiling.
- A damp cloth may help remove baked on food deposits.
- Oven cleaners can be used to remove stubborn marks and stains.

caution

The door glass on this appliance is made from a tough, durable material that withstands heating and cooling without breaking.

However, it must be remembered that it is GLASS, it may break. Treat it accordingly! Should you have any questions about the glass in your new appliance, please contact the customer care centre by dialling 1300 363 640.

Do not use harsh abrasive cleaners or sharp metal scrapers to clean the oven door since they can scratch the surface, which may result in shattering of the glass.

Oven

- Always keep your appliance clean. Ensure fats and oils do not accumulate around elements, burners or fans.
- Always keep the oven dish, bake trays and grill dish inserts clean, as any fat deposits may catch fire.
- Always wrap your meats in foil or an oven roasting bag to minimise cleaning. Any polyunsaturated fats can leave a varnish-like residue which is very difficult to remove.

Note:

- *Refer also to Pyrolytic oven cleaning on page 27. (EPEE63AS model only)*

Grill

- Always keep the grill dish and grill insert clean, as any fat deposits may catch fire.

Cleaning your accessories

Removing the trays and shelves from your appliance

- Slide the dish and shelves towards you until they reach the front stop.
- Tilt them up at the front to clear the side supports, taking care not to spill the contents.
- Lift them clear.
- Wash the dish and insert the shelves in hot soapy water.
- Reverse the above steps to put the grill dish and shelves back again.
- Ensure that they are placed between two support wires.
- To remove a tray from a sliding position:
 - Pull tray towards you until it stops.
 - Lift the tray clear of locating tabs.

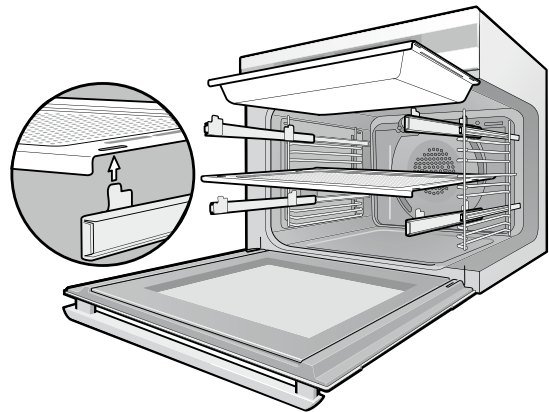

Removing the side racks

- Grasp the supports at the front.
- Pull them firmly inwards.
- To install the shelf supports, first insert the rear hook into the rear hole. Then locate the front peg into the front hole and push in firmly.

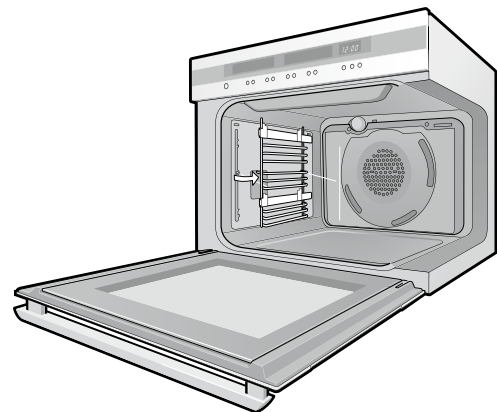

Replacing the oven top light (EPEE63AS model only)



warning

IMPORTANT: Make sure the appliance is turned off before you remove or replace parts, to avoid the possibility of electric shock.

Removing and replacing the oven back light and side light

- Turn oven light glass anticlockwise to remove it for globe replacement.
- To remove side light, place a spoon under the light glass and lever off. Replace globe and snap glass cover back into position.
- A special high temperature resistant globe should be used. This can be purchased from Electrolux Customer Care Centre.

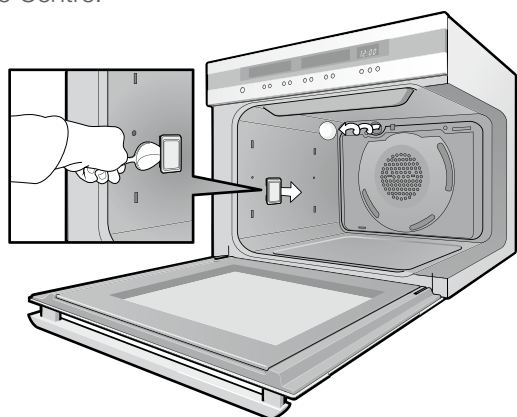

- The top light is positioned behind the grill deflector at the top of the oven.
- To remove the globe the shelves should first be removed from the oven and the top element dropped down.
- Insert a small screwdriver into the glass cutout between the two metal clips on the left hand side, as shown in the diagram.
- Gently lever the glass cover off, by pushing the screw driver in and moving it upwards, whilst holding the glass cover with the other hand. (If not supported, the glass cover may fall and break).

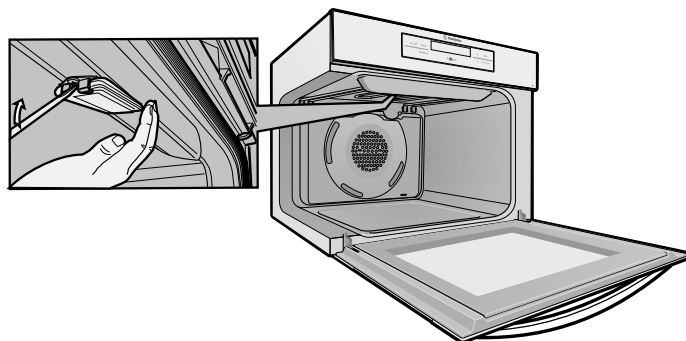

- Remove the faulty globe by pulling it directly out of its holder.
- Replace the old globe with a new one, ensuring not to directly touch the surface of the globe with your fingers, (A tissue or soft cloth is best for this.)

Releasing the grill element

We have designed the upper element with a rotating latch to help you reach your oven roof for cleaning.

- Rotate latch until the element drops down freely.

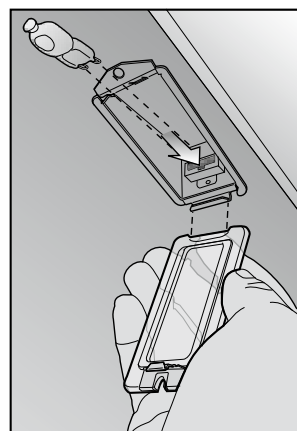
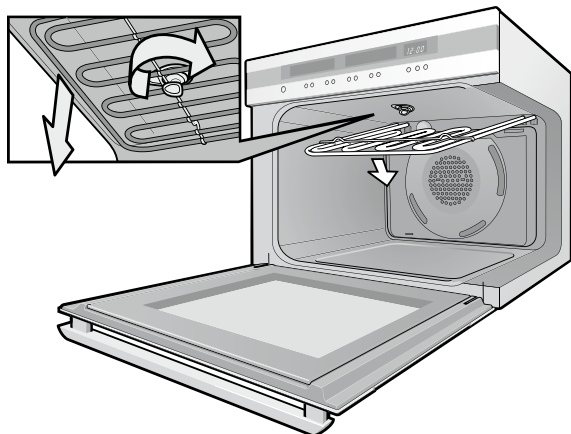

- Pick up the glass cover and place short edge into right side of housing; push up opposite end of glass cover until it snaps into position.
- Resecure the top element in place.

Catalytic self cleaning panels

Operation

Catalytic self clean panels are coated with a specially formulated enamel coating, over a base of regular enamel. This enamel coating has a rough surface which is also porous. During normal cooking, fats and other food splatter is partially absorbed into the surface and then oxidises away. This oxidation of the fat works best if the oven is set at high temperatures, You will find that if you do a lot of lower temperature baking, say around the normal 180°C, then the cleaning process may not be complete. Every now and then you should turn the oven on to 250°C for around one hour to completely remove the soil.

Cleaning

Should the panels become heavily soiled, they will need to be taken out of the oven and cleaned by hand. They should be soaked in warm, soapy water for at least 2 hours and then wiped clean with a soft cloth.

Note:

- It is not recommended that the catalytic liner in the top of the oven be removed.



caution

Solid cleaning powders, creamy cleansers, caustic oven cleaners, steel wool or other scourers will ruin the catalytic surface and must NEVER BE USED.

Removing catalytic liners

- Remove the side racks (see page 24).
- Lift the liner up to disengage the hooks.
- The liners should now be free to be pulled in towards the centre of the oven.

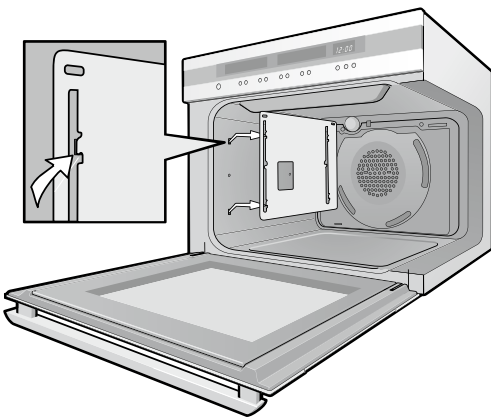

Removing and replacing the catalytic fan baffle

- To remove the fan baffle
 - Remove the 2 retaining screws on the top edge of the fan baffle.
 - Pull the top edge towards you and then disengage to bottom tabs from the oven back.
- To replace the fan baffle
 - Insert the two tabs at the bottom of the fan baffle into their corresponding slots in the oven back.
 - Push the top home and insert screws firmly into appropriate holes.
 - The fan baffle must not be loose.

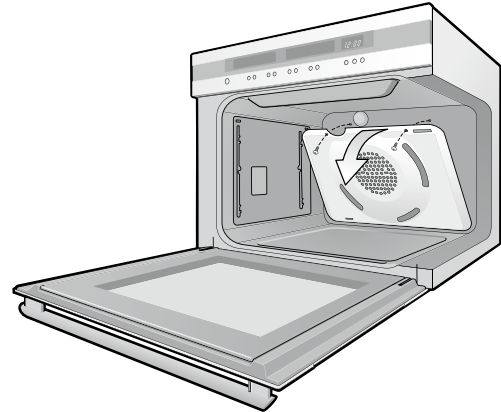

warning

It is critical that the fan baffle is replaced after cleaning, before the oven is operated again.

Fat Filter

- The Fat Filter must be cleaned every time fatty or oily food has been cooked.
- The Fat Filter can be cleaned in a dishwasher.



appliancesonline
.com.au

Australia's largest online appliance retailer

Pyrolytic cleaning of the oven cavity (EPEE63AS model only)

Operation

If your oven has the Pyro self-cleaning function, it cleans by burning off the spatters and accumulated dirt and grease from the oven liner, at high temperature. This process produces ash which can then be wiped out of the oven cavity.



caution

During the pyrolytic cleaning process the oven becomes very hot (approximately 500°C).

- Please keep small children at a safe distance
- During pyrolytic cleaning the air outlet vent above the door must be kept clear of any obstruction (eg bulky tea towels).
- It is recommended you clean your oven regularly to keep the oven in its best condition.
- Do not use your oven to clean miscellaneous items (eg cookware).

Before carrying out the Pyro function,

All accessories must be removed from the oven.

This includes shelves, trays and side racks.

Clean large pieces of dirt or grease from the oven liner.

Note:

- As an added safety feature the Pyro cycle will not start if you have left the right hand telescopic side rack in. A switch detects the presence of the rack and will not allow Pyro to start until it is removed.

There are 3 Pyro cleaning cycles you can use.

Soiling	Duration
Light Clean	2hrs 00min
Medium clean	2hrs 30min
Heavy clean	3hrs 00min

Duration includes heat-up time and cool-down time of 45 mins

• Light clean

This is an energy saving cycle that can be used on a regular basis if your oven is lightly soiled. Possibly after every 2nd or 3rd time you roast meat.

• Medium clean

Use this as your regular cycle about once every 2-3 months to remove mildly dirty ovens.

• Heavy clean

When your oven is very dirty it may need a longer cycle to clean it thoroughly. This cycle will clean the dirtiest of ovens.

Selecting the Pyro clean function

Select Pyro clean by using the function button.

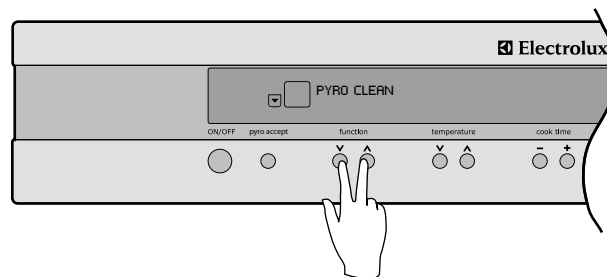

Selecting the required cleaning cycle

Select Light, Medium or Heavy depending on the soiling of the oven. This is done by pushing the cook time button to the appropriate time.

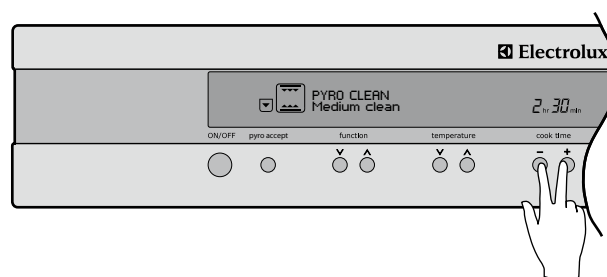

Selecting Pyro accept

After selecting the required cleaning cycle, push the Pyro accept button and the function will then start automatically. The oven light will then go out and the Pyro function will start.

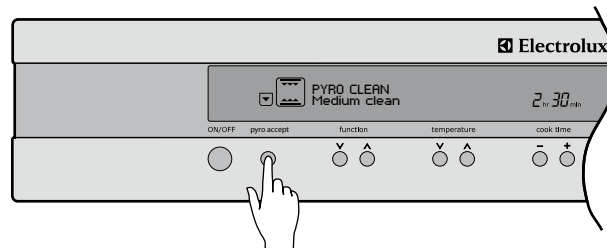

i tips and information

During Pyro cleaning the door will automatically lock when the temperature in the oven approaches 300°C. (A lock symbol will appear on the display.)

The door will only unlock when the oven has cooled to a safe temperature. Turning the function off will not unlock the door. This will only happen when safe temperatures are reached.

Note:

- The cooling fan will operate at an increased speed for Pyro cleaning and will continue to run until the oven has cooled down. This is normal.

After Pyro cleaning

After cool-down you can wipe the ash out of the oven with a soft damp cloth and warm water.

To restore the enamel shine to more difficult areas, use a damp cloth with vinegar and detergent.

Cleaning the pyrolytic oven door (EPEE63AS model only)

Your pyrolytic oven is equipped with an oven door that can be disassembled in order to clean all the panes of glass.

Positioning the door for dismantling

The door needs to be positioned at an angle to aid in the disassembly of the panes.

- Open the oven door fully and flip out the hinge locating tab to the open position.

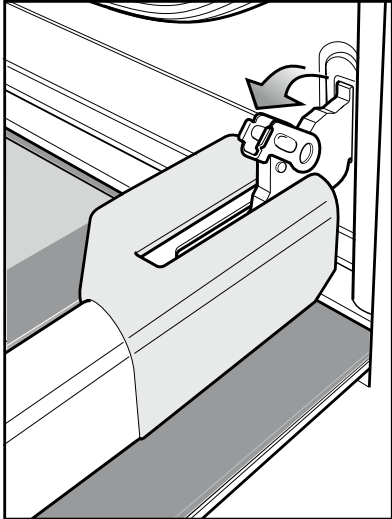

- After the locating tab has been positioned, gently close the oven door until it stops on the locating tab. The door is now ready for dismantling.

Removing the top door trim

- Push in the 2 buttons on either side of the trim.
- Lift the trim away from the door.

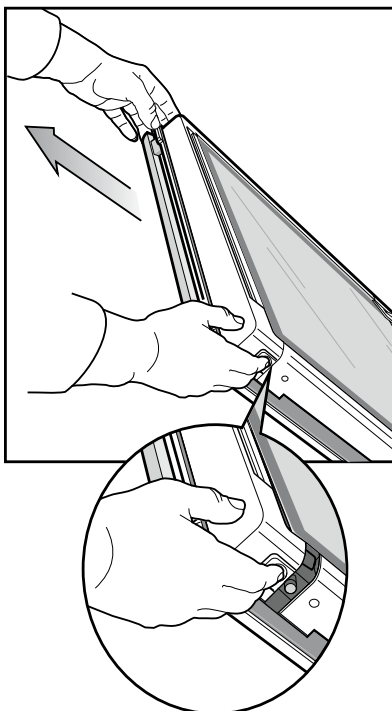

Removing the glass panes

- Remove the 3 panes of glass starting with pane 1.
- When removing pane 3 ensure that the 2 rubber supports are removed before cleaning.

Do not misplace them!

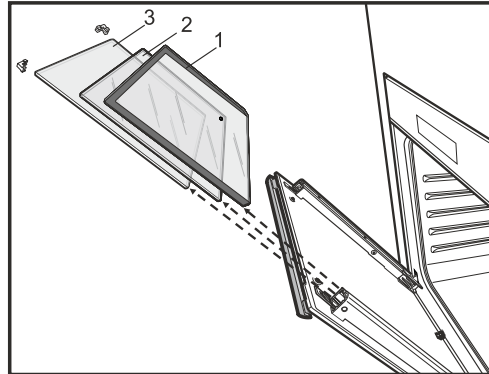

Cleaning the glass panes

Clean with a damp cloth.

Do not use scouring agents or abrasive sponges as these could damage the reflective surface.

Dry thoroughly before reassembly.

Replacing the glass panes

- Replace the glass panes back into the door starting with pane 3.
- Ensure this pane is placed into the correct slot and that the 2 rubber supports are in place.
- Next replace pane 2. There is a reflective coating on this pane. This coating is indicated by a circle printed on its surface. Ensure this circle is in the same corner as pictured below.

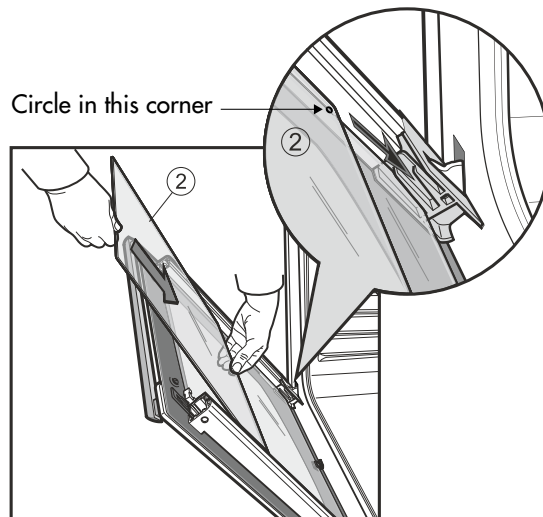

- Replace pane 1 ensuring the black screening is facing inwards towards the oven.

Replacing the top door trim

Replace the trim ensuring the clips snap into the 2 location holes. Flip the hinge locating tab back into its original position and close the door.

Cleaning the pyrolytic oven

When the pyrolytic cleaning function is on, it is advisable not to use a cooktop if it is fitted above the oven. This could cause overheating and damage to both appliances.



warning

IMPORTANT: Do not turn off the mains power supply to the oven during the pyrolytic cycle. A power failure could cause a temperature increase of the surround or cabinet.

Using the Oven

- Always cook with the oven door closed.
- Stand clear when opening the drop down oven door. **Do not** allow it to fall open. Always support the door using the door handle, until it is fully open.
- **Do not** lean on an open oven door, or place heavy items on it. This could damage the appliance. Take care in the region of the hinges.

Condensation and Steam

Hot steam may be produced when using some cooking modes. Take care when opening the oven door and always use oven mitts or pot holders to handle hot cooking utensils. This oven is supplied with an exclusive system which produces a natural circulation of air and the constant recycling of steam.

This steam makes it possible to cook in a steamy environment and keep the dishes soft inside and crusty outside. Moreover, the cooking time and energy consumption are reduced to a minimum. During cooking steam may be produced which can be released when opening the oven door. This is absolutely normal.

Always stand back from the oven when opening the oven door during cooking or at the end of it to allow any build up of steam or heat to be released.

When food is heated it produces steam in the same way as a boiling kettle does. When steam comes in contact with the oven door glass, it will condense and produce water droplets. To reduce condensation, ensure the oven is well heated before placing food in the oven cavity. Oven preheating will be necessary before any cooking. We recommend that any condensation be wiped away after each use of the oven.



tips and information

Do not place cookware directly on the oven base.

Do not place objects on the oven base and do not cover any part of the oven with aluminum foil while cooking, as this may cause a heat build-up which would affect the baking results and damage the oven enamel.

The effects of dishes on cooking results

Dishes and tins vary in their thickness, conductivity, colour etc. which affects the way they transmit heat to the food inside them.

- Aluminum, earthenware, oven glassware and bright shiny utensils reduce cooking and base browning.
- Enamelled, cast iron, anodized aluminum, aluminum with non-stick interior and coloured exterior and dark, heavy utensils increase cooking and base browning.

The middle shelf position allows for the best heat distribution. To increase base browning simply lower the shelf position. To increase top browning, raise the shelf position.

Always place dishes centrally on the shelf to ensure even browning.

Do not place dishes, tins or baking trays directly on the oven base as it becomes very hot and damage will occur.

Single level cooking gives best results in conventional modes. If you require more than one level cooking use the fan cooking function.



appliancesonline
com.au

Australia's largest online appliance retailer

Troubleshooting

Faults

If there is a problem with the oven and/or grill, please:

- Check the points listed below before calling for service.
- It may be possible to avoid a call by fixing the problem yourself – and so continue cooking.

Note:

- *We may charge for service even in the guarantee period if your problem is due to the causes listed below.*

problem	possible cause
Oven or grill not working	Time of day is not set
	Power is not turned on
	Controls are incorrectly set
	Household fuse has blown or power supply is off (If the household fuse continues to blow, call the Service Centre)
	Child-proof oven lock is activated (Refer to operating instructions)
Oven light not working	Lamp blown or loose socket
	Household fuse has blown (If the household fuse continues to blow, call the Service Centre)
Oven not heating enough	Foil trays on bottom of oven
	Timer is in 'AUTO' mode. (Refer to operating instructions)
	Household fuse has blown (If the household fuse continues to blow, call the Service Centre)
	Oven is in 'Demo mode'. Turn the oven off, then press the - and + buttons underneath cook time, at the same time. 'Normal mode' should now be displayed
Clock flashing on display	Power failure or interruption
	Reset time of day and any cooking functions you were using. (Refer to CLOCK operating instructions)
Unit smoking when first used	Protective oils being removed (see page 6)
Condensation build up	Reduce the amount of water used in cooking. (Sometimes condensation is normal)
Door cannot be replaced after removal	Stirrup not engaged properly
Pyrolytic cycle not working	All accessories must be removed from the oven see page 27
Functions and temperature appear on display but oven does not work	Oven is in 'Demo' mode, refer to Additional Functionality on page 17

Data plate

When you need information, service or spare parts please be prepared to tell us the:

- Model
- Model number
- Serial number shown on the data plate. The data plate is visible when the oven or grill door is open.

Customer Care Centre

If you need more information, please contact the Customer Care Centre:

Australia – 1300 363 640, 8am-5pm EST Mon-Fri.

New Zealand – +649 573 2384, 8am-5pm EST Mon-Fri.

If you have a warranty or spare parts enquiry, you should call the number listed on the back page.

Installation



warning

Please follow the points below when installing the appliance

Use an authorised person

- As stated in the local municipal building codes and other relevant statutory regulations:
- Wiring connections must be in accordance with AS/NZS 3000 Wiring Rules and any particular conditions of the local authority.
- Refer to data plate for rating information. The data plate is positioned behind the bottom of the oven door. The circuit diagram is positioned on the top panel of the appliance.
- A functional switch should be provided near the appliance in an accessible position. Refer to AS/NZS 3000 clause 4.7.1
- Wiring should be protected against mechanical failure. Refer to AS/NZS 3000 clause 1.5
- A means of disconnection with a contact separation of at least 3mm must be supplied in the fixed wiring.



warning

This appliance must be properly earthed.

- Do not lift the appliance by the door handles.
- Prepare the cupboard opening to match your appliance measurements. (See diagrams)
- Slide appliance into the cupboard, ensuring that the supply cable (where fitted) does not kink.
- To prevent tipping, use the screws supplied to secure your oven into the cupboard by fastening through the 2 holes to the front panel.
- Where the appliance is built into a cabinet, the cabinet must be capable of withstanding 70°C. Installation into low temperature tolerant cabinetry (e.g. Vinyl coated) may result in deterioration of the low temperature coating by discolouring or bubbling.
- If the appliance is to be installed adjacent to vinyl wrapped surfaces, use an installation kit available from the vinyl-wrap supplier.
- Electrolux Home Products cannot accept responsibility for damage caused by installation into low temperature tolerant cabinets.
- After installation, test and ensure that the appliance operates correctly before handing it over to the customer.

Note:

- If a powerpoint is fitted it must be accessible with the appliance installed, as the plug must be accessible after installation.



warning

To avoid any potential hazard, you must follow our instructions when you install your appliance. Failure to install the appliance correctly could invalidate any warranty or liability claims and lead to prosecution.

Cabinet construction for your appliance

For the best integration within a kitchen, install this appliance in a standard 600mm wide cupboard that gives a flush fit with the surrounding cupboard fronts. It can also be installed using a proud fit.

Flush Fit

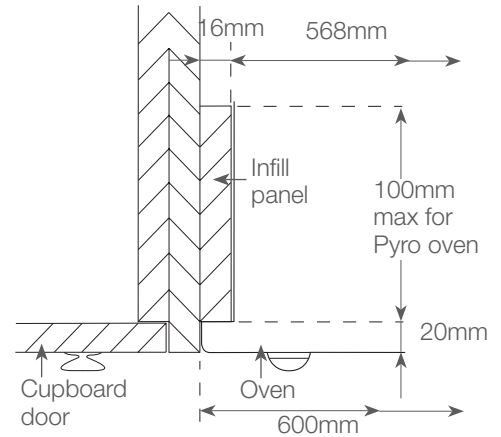

Proud Fit

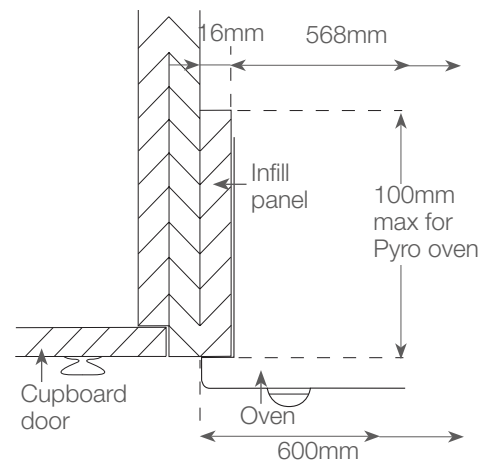

Note:

Your appliance must be mounted on a flat surface for the full width and depth of the product

Underbench oven

Your underbench oven looks best when the control panel is directly under the benchtop. An upper infill panel may be added if the cooktop placed above the benchtop is too deep. Refer to cooktop installation instructions for required clearance between cooktop and oven.

Cut-out dimensions

type of fit	A (width)	B (height)	C (depth)
Flush fit (mm)	600	600	581 min.
Proud fit (mm)	568	590	560 min.

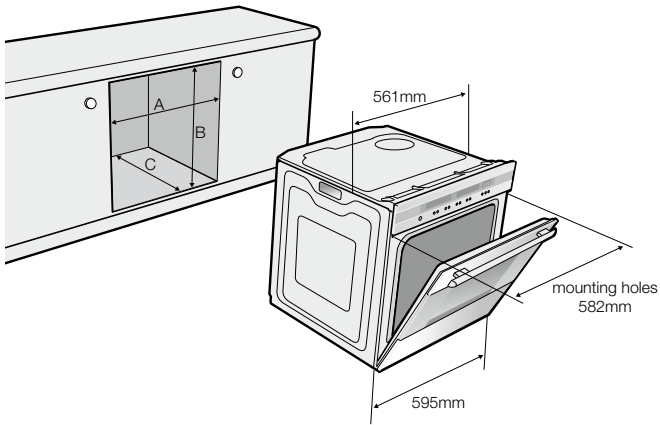

Double oven Cut-out dimensions

type of fit	A (width)	B (height)	C (depth)
Flush fit (mm)	600	1086	581 min.
Proud fit (mm)	568	1078	560 min.

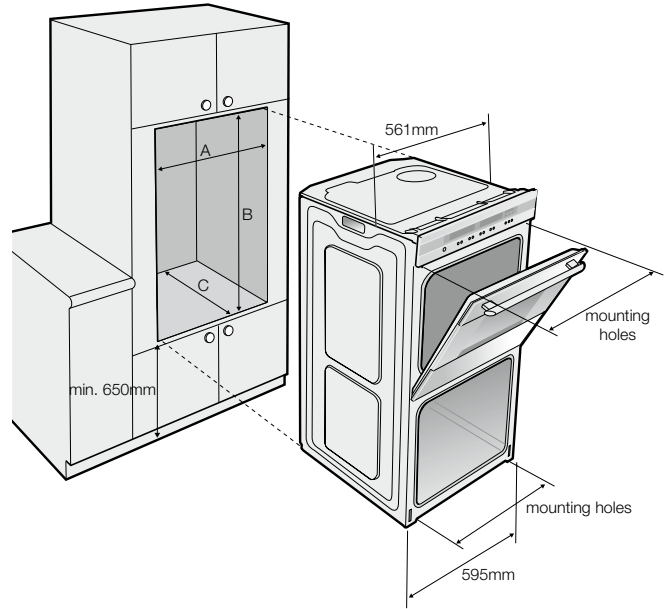

Duo oven Cut-out dimensions

type of fit	A (width)	B (height)	C (depth)
Flush fit (mm)	600	893	581 min.
Proud fit (mm)	568	885	560 min.

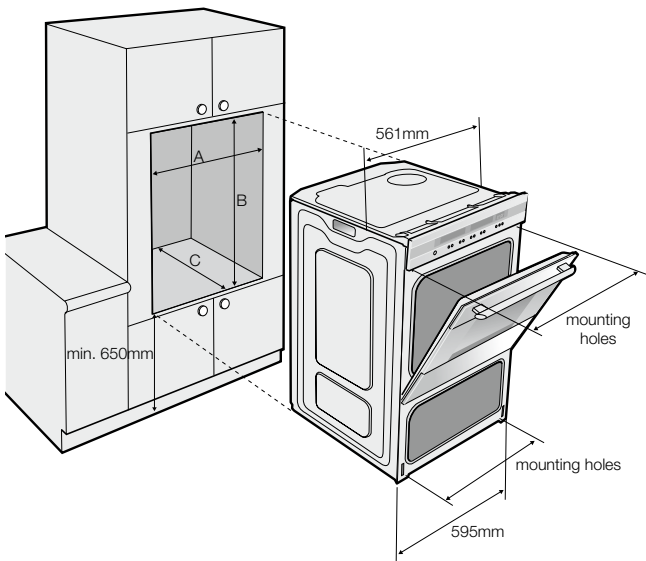

Technical specifications

model	product dimensions (h x w x d) mm	electrical connection	min. fuse rating	max. power rating	max. current rating
EOEM61AS	595 x 595 x 567	230-240v/50Hz	16A	3.1kW	12.9A
EOEE62AS	595 x 595 x 567	230-240v/50Hz	16A	3.1kW	12.9A
EOEE63AS	595 x 595 x 567	230-240v/50Hz	16A	3.1kW	12.9A
EUEE63AS	888 x 595 x 567	230-240v/50Hz	25A	5.3kW	22.1A
EDEE63AS	1081 x 595 x 567	230-240v/50Hz	25A	5.8kW	24.2A
EPEE63AS	595 x 595 x 573	230-240v/50Hz	16A	3.1kW	12.9A
EOEK62AK	595 x 595 x 567	230-240v/50Hz	16A	3.1kW	12.9A

error code	description	comment	fix
F01 or 01	Door lock sensor alarm	This relates to a door lock failure which is only associated with the Pyro product	Check wiring/plugs or replace door lock
F02 or 02	Door lock actuator alarm		
F04 or 04	Oven Probe (PT500) out of range alarm	This relates to the temperature sensing probe which may be out of tolerance, or have open/short circuit connections	Replace probe
F05 or 05	Oven Probe (PT500) too high temperature alarm		
25	Board Temperature Sensor (NTC) too high temperature alarm	This relates to the temperature of the powerboard and/or the temperature-sensing element (NTC) on the powerboard	Cooling fan not working or replace powerboard
26	Board Temperature Sensor (NTC) out of range warning		
6	Board Temperature Sensor (NTC) out of range alarm		
F08 or 08	Communication alarm	This relates to an error in communication between the powerboard and the IOI controller. This can occur if the IOI controller is connected while the powerboard is energised	Reset power. (Minimum of 20 sec.) or check or replace data cable
F09 or 09	Software compatibility code alarm	This relates to a mismatch between powerboard firmware version and the IOI controller firmware version. Most likely caused by an un-programmed powerboard	Replace Powerboard
C1	Telescopic runners fitted	Only applies to Pyro product	Remove both side racks and re-start pyro cycle
C3	Door open	Only applies to Pyro product	Close door and restart pyro cycle
F03 or 03	EEPROM check sum alarm	Relates to the controller	Replace Controller
F14 or 14	EEPROM compatibility code alarm	Relates to the controller	Replace Controller

Technical specifications

Other Potential complaints

- When the door is opened the fan stops (underbench only) This is a function of the powerboard to help reduce the blast of air the customer receives when they open the door.
- When a non-fan mode is selected the fan starts. Most oven modes have a fast heat up function that uses the fan, fan element, and top (boost) element. Auto fast heat up can be overridden by selecting a temperature of 120°C or less, allowing the function to start, then increasing the temperature to the desired level.
- The light stays on when the door is closed, does not turn on when the door is open and the oven is off. The door switch is not activating due to restricted travel or broken actuator.

Test Mode

- Within 10 seconds of powering up simultaneously press the timer button and start/stop time '+' button, this will enter 'TEST MODE' for a maximum of 5 minutes. Firstly displayed will be the software version and model No. Then using the function '∧' and '∨' buttons scroll through door lock test (Pyro only) individual element and light, cooking fan, cooling fan and temperature probe etc. functions.

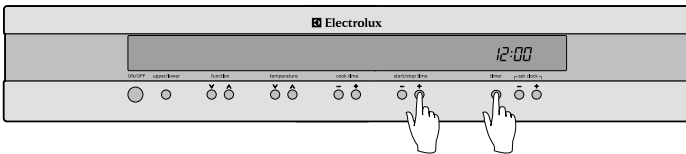

Intermittent problems

- Check for sticking buttons. Sometimes removing the control panel and re-fitting it cures this. First un-clip the control panel, remove all the buttons, refit the control panel then the buttons.

Hard wiring details

1. Remove terminal cover plate from rear panel of appliance.
2. Fit wires through hole in cover plate and make connections to terminals.
3. Engage wires into plastic clip. Secure plastic clip with two long silver screws (supplied in separate bag).
4. Replace cover plate onto rear panel.

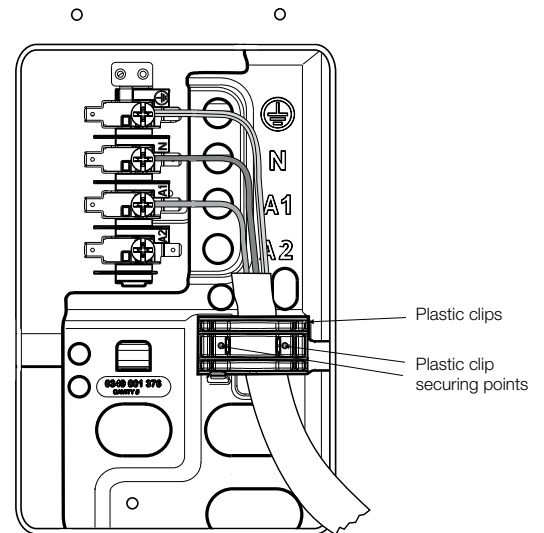

Note:

- Double oven (Model EDEE63AS)
This product is supplied with two optional termination points. Only one termination point is required to be connected.

Electrolux Warranty

FOR SALES IN AUSTRALIA AND NEW ZEALAND
APPLIANCE: ELECTROLUX E:LINE BUILT-IN OVENS

This document sets out the terms and conditions of product warranties for Electrolux branded appliances. It is an important document. Please keep it with your proof of purchase documents in a safe place for future reference should you require service for your Electrolux appliance.

General Terms and Conditions

1. In this warranty
 - (a) 'Electrolux' means Electrolux Home Products Pty Ltd ABN 51 004 762 341 in respect of Appliances purchased in Australia and Electrolux (NZ) Limited in respect of Appliances purchased in New Zealand;
 - (b) 'Appliance' means any Electrolux product purchased by you accompanied by this document;
 - (c) 'Warranty Period' means
 - (i) where you use the Appliance for personal, domestic or household purposes in Australia the period of "24" months and in New Zealand the period of "24" months;
 - (ii) where you use the Appliance for commercial purposes, in Australia the period of "3" months and in New Zealand the period of "3" months, (if the period stated is 0 months you are not covered by this product warranty) following the date of original purchase of the Appliance;
 - (d) 'you' means the purchaser of the Appliance not having purchased the appliance for re-sale, and 'your' has a corresponding meaning.
2. This warranty only applies to Appliances purchased and used in Australia or New Zealand and is in addition to (and does not exclude, restrict, or modify in any way) any non-excludable statutory warranties in Australia or New Zealand.
3. Electrolux warrants that, when dispatched from an Electrolux warehouse, the Appliance is free from defects in materials and workmanship for the Warranty Period.
4. During the Warranty Period Electrolux or its Authorised Service Centre will, at no extra charge if your appliance is readily accessible without special equipment, and subject to these terms and conditions, repair or replace any parts which it considers to be defective. You agree that any replaced Appliances or parts become the property of Electrolux. This warranty does not apply to light globes, batteries, filters or similar perishable parts.
5. Parts and Appliances not supplied by Electrolux are not covered by this warranty.
6. Where you are within an Electrolux service area, this warranty covers the cost of transport of the Appliance to and from Authorised Service Centres of Electrolux and travelling costs for representatives of the Authorised Service Centre to and from your home or business. If you are outside an Electrolux service area, you will bear these costs. For information about whether you are within an Electrolux service area, please phone 13 13 49 in Australia, or 0800 10 66 10 in New Zealand.
7. Proof of purchase is required before you can make a claim under this warranty.
8. You may not make a claim under this warranty unless the defect claimed is due to faulty or defective parts or workmanship. Electrolux is not liable in the following situations (which are not exhaustive):
 - (a) The Appliance is damaged by:
 - (i) accident
 - (ii) misuse or abuse, including failure to properly maintain or service
 - (iii) normal wear and tear
 - (iv) power surges, electrical storm damage or incorrect power supply
 - (v) incomplete or improper installation
 - (vi) incorrect, improper or inappropriate operation
 - (vii) insect or vermin infestation.

- (b) The Appliance is modified without authority from Electrolux in writing.
 - (c) The Appliance's serial number or warranty seal has been removed or defaced.
 - (d) The Appliance was serviced or repaired by anyone other than Electrolux or its Authorised Service Centres.
9. This warranty, the contract to which it relates and the relationship between you and Electrolux are governed by the law applicable in the Australian State where the Appliance was purchased or the law applicable in New Zealand if the Appliance was purchased in New Zealand. Where the Appliance was purchased in New Zealand for business purposes the Consumer Guarantee Act does not apply.

Limitation of Liability

10. To the extent permitted by law:
 - (a) Electrolux excludes all warranties other than as contained in this document;
 - (b) Electrolux shall not be liable for any loss or damage whether direct or indirect or consequential arising from your purchase, use or non-use of the Appliance.
11. Provisions of the Trade Practices Act and State consumer legislation in Australia, and the Consumer Guarantees Act, the Sale of Goods Act and the Fair Trading Act in New Zealand, imply warranties or conditions, or impose obligations, upon Electrolux which cannot be excluded, restricted or modified. To the extent permitted by law, the liability of Electrolux (if any) arising out of or in relation to the Appliance or any services supplied by Electrolux shall be limited (where it is fair and reasonable to do so):
 - (a) in the case of Appliances, at its option, to the replacement or repair of the Appliances or the supply of equivalent products or the payment of the cost of replacing the Appliances or having the Appliances repaired or of acquiring equivalent Appliances. Upon being replaced, parts and Appliances become the property of Electrolux; or
 - (b) in the case of services, at its option, to the supply of the services again or the payment of the cost of having the services re-supplied;
 and in the case of Appliances or services supplied in New Zealand, loss or damage whether direct or indirect or consequential that is reasonably foreseeable.

Privacy

You acknowledge that in the event that you make a warranty claim it will be necessary for Electrolux and its Authorised Service Centres to exchange information in relation to you to enable Electrolux to meet its obligations under this warranty.

Important Notice

Before Calling a Service Technician please check carefully the operating instructions, service booklet and the warranty terms and conditions.

<p>FOR SERVICE or to find the address of your nearest state service centre in Australia PLEASE CALL 13 13 49 For the cost of a local call (Australia only)</p>	<p>SERVICE AUSTRALIA  ELECTROLUX HOME PRODUCTS</p>	<p>FOR SPARE PARTS or to find the address of your nearest state spare parts centre in Australia PLEASE CALL 13 13 50 For the cost of a local call (Australia only)</p>
<p>FOR SERVICE or to find the address of your nearest authorised service centre in New Zealand FREE CALL 0800 10 66 10 (New Zealand only)</p>	<p>NEW ZEALAND SPARE PARTS CENTRES AUCKLAND Prime Distributors Ltd. 8 Highbrook Drive, East Tamaki (09) 273 3580 CHRISTCHURCH Prime Distributors Ltd. Unit 1, 127 Montreal Street (03) 375 4095 R. Redpath Ltd. 55 Ferry Road (03) 075 0429 DUNEDIN Appliance Parts Company, 590 Hillside Road (03) 455 5443  Electrolux ELECTROLUX HOME PRODUCTS</p> <div style="text-align: right;">  Australia's largest online appliance retailer </div>	



Electrolux Home Products Australia

telephone: 1300 363 640

fax: 1800 350 067

email: customercare@electrolux.com.au

web: www.electrolux.com.au

The Thoughtful Design Innovator.

Do you remember the last time you opened a gift that made you say, "Oh! How did you know? That's exactly what I wanted!" That's the kind of feeling that we at Electrolux seek to evoke in everyone who chooses or uses one of our products. We devote time, knowledge, and a great deal of thought to anticipating and creating the kind of appliances that our customers really need and want.

This kind of thoughtful care means innovating with insight. Not design for design's sake, but design for the user's sake. For us, thoughtful design means making appliances easier to use and tasks more enjoyable to perform, freeing our customers to experience the ultimate 21st century luxury: ease of mind. Our aim is to make this ease of mind more available to more people in more parts of their everyday lives, all over the world.

The "Thinking of you" promise from Electrolux goes beyond meeting the needs of today's consumers. It also means we're committed to making appliances safe for the environment – now and for future generations.

Electrolux. Thinking of you.

Share more of our thinking at www.electrolux.com.au