



# Russell Hobbs



## **COOK@HOME 3.2L DEEP FRYER**

2 YEAR WARRANTY

**RHDF320**

RHDF320\_IB&RB\_FA\_170820  
Part no. T22-9001961

### INSTRUCTIONS & WARRANTY



## IMPORTANT SAFEGUARDS

When using electrical appliances, basic safety precautions should always be followed, including but not limited to the following:

1. To protect against electrical hazards do not immerse the power cord, plug or appliance in water or any other liquid.
2. Do not use in the bathroom or near any source of water. Do not use outdoors. 
3. Always use the appliances handles as some parts will be hot.
4. The temperature of accessible surfaces/parts may become very hot when the appliance is operating and are subject to residual heat for some time after the appliance has been switched off.
5. This appliance is not intended for use by persons (including children) with reduced physical, sensory or mental capabilities, or lack of experience and knowledge, unless they have been given supervision or instruction concerning use of the appliance by a person responsible for their safety.
6. Unplug the appliance when not in use, before moving and before cleaning, let it cool down fully before cleaning or storing away.
7. Do not operate this appliance with a damaged cord/plug or after the appliance has malfunctioned, or been dropped or damaged in any manner. Contact Customer service for replacement, examination, repair or adjustment.
8. There are no serviceable parts. If the power cord or appliance is damaged, it must be replaced by the manufacturer or similarly qualified person in order to avoid a hazard.
9. Do not use on an inclined plane or unstable surface.
10. Do not move the appliance when in use.
11. Do not cover the appliance when in use.
12. Do not cook food items too large for the appliance.
13. Take care when opening the lid of the appliance, as hot oil can spatter and there may be some steam.
14. Always take care when removing food after cooking as it is hot.
15. Do not use the appliance near or below any curtains or other combustible materials.
16. Keep the appliance and the power cord away from the edge of tables or countertops and out of reach of children and persons with disabilities.
17. To disconnect, turn off the wall power outlet, then grasp the plug and remove from wall power socket. Never pull by the cord.
18. Always clean the appliance after use.
19. Do not place on or near any heat sources.
20. Do not leave the appliance unattended when in use.
21. Follow the instructions when cleaning this appliance.
22. Do not use appliance for other than its intended purpose.
23. This appliance is not a toy. Children should be supervised to ensure they do not play with the appliance.
24. Cleaning and user maintenance shall not be made by children without supervision.
25. Do not use the fryer without first filling with good quality cooking oil between the MIN and MAX marks inside the bowl. If the oil level is below the MIN mark, you may damage the fryer. If above the MAX mark, hot oil may escape, causing damage and injury.
26. Do not try to move or carry the fryer if it contains hot oil. Let it cool down fully first.
27. Do not lean or reach over the fryer while the oil is hot.

28. Do not carry or pass anything through the space over or near the fryer- if anything drops into the fryer, hot oil will splash out.
29. This appliance is not intended to be operated by means of an external timer or separate remote control system.
30. For added safety, electrical appliances should be connected to a power outlet that is protected by a residual current device (RCD), also often referred to as a 'Safety Switch'. Your switchboard may already incorporate an RCD. If unsure, call an electrician for verification and fitting if necessary.

This appliance is intended to be used in household and similar applications such as:

- Staff kitchen areas in shops, offices and other working environments;
- Farm houses;
- By clients in hotels, motels, and other residential type environments;
- Bed & breakfast type environments.



**CAUTION: Hot Surface(s).** This symbol indicates that surfaces of the appliance may be hot and care should be taken to avoid possible burns.

**SAVE THESE INSTRUCTIONS**

Congratulations on the purchase of your new Russell Hobbs COOK@HOME Deep Fryer. Each unit is manufactured to ensure safety and reliability. **Before using the Deep Fryer for the first time, please read this instruction booklet carefully and keep it for future reference. Pass it on if you pass on the Deep Fryer.**

When using this appliance, basic safety precautions should always be followed.



CAUTION: Hot surfaces

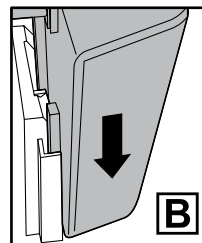
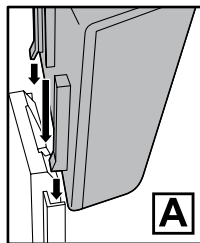
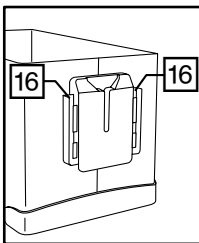
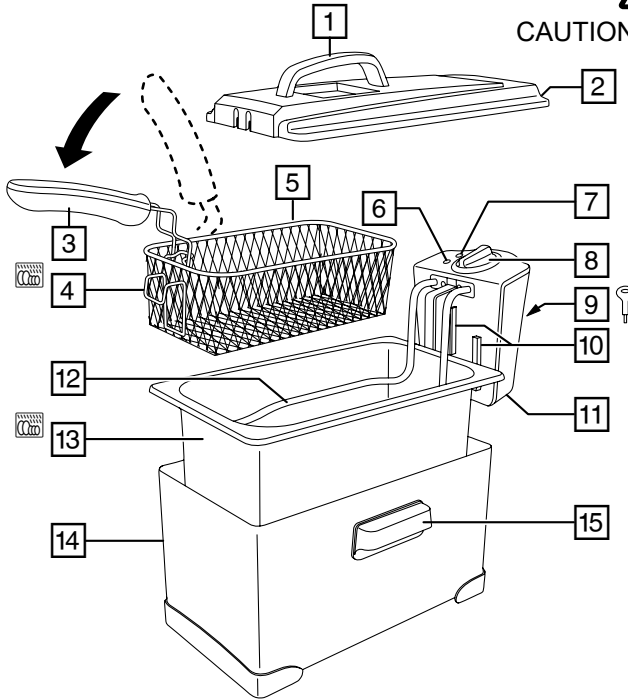

## FEATURES

- |                |                          |                      |
|----------------|--------------------------|----------------------|
| 1. Lid handle  | 7. Heating light         | 13. Bowl             |
| 2. Lid         | 8. Temperature control   | 14. Body             |
| 3. Handle      | 9. Reset button          | 15. Carrying handles |
| 4. Basket rest | 10. Guides               | 16. Grooves          |
| 5. Basket      | 11. Heating/control unit |                      |
| 6. Power light | 12. Element              |                      |

## PREPARATION

1. Sit the appliance on a stable, level, heat-resistant surface.
2. Leave a space of at least 100mm all round the appliance.
3. Position the appliance so that the basket handle doesn't extend up to or over the edge of the work surface, where it is likely to be caught accidentally when passing.
4. Unfold the basket handle and push the uprights over the latch above the hinge.
5. Line a colander with paper towels, to drain the food after it's cooked.

## ASSEMBLY

1. Lower the bowl into the body of the fryer.
2. Engage the grooves on the control unit with the guides on the rear of the body (FIG. A), and slide the control unit into place (FIG. B).

**If the control unit isn't fitted correctly, a safety switch on the unit will prevent the fryer from working.**

3. Put the basket inside the bowl.

## FILLING

1. Fill the bowl with good quality liquid cooking oil to between the MIN (2.7 litres) and MAX (3,2 litres) marks on the side of the bowl.
2. Don't use solid cooking oil, fat, butter or margarine.
3. Don't mix oils of different types, as they will have different temperature characteristics.
4. Replace the lid.

## FOOD PREPARATION

1. Cut food into uniformly sized pieces.
2. Coat wet foods (e.g. fish, pineapple) with flour, breadcrumbs, batter, etc.
3. Don't use the appliance to defrost food. Any food other than pre-cooked, quick-frozen foods must be fully defrosted before putting into the appliance.
4. When cooking pre-packed foods, follow any guidelines on the package or label.
5. When cooking raw vegetables (e.g. potato chips or slices), dry the pieces off with paper towel or a tea towel.

## USING YOUR FRYER

1. Set the temperature control to the required temperature (130-190°C).
2. Put the plug into the power socket.
3. The power light will come on as long as the appliance is connected to the electricity supply.
4. The heating light will come on, then cycle on and off as the thermostat maintains the temperature.
5. Wait till the light goes out before cooking.
6. Put the prepared food pieces in the basket.
7. Try not to put more than two layers of food in the basket. If you need to cook more, do it in batches.
8. Using an oven glove, hold the basket by the handle and lower the basket slowly and gently into the oil.
9. The oil will foam as it comes into contact with water from the food. As long as the foam doesn't threaten to overflow the bowl, this should not be a cause for alarm.
10. If the foam threatens to overflow the bowl, remove the basket, set it back on the paper towels, then check the "problems" section.
11. Wait till the food has cooked.
12. Check it's cooked. If you're in doubt, cook it a bit more.
13. Using an oven glove, lift the basket by the handle, hook the basket rest over the rim of the bowl, and let it drain.
14. Empty the food into the colander, to drain further before serving.
15. Return the empty basket to the rim of the bowl.
16. If you want to cook another batch of food, check the oil level and top up as necessary.
17. Once finished, unplug the appliance.

## HINTS AND TIPS

- Adding food to the oil reduces the temperature of the oil.
- If you add a small amount of food, the temperature will recover quickly, and the food will be cooked properly.
- When you put food into the appliance, you should see bubbles forming.
- This is steam, formed when the moisture inside the food heats up. The steam coming out of the food prevents oil from soaking into the food.
- The food cooks uniformly – firm and crisp.
- If you add too much food, the temperature will not recover, and your food will absorb oil.

## FROZEN FOOD

- Frozen food cools oil quickly, so fry a single layer at a time.
- Shake off excess ice or water before adding the food to the oil.
- Keep the pieces apart, or they'll stick together.
- Use the highest temperature setting, and lower the basket slowly into the oil to reduce foaming.
- When cooking pre-packed foods, follow any guidelines on the package or label.

### Fish – frozen

You may fry pre-coated fish – follow the directions on the package.

Type	Temperature (°C)	Time (mins)
Fillets	170	10-15
Goujons	190	3
Fish cakes - small	170	3
Fish cakes - medium/large	170	4-5
Whitebait	190	2-3

### Fish – fresh

Fish has a high water content. Dry with paper towel, and coat before frying. Use whole, or cut into fillets, cutlets or goujons.

Type	Temperature (°C)	Time (mins)
Fillets, goujons, fish cakes	190	3-4
Whitebait	190	1-2

### Meat

Only deep fry fresh/thawed meat. Coat in egg and breadcrumbs or batter. For frozen meat products, follow directions on the package.

Type	Temperature (°C)	Time (mins)
Goujons	190	3
Chops/cutlets - small/large	170	10/15
Scotch eggs	170	10
Rissoles, meat balls	190	6
Wiener schnitzel (depending on thickness)	170	3-8

## Poultry

Only deep fry fresh or thawed poultry. Coat in egg and breadcrumbs or batter. Remove the skin for better results. Allow time for poultry to cook to the centre. A crisp golden exterior doesn't necessarily denote this, so test before serving. For frozen poultry product, follow directions on the package.

Type	Temperature (°C)	Time (mins)
Goujons	170	4
Drumsticks	170	14-15
Croquettes	190	2-3
Chicken in breadcrumbs - small	170	15-20
Chicken in breadcrumbs - large	170	20-30

## Bread, cakes, fritters

Type	Temperature (°C)	Time (mins)
Doughnuts	190	2
Pineapple, banana or apple fritters	190	2-3
Croutons (diced bread)	190	1

## PROBLEMS

- If the oil foams and threatens to overflow, there's too much food in the basket (take some out), the food is too moist (dry it a bit and try again), or the oil is old or contaminated (replace it).
- Every time oil is heated, it deteriorates.
- Every time food is put into oil, moisture, particles of food and fat, flour and spices from coatings, water from frozen foods, cause further deterioration.
- Particles blacken, burn, and stick to the next batch of food, altering its look and taste. Filtering can alleviate this a bit.
- Even filtered oil will be past its best after 10 to 12 uses.
- Pre-cooked and oven chips have a coating of oil from the pre-cooking process. This will thicken or discolour the oil in your fryer.
- If you cook coated foods regularly, it might be worth keeping two lots of oil, one for coated foods and one for "oil-friendly" foods.
- As a rough guide, if you notice an improvement in flavour after changing the oil, you should change it more often.
- Your Local Authority will have a depot where old oil can be taken for recycling or environmentally friendly disposal.
- Ensure the oil level always remains above the Min mark of the oil level window.
- The lid should be kept on at all times during frying.
- Arrange food in a single layer.
- Uniformly cut foods will for better frying results more evenly.
- You'll need to experiment to find the times which suit your favourite foods and food combinations.

## **THERMAL CUT-OUT**

The cut-out operates to protect the element from overheating.

If your fryer stops working:

1. Switch off, unplug, and let it cool down.
2. Check the oil level.
3. If the oil level is below the MIN mark, reset the cut-out.
4. If the oil level isn't too low, and the cut-out has operated for some other reason, ring Customer Service.
5. Press the reset button and reset the cut-out.
6. The excess heat will have spoiled the oil, so clean out the bowl and refill with fresh oil.

## CARE AND MAINTENANCE

Unplug the appliance and let it cool down before cleaning or storing away.

### Normal cleaning

1. Wipe outer surfaces with a damp cloth.
2. Put the lid on top of the bowl, to keep dust, etc. out of the oil.

### Full cleaning (after every few uses)

- Cover the work surface with at least 3 layers of paper towel.
  - You'll need a 5 litre container and a wide necked funnel.
  - If you want to filter the oil, use a sieve lined with muslin or filter paper.
1. Remove the lid and basket.
  2. Lift the heating/control unit off.
  3. Using the funnel, pour the oil into the 5 litre container.
  4. Clean the heating/control unit with a clean damp cloth.
  5. Wash the body, lid, basket, and bowl in warm soapy water and dry thoroughly.
  6. Replace the body and heating unit in the bowl.
  7. Place the basket inside the body.
  8. Push the basket handle forward, and swing the handle down into the basket.
  9. Replace the lid.

 You may wash these parts in a dishwasher.

- If you use a dishwasher, the harsh environment inside the dishwasher will affect the surface finishes.
- The damage should be cosmetic only, and should not affect the operation of the appliance.
- If residue builds up on the element, clean it with detergent, and clean more often.
- Remove all trace of detergent and dry before reassembling.

### Discolouration

With use, the basket, element, thermostats, and control wires will discolour. This is inevitable, harmless, and won't affect the operation of the appliance.

Legislation in some localities mandates that e-waste (anything with a plug, battery or cord) is disposed of through controlled recycling facilities and must not be disposed of in general household waste. For more information about recycling of electrical and battery operated appliances, please contact your local council or your local household waste disposal service.

**Spectrum Brands Australia Pty Ltd**

Locked Bag 3004 Braeside  
Victoria 3195 Australia

**Customer Service in Australia**

TollFree: 1800 623 118  
Email: info@spectrumbrands.com.au  
Website: www.spectrumbrands.com.au

**Spectrum Brands New Zealand Ltd**

PO Box 9817 Newmarket  
Auckland 1149 New Zealand

**Customer Service in New Zealand**

TollFree: 0800 736 776  
Email: service@spectrumbrands.co.nz  
Website: www.spectrumbrands.co.nz

## **Spectrum Brands Australia Pty Ltd and Spectrum Brands New Zealand Ltd Warranty Against Defects**

In this warranty:

**Australian Consumer Law** means the Australian consumer law set out in Schedule 2 to the Competition and Consumer Act 2010;

**CGA** means the New Zealand Consumer Guarantees Act 1993;

**Goods** means the product or equipment which was accompanied by this warranty and purchased in Australia or New Zealand, as the case may be;

**Manufacturer, We or us** means:

1. for Goods purchased in Australia, Spectrum Brands Australia Pty Ltd ABN, 78 007 070 573;  
or
2. for Goods purchased in New Zealand, Spectrum Brands New Zealand Ltd, as the case may be, contact details as set out at the end of this warranty;

**Supplier** means the authorised distributor or retailer of the Goods that sold you the Goods in Australia or in New Zealand; and

**You** means you, the original end-user purchaser of the Goods.

1. Our goods come with guarantees that cannot be excluded under the Australian Consumer Law, or the CGA. You are entitled to a replacement or refund for a major failure and compensation for any other reasonably foreseeable loss or damage. You are also entitled to have the goods repaired or replaced if the goods fail to be of acceptable quality and the failure does not amount to a major failure.
2. The benefits provided by this Warranty are in addition to all other rights and remedies in respect of the Goods which the consumer has under either the Australian Consumer Law or the CGA. The original purchaser of the Goods is provided with the following Warranty subject to the Warranty Conditions:
3. We warrant the Goods for all parts defective in workmanship or materials for a (**Warranty Period**) period of 2 years from the date of purchase.

If the Goods prove defective within the Warranty Period by reason of improper workmanship or material, we may, at our own discretion, repair or replace the Goods without charge.

## Warranty Conditions

4. The Goods must be used in accordance with the manufacturer's instructions. This Warranty does not apply should the defect in or failure of the Goods be attributable to misuse, abuse, accident or non-observance of manufacturer's instructions on the part of the user. As far as the law permits, the manufacturer does not accept liability for any direct or consequential loss, damage or other expense caused by or arising out of any failure to use the Goods in accordance with the manufacturer's instructions.
  5. Exhaustible components (such as batteries, filters and brushes) of the Goods are included under this Warranty only where there is a defect in workmanship or materials used.
  6. The warranty granted under clause 3 is limited to repair or replacement only.
  7. Any parts of the Goods replaced during repairs or any product replaced remain the property of the manufacturer. In the event of the Goods being replaced during the Warranty Period, the warranty on the replacement Goods will expire on the same date as for the Warranty Period on the original Goods which are replaced.
  8. In order to claim under the warranty granted under clause 3 you must:
    - (a) Retain this warranty with your receipt/proof of purchase; and
    - (b) Return the Goods to us at the relevant address or to the Supplier by prepaid freight within the Warranty Period accompanied with (i) the legible and unmodified original proof of purchase, which clearly indicates the name and address of the Supplier, the date and place of purchase, the product name or other product serial number and (ii) this warranty.
  9. This warranty is immediately void if:
    - (a) Any serial number or appliance plate is removed or defaced;
    - (b) The Goods have been serviced or otherwise repaired by a person not authorised to do so by us or where non approved replaced parts are used.
  10. The Goods are designed for domestic use only. The Goods must be connected to the electrical voltage requirements as specified in the ratings label located on the Goods.
  11. This warranty does not cover the cost of claiming under the warranty or transport of the Goods to and from the Supplier or us.
  12. This warranty is only valid and enforceable in Australia against Spectrum Brands Australia Pty Ltd and in New Zealand against Spectrum Brands New Zealand Ltd.
- Contact us or the Supplier for further details.

## Register your product online

If you live in Australia please visit: [www.spectrumbrands.com.au/warranty](http://www.spectrumbrands.com.au/warranty)

If you live in New Zealand Please visit: [www.spectrumbrands.co.nz/warranty](http://www.spectrumbrands.co.nz/warranty)

Registration of your warranty is not compulsory, it gives us a record of your purchase AND entitles you to receive these benefits: Product information; Hints and tips; Recipes and news; Information on special price offers and promotions.

**Any questions?** Please contact Customer Service for advice.





# Russell Hobbs



## **COOK@HOME 3.2L DEEP FRYER**

2 YEAR WARRANTY

**RHDF320**

RHDF320\_IB&RB\_FA\_170820  
Part no. T22-9001961

**RECIPE BOOK**



## COATINGS AND BATTERS

Coat all foods, except those high in starch, like potatoes and doughnuts. The coating protects the food, helps prevent juices leaking into the oil, and gives a crisp, tasty result. Generally, coatings won't stick to frozen foods.

### SEASONED FLOUR

Thicker coatings don't stick well to wet/damp foods, so coat them first in seasoned flour. Use on its own to coat small whole oily fish like whitebait.

### EGG AND BREADCRUMBS

Popular on fish, chicken, and scotch eggs, it gives an attractive, crisp, crunchy exterior. Ideal for foods that are to be served cold, as it stays crisp for hours.

1. Coat in seasoned flour, to dry the food. Dip in beaten egg, then breadcrumbs, repeat till fully coated, press well, then shake off any excess.
2. Fresh breadcrumbs give a rough appearance. Make dry breadcrumbs or raspings by baking scraps of bread till golden, then crush or process to a fine crumb.

### BASIC BATTER

#### Ingredients:

- 100g self raising flour
- 1 pinch salt
- Water

#### Method:

Sift the flour into a bowl. Add the salt. Just before it's needed, stir in enough water to form a smooth batter.

### BASIC FRITTER BATTER

#### Ingredients:

- 100g self raising flour
- 5ml vegetable oil
- 1 pinch salt
- Water

#### Method:

Sift the flour into a bowl. Add the salt. Beat in the oil. Just before it's needed, stir in enough water to form a smooth batter.

[www.russellhobbs.com.au](http://www.russellhobbs.com.au)

[www.russellhobbs.co.nz](http://www.russellhobbs.co.nz)

RUSSELL HOBBS and logo are Trade Marks of Spectrum Brands, Inc., or one of its subsidiaries.  
©2020 Spectrum Brands, Inc.

Recipes are to be used in conjunction with the RHDF320 Cook@Home 3.2L Deep Fryer by Russell Hobbs. All rights reserved. No part of this publication may be reproduced, stored in a retrieval system or transmitted in any form or by any means, electronic, mechanical, photocopying, recording or otherwise, without prior permission of the copyright owner.

## **FRITTER BATTER WITH EGG WHITE**

### **Ingredients:**

- 100g plain flour
- 150ml liquid
- 15ml vegetable oil
- 1 pinch salt
- 1 egg

### **Method:**

The liquid can be water, milk, beer, sparkling water, etc.

Separate the egg. Sift the flour into a bowl. Add the salt. Stir in the egg yolk, then the liquid. Beat in the oil. Just before it's needed, whisk the egg white and fold into the batter.

## **CRISPY CHINESE BATTER**

### **Ingredients:**

- 75g cornflour
- 5ml vegetable oil
- 10g baking powder
- 1 egg
- 1 pinch salt
- Water

### **Method:**

Mix the egg, cornflour, salt and oil with enough cold water to form a creamy base on which to add either egg and breadcrumbs or batter.

## **FRYING TIMES**

Use these times purely as a guide.

Cook meat, poultry, and derivatives (mince, burgers, etc.) till the juices run clear. Cook fish till the flesh is opaque throughout. Chips (french fries) and other vegetables should be crisp.

## **CHIPS (FRENCH FRIES)**

- Peel, cut, rinse, drain, and dry thoroughly. Don't put more than two layers of chips in the basket at a time. For best results, cook the potatoes in two stages:

### **Method:**

Stage 1 – fry for 5-10 minutes (depending on quantity) at 170°C. When the chips reach pale gold, and the outside is firm, lift the basket out of the oil, and leave the chips to drain and cool

Stage 2 – fry for 2-4 minutes at 190°C. When golden brown and crisp, remove from the oil, and drain in a colander lined with paper towels.

## **FROZEN CHIPS (FRENCH FRIES)**

Follow the instructions on the package.

## **OTHER VEGETABLES**

Many vegetables may be deep fried – onion rings, mushrooms, cauliflower florets. They can be cooked from fresh or frozen, and should be coated.