

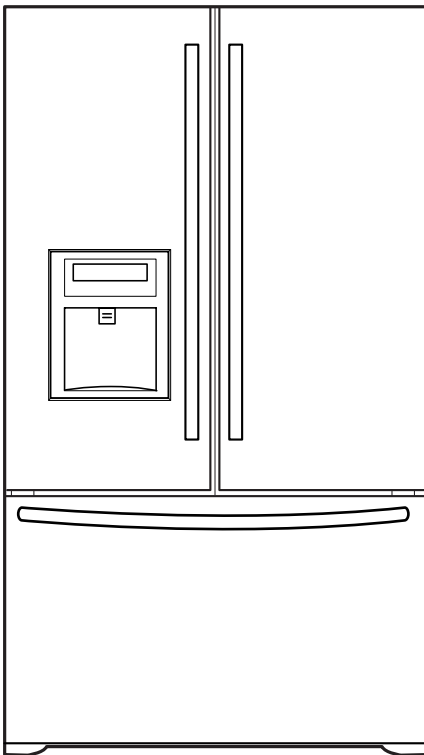

REFRIGERATOR

SERVICE MANUAL

CAUTION
BEFORE SERVICING THE UNIT,
READ THE SAFETY PRECAUTIONS IN THIS MANUAL.



Model #s:

795.77562600
795.77569600
795.77564600
795.77563600
795.77572600
795.77579600
795.77573600

CONTENTS

Safety Precautions

1. Specification	
2. Parts Identification	
3. Operation	
3-1. Explanation of Each Function	
3-2. Ice Maker Function.....	
4. Wiring Diagram	
5. Adjustment	
5-1. Compressor.....	
5-2. Positive Temperature Coefficient (PTC) – Starter	
5-3. Over Load Protector (OLP)	
5-4. Remove the cover Positive Temperature Coefficient (PTC)	
6. Troubleshooting	
6-1. Error Mode Summary	
6-2. Troubleshooting With Error	
6-3. Troubleshooting Else	
7. Component Testing Information	
7-1. Defrost Controller Assembly	
7-2. Sheath Heater	
7-3. Door Heater Assembly	
7-4. Switch (F, R).....	
7-5. Solenoid	
7-6. AC Motor Assembly	
7-7. Damper	
7-8. Lamp Socket	
8. Disassembly Instructions	
9. PCB Assembly	
10. Exploded View	

SAFETY PRECAUTIONS

Please read the following instructions before servicing your refrigerator.

1. Unplug the power before handling any electrical components.
2. Check the rated current, voltage, and capacity.
3. Take caution not to get water near any electrical components.
4. Use exact replacement parts.
5. Remove any objects from the top prior to tilting the product.



1. SPECIFICATIONS

1-1 DISCONNECT POWER CORD BEFORE SERVICING IMPORTANT – RECONNECT ALL GROUNDING DEVICES

All parts of this appliance capable of conducting electrical current are grounded. If grounding wires, screws, straps, clips, nuts or washers used to complete a path to ground are removed for service, they must be returned to their original position and properly fastened.

1-2 IMPORTANT NOTICE

This information is intended for use by individuals possessing adequate backgrounds of electrical, electronic and mechanical experience. Any attempt to repair a major appliance may result in personal injury and property damage. The manufacturer or seller cannot be responsible for the interpretation of this information, nor can it assume any liability in connection with its use.

1-3 ELECTRICAL SPECIFICATIONS

Temperature Control (Freezer Compartment) ...-6°F to +8°F
 Defrost Control Total Comp Running Time 7 hrs
 Defrost Thermostat 46°F
 Electrical Rating : 115VAC, 60Hz 1-5 A
 Maximum Current Leakage 0.5 mA
 Maximum Ground Path Resistance 0.14 Ohms
 Energy Consumption 25 cu.ft. 579 kWh/yr (Energy Star)

1-4 NO LOAD PERFORMANCE CONTROL POSITION: MID/MID

And Ambient of: 70°F 90°F
 Fresh Food, °F 33°F to 41°F 33°F to 41°F
 Frozen Food, °F -4°F to +4°F -4°F to +4°F
 Percent Running Time 35%-45% 50°F-70°F

1-5 REFRIGERATION SYSTEM

Minimum Compressor Capacity Vacuum 21 MIN.
 Minimum Equalized Pressure
 @ 70°F 49 PSIG
 @ 90°F 56 PSIG
 Refrigerant R134a 4.41 oz.
 Compressor 956 BTU/hr

1-6 INSTALLATION

Clearance must be provided at top, sides and rear of the refrigerator for air circulation.

AT TOP 2 in
 AT SIDES 1 in
 AT REAR 1 in

1-7 REPLACEMENT PARTS

Relay.....	6748C-0004D
Overload	6750C-0004R
Defrost Thermostat.....	6615JB2005H
Defrost Heater	5300JK1005D
Evaporator Fan Motor.....	4681JK1004E
Capacitor (Running)	0CZZJB2014B
	*0CZZJB2012H
	*0CZZJB2012K
Compressor (Hi-Side)	TCA31748001
Evaporator (Lo-Side).....	5421JJ1007A
Condenser.....	5403JJ1004B
Dryer.....	5851JA2002P
Condenser Fan Motor	4681JB1029D
Temperature Control	3551JA1132L(SW)
	3551JA1132M(ST)
	3551JA1132N(WB)
	3551JA1132P(BI)
Main Control.....	EBR3491102
Ice Fan Motor	4681JB1029E
	*OPTIONAL

1-8 AIR FLOW / CIRCULATION D'AIR

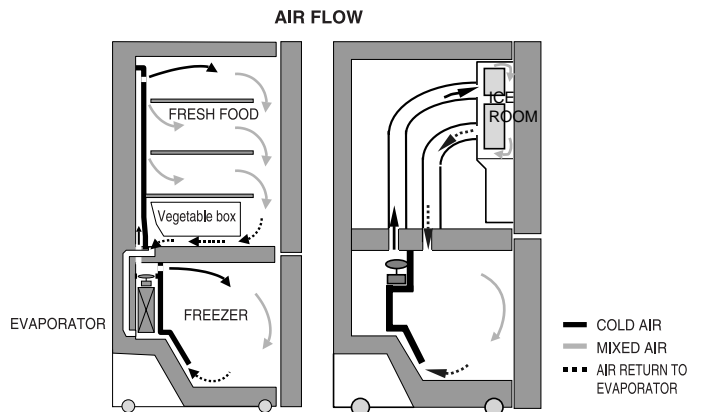
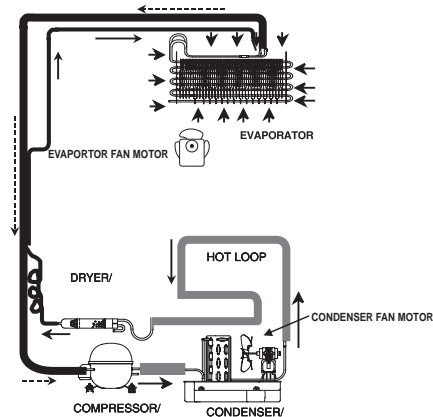

2. PARTS IDENTIFICATION

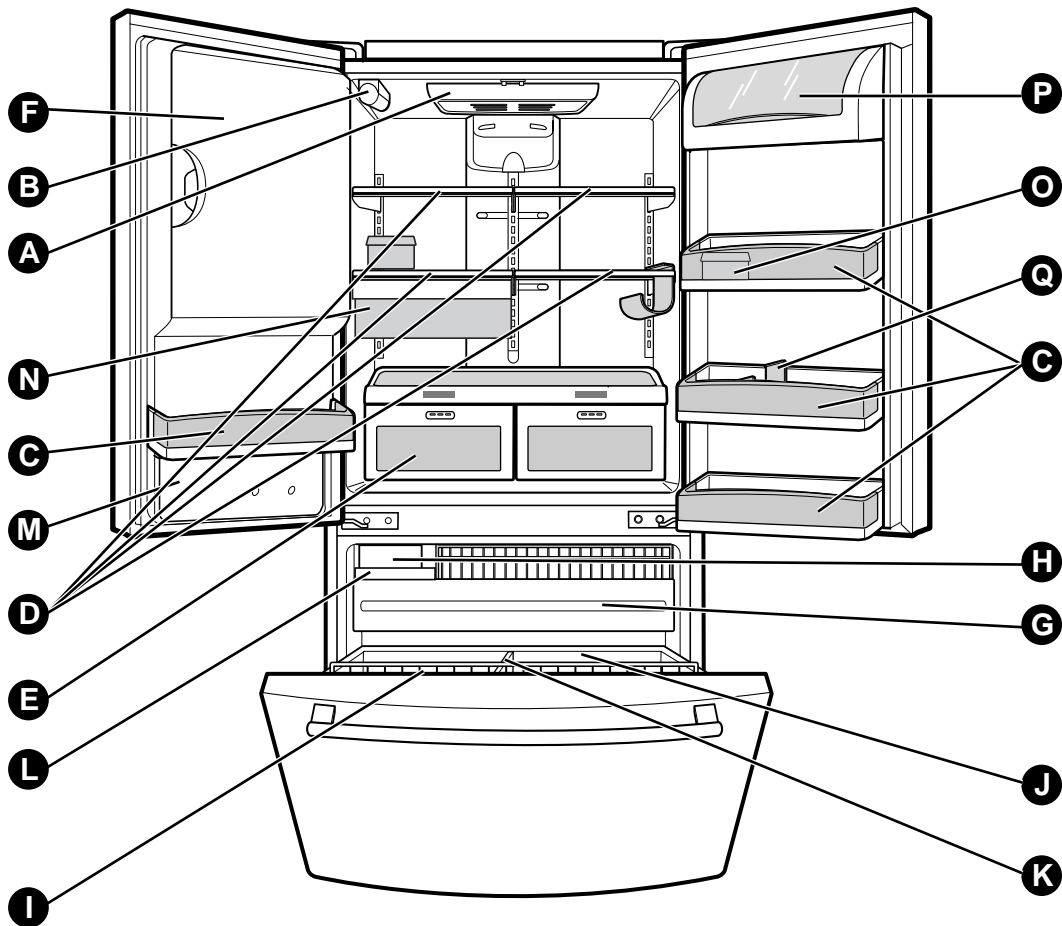

- A** Refrigerator Light
- B** Filter (Inside)
- C** Modular Door Bins
- D** Refrigerator Shelves
- E** Supra Fresh Crisper with Tilt-Out Compartment
- F** Ice Room (ICEMAKER and ICE BIN)
- G** Pull out Drawer
- H** Turbo Motor

- I** Tilt-Out Door Basket
- J** Durabase
- K** Divider
- L** Ice Bin
- M** Water Tank Cover
- N** Snack Pan
- O** Egg Box
- P** Dairy Bin
- Q** Bottle Holder

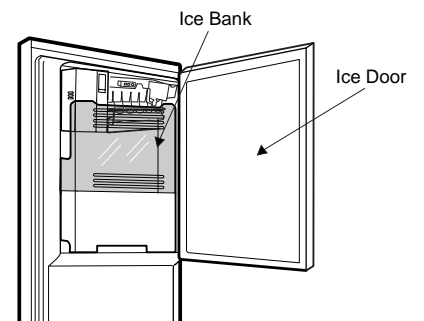

3. OPERATION

3-1. Explanation Of Each Function

1. Function

- (1) When the appliance is plugged in, it is set to 37 °F for the refrigerator and 0 °F for the freezer.
You can adjust the refrigerator and the freezer control temperature by pressing the ADJUST button.
- (2) When the power is initially applied or restored after a power failure, maintains its previously set temperature.

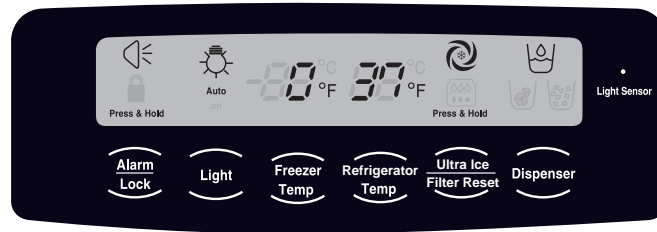

2 How to Toggle the Display between °F and °C

- (1) The initial setting is °F and the display temperature mode can be changed from °F to °ΔC or °ΔC to °ΔF by pressing and holding the FRZ TEMP and the REF TEMP keys at the same time for over 5 seconds.

3. Lock function (dispenser and display button lock)

- (1) When the refrigerator is first turned on, the buttons are not locked. The display panel shows the padlock unlocked icon.
- (2) To lock the display, the dispenser, and the control panel, press and hold the LOCK button for 3 seconds. The locked pad lock icon is displayed.
- (3) The LOCK button is the only control feature that remains active in the locked state. The buzzer sound, other control buttons, and the dispenser are deactivated.
- (4) To release from the locked state, press and hold the LOCK button again for 3 seconds.

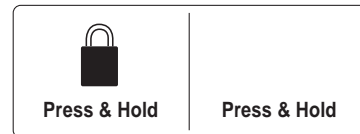

Ex) In selecting "LOCK"

Ex) In selecting "LOCK" again

4. Filter condition display function

- (1) There is a replacement indicator icon for the filter cartridge on the dispenser.
- (2) The water filter should be replaced approximately every six months.
- (3) The water filter icon will turn on every six months to remind you to replace.
- (4) After replacing the filter, press and hold the lock button more than 3 seconds.
This will turn off the reminder icon and reset the timer.

Classification	In initial Power On / Filter RESET	Replace indicator light on
	Filter Status Display	
	Press & Hold	Press & Hold

5. Ice Plus Selection

Please select this function for quick freezing.

- (1) The ICE PLUS option starts counting its 24-hours period every time the button is pressed.
- (2) The ICE PLUS function automatically turns off after twenty-four hours pass.



6. Dispenser Use Selection

You can select water or ice.

- * Select water, crushed ice, or ice cubes by cycling through the selections when pressing the DISPENSER button,
- * Hold your cup in the dispenser for a few seconds after dispensing ice or water to allow the last pieces of ice or drops of water to fall into the cup.

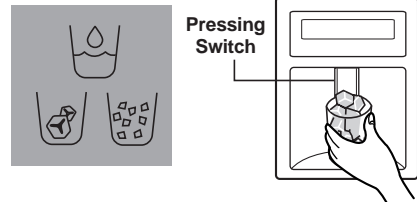

7. Dispenser Light

Whenever the light button is pressed, the display changes as shown below.

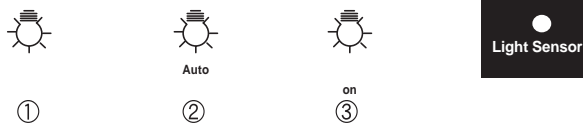

- (1) Normal status: When dispenser is operated, DISPENSER LIGHT is ON.
- (2) AUTO status: Detecting the lighting of room by LIGHT SENSOR, DISPENSER LIGHT is on and off automatically.
- (3) ON status: DISPENSER LIGHT is on continuously.

8. Control Of Freezer Fan Motor

- (1) Freezer fan motor has high and standard speeds.
- (2) High speed is used at power-up, for Ice Plus, and when refrigerator is overloaded. Standard speeds is used for general purposes.
- (3) To improve cooling speed, the RPM of the freezer fan motor changes from normal speed to high.
- (4) High speed (2700RPM) : Initial power on or load corresponding operation, Ice Plus
Normal speed (2400RPM) : General working conditions.
- (5) Fan motor stops when a refrigerator or freezer door opens.

9. Cooling Fan Motor

- (1) The cooling fan is switched ON and OFF in conjunction with the compressor.
- (2) The cooling fan runs at a single speed.
- (3) The Failure sensing method is the same as in the fan motor of the freezing fan motor(refer to failure diagnosis function table for failure display).

10. Icing Fan

- (1) The Icing Fan is controlled by the the sensor on the top of the ice room.
- (2) The Failure sensing method is the same as in the fan motor of the freezer (refer to failure diagnosis function table for failure display)

11. Ice Plus

- (1) The purpose of this function is to intensify the cooling speed of freezer and to increase the amount of ice.
- (2) Whenever selection switch is pressed, selection/release, the LED will turn ON or OFF.
- (3) If there is a power outage and the refrigerator is powered on again, Ice Plus will be canceled.
- (4) To activate this function, press the Ice Plus key and the LED will turn ON. This function will remain activated for 24 hours. The first three hours the compressor and Freezer Fan will be ON. The next 21 hours the freezer will be controlled at the lowest temperature. After 24 hours or if the Ice Plus key is pressed again, the freezer will return to its previous temperature.
- (5) During the first 3 hours:
 - Compressor and freezer fan (HIGH RPM) run continuously.
 - If a defrost cycle begins during the first 90 minutes of Ice Plus, the Ice Plus cycle will complete its cycle after defrosting has ended.
If the defrost cycle begins when Ice Plus has run for more than 90 minutes, Ice Plus will run for two hours after the defrost is completed.
 - If Ice Plus is pressed during defrost, Ice Plus LED is on but this function will start seven minutes after defrost is completed and it shall operate for three hours.
 - If Ice Plus is selected within seven minutes after compressor has stopped, the compressor (compressor delays seven minutes) shall start after the balance of the delay time.
 - The fan motor in the freezer compartment runs at high speed during Ice Plus.
- (6) For the rest of the 21 hours, the freezer will be controlled at the lowest temperature.

12. Freezer and Refrigerator Lamp Auto Off

- (1) To avoid heat damage caused by the lamp, it is turned off automatically when the refrigerator door is open for more than 7 minutes.

13. Alarm for Open Door

- (1) This feature sounds a buzzer when the freezer or refrigerator door is not closed within 1 minute after it is opened.
- (2) One minute after the door is opened, the buzzer sounds three times each for one half seconds. These tones repeat every 30 seconds.
- (3) The alarm is cancelled when the freezer or the refrigerator is closed.

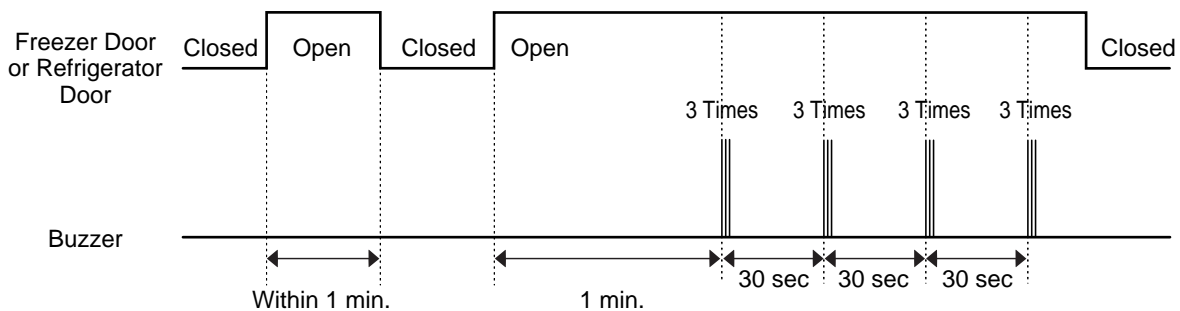

14. Defrosting (removing frost)

- (1) Defrosting starts each time the COMPRESSOR running time reaches 7 hours.
- (2) For initial power on or for restoring power, defrosting starts when the compressor running time reaches 4 hours.
- (3) Defrosting stops if the sensor temperature reaches 46.4°F (8°C) or more. If the sensor doesn't reach 46.4°F (8°C) in 2 hours, the defrost mode is malfunctioning. (Refer to the defect diagnosis function, 15.)
- (4) Defrosting won't function if its sensor is defective (wires are cut or short circuited)

15. Defect Diagnosis Function

- (1) Automatic diagnosis makes servicing the refrigerator easy.
- (2) When a defect occurs, the buttons will not operate; but the tones will sound.
- (3) When the defect CODE removes the sign, it returns to normal operation (RESET).
- (4) The defect CODE shows on the Refrigerator and Freezer Display.

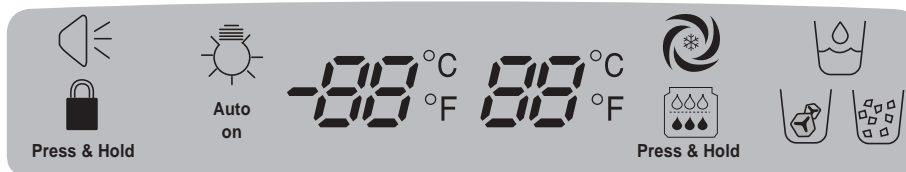

- * LED check function: Press Ice Plus and Freezer buttons for a second, display LED graphics on.
If releasing the button, the LED graphic displays the previous status.

3-2. Ice Maker Function

1. Operation Principle of icemaker

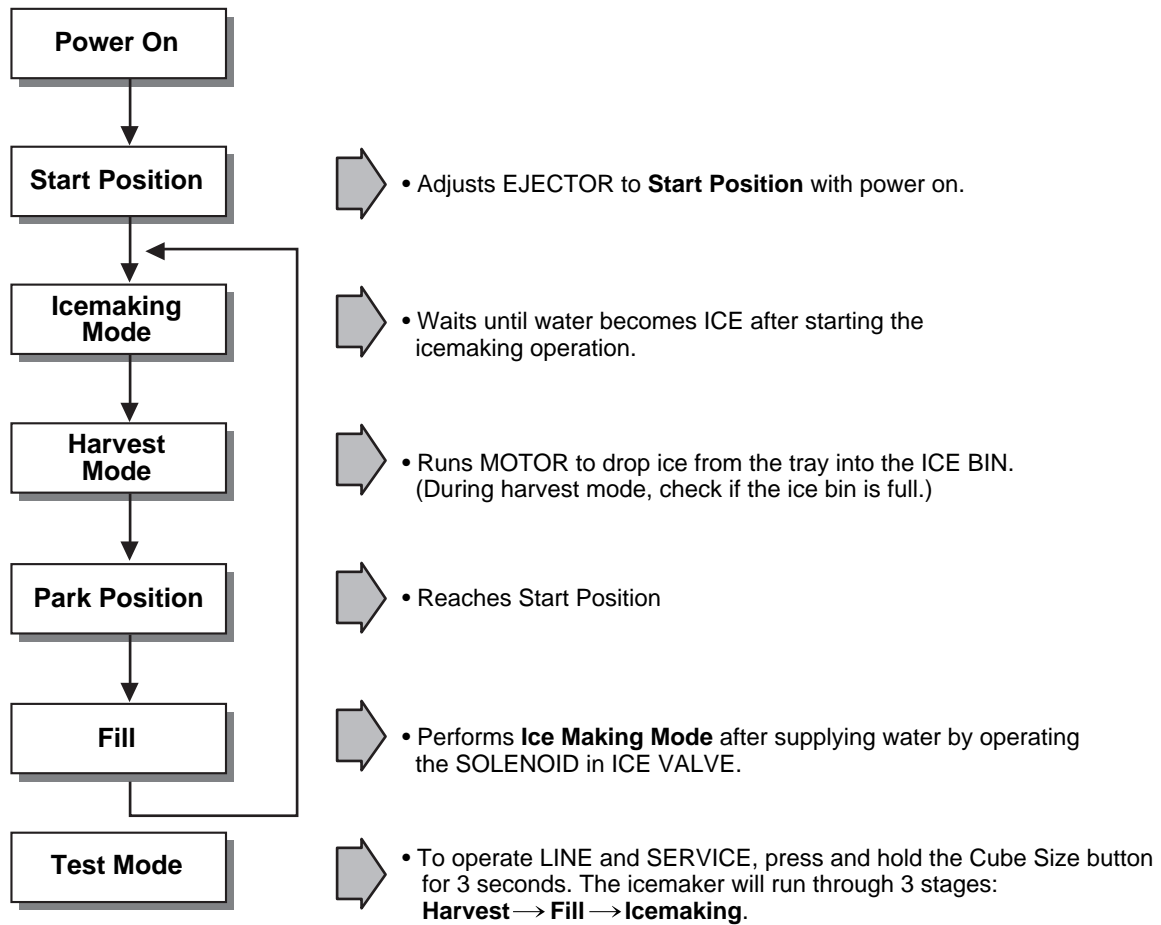

(1) Turning the Icemaker stop switch off (O) stops the ice making function.

(2) Setting the Icemaker switch to OFF and then turning it back on will reset the icemaker control.

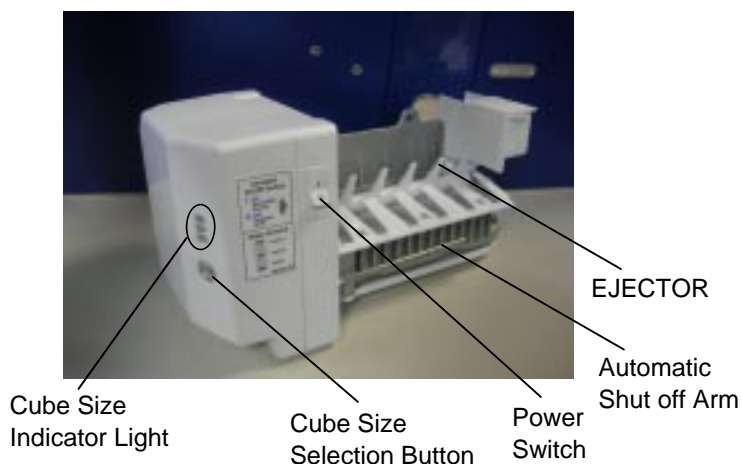

2. Icemaking Mode

- (1) Icemaking refers to the freezing of supplied water in the ice tray. Complete freezing is assured by measuring the temperature of the tray with Icemaking SENSOR.
 - (2) Icemaking starts after completion of the water fill operation.
 - (3) The icemaking function is completed when the sensor reaches $19\text{ }^{\circ}\Delta\text{F}$ ($-7\text{ }^{\circ}\Delta\text{C}$), 55 minutes after starting.
- NOTE : After the icemaker power is ON, the icemaker heater will be on for test for 6 seconds.



3. Harvest Mode

- (1) Harvest (Ice removing) refers to the operation of dropping cubes into the ice bin from the tray when icemaking has completed.
 - (2) Harvest mode:
 - The Heater is ON for 30 seconds, then the motor starts.
 - The feeler arm senses the quantity of ice in the ice storage bin while rotating with the EJECTOR.
 - A. Ice storage bin is full : The EJECTOR stops (heater off).
 - B. Ice storage bin is not full : The EJECTOR rotates twice to open for ice.
- * If the EJECTOR does not rotate once within 5 minutes in B mode, separate heater control mode starts operating to prevent the EJECTOR from being constrained. (It is recommended that the user open for ice to return to normal mode.)

4. Fill/Park Position

- (1) Once a normal harvest mode has been completed, the water solenoid will be activated.
- (2) The amount of water is adjusted by pressing the fill key repeatedly. This changes the time allowed for fill as illustrated in the table below.





Water supply amount TABLE

STAGE	TIME TO SUPPLY	INDICATIONS	REMARKS
1	5 sec.		The water amount will vary depending on the water control switch setting as well as the water pressure of the connected water line.
2	5.5 sec. (FIRST STAGE)		
3	6 sec.		

5. Function TEST

- (1) This is a forced operation for test, service, cleaning, etc. It is operated by pressing and holding the cube size button for 3 seconds.
- (2) The test works only in the Icemaking Mode. It cannot be entered from the Harvest or Fill mode.
- (3) **Caution!** Caution! Caution! Caution! If the test is performed before water in the icemaker is frozen, the ejector will pass through the water. When the fill mode begins (Stage 4), unless the water supply has been shut off, added water will overflow into the ice bin. If the control doesn't
- (4) After water is supplied, the normal CYCLE is followed: **icemaking** → **Harvest** → **Park Position** → **Fill**.
- (5) Five seconds after Stage 5 is completed, the icemaker returns to MICOM control. The time needed to supply water resets to the

Diagnosis TABLE

STAGE	ITEMS	INDICATOR	REMARKS
1	HEATER		Five seconds after the heater starts, it will go off if the temperature by sensor is higher than 10°C
2	MOTOR		Five seconds after the heater starts, you can confirm that the motor is moving.
3	HALL IC I		Check whether ice bin is full. If the ice bin is full, the motor and heater are off, but on standby until the ice bin is empty.
4	HALL IC II		You can confirm HALL IC detection of start position.
5	VALVE		Two seconds after the detection of start position, you can confirm that the valve is on.
6	Reset	Return to Status prior to TEST MODE	Five seconds after the fifth stage is completed, the icemaker resets to initial status.

6. Error codes shown on the icemaker water supply control panel

NO	DIVISION	INDICATOR	CONTENTS	REMARKS
1	Normal	Mark time to supply	None	Display switch operates properly
2	Icemaking sensor malfunction		Open or short-circuited wire	Make sure that the wire on each sensor is connected.

5. ADJUSTMENT

5-1. Compressor

1. Role

The compressor intakes low temperature and low pressure gas from the evaporator of the refrigerator and compresses this gas to high-temperature and high-pressure gas. It then delivers the gas to the condenser.

2. Composition

The compressor includes overload protection. The PTC starter and OLP (overload protector) are attached to the outside of the compressor. Since the compressor is manufactured to tolerances of 1 micron and is hermetically sealed in a dust and moisture-free environment, use extreme caution when performing repairs.

3. Note for usage

- (1) Be careful not to allow over-voltage and over-current.
- (2) If compressor is dropped or handled carelessly, poor operation and noise may result.
- (3) Use proper electric components appropriate to the particular compressor in your product.
- (4) Keep the compressor dry. If the Compressor gets wet (in the rain or a damp environment) and rust forms in the pin of the Hermetic Terminal, poor operation and contact may result.
- (5) When replacing the compressor, be careful that dust, humidity, and soldering flux don't contaminate the inside of the compressor. Dust, humidity, and solder flux may contaminate the cylinder and may cause noise, improper operation, or even lock up.

4. diagnosis

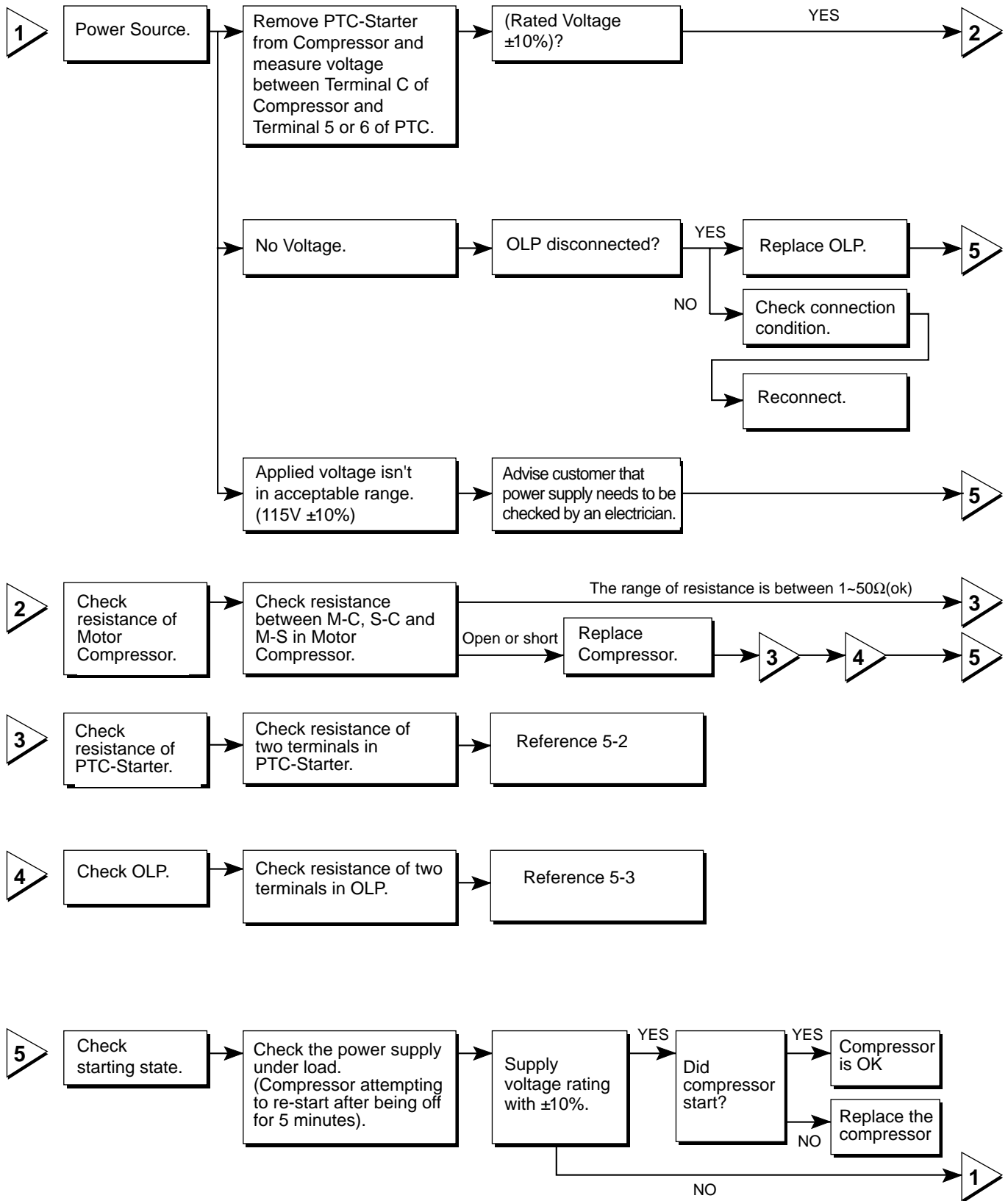

5-2. Positive Temperature Coefficient (PTC) – Starter

1. Composition

- (1) PTC (Positive Temperature Coefficient) is a no-contact semiconductor starting device which uses ceramic material consisting of BaTiO₃.
- (2) The higher the temperature is, the higher the resistance value. These features are used as a starting device for the motor.

2. Role

- (1) The PTC is attached to the sealed compressor and is used for starting the compressor motor.
- (2) The compressor is a single-phase induction motor. For starting operation, the PTC allows current flow to both the start winding and main winding.

3. PTC – Applied circuit diagram

● Starting Method for the Motor

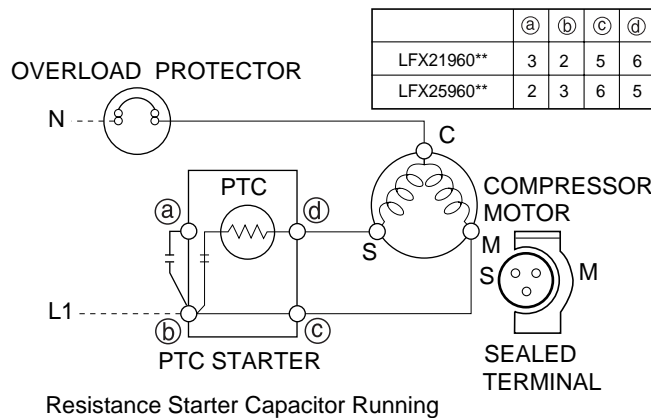

4. Motor restarting and PTC cooling

- (1) It requires approximately 5 minutes for the pressure to equalize before the compressor can restart.
- (2) The PTC device generates heat during operation. Therefore, it must be allowed to cool before the compressor can restart.

5. Relation of PTC – Starter and OLP

- (1) If the compressor attempts to restart before the PTC device is cooled, the PTC device will allow current to flow only to the main winding.
- (2) The OLP will open because of the over current condition. This same process will continue (3 to 5 times) when the compressor attempts to restart until the PTC device has cooled. The correct OLP must be properly attached to prevent damage to the compressor. Parts may appear physically identical but could have different electrical ratings. Replace parts by part number and model number. Use only approved substitute parts.

6. Note for Using the PTC-Starter

- (1) Be careful not to allow over-voltage and over-current.
- (2) Do not drop or handle carelessly.
- (3) Keep away from any liquid. If liquid such as oil or water enters the PTC, the materials may fail due to breakdown of their insulating capabilities.
- (4) If the exterior of the PTC is damaged, the resistance value may be altered. This can cause damage to the compressor and result in a no-start or hard-to-start condition.
- (5) Always use the PTC designed for the compressor and make sure it is properly attached to the compressor. Parts may appear physically identical but could have different electrical ratings. Replace parts by part number and model number. Use only approved substitute parts.

5-3. Over Load Protector (OLP)

1. Define

- (1) The OLP (OVERLOAD PROTECTOR) is attached to the Compressor and protects the motor by opening the circuit to the motor if the temperature rises and activating the bimetal spring in the OLP.
- (2) When high current flows to the compressor motor, the Bimetal works by heating the heater inside the OLP, and the OLP protects the Motor by cutting off the current flowing to the Compressor Motor.

2. Role

- (1) The OLP is attached to the sealed compressor used for the refrigerator. It prevents the motor coil from being started in the compressor.
- (2) For normal operation of the OLP, do not turn the adjustment screw of the OLP in any way.

(OVERLOAD PROTECTOR cross section)

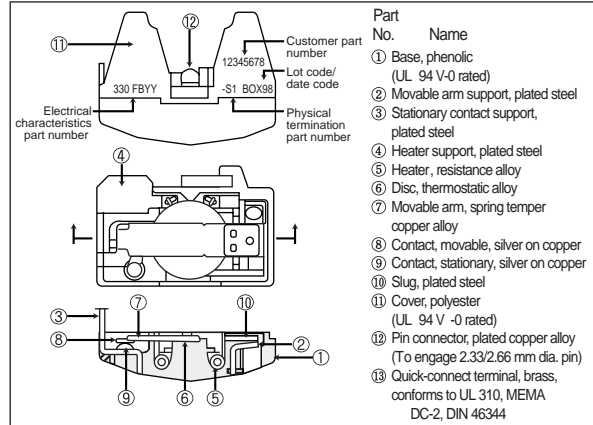

5-4. Remove the cover Positive Temperature Coefficient (PTC)

- (1) Remove the cover of the mechanical area.
- (2) Disconnect the two clamps holding the compressor in place.
- (3) Loosen two screws on compressor base.

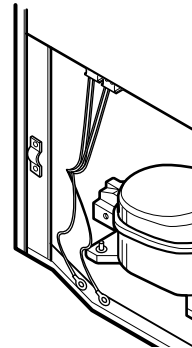

- (4) Use a screwdriver to pry off the cover.
- (5) Assembly is the reverse order of disassembly.

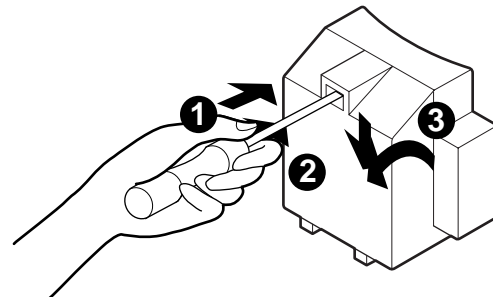

6. TROUBLESHOOTING

6-1. Error Code Summary

▲WARNING : When you check the Resistance values, be sure to turn off the power.
And wait for the voltage-discharge sufficiently.

NO	Error Detection Category	Error Display		Error Generation Factors	Remark
		Freezer Temperature	Ref. Temperature		
1	Normality			None	Normal operation of Display
2	Freezer Sensor Error	Er	FS	Short or Disconnection of Freezer Sensor	Check each sensor and its connector.
3	Refrigerator Sensor Error	Er	rS	Short or Disconnection of Refrigerator Sensor	
4	Defrosting Sensor Error	Er	dS	Short or Disconnection of Defrosting Sensor	
5	Icing Sensor Error	Er	IS	Short or Disconnection of Icing Sensor	
6	Poor Defrosting	Er	dH	Even though it is passed 1 hour since then Defrosting , if Defrosting sensor is not over 8°C, it is caused	Temperature Fuse Disconnection, Heater disconnection, DRAIN Jam, Poor Relay for Heater
7	Abnormality of BLDC FAN Motor for Ice Making	Er	IF	It is caused when feedback signal isn' t over 115 seconds during BLDC FAN motor operating	Poor BLDC Motor connection, DRIVE IC, and TR Tx/Rx between icemaker and main board.
8	Abnormality of BLDC FAN Motor for Freezer	Er	FF	It is caused when feedback signal isn' t over 115 seconds during BLDC FAN motor operating	Poor BLDC Motor connection, DRIVE IC, and TR Tx/Rx between icemaker and main board.
9	Abnormality of BLDC FAN Motor for Mechanic Room	Er	CF	It is caused when feedback signal isn ' t over 115 seconds during BLDC FAN motor operating	Poor BLDC Motor connection, DRIVE IC, and TR Tx/Rx between icemaker and main board.
10	Communication Error	Er	CO	Communication Error between Micom of Main PCB and Display Micom	Poor Communication connection,Poor TR of Transmitter and Receiver Tx/Rx between icemaker and main board.

6-2. Troubleshooting With Error

Freezer Sensor Error

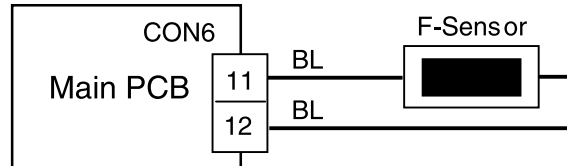

Wiring diagram

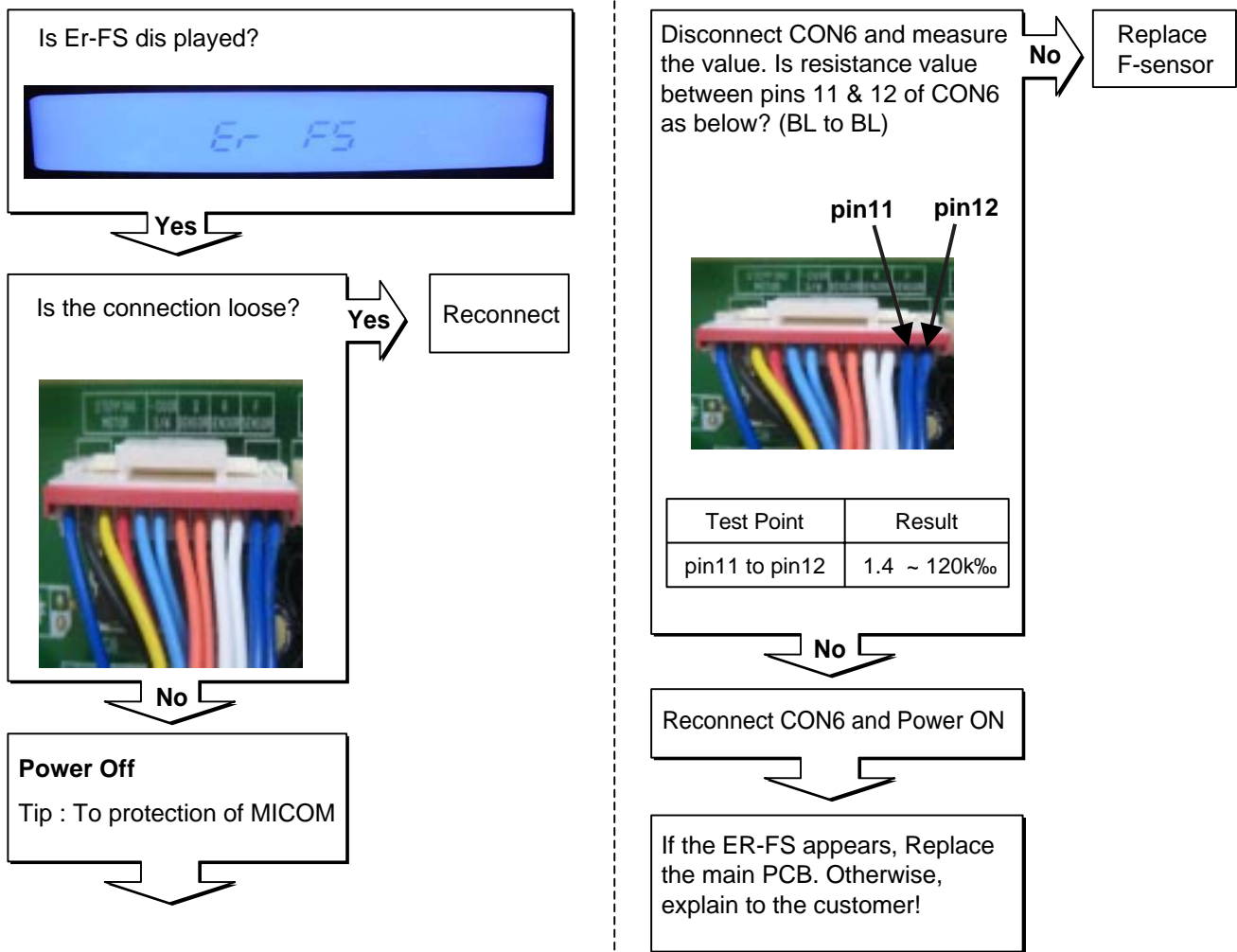

Refrigerator Sensor Error

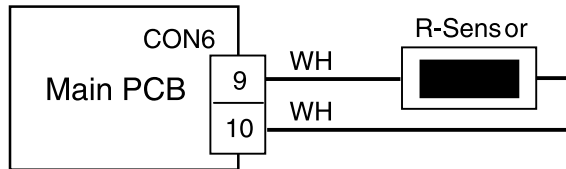

Wiring dia gram

Is Er-rS displayed?



Yes

Is the connection loose?



No

Power Off

Tip : To protection of MICOM

Yes

Reconnect

Disconnect CON6 and measure the value. Is resistance value between pins 9 & 10 of CON6 as below? (WH to WH)

No

Replace R-sensor

pin9 pin10

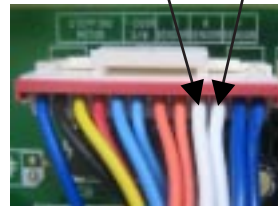

Tpin10 pin9	Result
pin9 to pin10	6 ~ 300 k% _o

No

Reconnect CON6 and Power ON

If the ER-rS appears, Replace the main PCB. Otherwise, explain to the customer!

Defrost Sensor Error

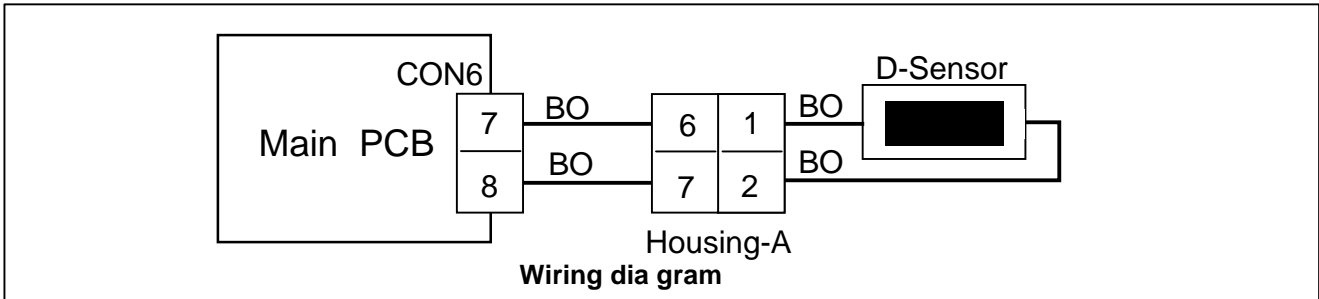

Is Er-dS displayed?

Yes

Is the connection loose?

Yes → Reconnect

No →

Power Off
Tip : To protection of MICOM

Disconnect CON6 and measure the value. Is resistance value between pins 7 & 8 of CON6 as below? (BO to BO)

pin7 pin8

Test Point	Result
Pin7 to pin8	6 ~ 300k%

No → Replace D-sensor

No →

Is resistance value between pins 1 & 2 of Housing- A as below? (BO to BO)

No → Replace a D-Sensor

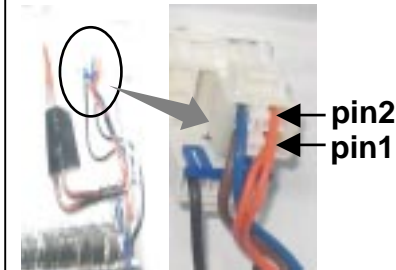

Checking Open or Short of wire

Test Point	Result
Pin1 To pin2	1.156 ~141.5k%

Yes

Reconnect and Power ON

If the ER-dS appears, Replace the main PCB. Otherwise, explain to the customer!

Icing Room Sensor Error

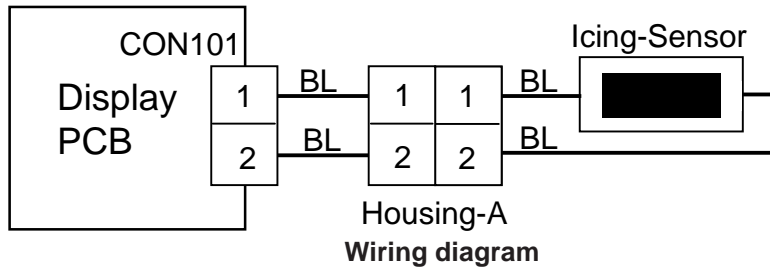

Is Er-IS displayed?



Yes

Is the connection loose?

Yes

Reconnect

Display PCB



Inner of Icing door



No

Disconnect CON101 and measure the value. Is resistance value between pins 1 & 2 of CON101 as below? (BL to BL)

No

Replace Main PCB

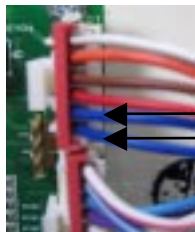

pin2 BL
pin1 BL

Icing room Sensor Resistance

Test Point	Result
pin1 to pin2	1.156 ~141.5k%

Yes

Is resistance value between pins 1 & 2 of Housing- A as below? (BL to BL)

No

Replace the Icing-Sensor

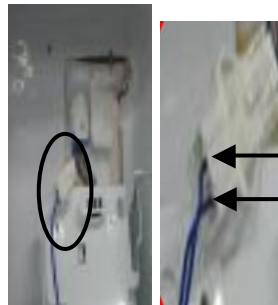

pin1 BL
pin2 BL

Checking Open or Short of wire

Test Point	Result
(1) To (2)	1.4 ~120k%

Yes

Reconnect and Power ON

If the ER-IS appears, Replace Main PCB
Otherwise, explain to the customer!

Defrost Heater Error

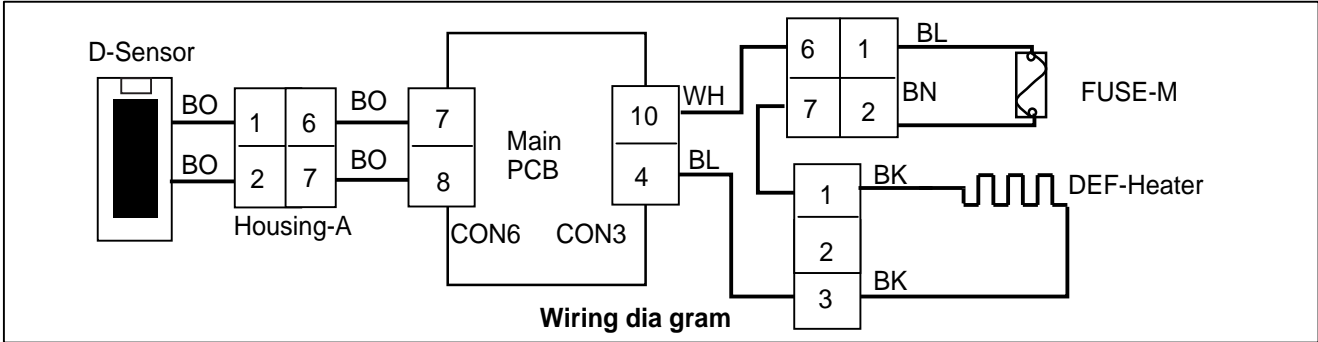

Is Er-dH displayed?

Yes

Is the connection loose?

Yes

Reconnect

CON6

CON3

No

Enter the TEST 3 MODE

Is the voltage value between pins 10 (WH) and 4 (BL) of CON3 115 V AC?

Yes

Replace MAIN PCB

pin10 WH

pin4 BL

Relay operation

Test Point	Result
pin4 To pin 10	115V

Yes

Reset TEST3 MODE(Normal)

Is the voltage value between pins 10 (WH) and 4 (BL) of CON3 for 0 V AC?

No

Replace MAIN PWB

pin10 WH

pin4 BL

Relay Open

Test Point	Result
Reset/Norm op	0 ~ 2 V

Yes

Is the resistance value between pins 10(WH) And 4(BL) of CON3 like as below?

Yes → Normal



pin10 WH
pin4 BL

Resistance

Test Point	Result
(1) To (2)	34 ~ 42 Ω

No →

Is the connection loose?

Yes → Reconnect



No →

Is the resistance value of Fuse -M like as below?

No → Replace Fuse-M

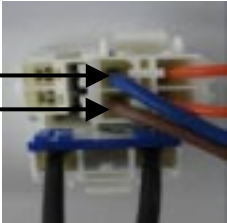

(1) BL
(2) BN

Open or Short of Fuse-M

Test Point	Result
(1) To (2)	0 Ω

Yes →

Is the resistance value of heater like as below?

No → Replace Heater



(1) (2)

Heater Resistance

Test Point	Result
(1) To (2)	34 ~ 42 Ω

Yes →

Is the resistance value of DEF-sensor like as below? It depends on the temperature.

No → Replace DEF-sensor



(1) BO
(2) BO

Defrost Sensor Resistance

Test Point	Result	Test Point	Result
-30°C	129.3 kΩ	10°C	19.53 kΩ
-20°C	76.96 kΩ	20°C	13.03 kΩ
-10°C	47.34 kΩ	30°C	8.896 kΩ
0°C	30 kΩ	40°C	6.201 kΩ

Yes →

Explain to the customer! :
It can be occurred, when the gasket is not stuck to product or when you put the high temperature loads (hot foods) a lot in the product.

Freezer Fan Error

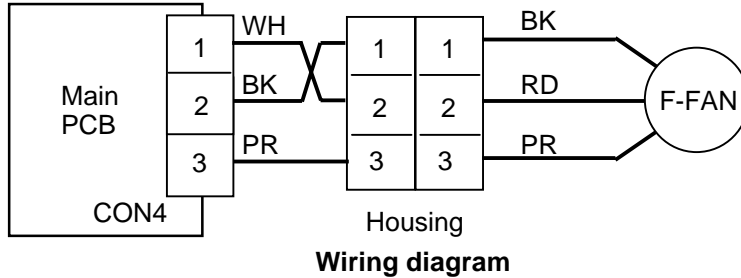

Is Er-FF displayed?



Yes

Is the connection loose?



No

Yes

Reconnect

No

Replace Main PCB

Reset and

Enter the TEST 1 MODE

Is the output voltage between pin1 and pin2 of CON4 like as below?

Pin1 WH Pin2 BK



Freezer Fan Voltages

Test Point	Result
pin1 to pin2	12 ~ 16 V

Yes

Does the cold-air come out of the top of the main duct?



Yes

No

Check fan motor (Connector, Frozen, Locked)



Is the feedback voltage between pin2 and pin3 of CON4 like as below? (from motor to main board)

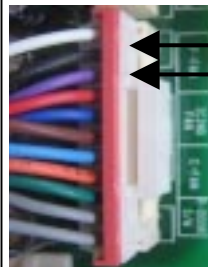

Pin2 BK
Pin3 PR

Feedback Voltages

Test Point	Result
pin2 to pin3	1 ~ 4 V

Yes

No

Replace Main PCB

Explain to the customer!

Condenser Fan Error

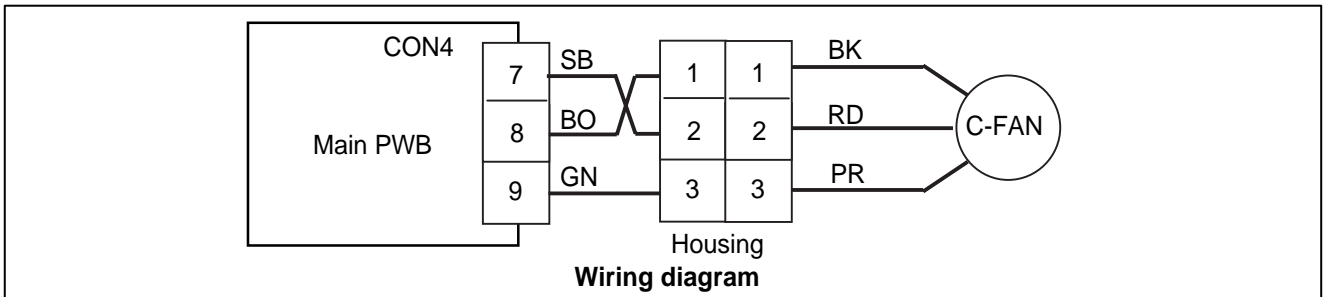

Is Er-CF displayed?

Yes

Is the connection loose?

Yes → Reconnect

No →

Reset and Enter the TEST 1 MODE
Is the output voltage between pin7 and pin8 of CON4 like as below?

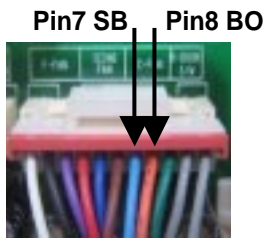

Condenser Fan Voltages

Test Point	Result
pin7 to pin8	12 ~ 16 V

Yes

No → Replace Main PCB

Is the condenser fan rotate?

No → Check fan motor (Connector, Locked, mouse)

Yes →

Is the feedback voltage between pin8 and pin9 of CON4 like as below? (from motor to main board)

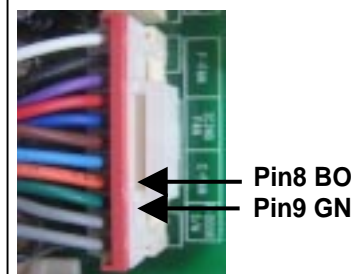

Feedback Voltages

Test Point	Result
pin8 to pin9	1 ~ 4 V

Yes

Explain to the customer!

Icing Room Fan Error

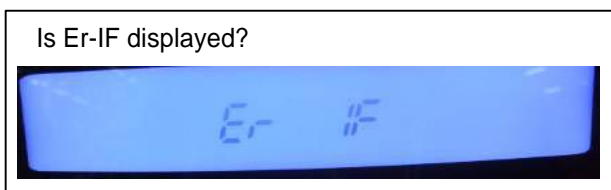
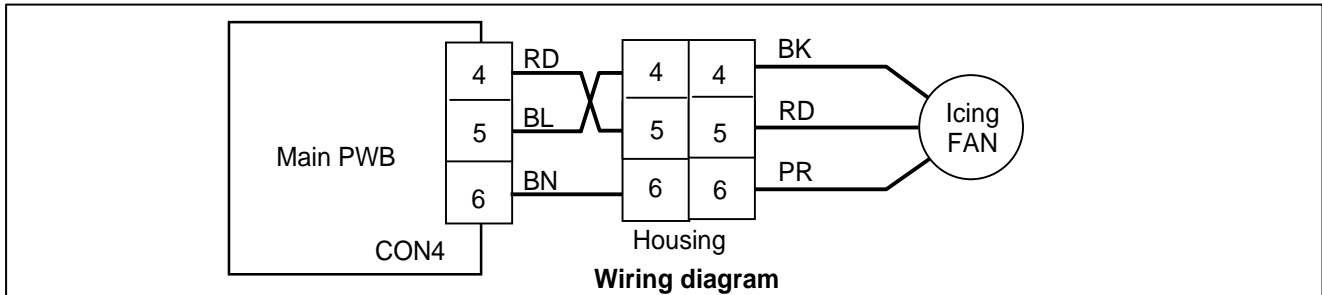

Yes

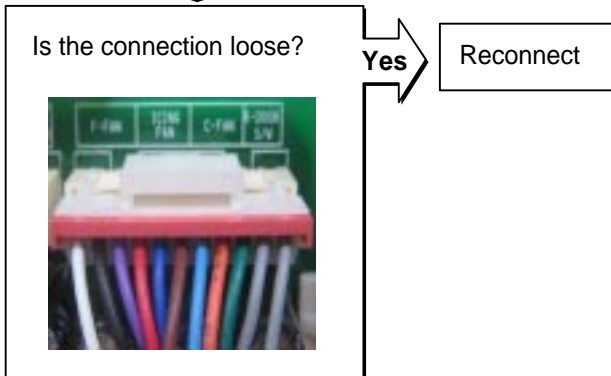

NO

Reset and Enter the TEST 1 MODE

Is the output voltage between pin4 and pin5 of CON4 like as below?

Pin4 RD Pin4 BL

Icing Fan Voltages

Test Point	Result
pin4 to pin5	12 ~ 16 V

Yes

NO → Replace Main PCB

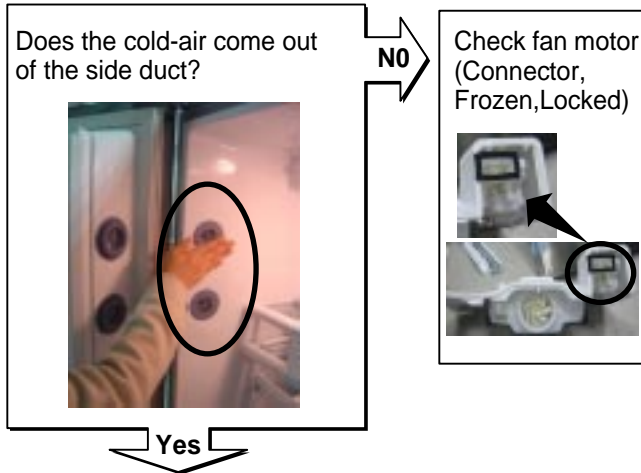

Yes

Is the feedback voltage between pin5 and pin6 of CON4 like as below?
(from motor to main board)

NO → Replace Main PCB

Feedback Voltages

Test Point	Result
pin5 to pin6	1 ~ 4 V

Yes

Explain to the customer!

Communication Error

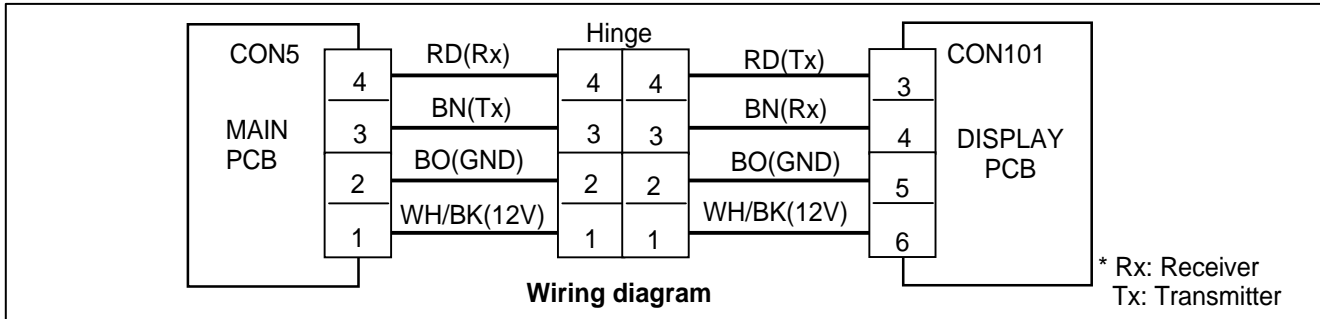

Is Er-CO displayed?

Yes

Display PCB
Is the connection loose?

Yes → Reconnect

No

Display PCB
Is the voltage between pins 4 and pin 5 of CON101?

No → Replace the Display PCB

Receiver fail Voltages

Test Point	Result
pin4 to pin5	0 V or 5 V

Yes

Display PCB
Is the voltage between pin3 and pin5 of CON101 0 V or 5 V?

No → Replace Display PCB

Transmitter Voltages

Test Point	Result
pin3 to pin5	0 V or 5 V

Yes

Is the joint connection loose In the Hinge?

No → Reconnect

Yes



Main PCB
Is the connection loose?



Yes

Reconnect

No

Main PCB
Is the voltage between pins 2 and pin 3 of CON5 0V or 5V?

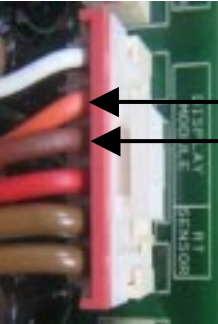

No

Replace the Main PCB

Receiver Voltages

Test Point	Result
pin2 to pin3	0 V or 5 V

Yes

Main PCB
Is the voltage between pin2 and pin4 of CON5 0 V or 5 V?

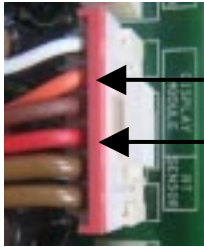

No

Replace Main PCB

Transmitter Voltages

Test Point	Result
(1) to (2)	0 V or 5 V

Yes

After plug in,
If Er-CO is disappeared,
Explain to the customer!



6-3. Troubleshooting Else

CUBE Mode doesn't work

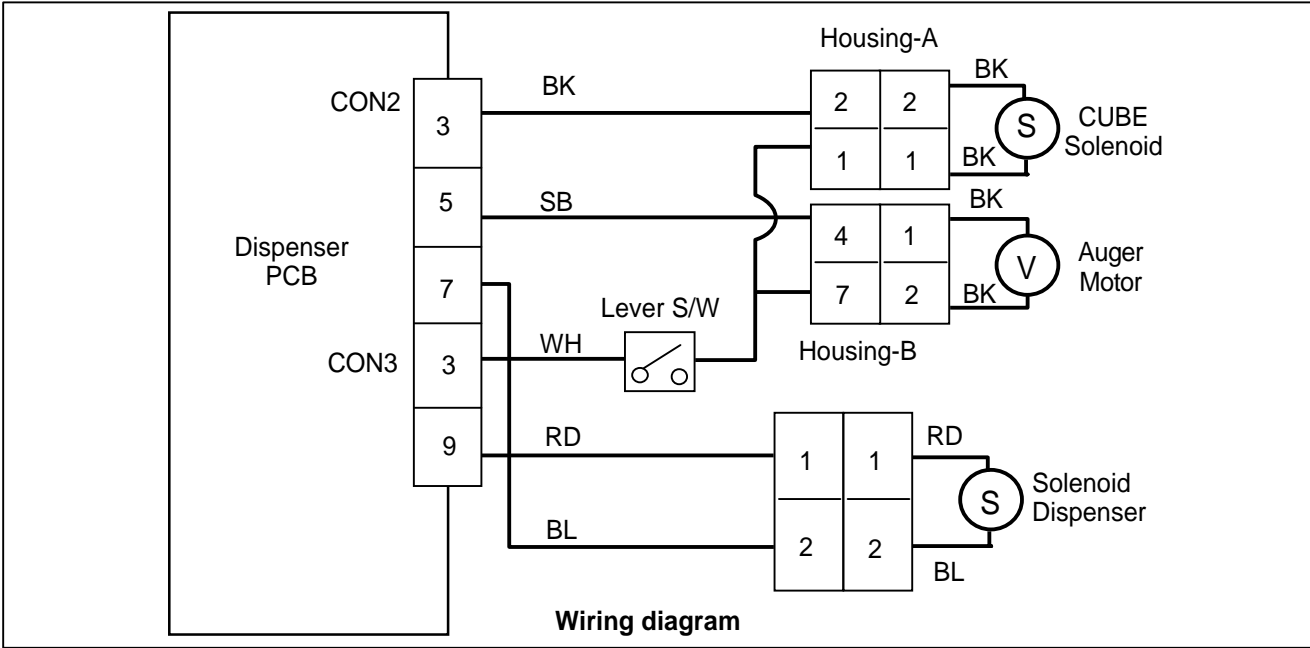

Wiring diagram

Dispenser PCB
Is the connection loose?

Yes → Reconnect

No

In CUBE Mode,
Is the voltage between pin3 of CON2 and pin3 of CON3 like as below, while pushing the lever switch?

No → Replace Dispenser PCB

CON2 Pin3 BK

CON3 Pin3 WH

Relay open of cube solenoid

Level switch	Test Point	Result
Pushing	pin3 to pin3	115 V
Normal	pin3 to pin3	0 ~ 2 V

Yes



In CUBE Mode,
Is the voltage between pin5 of CON2 and pin3 of CON3 like as below, while pushing the lever switch?

No → Replace Dispenser PCB

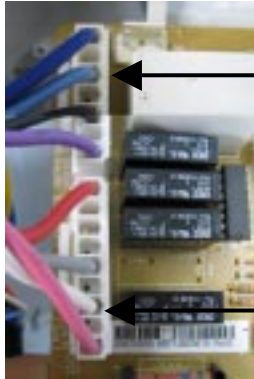

CON2
Pin5 SB

CON3
Pin3 WH

Output voltage of auger motor

Level switch	Test Point	Result
Pushing	pin5 to pin3	115 V
Normal	pin5 to pin3	0 ~ 2 V

Yes

In CUBE Mode,
Is the voltage between pin7 of CON2 and pin9 of CON3 like as below, while pushing the lever switch?

No → Replace Dispenser PCB

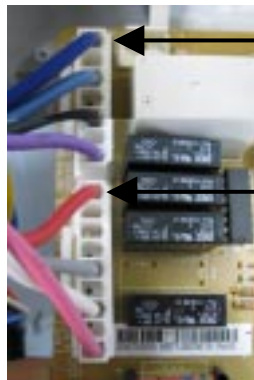

CON2
Pin7 BL

CON3
Pin9 RD

Output voltage of dispenser solenoid

Level switch	Test Point	Result
Pushing	pin7 to pin9	115 V
Normal	pin7 to pin9	0 V

Yes

Is the resistance value between (1) and (2) of the Auger motor like as below?

No → Replace Auger Motor

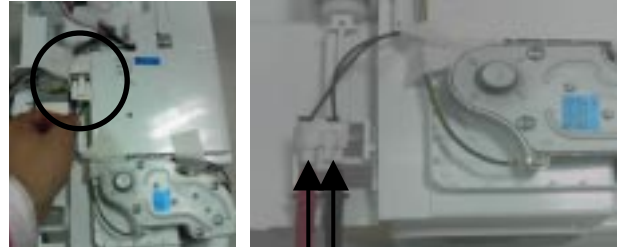

(1)(2)

Resistance of Auger Motor

Test Point	Result
(1) To (2)	2.38 ~ 4.02 Ω

Yes

Is the resistance value between (1) and (2) of the cube solenoid like as below?

No → Replace Cube Solenoid

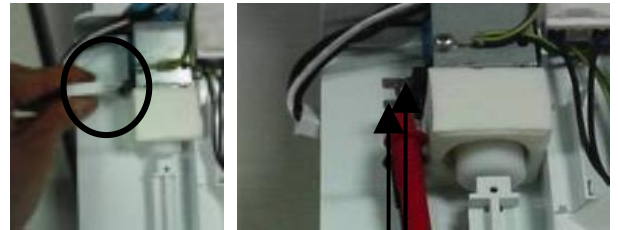

(1)(2)

Resistance of Cube solenoid

Test Point	Result
(1) To (2)	32 ~ 40 Ω

Yes



Is the resistance between (1) and (2) of the Dispenser solenoid like as below?

No

Replace Dispenser Solenoid

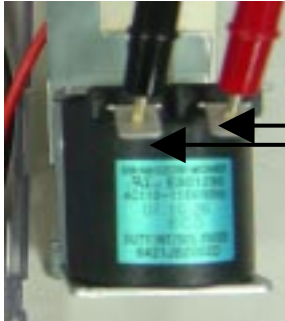

Resistance of Dispenser solenoid

Level switch	Result
(1) to (2)	44 ~54 Ω

Yes

Is the condition of the micro switch like as below?

No

Replace Micro Switch

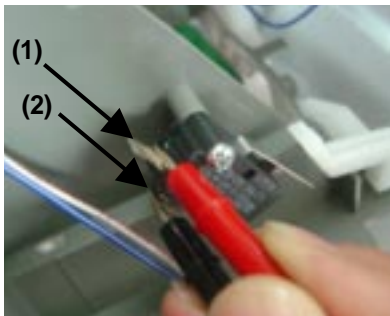

Status	Tester
Normal	Infinity
Push the Lever	0 Ω

Yes

After plug in, explain to the customer!

Crush Mode Doesn't work

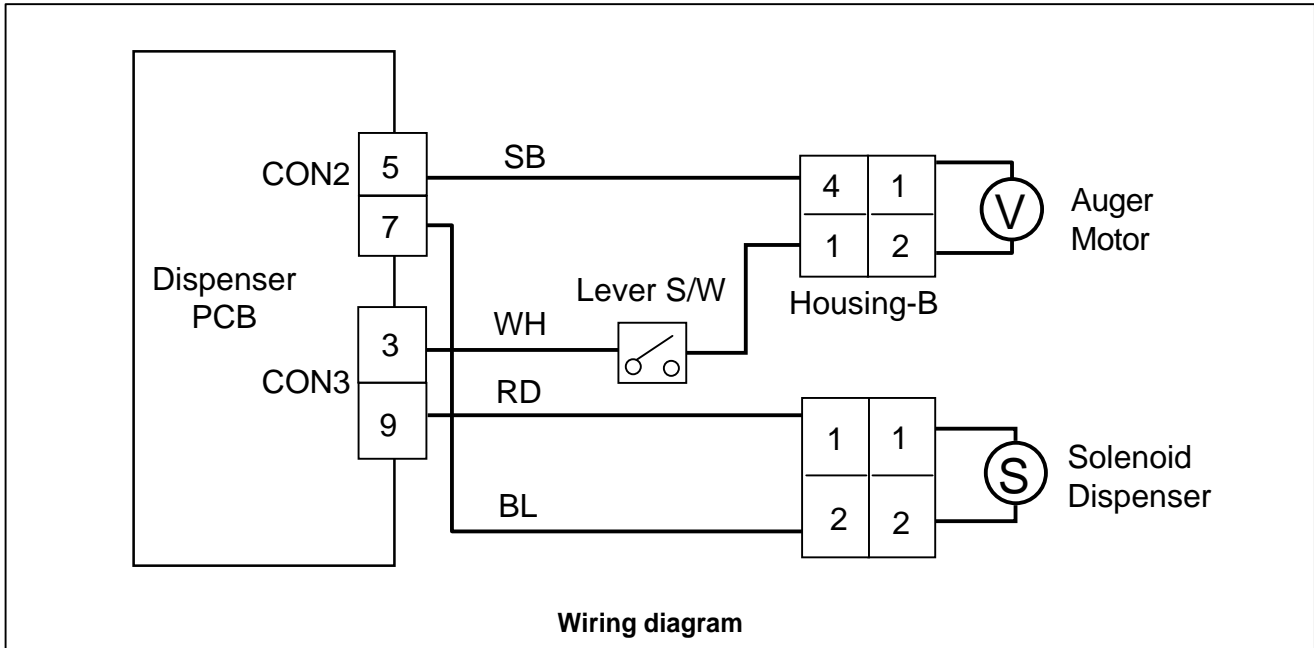

Display PCB
Is the connection loose?

Yes → Reconnect

No

In Crush Mode,
Is the voltage between pin5 of CON2 and pin3 of CON3 like as below, while pushing the lever switch?

No → Replace Dispenser PCB

Output voltage of Auger motor

Level switch	Test Point	Result
Pushing	pin5 to pin3	115 V
Normal	pin5 to pin3	0 V

Yes

In CUBE Mode,
Is the voltage between pin7 of CON2 and pin9 of CON3 like as below, while pushing the lever switch?

No → Replace Dispenser PCB

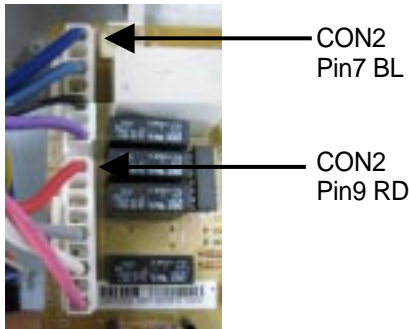

Output voltage of auger motor

Level switch	Test Point	Result
Pushing	pin7 to pin9	115 V
Normal	pin7 to pin9	0 V

Yes →

Is the resistance value between (1) and (2) of the Auger motor like as below?

No → Replace Auger Motor

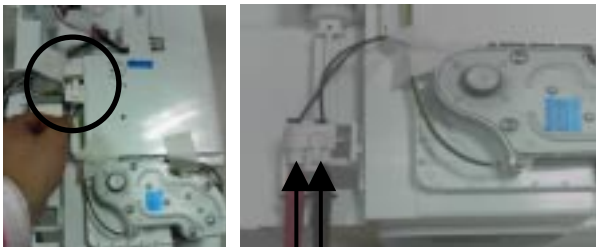

Resistance of Auger Motor

Test Point	Result
(1) To (2)	2.38 ~ 4.02 Ω

Yes →

Is the voltage between (1) and (2) of the Dispenser solenoid like as below?

No → Replace Dispenser Solenoid

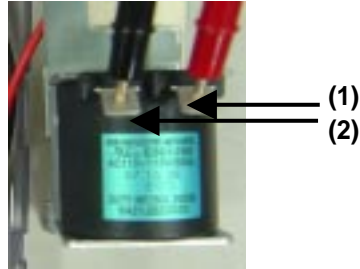

Resistance of Dispenser solenoid

Test Point	Result
(1) To (2)	44 ~ 54 Ω

Yes →

Is the condition of the micro switch like as below?

No → Replace Micro Switch

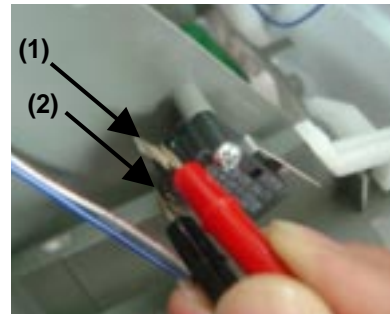

Status	Tester
Normal	Infinity
Push the Lever	0 Ω

Yes →

After plug in, explain to the customer!



Crush Mode Doesn't work

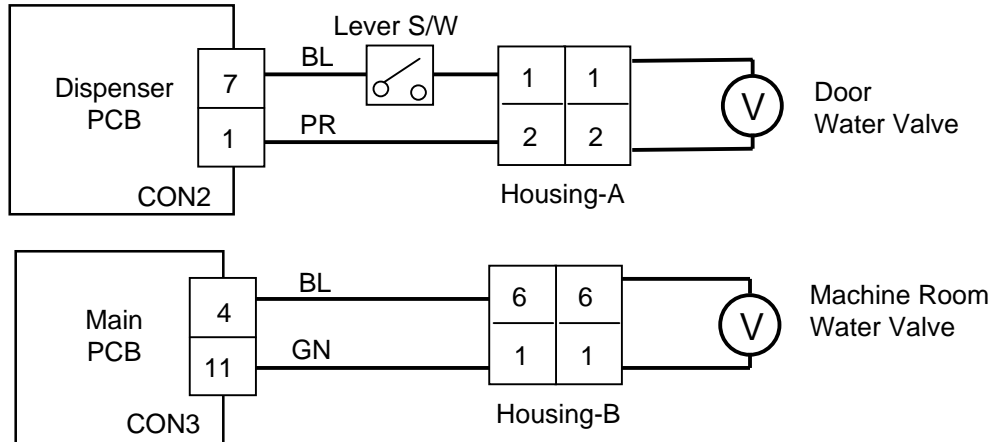

Wiring diagram

Display PCB

Is the connection loose?



Yes

Reconnect

No

In Water Mode,

Is the voltage between pin1 and pin7 of CON2 in dispenser PCB like as below, while pushing the level switch?

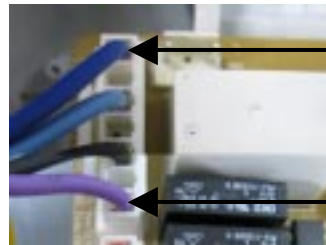

Dispenser PCB
CON2
Pin7 BL

Dispenser PCB
CON2
Pin1 PR

No

Replace
Dispenser
PCB

Output voltage of door water valve

Level switch	Test Point	Result
Pushing	pin1 to pin7	115 V
Normal	pin1 to pin7	0 V

Yes

In Water Mode,
Is the voltage between pin4 and pin11 of CON3 in main PCB like as below, while pushing the level switch?

No

Replace Main PCB

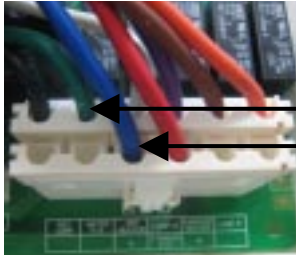

Main PCB
CON3
Pin11 GN
Pin4 BL

Output voltage of machine room water valve

Test Point	Result
pin4 to pin11	115 V

Yes

First Water- valve

Is the resistance value between (1) and (2) of the First-water valve like as below?

No

Replace First Water-valve

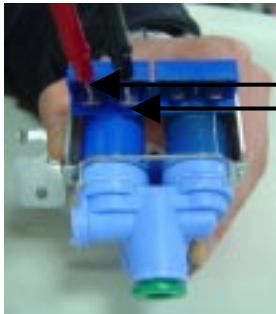

(1)
(2)

Machine room

Checking resistance of First-valve

Test Point	Result
(1) to (2)	360 ~420 Ω

Yes

Second Water- valve

Is the resistance value of Second-water valve like as below?

No

Replace Second Water-valve

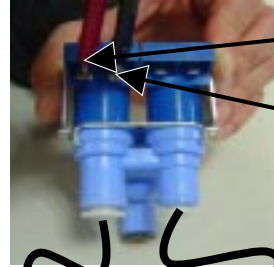

(1)

(2)

In door

Dispenser

Ice Maker

Checking resistance of Second-valve

Test Point	Result
(1) to (2)	360 ~ 420 Ω

Yes

Is the condition of the micro switch like as below?

No

Replace Micro Switch

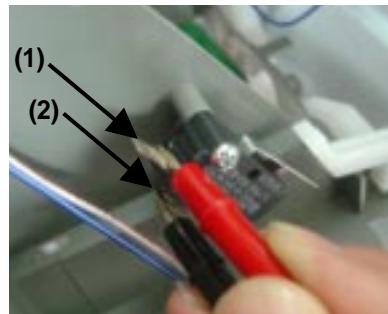

(1)

(2)

Status	Tester
Normal	Infinity
Push the Lever	0 Ω

Yes

After plug in,
explain to the customer!

Freezer-lamp Doesn't work

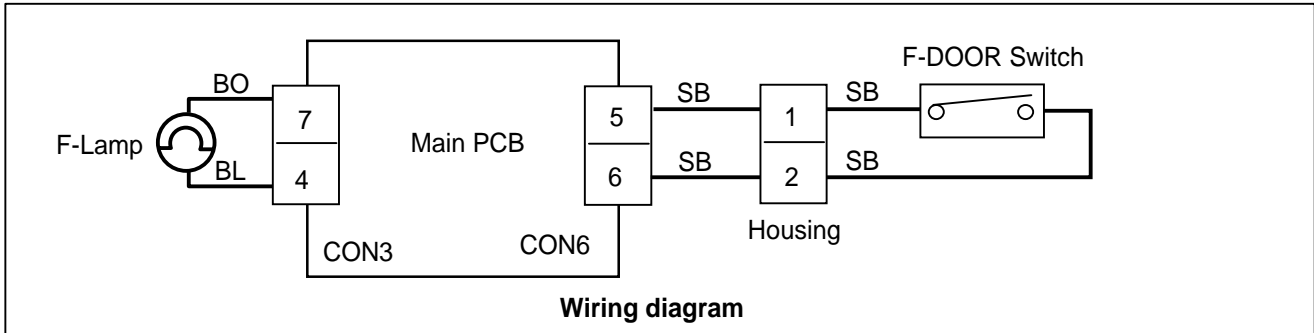

Is the condition of the freezer door switch like as below?

No

Replace Door switch

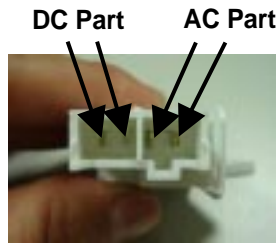

Status	Tester
Normal	0 Ω
Push the Switch	Infinity

Yes

Is the connection loose?

Yes

Reconnect



CON6



CON3

No

Is the voltage between pin 11 and 12 of CON6 like as below?

No

Replace Main PCB



Pin5 SB Pin6 SB

Voltage of Door switch

Door	Test Point	Result
Closed	pin5 to pin6	5 V
Open	pin5 to pin6	0 V

Yes

Is the voltage between pin 4 and pin7 of CON3 like as below?

No

Replace Main PCB

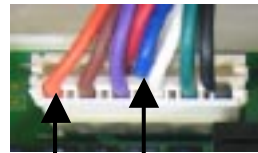

CON3

Pin7 BO Pin4 BL

Voltage of Freezer lamp

Door	Test Point	Result
Closed	pin4 to pin7	0 ~ 2 V
Open	pin4 to pin7	115 V

Yes

Replace Lamp

Refrigerator-lamp Doesn't work

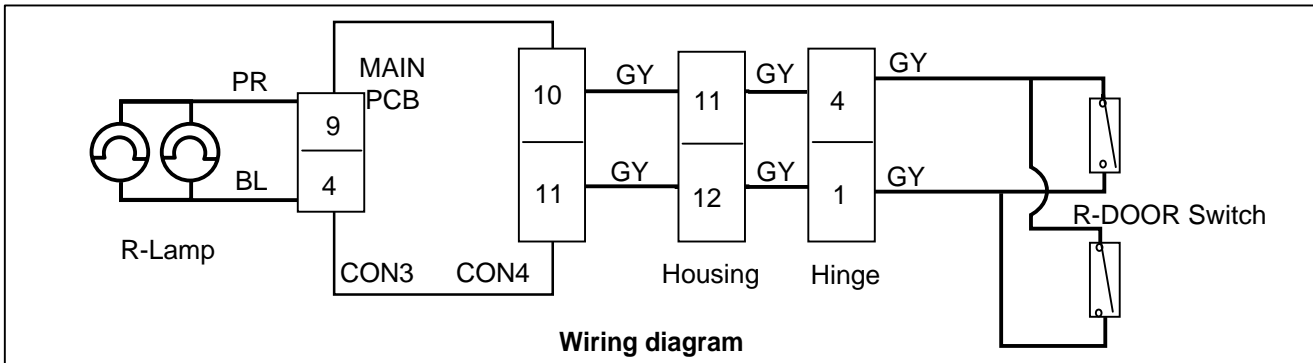

Is the condition of the refrigerator door switch like as below?

No

Replace Door switch

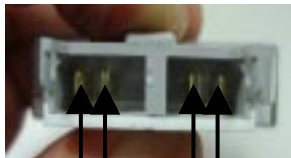

AC Part DC Part

Status	Tester
Normal	0 Ω
Push the Switch	Infinity

Yes

Is the connection loose?

Yes

Reconnect



CON6



CON3

No

Is the voltage between pin10 and pin11 of CON4 like as below?

No

Replace Main PCB

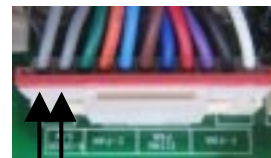

CON4

Pin11 GY Pin10 GY

Voltage of Door switch

Door	Test Point	Result
Closed	pin10 to pin11	5 V
Open	pin10 to pin11	0 V

Yes

Is the voltage between pin4 and pin9 of CON3 like as below?

No

Replace Main PCB



CON3

Pin9 PR Pin4 BL

Voltage of Refrigerator lamp

Door	Test Point	Result
Closed	pin4 to pin9	0 ~ 2 V
Open	pin4 to pin9	115 V

Yes

Replace Lamp

Poor cooling in the refrigerator compartment

MAIN PWB

Is the connection loose?

Yes

Replace

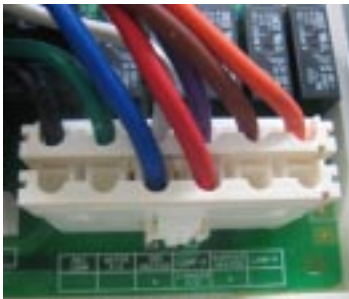

CON3

No

Enter the TEST 1 MODE

Is the voltage between Pins 4 and pin 12 of CON3 like as below?

Yes

Reconnect Main PCB



CON3

Pin12 BK

Pin4 BL

Voltage of Compressor

Test Point	Result
pin4 to pin12	115 V

Yes

Is the voltage between pins 1 and pin 2 of CON4 like as below?

No

Replace the Main PCB

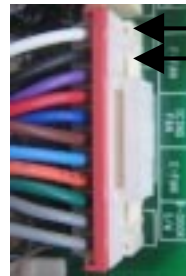

CON4

Voltage of F-fan

Test Point	Result
pin1 to pin2	12 ~ 16 V

Yes

Feedback check.

Is the voltage between Pin 2 and pin3 of CON4 like as below?

No

Replace the Main PCB

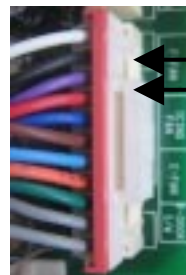

CON4

Feedback voltage of F-fan

Test Point	Result
pin2 to pin3	11 ~ 4 V

Yes

Does the cold-air come out of the top of the main duct?



No → Check the Damper itself

Enter the TEST 2 MODE
Does not cold-air come out of the top of the main duct?



Yes → Check the Damper itself

Checking Damper itself
Is the resistance Values between (1) & (4), (2) & (3) like as below?

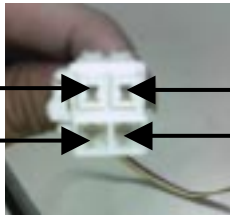

Resistance of Damper

Test Point	Result
(1) to (4)	373 ~456 ‰
(2) to (3)	373 ~456 ‰

No → Replace Damper

Yes →

After reset the unit, take steps to PCB as follows for temperature compensation.

- In the case of 6871JB1431 (by July 2007)
: Compensate with replacing RCR1

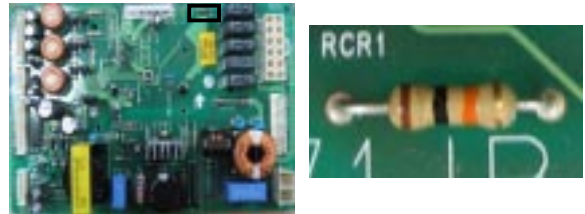



RCR1	Temp. Compension	Result
8.2 k‰	- 0.5 deg	Current
5.6 k‰	- 1 deg	↓ Colder
3.3 k‰	- 1.5 deg	
2 k‰	- 2 deg	
470 k‰	- 2.5 deg	

*** Change RCR1**

- In the case of EBR34917102
(from Aug 2007)
: Compensate with Jump wire cutting



JUMP WIRE	Temp. Compensation
	- 1.0 deg
	- 1.0 deg
Cutting both jumpers affords a 2... temperature compensation	

*** Cutting of jumper wire**

Over cooling in the refrigerator compartment

MAIN PWB

Is the connection loose?



CON3

No

Yes

Reconnect

Enter the TEST 1 MODE

Is the voltage between Pins 4 and pin 12 of CON3 like as below?

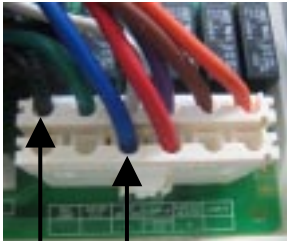

Pin12 BK
Pin4 BL

CON3

Voltage of Compressor

Test Point	Result
pin4 to pin12	115 V

Yes

Yes

Replace Damper

Check the Fan operation by placing your hand in front of the vents to feel for any cold air flow.

Door	Fan-Motor
Open	OFF
Closed	ON

No

Yes

Replace Fan

Enter the TEST 2 MODE

Does the cold-air coming out of the top of the main duct.?



Yes

No

Check the Damper itself

Checking Damper itself

Is the resistance Values between (1) & (4), (2) & (3) like as below?

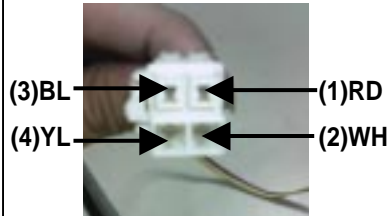

Resistance of Damper

Test Point	Result
(1) to (4)	373 ~456 Ω
(2) to (3)	373 ~456 Ω

Yes

Yes

Replace Damper

Enter the TEST 3 MODE

Is the voltage between Pins 4 and pin 12 of CON3 like as below?

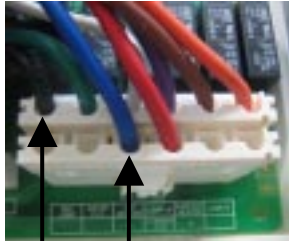

Pin12 BK
Pin4 BL
CON3

Voltage of Compressor

Test Point	Result
pin4 to pin12	115 V

Yes

Yes

Replace Damper

After reset the unit, take steps to PCB as follows for temperature compensation.

1. In the case of 6871JB1431 (by July 2007)
: Compensate with replacing RCR1





RCR1	Temp. Compension	Result
180 k‰	+ 2.5 deg	Current
56 k‰	+ 2 deg	 Colder
33 k‰	+ 1.5 deg	
18 k‰	+ 1 deg	
12 k‰	+ 0.5 deg	

*** Change RCR1**

2. In the case of EBR34917102 (from Aug 2007)
: Compensate with Jump wire cutting



JUMP WIRE	Temp. Compensation
	+ 1.0 deg
	+ 1.0 deg
Cutting both jumpers affords a 2... temperature compensation	

*** Cutting of jumper wire**

(NOTE)

1. How To Remove Terminal Position Assurance (TPA)

* AC TPA



* DC TPA

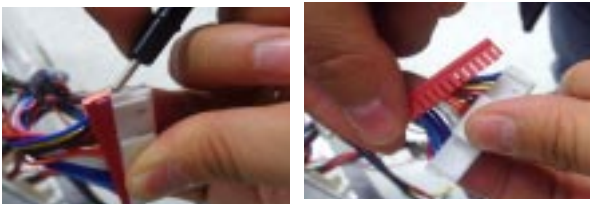

After measure the values,
you should put in the TPA again.

2. Wire Color

BL : Blue
WH : White
BO : Bright Orange
BK : Black
BN : Brown
PR : Purple
RD : Red
GN : Green
SB : Sky Blue
GY : Gray

3. How To Start Test Mode

Push the TEST button on the Main PWB,
You can start the TEST MODE.

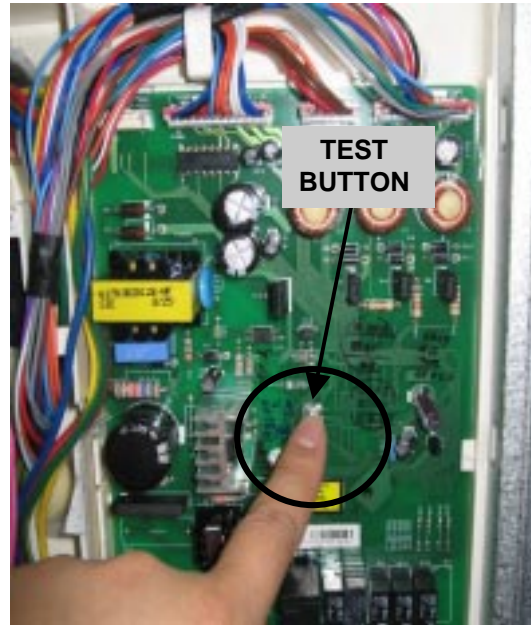

* 1 time : Comp / Damper / All FAN on,
(All things displayed)

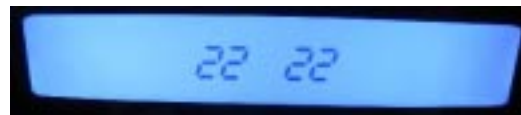

* 2 times : Damper closed
(22 22 displayed)

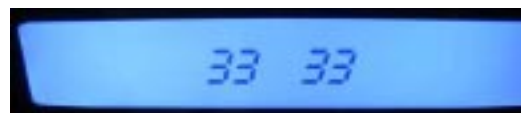

* 3 times : Forced forced defrost mode
(33 33 displayed)

4. How to check the Fan-Error

(1) 6871JB1431A (~ July 2007)

After sending a signal to the fan, the MICOM checks the BLDC fan motor's lock status. If there is no feedback signal from the BLDC fan, the fan motor stops for 10 seconds and then is powered again for 15 seconds. To determine that there is a fan motor malfunction, this process is repeated 5 times. If the fan motor is determined to be defective, the error code will be shown continuously in the display. At this point, there is no further check of the fan motor.

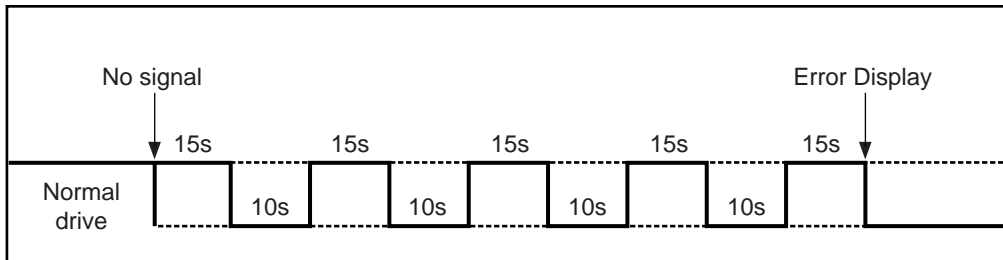

(2) EBR34917102 (Aug 2007 ~)

After sending a signal to the fan, the MICOM checks the BLDC fan motor's lock status. If there is no feedback signal from the BLDC fan, the fan motor stops for 10 seconds and then is powered again for 15 seconds. To determine that there is a fan motor malfunction, this process is repeated 3 times. If the fan motor is determined to be defective, the error code will be shown in the display for 30 minutes. At this point, the process will be repeated until the fan motor operates normally. If normal operation is achieved, the error display is erased and the MICOM is reset automatically.

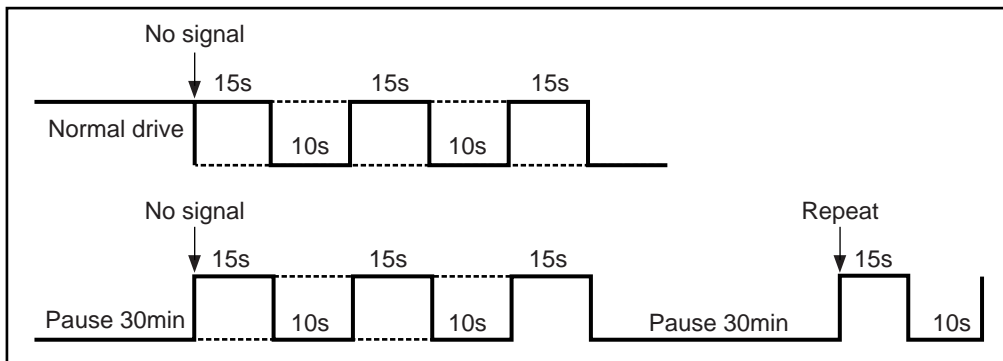

7. COMPONENT TESTING INFORMATION

7-1. Defrost Controller Assembly

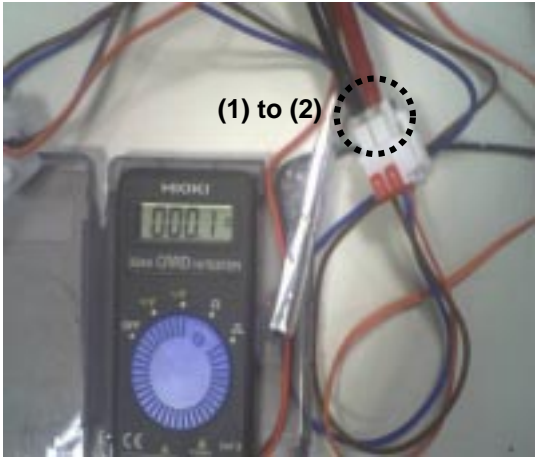
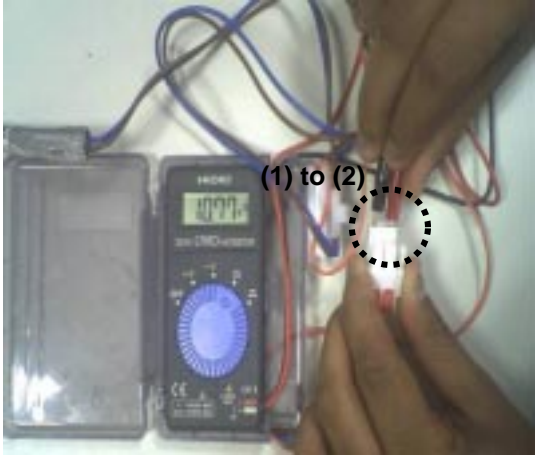
<p>Function</p>	<ul style="list-style-type: none"> - Controller assembly is consist of 2 kinds of part those are fuse-m and sensor. we can decide part is defect or not when we check the resistance. - Fuse-m can cut off the source when defrost heater operate the unusual high temperature. - Sensor give temperature information to Micom 									
<p>How to Measure (Fuse-M)</p>		<p>Set a ohmmeter to the 2 housing pin. Measure the 2 pin connected to Fuse-M. If the ohmmeter indicate below 0.1ohm fuse-m is a good condition, But infinitely great ohm Fuse-M is disconnection</p>								
<p>How to Measure (Sensor)</p>		<p>Set a ohmmeter to The 2housing pin. Measure the 2 pin connected to Sensor. If the ohmmeter indicate 11kΩ (at room temperature) Sensor is not a defect. When check the ohm at other temperature Check the sensor manual.</p>								
<p>Standard</p>	<p>Fuse-M (at all temperature)</p> <table border="1" data-bbox="435 1647 833 1747"> <thead> <tr> <th>Test Point</th> <th>Result</th> </tr> </thead> <tbody> <tr> <td>(1) to (2)</td> <td>0 ~0.1 Ω</td> </tr> </tbody> </table>	Test Point	Result	(1) to (2)	0 ~0.1 Ω	<p>Sensor (at room temperature)</p> <table border="1" data-bbox="967 1647 1365 1747"> <thead> <tr> <th>Test Point</th> <th>Result</th> </tr> </thead> <tbody> <tr> <td>(1) to (2)</td> <td>11 Ω</td> </tr> </tbody> </table>	Test Point	Result	(1) to (2)	11 Ω
Test Point	Result									
(1) to (2)	0 ~0.1 Ω									
Test Point	Result									
(1) to (2)	11 Ω									

7-2. Sheath Heater

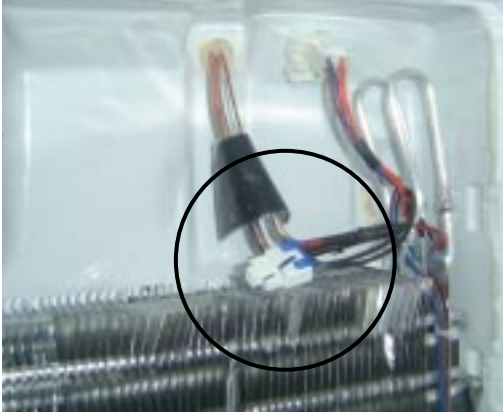
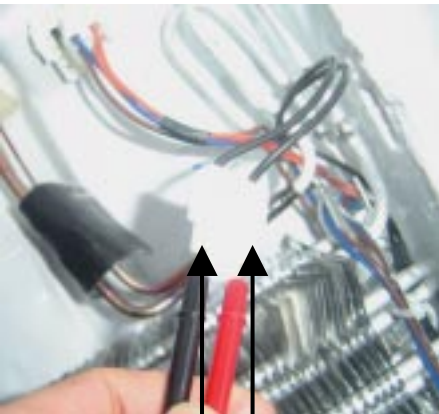
<p>Function</p>	<p>Sheath heater is a part for defrost. All heating wire is connected to only one line. So we can decide part is defect or not when we check the resistance.</p>				
<p>How to Measure</p>	<div style="display: flex; justify-content: space-around;">   </div> <p>Set a ohmmeter connect to The 2 housing pin. Measure the 2 pin connected to Sheath Heater. If the ohmmeter indicate $(V^{\circ}V)/Watt=R$ is good condition, ex) when watt=350w, voltage=115v $R=(115^{\circ}115)/350=38\Omega$ But the ohmmeter indicate infinitely great Sheath heater is disconnection</p>				
<p>Standard</p>	<p>Sheath heater (at all temperature)</p> <table border="1" data-bbox="435 1427 834 1527"> <thead> <tr> <th>Test Point</th> <th>Result</th> </tr> </thead> <tbody> <tr> <td>(1) to (2)</td> <td>34 ~42 Ω</td> </tr> </tbody> </table>	Test Point	Result	(1) to (2)	34 ~42 Ω
Test Point	Result				
(1) to (2)	34 ~42 Ω				



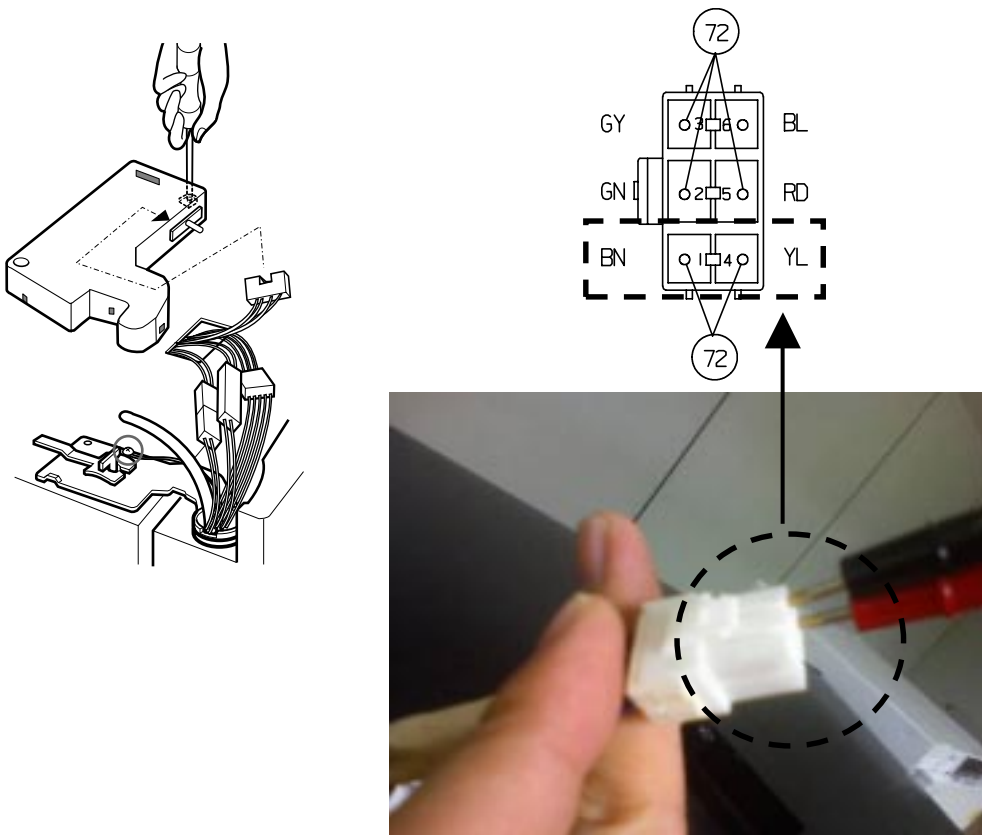

7-3. Door Heater Assembly

<p>Function</p>	<p>The heater is designed to prevent the raising dew from door.</p>				
<p>How to Measure</p>					
<p>Standard</p>	<table border="1" data-bbox="435 1421 834 1519"> <thead> <tr> <th>Test Point</th> <th>Result</th> </tr> </thead> <tbody> <tr> <td>(1) to (2)</td> <td>2.3 ~2.9 Ω</td> </tr> </tbody> </table>	Test Point	Result	(1) to (2)	2.3 ~2.9 Ω
Test Point	Result				
(1) to (2)	2.3 ~2.9 Ω				

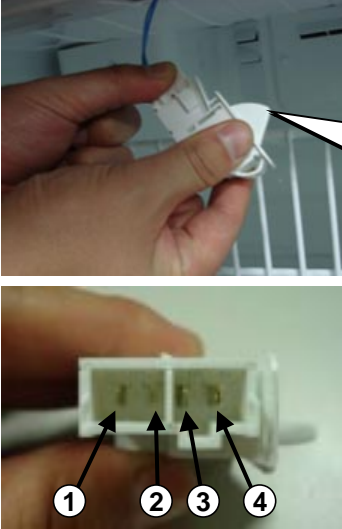
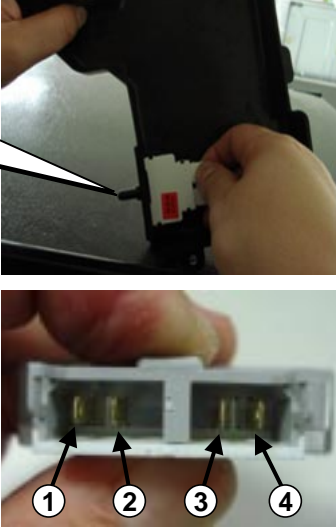
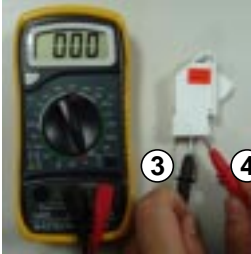

7-4. Door Switch

<p>Function</p>	<p>The switch sense if the door open or close.</p> <ul style="list-style-type: none"> - When the door open, lamp on. - When the door open, the switch give information to Micom. <p>When the door open, internal contact operate on and off moving plunger of door switch up and down.</p>				
<p>How to Measure</p>	<div style="display: flex; justify-content: space-around;"> <div style="text-align: center;"> <p><Switch, Freezer></p>  </div> <div style="text-align: center;"> <p><Switch, Refrigerator></p>  </div> </div> <div style="display: flex; justify-content: space-around; margin-top: 20px;"> <div style="text-align: center;">  <p>Beep</p> </div> <div style="text-align: center;">  <p>Beep</p> </div> </div> <p>Check the resistance between connectors 1,2 and 3,4 .It means check whether or not applying an electric current. If there is resistance, it means the switch not inferiority</p>				
<p>Standard</p>	<p>Multimeter beep – Switch F,R</p> <table border="1" style="width: 100%; border-collapse: collapse;"> <tr> <td style="width: 50%; text-align: center;">Nomal</td> <td style="width: 50%; text-align: center;">Push the button(Plunger)</td> </tr> <tr> <td style="text-align: center;">Beep or 0 Ω</td> <td style="text-align: center;">None (∞ Ω)</td> </tr> </table>	Nomal	Push the button(Plunger)	Beep or 0 Ω	None (∞ Ω)
Nomal	Push the button(Plunger)				
Beep or 0 Ω	None (∞ Ω)				

7-5. Solenoid

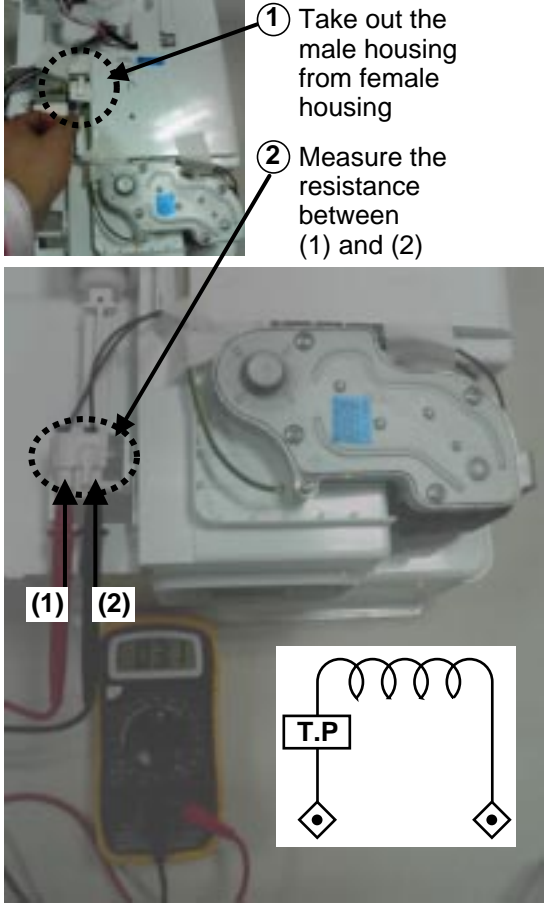
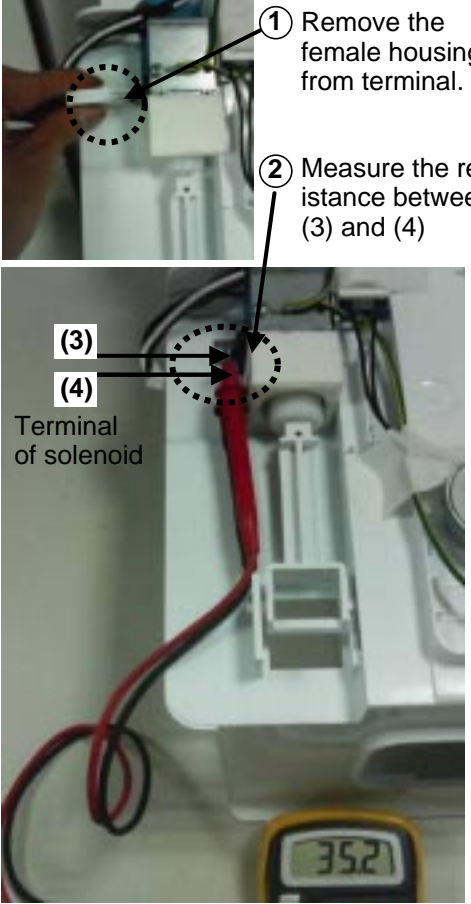

<p>Function</p>	<p>- Dispenser solenoid : When customer push the dispenser button, Pull duct door and abstract from ice bank.</p>				
<p>How to Measure</p>	<div style="text-align: center;">  <p>Dispenser Solenoid</p> </div>				
<p>Standard</p>	<p style="text-align: center;">Dispenser Solenoid</p> <table border="1" style="margin-left: auto; margin-right: auto;"> <thead> <tr> <th>Test Points</th> <th>Result</th> </tr> </thead> <tbody> <tr> <td>(1) to (2)</td> <td>44 ~ 54 Ω</td> </tr> </tbody> </table>	Test Points	Result	(1) to (2)	44 ~ 54 Ω
Test Points	Result				
(1) to (2)	44 ~ 54 Ω				

7-6. AC Motor ASSEMBLY (Geared Motor & Solenoid)

<p>Function</p>	<p>The Geared Motor of ac motor assembly advances forward the ice by rotating the ice and The solenoid of ac motor assembly selects one of the cube mode or crush mode.</p> <p>- Cube solenoid : Pulling the stir lip for moving the ice in ice maker system.</p>									
<p>How to Measure</p>	<p>< Geared Motor ></p>  <ol style="list-style-type: none"> ① Take out the male housing from female housing ② Measure the resistance between (1) and (2) 	<p>< Cube Solenoid ></p>  <ol style="list-style-type: none"> ① Remove the female housing from terminal. ② Measure the resistance between (3) and (4) <p>(3) (4) Terminal of solenoid</p>								
<p>Check the resistance between connectors (Geared motor 1,2) and (solenoid 3,4).It means check whether or not applying an Electric current. If there is resistance, it means the geared motor or solenoid is not inferiority</p>										
<p>Standard</p>	<p style="text-align: center;">Geared Motor</p> <table border="1" style="margin-left: auto; margin-right: auto;"> <thead> <tr> <th>Test Points</th> <th>Result</th> </tr> </thead> <tbody> <tr> <td>(1) to (2)</td> <td>2.38 ~ 4.02 Ω</td> </tr> </tbody> </table>	Test Points	Result	(1) to (2)	2.38 ~ 4.02 Ω	<p style="text-align: center;">Cube Solenoid</p> <table border="1" style="margin-left: auto; margin-right: auto;"> <thead> <tr> <th>Test Points</th> <th>Result</th> </tr> </thead> <tbody> <tr> <td>(3) to (4)</td> <td>32 ~ 40 Ω</td> </tr> </tbody> </table>	Test Points	Result	(3) to (4)	32 ~ 40 Ω
Test Points	Result									
(1) to (2)	2.38 ~ 4.02 Ω									
Test Points	Result									
(3) to (4)	32 ~ 40 Ω									

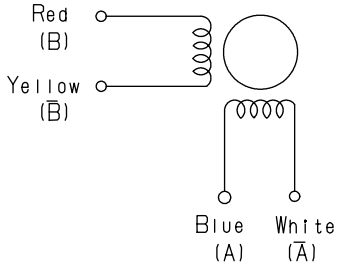
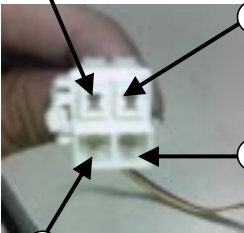

7-7. Damper

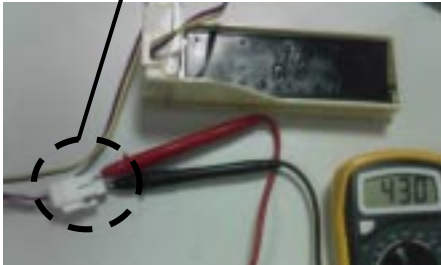
<p>Function</p>	<p>The damper supplies the cold air at freezer room to chillroom by using the damper's plate. Chillroom is colder than before when damper's plate is open. When damper's plate is close, chillroom's temperature will rise.</p>																													
<p>How to Measure</p>	<div style="display: flex; justify-content: space-around;"> <div data-bbox="435 527 852 921" style="border: 1px dashed gray; padding: 5px;"> <p>Table(1): 결선도(Wiring)</p>  </div> <div data-bbox="889 527 1365 857" style="border: 1px dashed gray; padding: 5px;"> <p>Table(2): 2-2상 여자순서(CW Rotation)</p> <table border="1" style="width: 100%; border-collapse: collapse; text-align: center;"> <thead> <tr> <th rowspan="2">Housing No. & L/Wire Color</th> <th colspan="4">Step</th> </tr> <tr> <th>1</th> <th>2</th> <th>3</th> <th>4</th> </tr> </thead> <tbody> <tr> <td>1- Blue (A)</td> <td>+</td> <td>-</td> <td>-</td> <td>+</td> </tr> <tr> <td>2- Red (B)</td> <td>+</td> <td>+</td> <td>-</td> <td>-</td> </tr> <tr> <td>3- White (A)</td> <td>-</td> <td>+</td> <td>+</td> <td>-</td> </tr> <tr> <td>4- Yellow (B)</td> <td>-</td> <td>-</td> <td>+</td> <td>+</td> </tr> </tbody> </table> </div> </div> <p style="text-align: center;">< Damper Circuit ></p> <div style="display: flex; justify-content: space-around;"> <div data-bbox="435 953 824 1613" style="text-align: center;">  <p>① Blue ② Red ③ White ④ Yellow</p>  <p>Check the ②, ④</p> </div> <div data-bbox="963 942 1404 1613" style="text-align: center;">  <p>① Blue ③ White</p> <p>Check the ①, ③ extension</p>  <p>Check the ①, ③</p> </div> </div> <p>Check the resistance between connectors 1,3 and 2,4 .It means check whether or not applying an electric current. If there is resistance, it means the damper not inferiority</p>	Housing No. & L/Wire Color	Step				1	2	3	4	1- Blue (A)	+	-	-	+	2- Red (B)	+	+	-	-	3- White (A)	-	+	+	-	4- Yellow (B)	-	-	+	+
Housing No. & L/Wire Color	Step																													
	1	2	3	4																										
1- Blue (A)	+	-	-	+																										
2- Red (B)	+	+	-	-																										
3- White (A)	-	+	+	-																										
4- Yellow (B)	-	-	+	+																										
<p>Standard</p>	<p>Damper</p> <table border="1" style="width: 100%; border-collapse: collapse; text-align: center;"> <thead> <tr> <th>Test Points</th> <th>Result</th> </tr> </thead> <tbody> <tr> <td>Red and Yellow</td> <td>373 ~ 456 Ω</td> </tr> </tbody> </table> <table border="1" style="width: 100%; border-collapse: collapse; text-align: center;"> <thead> <tr> <th>Test Points</th> <th>Result</th> </tr> </thead> <tbody> <tr> <td>Blue and White</td> <td>373 ~ 456 Ω</td> </tr> </tbody> </table>	Test Points	Result	Red and Yellow	373 ~ 456 Ω	Test Points	Result	Blue and White	373 ~ 456 Ω																					
Test Points	Result																													
Red and Yellow	373 ~ 456 Ω																													
Test Points	Result																													
Blue and White	373 ~ 456 Ω																													

7-8. Lamp Socket

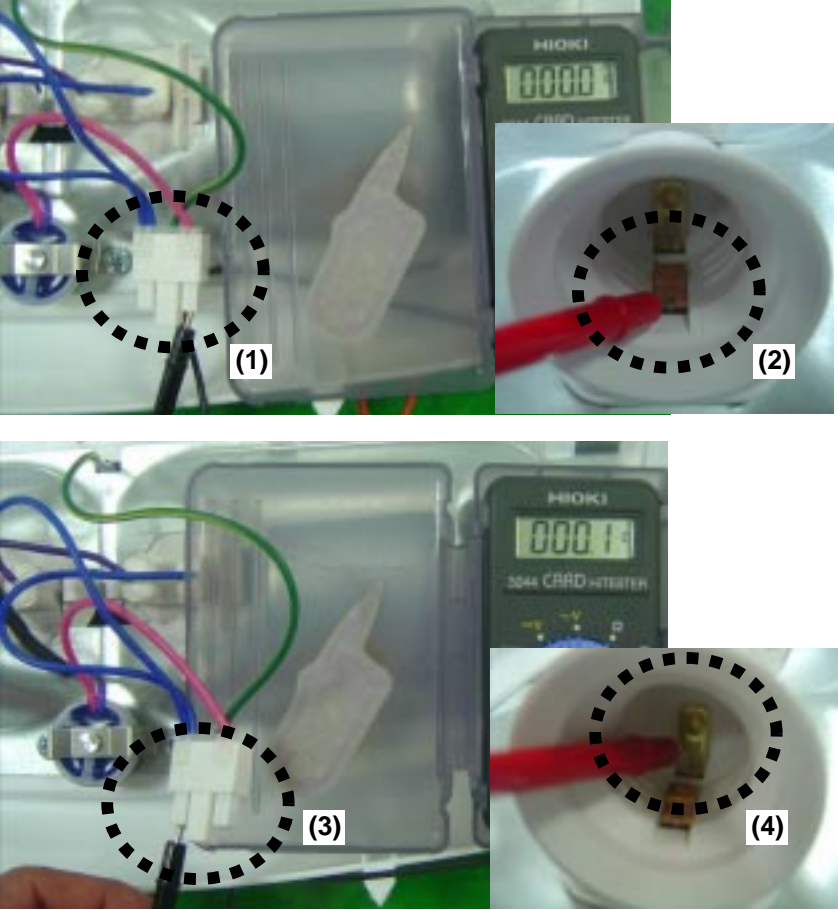
<p>Function</p>	<p>The lamp socket connect cover lamp assembly to lamp. The lamp socket fix lamp and unite lamp and cover lamp assembly. The lamp socket supply electric source to lamp also.</p>				
<p>How to Measure</p>	<div style="text-align: center;">  </div> <p>Check the resistance between connector of housing and connector of lamp socket. It means check whether or not applying an electric current. If there is resistance it means the lamp socket is not inferiority.</p>				
<p>Standard</p>	<table border="1" style="margin-left: auto; margin-right: auto;"> <thead> <tr> <th>Test Points</th> <th>Result</th> </tr> </thead> <tbody> <tr> <td>(1) to (2) and (3) to (4)</td> <td>0 Ω</td> </tr> </tbody> </table>	Test Points	Result	(1) to (2) and (3) to (4)	0 Ω
Test Points	Result				
(1) to (2) and (3) to (4)	0 Ω				

7-9. Water Valve

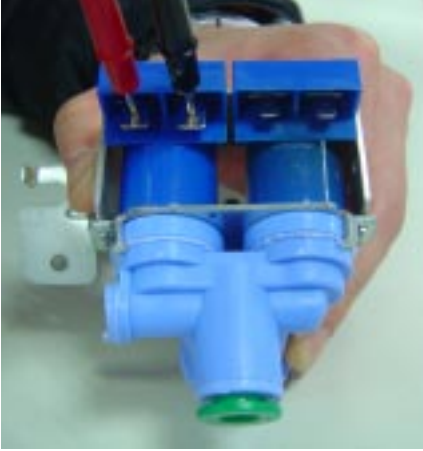
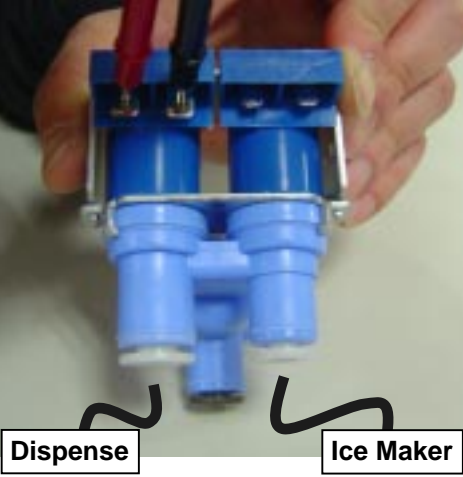
<p>Function</p>	<ul style="list-style-type: none"> - first-Water Valve (in machine room) : supply the water from city water to water filter in refrigerator - second-Water Valve (in door) : supply the water from water filter to icemaker and dispenser 				
<p>How to Measure</p>	<div style="display: flex; justify-content: space-around; align-items: flex-end;"> <div style="text-align: center;">  <p>First-water valve (in machine room)</p> </div> <div style="text-align: center;">  <p>second-water valve (in door)</p> </div> </div>				
<p>Standard</p>	<table border="1" style="margin-left: auto; margin-right: auto;"> <thead> <tr> <th>Test Points</th> <th>Result</th> </tr> </thead> <tbody> <tr> <td>(1) to (2)</td> <td>360 ~ 420 Ω</td> </tr> </tbody> </table>	Test Points	Result	(1) to (2)	360 ~ 420 Ω
Test Points	Result				
(1) to (2)	360 ~ 420 Ω				

8. DISASSEMBLY INSTRUCTIONS

8-1 REMOVING AND REPLACING REFRIGERATOR DOORS

● Removing Refrigerator Door

▲ **CAUTION:** Before you begin, unplug the refrigerator. Remove food and bins from doors.

▶ Left Door - Figure 2

2. Open the door. Loosen the top hinge cover screw (1).
Use a flat tip screwdriver to pry back hooks on front underside of the cover (3). Lift up the cover.
3. Disconnect the door switch wire harness (2). Remove the cover.
4. Pull out the tube.
5. Disconnect the three wire harnesses (5). Remove the grounding screw (6).
6. Rotate the hinge lever (7) counterclockwise and remove. Lift the top hinge (8) free of the hinge lever latch (9).

▲ **CAUTION:** When lifting the hinge free of latch, be careful that the door does not fall forward.

7. Lift the door up from the middle hinge pin and remove the door.
8. Place the door, inside facing up, down onto a non-scratching surface.

▶ Right Door - Figure 3

1. Open the door. Loosen the top hinge cover screw (1). Lift up the cover (3).
 2. Disconnect the door switch wire harness (2). Remove the cover.
 3. Disconnect the wire harness (5). Remove the grounding screw (6).
 4. Rotate the hinge lever (7) clockwise and remove. Lift the top hinge (8) free of the hinge lever latch (9).
- CAUTION: When lifting the hinge free of the latch, be careful that the door does not fall forward.
5. Lift the door up from middle hinge pin (10) and remove the door.
 6. Place the door, inside facing up, down onto a non-scratching surface.

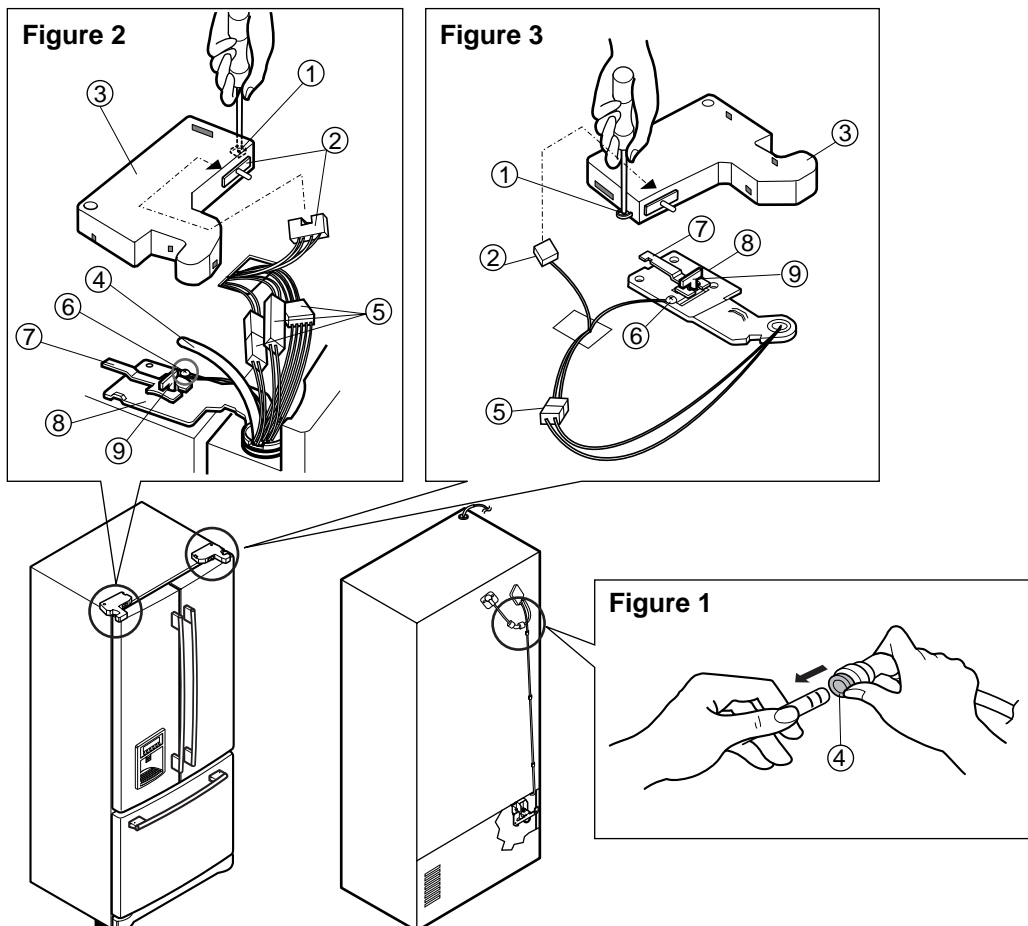

8-2 DOOR

● Door Gasket Removal

1. Remove door frame cover

Starting at the top of cover and working down, snap the cover out and away from the door.

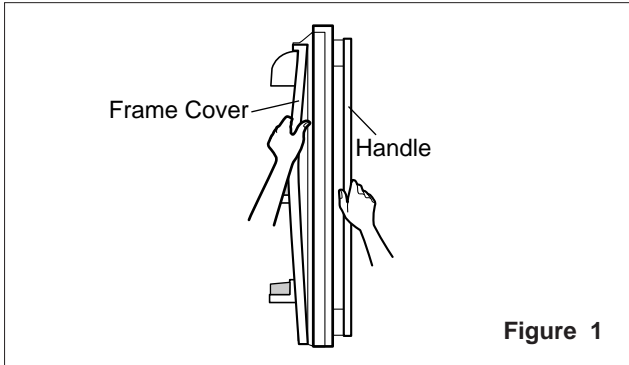

2. Remove gasket bracket clips

There are two clips on each door. Start the bracket removal near one of the middle clips.

- 1) Pull the gasket back to expose the gasket bracket clip and door frame.
- 2) Insert a flat tip screwdriver into the seam between the gasket bracket and the door frame and pry back until the clips snap out.
- 3) Continue prying back along the seam until all clips snap out.

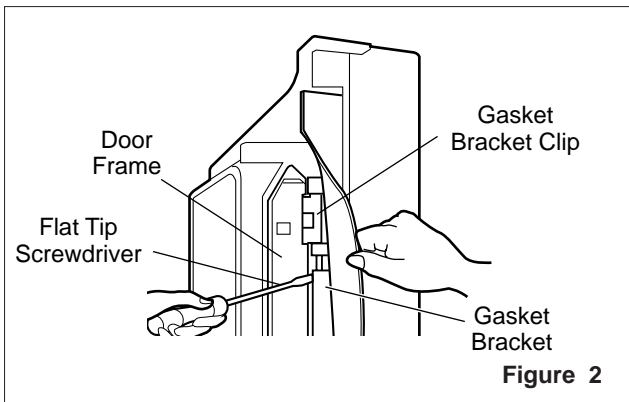

3. Remove gasket

Pull the gasket free from the gasket channel on the three remaining sides of door.

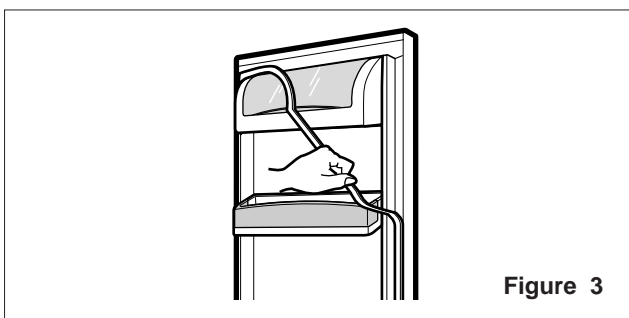

● Door Gasket Replacement

1. Insert gasket bracket clips

- 1) Insert the gasket bracket edge beneath the door frame edge.
- 2) Turn the upper gasket bracket spring so that the spring ends are in the door channel.
- 3) Push in the clip until you hear it snap securely into place.

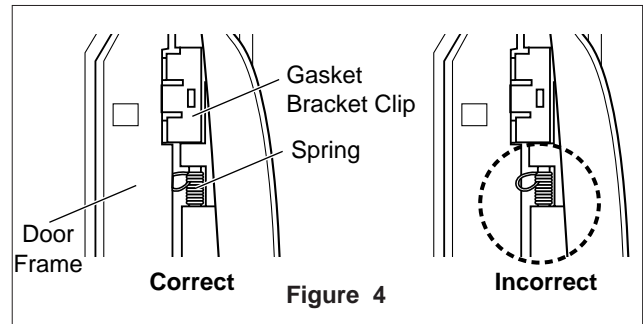

- 4) Push in the remaining clip until you hear it snap securely into place.

Note: Make sure that no part of the gasket bracket edge protrudes from beneath the door frame edge.

2. Insert gasket into channel

- 1) Snap the gasket assembly into the door bracket.

Inserting the Gasket Assembly into the Bracket Door

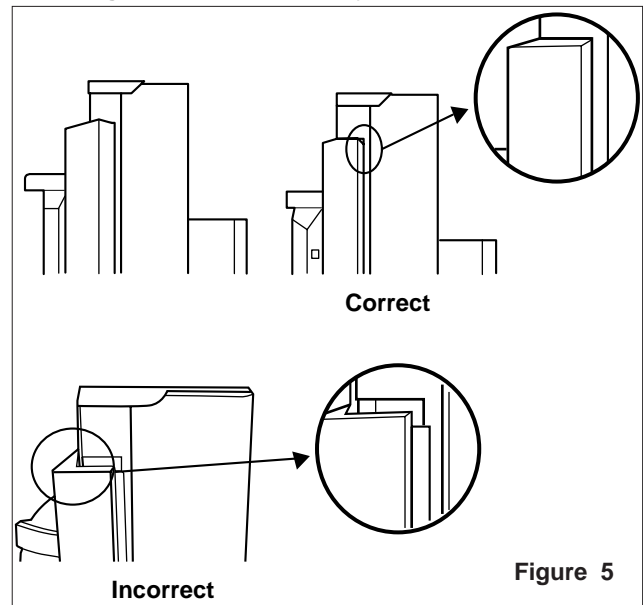

- 2) Press the gasket into the channels on the three remaining sides of door.

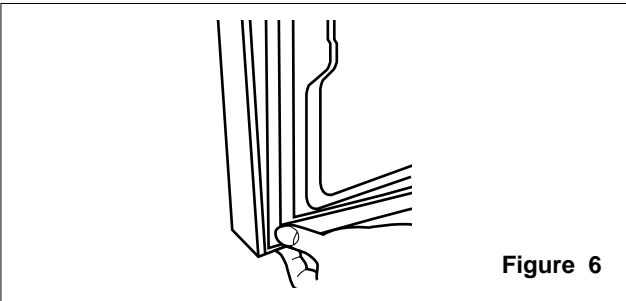

Figure 6

3. Replace door frame cover

Starting at the top of the cover and working down, snap the cover back into door.

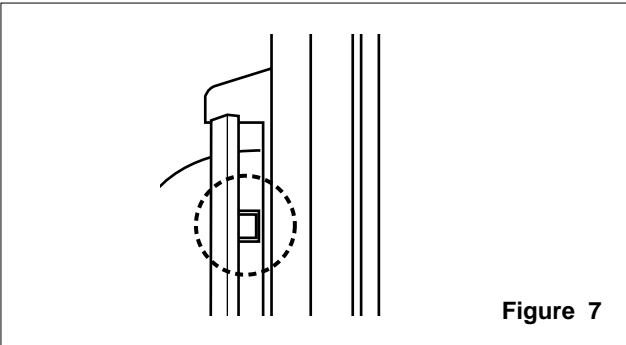

Figure 7

8-3 DOOR ALIGNMENT

If the space between your doors is uneven, follow the instructions below to align the doors:

1. With one hand, lift up the door you want to raise at the middle hinge.
2. With the other hand, use pliers to insert the snap ring as shown.
3. Insert additional snap rings until the doors are aligned. (Three snap rings are provided with unit.)

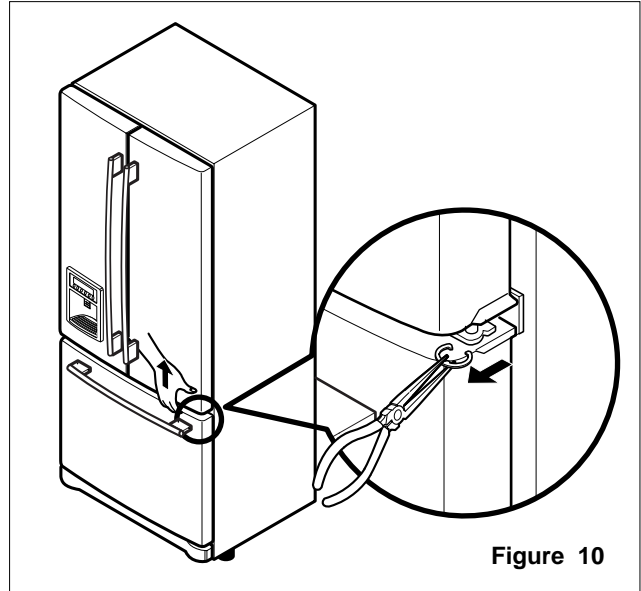

Figure 10

8-4 FAN AND FAN MOTOR (EVAPORATOR)

1. Remove the freezer shelf.
2. Remove the plastic guide for the slides on left side by unscrewing the phillips head screws.
3. Remove the grille by removing one screw and pulling the grille forward.
4. Remove the Fan Motor assembly by loosening 2 screws and disassembling the shroud.
5. Pull out the fan and separate the Fan Motor and Bracket.

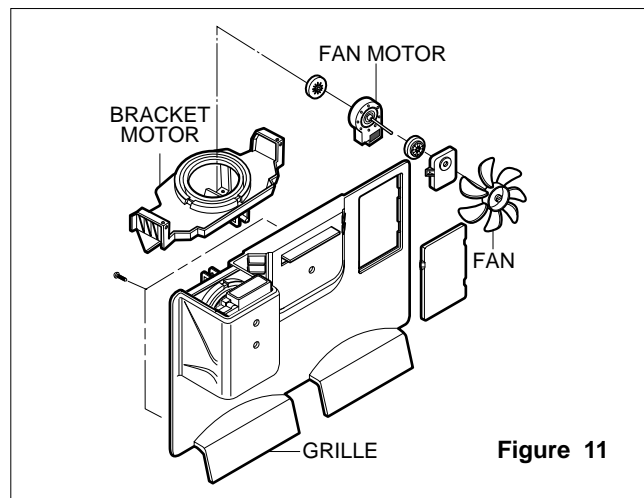

Figure 11

* Ice Fan Scroll Assembly Replacement

- 1) Remove the plastic guide for the slides on left side by unscrewing the phillips head screws.
- 2) Pull the grille forward as shown in the second picture.
- 3) Disconnect the wire harness of the grille
- 4) Remove the scroll assembly by loosening 2 screws



(1)



(2)



(3)



(4)

8-5 DEFROST CONTROL ASSEMBLY

The defrost Control assembly consists of the Defrost Sensor and the FUSE-M.

The Defrost Sensor works to defrost automatically. It is attached to the metal side of the Evaporator and senses its temperature. At 72°C, it turns the Defrost Heater off. Fuse-M is a safety device for preventing overheating of the Heater when defrosting.

1. Pull out the grille assembly. (Figure 12)
2. Separate the connector with the Defrost Control assembly and replace the Defrost Control assembly after cutting the Tie Wrap. (Figure 13)

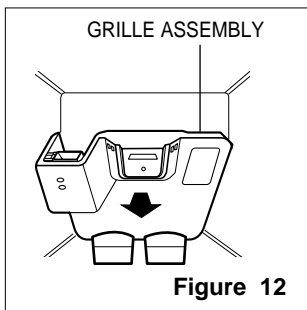

Figure 12

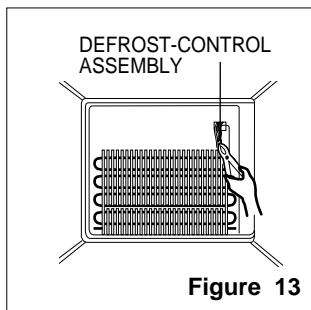

Figure 13

8-6 LAMP

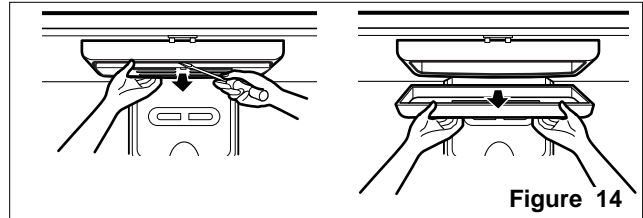

Figure 14

8-6-1 Refrigerator Compartment Lamp

1. Unplug the Refrigerator or disconnect power at the circuit breaker.
2. If necessary, remove the top shelf or shelves.
3. Using a flat instrument, gently pry the cover loose in the front as shown. Rotate downward to remove rear tabs.
4. Make sure the bulbs are cool to the touch. Turn bulbs counterclockwise to remove.
5. Assemble in reverse order by snapping the Lamp Cover in, engaging the rear tabs followed by the front tabs. (Max. 60 W-2EA)

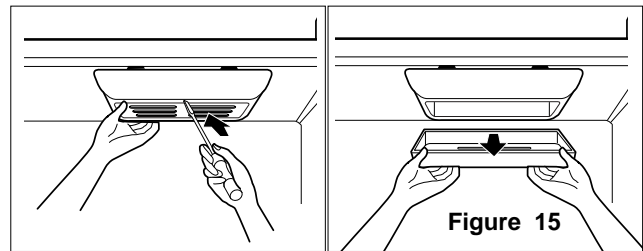

Figure 15

8-6-2 Freezer Compartment Lamp

1. Unplug refrigerator power cord form outlet.
2. Using a flat instrument, gently pry the lamp cover loose in the front as shown. Rotate downward to remove the rear tabs.
3. Make sure the bulb is cool to the touch. Turn the bulb counterclockwise to remove.
4. Replace with a new 60-watt appliance bulb.
5. Insert tabs on back of cover into slots in freezer ceiling. Push cover up to snap front into place.

8-7 CONTROL BOX-REFRIGERATOR

1. First, remove all shelves in the refrigerator, than remove the Refrigerator control Box by loosening 2 screws.

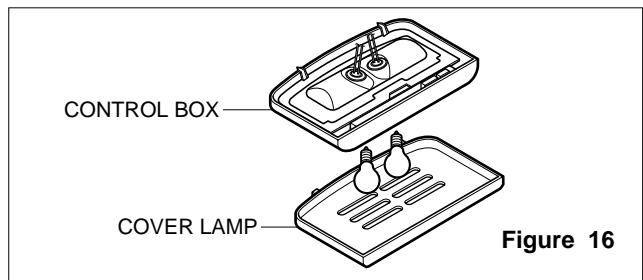
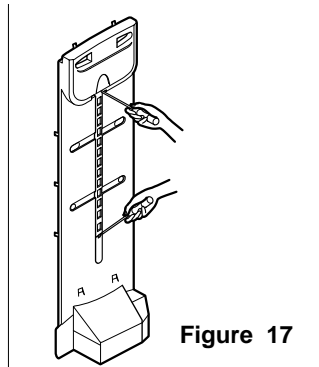

Figure 16

2. Remove the Refrigerator Control Box by pulling it downward.
3. Disconnect the lead wire on the right position and separate the lamp sockets.

8-8 MULTI DUCT

- 1) Remove the upper and lower caps by using a flat screwdriver, and remove 2 screws. (Figure 17)
- 2) Disconnect the lead wire on the bottom position.



8-9 MAIN PWB

- 1) Loosen the 3 screws on the PCB cover.



- 2) Remove the PCB cover



- 3) Disconnect wire harness and replace the main PCB in the reverse order of removal.



8-10 DISPENSER

- 1) Disconnect the funnel and button assembly by pulling down and forward.



- 2) Remove display frame assembly by making a gap between the display frame assembly and door with a flat blade screwdriver and pulling it forward. The cover dispenser is attached with a hook.



- CAUTION:** When replacing the dispenser cover in the reverse order of removal, be careful that the lead wire does not come out and the water tube is not pinched by the dispenser cover, as shown in the picture below.

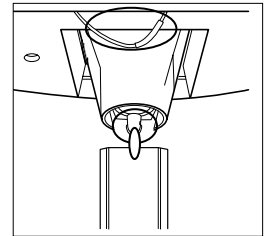

8-11 DISPLAY PCB REPLACEMENT

- 1) Pull up and out on the dispenser cover to remove.



- 2) Follow the steps in the pictures



8-12 FUNNEL REPLACEMENT

- 1) Pull up and out on the dispenser cover to remove.
- 2) Disconnect the wire harness.
- 3) Replace in reverse order.



8-13 SUB PWB FOR WORKING DISPENSER

- 1) Loosen the screw on the sub PCB.



- 2) Pull the sub PCB down.
- 3) Disconnect the wire harness and replace the sub PCB in the reverse order of removal.



8-14 DUCT DOOR REPLACEMENT

- 1) Pull up and out on the dispenser cover to remove.
- 2) Disconnect the wire harness.
- 3) Remove the funnel
- 4) Replace in reverse order.



8-15 ICE CORNER DOOR REPLACEMENT

- 1) Loosen the front screw as shown in the picture.
- 2) Lift up the hinge with one hand.
- 3) Pull out the Ice Corner Door with the other hand.



8-16 ICEMAKER ASSEMBLY

- 1) Loosen two screws as shown in the first picture.



- 2) Disconnect the wire harness and ground screw replace the icemaker assembly in the reverse order of removal.



- 3) Remove the ground connection screw.



8-17 AUGER MOTOR COVER

- 1) After removing the icemaker remove the (5) stainless screws holding the auger motor cover, shown in the pictures below.

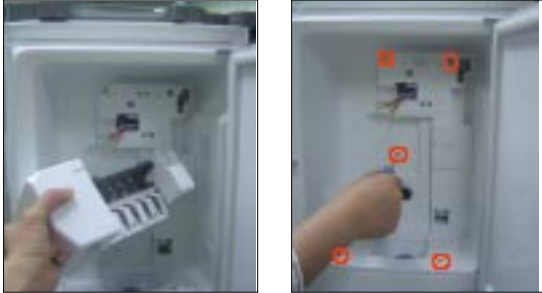

- 2) Grip the bottom of the motor cover assembly and pull out it.



- 3) Disconnect the wire harness of the motor cover assembly. There is an auger motor on the back, as shown in the picture.

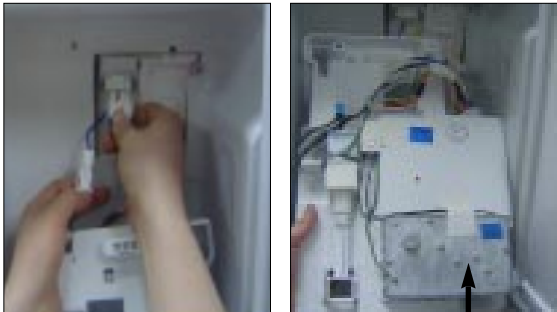

Auger Motor

8-18 HOW TO REMOVE THE DOOR ICE BIN

1) Grip the handles, as shown in the picture.

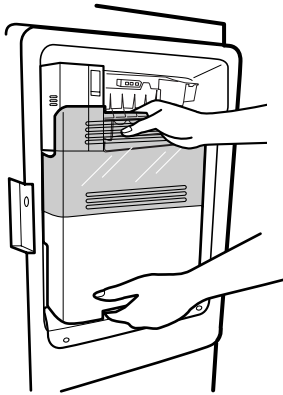

2) Lift the lower part slightly.

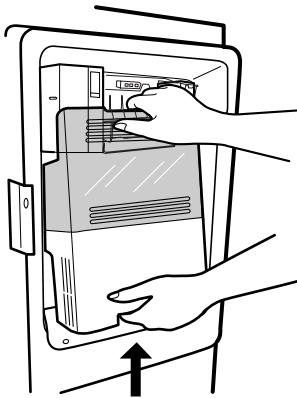

3) Take the ice bin out slowly.

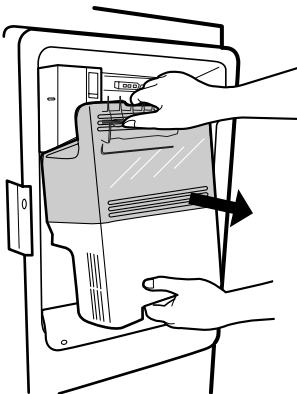

8-19 HOW TO INSERT THE DOOR ICE BIN

1) Insert the Ice Bin, slightly tilting it to avoid touching the icemaker, particularly the feeler arm lever.

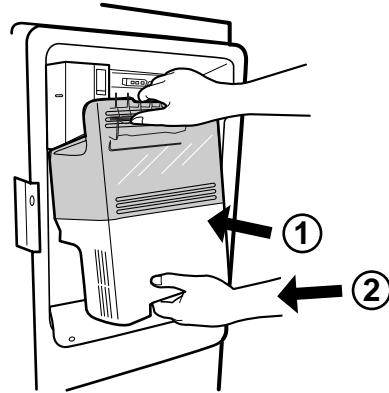

※ Insert the ice bucket carefully avoid contacting the automatic shut off arm.

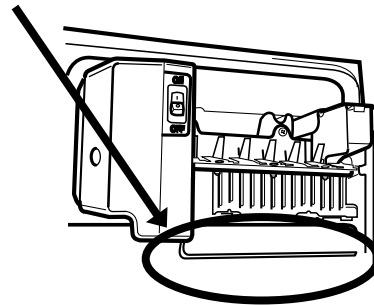

8-20 HOW TO REMOVE AND REINSTALL THE PULLOUT DRAWER

8-20-1 Follow Steps to Remove

Step 1) Open the freezer door.



Step 2) Remove the lower basket.



Step 3) Remove the two screws from the guide rails (one from each side).



Step 4) Lift the freezer door up to unhook it from the rail support and remove. Pull both rails to full extension.



Step 5) First: Remove the gear from the left side first by releasing the tab behind the gear, place a screwdriver between the gear and the tab and pull up on the gear.

Second Remove the center rail.

Third Remove the gear from the right side by following the same steps for the left side.

NOTE: THIS TAB MUST BE PUSHED IN TO RELEASE THE GEAR.

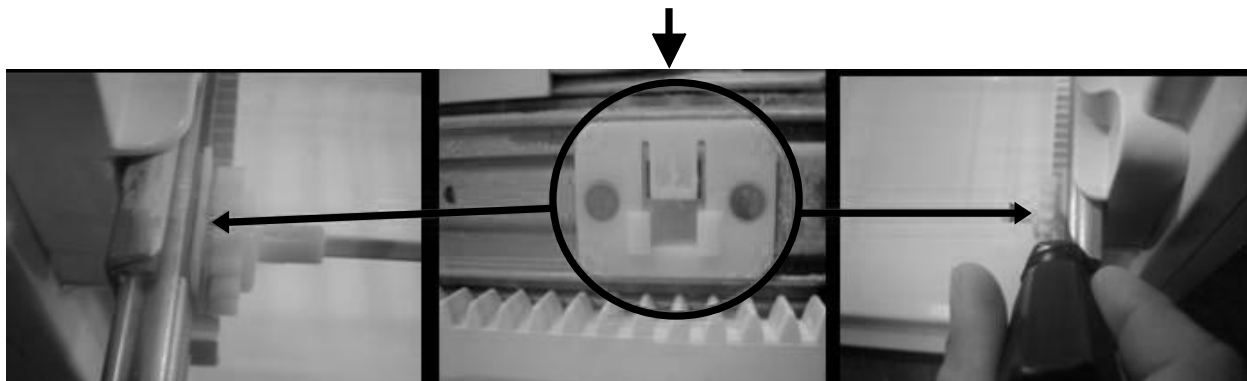

8-20-2 Follow Steps to Reinstall

Step 1) Reinstall the right side gear into the clip.



Step 2) Insert the rail into the right side gear. Gears do **not** need to be perpendicular to each other.



Step 3) Insert the rail into the left side gear, and insert the gear into the clip.



Step 4) The rail system will align itself by pushing the rails all the way into the freezer section. Pull the rails back out to full extension.



Step 5) Reinstall the freezer door by inserting the rail tabs into the guide rail.



Step 6) Reinstall the two screws into the guide rails (one from each side).



Step 7) Reinstall the lower basket, and close the freezer door.



8-21. WATER VALVE DISASSEMBLY METHOD

- 1) Turn off the water. Then separate the water line from the valve.

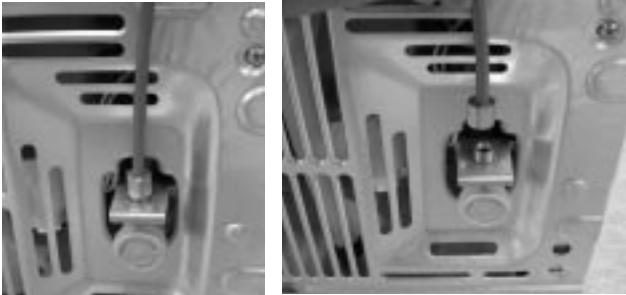

- 2) Separate the mechanical cover and valve screw.

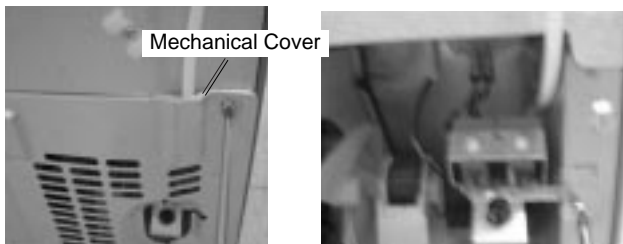

- 3) Separate the housing and pull out the valve.

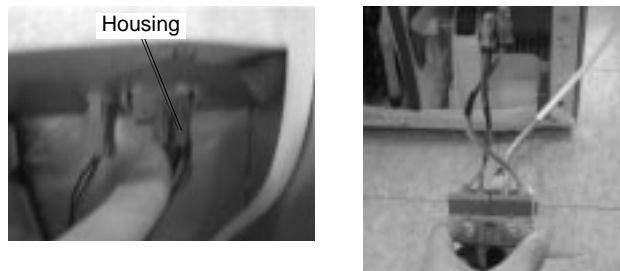

- 4) Lay a dry towel on the floor and get ready to spill water from the water filter. Pull out the clip. Then press the collet to separate the tube from the connector and pour out the water until emptied.

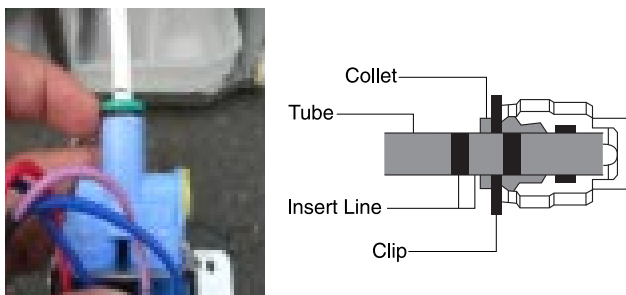

8-22. FAN AND FAN MOTOR DISASSEMBLY METHOD

- 1) Using a short screwdriver, loosen one SCREW in DRAIN PIPE ASSEMBLY and one connected to the MOTOR COVER.



- 2) Pull and separate the FAN ASSEMBLY and MOTOR turning counterclockwise based on the MOTOR SHAFT.

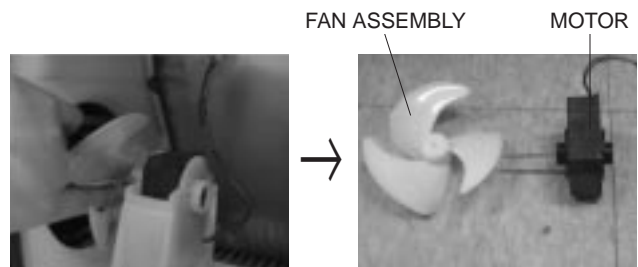

Reassembly is in the reverse order of the disassembly and take special care for the following details.

1. Be careful not to bend the tube during assembly.
2. Press the WATER DISPENSER button until water pours out and check for leakage in the CONNECTOR TUBE (It differs by the water pressure but usually takes about 2 minutes for the water to drain.)

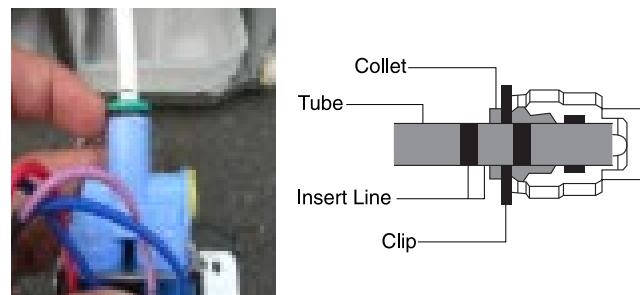

8-23 PULL OUT DRAWER

To separate the drawer, push the front left and right hooks in ① direction to pull up and remove.
Then gently lift the gear part of rear left and right side of the drawer and pull it out in ③ direction.

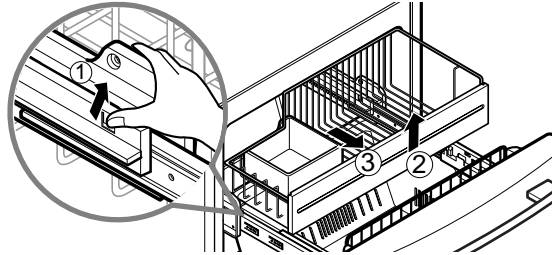

To install, reposition the gear part of rear left and right side of the drawer after pulling out both rails as much as possible, and gently push down both left and right side while checking the hook on the front part.

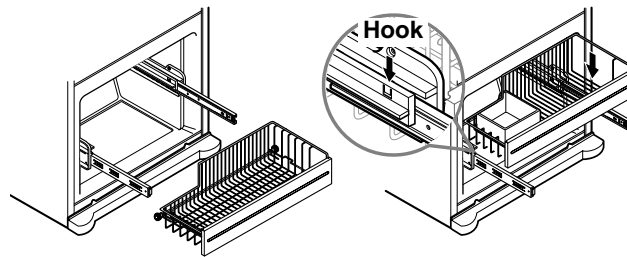

9. PCB ASSEMBLY

9-1. Main PCB Assembly
6871JB1431 (by July 2007)



EBR34917102 (from Aug 2007)



9-2. Display and Dispenser Drive PCB Assembly



Display PCB

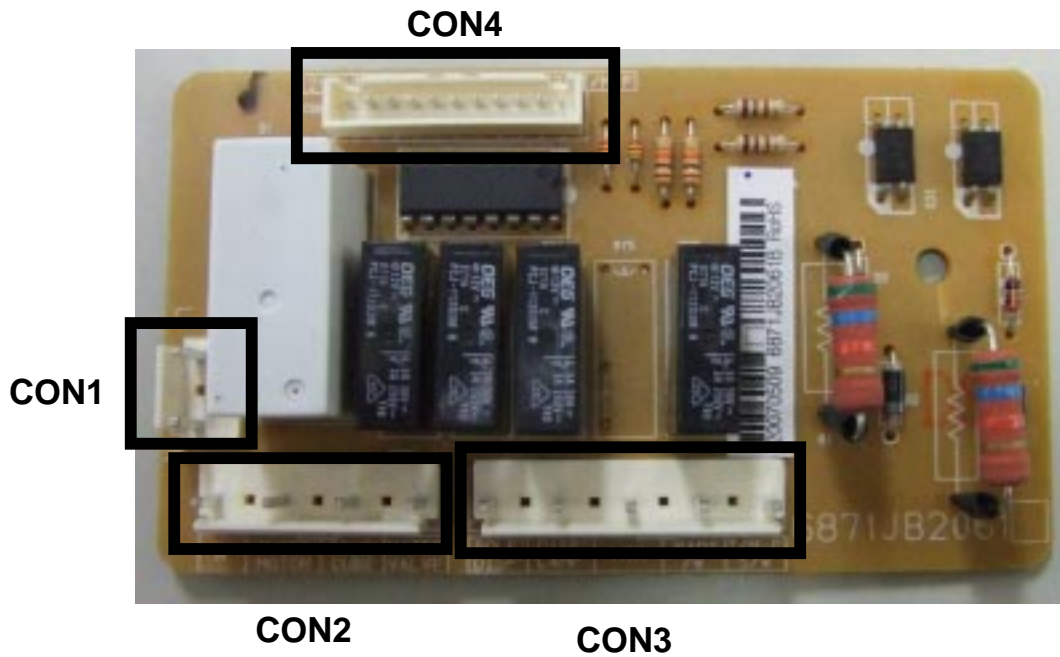

Dispenser PWB





REPAIR PARTS LIST

MODELS No.

795.77562600
 795.77569600
 795.77564600
 795.77563600
 795.77572600
 795.77579600
 795.77573600

The model number of your refrigerator is found on the serial plate inside.

All repair parts listed are available for immediate purchase or special order when you visit your nearest Sears Service Center, or the Service Department at most Sears stores. To order parts by phone, call the toll free parts number listed to the left.

When requesting service or ordering parts, always provide the following information:

- Product Type • Part Number
- Model Number • Part Description

To call Toll Free For Parts:

1-800-366-PART
 (1-800-366-7278)

For Service:

1-800-4-MY-HOME
 (1-800-469-4663)

Last Revision: JJNE. 7. 2007

Sears, Roebuck and Co., Hoffman Estates, IL 60179 U.S.A.

Get it fixed, at your home or ours!

Your Home

For repair—in your home—of all major brand appliances, lawn and garden equipment, or heating and cooling systems, **no matter who made it, no matter who sold it!**

For the replacement parts, accessories and owner's manuals that you need to do-it-yourself.

For Sears professional installation of home appliances and items like garage door openers and water heaters.

1-800-4-MY-HOME® (1-800-469-4663)

Call anytime, day or night (U.S.A. and Canada)

www.sears.com www.sears.ca

Our Home

For repair of carry-in items like vacuums, lawn equipment, and electronics, call or go on-line for the location of your nearest

Sears Parts & Repair Center.

1-800-488-1222

Call anytime, day or night (U.S.A. only)

www.sears.com

To purchase a protection agreement (U.S.A.) or maintenance agreement (Canada) on a product serviced by Sears:

1-800-827-6655 (U.S.A.)

1-800-361-6665 (Canada)

Para pedir servicio de reparación a domicilio, y para ordenar piezas:

1-888-SU-HOGARSM
 (1-888-784-6427)

Au Canada pour service en français:

1-800-LE-FOYERSM
 (1-888-533-6937)
www.sears.ca



® Registered Trademark /™ Trademark /SM Service Mark of Sears, Roebuck and Co.
 ® Marca Registrada /™ Marca de Fábrica /SM Marca de Servicio de Sears, Roebuck and Co.
 MC Marque de commerce /no Marque déposée de Sears, Roebuck and Co.

© Sears, Roebuck and Co.

VALVE & WATER TUBE PARTS

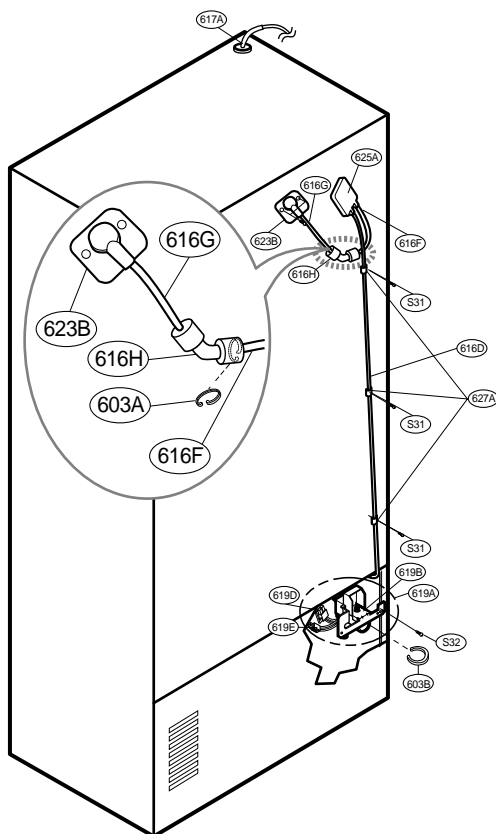

LOC No.	775**	Description
603A	4004JA3002A	Clip
603D	4930JA3091A	Holder,Bracket
616D	5210JA3005L	Tube,Plastic
616F	5210JA3004U	Tube,Plastic
616G	5210JA3005W	Tube,Plastic
616H	4932JA3009A	Connector,Tube
617A	4970JA3004N	Spring
619A	5221JA2011J	Valve,Water
619B	5220JB2008A	Valve,Water
619D	6877JB3036K	Drawing,Assembly
619E	6877JB3036M	Drawing,Assembly
623B	5006JJ2009A	Cap,Cover
625A	3550JA2184B	Cover,Tube
627A	4930JA3054A	Holder,PipeS31
S31	4J00415D	Screw,Customized
S32	4000W4A003A	Screw,Customized

CAUTION: Use the part number to order part, not the location number.



CASE PARTS

CAUTION: Use the part number to order part, not the position number.

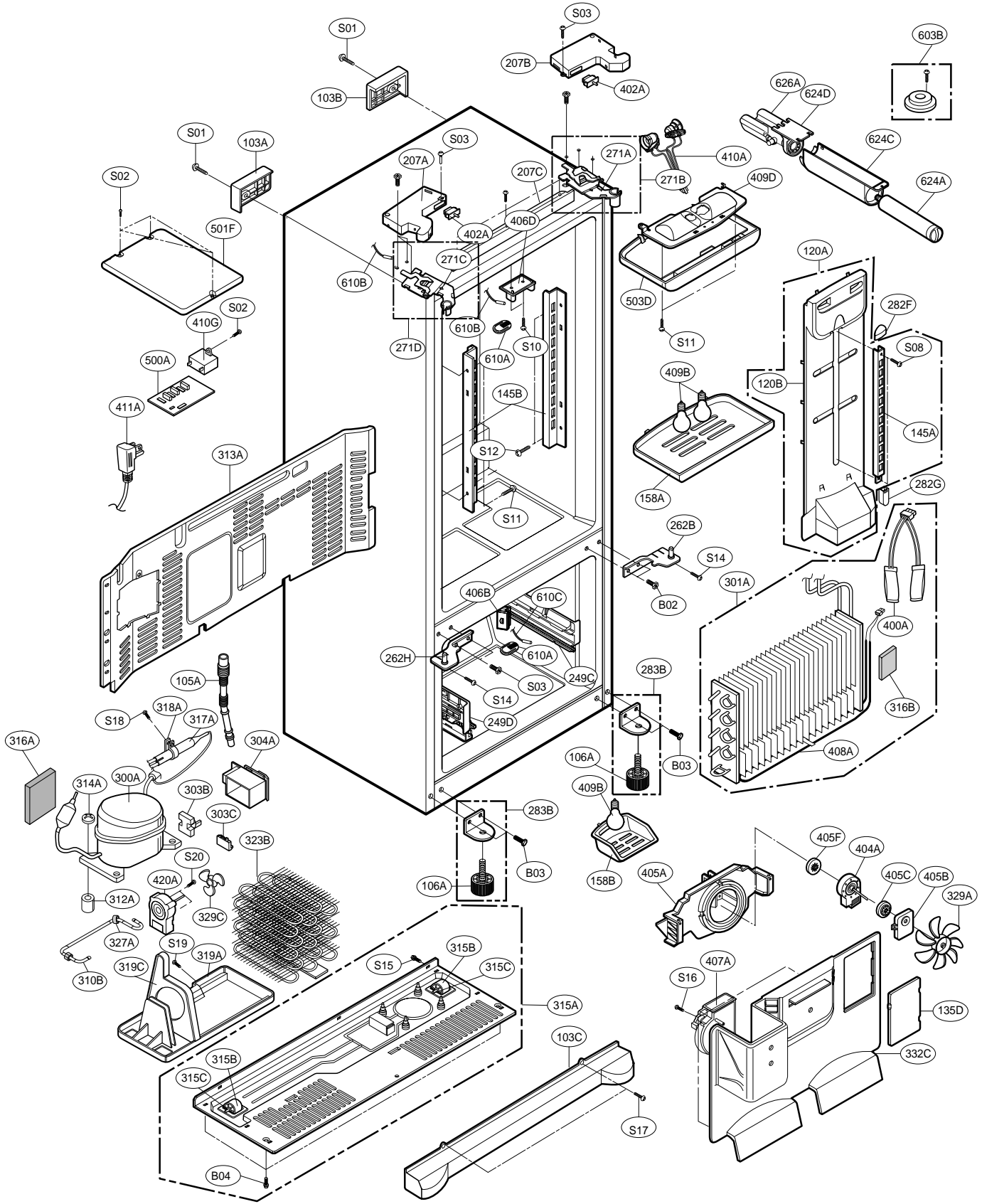

CASE PARTS

LOC No.	775*3(ST)	775*2(SW)	775*9(WB)	775*4(BI)	Description
103A	3650JA2061X	3650JA2061B	3650JA2113N	3650JA2061V	Handle,Rear
103B	3650JA2061W	3650JA2061A	3650JA2113P	3650JA2061U	Handle,Rear
103C	3550JJ0008L	3550JJ0008A	3550JJ0008C	3550JJ0008B	Cover,Lower
105A	5251JA3003B	5251JA3003B	5251JA3003B	5251JA3003B	Tube Assembly,Drain
106A	4779JJ2001B	4779JJ2001B	4779JJ2001B	4779JJ2001B	Leg Assembly,Adjust
120B	5208JA1156A	5208JA1156A	5208JA1156A	5208JA1156A	Duct,Multi
135D	3551JJ2028A	3551JJ2028A	3551JJ2028A	3551JJ2028A	Cover Assembly,Grille Fan
145A	4930JA2080C	4930JA2080C	4930JA2080C	4930JA2080C	Holder,Shelf
145B	4930JA2081C	4930JA2081C	4930JA2081C	4930JA2081C	Holder,Shelf
158A	3550JJ1070B	3550JJ1070B	3550JJ1070B	3550JJ1070B	Cover,Lamp
158B	3550JA1386B	3550JA1386B	3550JA1386B	3550JA1386B	Cover,Lamp
207A	3550JJ1097Q	3550JJ1097A	3550JJ1097E	3550JJ1097C	Cover,Hinge
207B	3550JJ1097R	3550JJ1097B	3550JJz097F	3550JJ1097D	Cover,Hinge
207C	3806JA2146E	3806JA2146A	3806JA2146C	3806JA2146D	Decor Assembly,Case
249C	4930JA1066A	4930JA1066A	4930JA1066A	4930JA1066A	Holder,Rail
249D	4930JA1066B	4930JA1066B	4930JA1066B	4930JA1066B	Holder,Rail
262B	4775JJ2017P	4775JJ2017B	4775JJ2017F	4775JJ2017K	Hinge Assembly,Center
262H	4775JJ2017R	4775JJ2017D	4775JJ2017H	4775JJ2017M	Hinge Assembly,Center
271A	4775JJ2014B	4775JJ2014B	4775JJ2014B	4775JJ2014B	Hinge Assembly,Upper
271B	4510JA3004A	4510JA3004A	4510JA3004A	4510JA3004A	Lever,Hinge
271C	4775JJ2014A	4775JJ2014A	4775JJ2014A	4775JJ2014A	Hinge Assembly,Upper
282F	3806JL1037A	3806JL1037A	3806JL1037A	3806JL1037A	Decor,Duct
282G	5006JA3111A	5006JA3111A	5006JA3111A	5006JA3111A	Cap,Duct
283B	4774JJ3002A	4774JJ3002A	4774JJ3002A	4774JJ3002A	Hinge,Lower
300A	TCA31748001	TCA31748001	TCA3174800 1	TCA31748001	Compressor,Set Assembly
301A	5421JJ1003B	5421JJ1003B	5421JJ1003B	5421JJ1003B	Evaporator Assembly
303A	EBG31940225	EBG31940225	EBG31940225	EBG31940225	Thermistor Assembly,PTC
303B	6748C-0004D	6748C-0004D	6748C-0004D	6748C-0004D	Thermistor Assembly,PTC
303C	6750C-0004R	6750C-0004R	6750C-0004R	6750C-0004R	Overload Protect
303D	6877JB2051F	6877JB2051F	6877JB205 1 F	6877JB2051F	Drawing,Assembly
304A	3550JA2042C	3550JA2042C	3550JA2042C	3550JA2042C	Cover,PTC
310B	4J00977N	4J00977N	4J00977N	4J00977N	Pipe,Compressor Sealing
312A	5040JA3071A	5040JA3071A	5040JA3071A	5040JA3071A	Damper,Compressor
313A	3551JJ2018A	3551JJ2018A	3551JJ2018A	3551JJ2018A	Cover Assembly,Machinery(Rear)
314A	4620JA3015A	4620JA3015A	4620JA3015A	4620JA3015A	Stopper,Compressor
315A	3103JJ1001H	3103JJ1001H	3103JJ1001H	3103JJ1001H	Base Assembly,Compressor
315B	4580JJ3001A	4580JJ3001A	4580JJ3001A	4580JJ3001A	Roller
315C	1PZZJA3013B	1 PZZJA3013B	1PZZJA3013B	1PZZJA3013B	Pin,Common
316A	5072JA3003F	5072JA3003F	5072JA3003F	5072JA3003F	Damper,Noise
316B	5072JA3003B	5072JA3003B	5072JA3003B	5072JA3003B	Damper,Noise
317A	5851JA2008U	5851JA2008U	5851JA2008U	5851JA2008U	Drier Assembly
318A	4930JA3034A	4930JA3034A	4930JA3034A	4930JA3034A	Holder,Drier
319A	3390JA0040A	3390JA0040A	3390JA0040A	3390JA0040A	Tray,Drip
319C	4974JJ1036A	4974JJ1036A	4974JJ1036A	4974JJ1036A	Guide,Fan
323B	5403JJ1004B	5403JJ1004B	5403JJ1004B	5403JJ1004B	Condenser Assembly,Wire
327A	4J03020A	4J03020A	4J03020A	4J03020A	Damper,Pipe
329A	5901JA1021A	5901JA1021A	5901JA1021A	5901JA1021A	Fan Assembly
329C	5901JA1013A	5901JA1013A	5901JA1013A	5901JA1013A	Fan Assembly
332C	AEB34270101	AEB34270101	AEB34270101	AEB34270101	Grille Assembly,Fan
400A	6615JB2005H	6615JB2005H	6615JB2005H	6615JB2005H	Controller Assembly
402A	6600JB3007B	6600JB3007A	6600JB3007E	6600JB3007A	Switch,Push Button
402C	6600JB3001E	6600JB3001E	6600JB3001E	6600JB3001E	Switch,Micro
404A	4681JK1004E	4681JK1004E	4681JK1004E	4681JK1004E	Motor,DC
405B	4810JJ2005A	4810JJ2005A	4810JJ2005A48	10JJ2005A	Bracket,Motor
405C	5040JA2009B	5040JA2009B	5040JA2009B	5040JA2009B	Damper,.,Motor Support
405F	5040JA2004B	5040JA2004B	5040JA2004B	5040JA2004B	Damper,Motor Support
406B	6600JB1010A	6600JB1010A	6600JB1010A	6600JB1010A	Switch,Push B utton

CAUTION: Use the part number to order part, not the position number.

CASE PARTS

LOC No.	775*3(ST)	775*2(SW)	775*9(WB)	775*4(BI)	Description
406D	4931JA3006A	4931JA3006A	4931JA3006A	4931JA3006A	Holder Assembly, Gasket
407A	5209JA1044A	5209JA1044A	5209JA1044A	5209JA1044A	Duet Assembly, Connector
407B	4810JJ0003A	4810JJ0003A	4810JJ0003A	4810JJ0003A	Bracket, Motor
408A	5300JK1005D	5300JK1005D	5300JK1005D	5300JK1005D	Heater, Sheath
409B	6912JB2004K	6912JB2004K	6912JB2004K	6912JB2004K	LAMP, [INCANDESCENT]
409D	3034JA1009A	3034JA1009A	3034JA1009A	3034JA1009A	Reflector, Lamp
410A	6621JK2003B 0CZZJB2014B	6621JK2003B 0CZZJB2014B	6621JK2003B 0CZZJB2014B	6621JK2003B 0CZZJB2014B	Drawing, Assembly
410G	(*)0CZZJB2012H (*)0CZZJB2012K	(*)0CZZJB2012H (*)0CZZJB2012K	(*)0CZZJB2012H (*)0CZZJB2012K	(*)0CZZJB2012H (*)0CZZJB2012K	Capacitor, Film, Box
410H	*J513-00012P	*J513-00012P	*J513-00012P	*J513-00012P	Capacitor, Film, CYL
410J	*3111JB1017J	*3111JB1017J	*3111JB1017J	*3111JB1017J	Case Assembly, PCB
411A	6411JB1042L	6411JB1042L	6411JB1042L	6411JB1042L	POWER CORD ASSEMBLY
420A	4681JB1029D	4681JB1029D	4681JB1029D	4681JB1029D	Motor, Unclassified
500A	EBR34917104	EBR34917104	EBR34917104	EBR34917104	PCB Assembly, Main
501F	3551JA2144C	3551JA2144C	3551JA2144C	3551JA2144C	Cover Assembly, PCB
503D	3110JJ1014A	3110JJ1014A	3110JJ1014A	3110JJ1014A	Case, Lamp
603B	4931JA3005B	4931JA3005B	4931JA3005B	4931JA3005B	Holder Assembly, Bracket
610A	3550JA2247A	3550JA2247A	3550JA2247A	3550JA2247A	Cover, Sensor
610B	6500JB2001B	6500JB2001B	6500JB2001B	6500JB2001B	SENSOR
610C	6500JB2002B	6500JB2002B	6500JB2002B	6500JB2002B	SENSOR
624A	5231JA2006A	5231JA2006A	5231JA2006A	5231JA2006A	Filter Assembly, Water
624C	3550JD1128B	3550JD1128B	3550JD1128B	3550JD1128B	Cover, Filter
624D	5230JA2003A	5230JA2003A	5230JA2003A	5230JA2003A	Filter, Head
626A	3550JA2279A	3550JA2279A	3550JA2279A	3550JA2279A	Cover, Filter
B02	1STZJA3004Q	1STZJA3004Q	1STZJA3004D	1STZJA3004Q	Screw, Customzied
B03	1STZJA3004F	1STZJA3004F	1STZJA3004F	1STZJA3004F	Screw, Customzied
B04	1BZZJA2002A	1BZZJA2002A	1BZZJA2002A	1BZZJA2002A	Bolt, Common
S01	4J00415D	4J00415D	4J00415D	4J00415D	Screw, Customzied
S02	4J00415D	4J00415D	4J00415D	4J00415D	Screw, Customzied
S03	4J01424B	4J01424B	4J01424B	4J01424B	Screw, Customzied
S08	1SZZJJ3005E	1SZZJJ3005E	1SZZJJ3005E	1SZZJJ3005E	Screw, Customzied
S09	4J00415D	4J00415D	4J00415D	4J00415D	Screw, Customzied
S10	1SBZJA3004L	1SBZJA3004L	1SBZJA3004L	1SBZJA3004L	Screw, Customzied
S11	3J05696W	3J05696W	3J05696W	3J05696W	Screw, Customzied
S13	1SZZJJ3005E	1SZZJJ3005E	1SZZJJ3005E	1SZZJJ3005E	Screw, Customzied
S14	1SZZJJ3010D	1SZZJJ3010D	1SZZJJ3010B	1SZZJJ3010D	Screw, Customzied
S15	4000W4A003A	4000W4A003A	4000W4A003A	4000W4A003A	Screw, Customzied
S16	3J05696W	3J05696W	3J05696W	3J05696W	Screw, Customzied
S17	1SZZJA3005H	1SZZJA3005H	1SZZJA3005H	1SZZJA3005H	Screw, Customzied
S18	4J00415D	4J00415D	4J00415D	4J00415D	Screw, Customzied
S19	4J00415D	4J00415D	4J00415D	4J00415D	Screw, Customzied
S20	1SZZJA3016A	1SZZJA3016A	1SZZJA3016A	1SZZJA3016A	Screw, Customzied

CAUTION: Use the part number to order part, not the position number.

FREEZER PARTS

CAUTION: Use the part number to order part, not the position number.

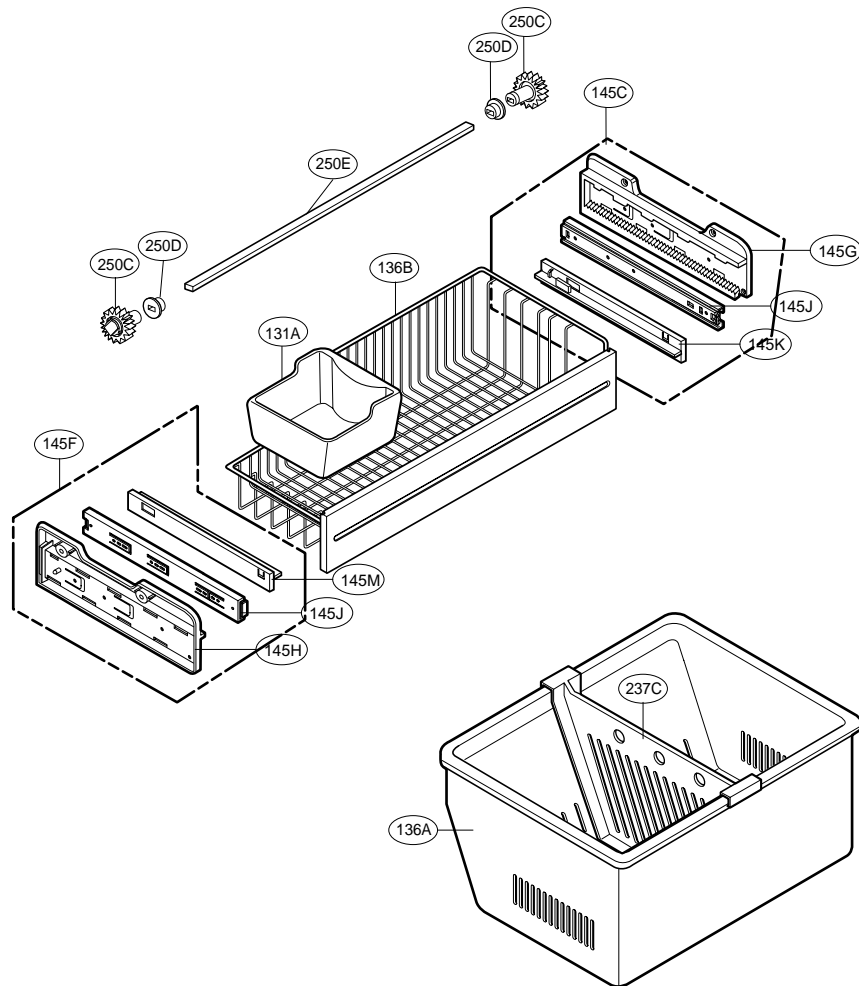

LOC No.	775*3(ST)	775*2(SW)	775*9(WB)	775*4(BI)	Description
131A	5074JA2004A	5074JA2004A	5074JA2004A	5074JA2004A	Bucket,Ice
136A	3390JJ1072A	3390JJ1072A	3390JJ1072A	3390JJ1072A	Tray,Drawer
136B	3391JA2054D	3391JA2054D	3391JA2054D	3391JA2054D	Tray Assembly,Drawer
145C	4975JA1040F	4975JA1040F	4975JA1040F	4975JA1040F	Guide Assembly,Rail
145F	4975JA1040E	4975JA1040E	4975JA1040E	4975JA1040E	Guide Assembly,Rail
237C	4974JJ1031A	4974JJ1031A	4974JJ1031A	4974JJ1031A	Guide,Drawer
250C	4470JA2008A	4470JA2008A	4470JA2008A	4470JA2008A	Gear,Ice
250D	5006JA2069A	5006JA2069A	5006JA2069A	5006JA2069A	Cap,Cover
250E	MAK36519001	MAK36519001	MAK36519001	MAK36519001	Bar

CAUTION: Use the part number to order part, not the position number.

REFRIGERATOR PARTS

CAUTION: Use the part number to order part, not the position number.

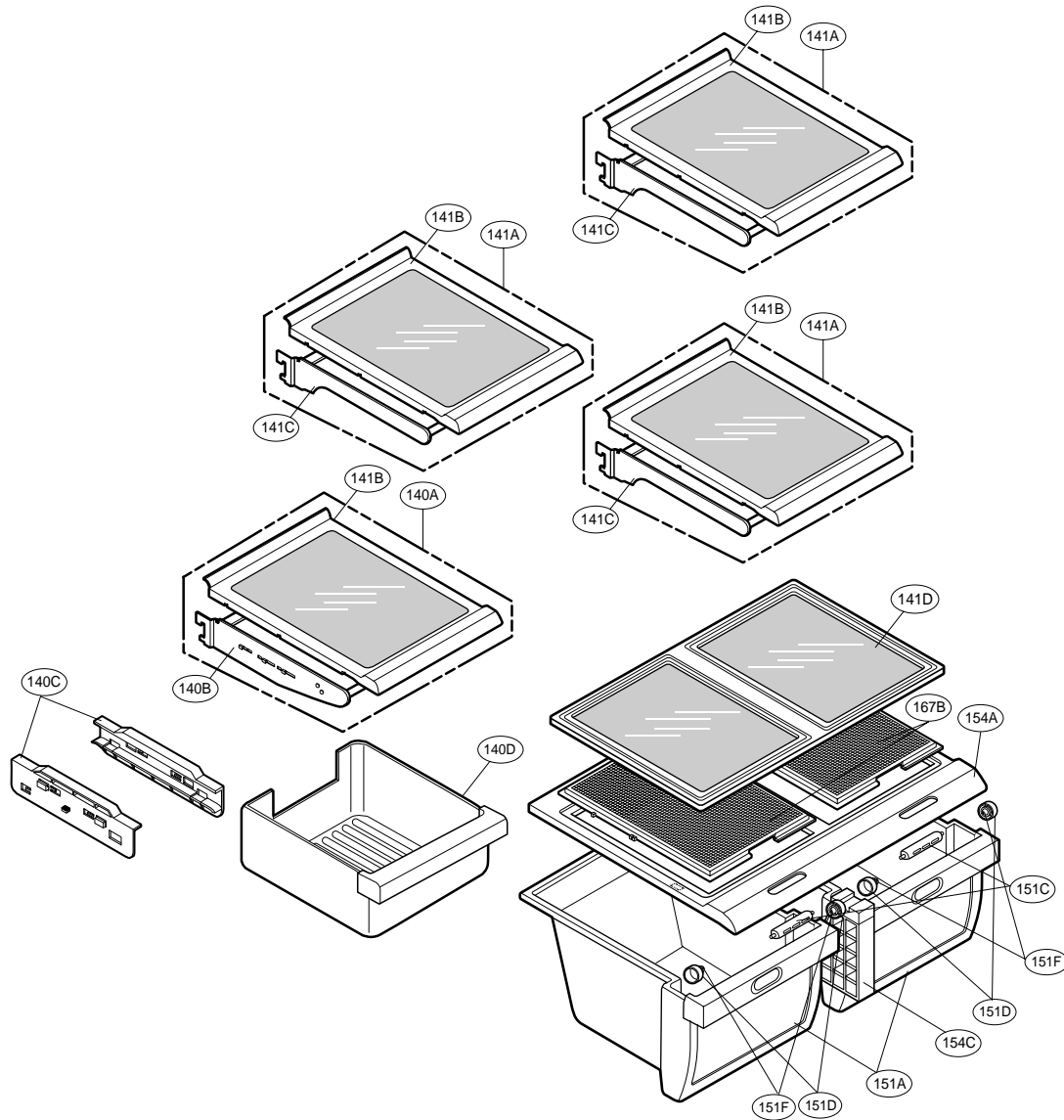

LOC No.	775*3(ST)	775*2(SW)	775*9(WB)	775*4(BI)	Description
140A	5027JJ2014J	5027JJ2014J	5027JJ2014J	5027JJ2014J	Shelf Assembly,Refrigerator
140B	5027JJ2012D	5027JJ2012D	5027JJ2012D	5027JJ2012D	Shelf Assembly,Net
140C	4975JA2028A	4975JA2028A	4975JA2028A	4975JA2028A	Guide Assembly,Rail
140D	3391JA2055C	3391JA2055C	3391JA2055C	3391JA2055C	Tray Assembly,Meat
141A	5027JJ2014D	5027JJ2014D	5027JJ2014D	5027JJ2014D	Shelf Assembly,Refrigerator
141B	5026JJ1050B	5026JJ1050B	5026JJ1050B	5026JJ1050B	Shelf,Refrigerator
141C	5027JJ2012F	5027JJ2012F	5027JJ2012F	5027JJ2012F	Shelf Assembly,Net
141D	4890JL1012A	4890JL1012A	4890JL1012A	4890JL1012A	Cover,Glass
151A	3391JJ2014C	3391JJ2014C	3391JJ2014C	3391JJ2014C	Tray Assembly,Vegetable
151C	4940JA2026C	4940JA2026C	4940JA2026C	4940JA2026C	Knob,Shutter
151D	4850JA3042A	4850JA3042A	4850JA3042A	4850JA3042A	Roller
151F	1SZZJA3011B	1SZZJA3011B	1SZZJA3011B	1SZZJA3011B	Screw, Customized
154A	3550JD1129A	3550JD1129A	3550JD1129A	3550JD1129A	Cover,TV
154C	4980JA2092A	4980JA2092A	4980JA2092A	4980JA2092A	Supporter. Cover TV
167B	3550JJ1069A	3550JJ1069A	3550JJ1069A	3550JJ1069A	Cover,Magic Room

CAUTION: Use the part number to order part, not the position number.

DOOR PARTS

CAUTION: Use the part number to order part, not the position number.

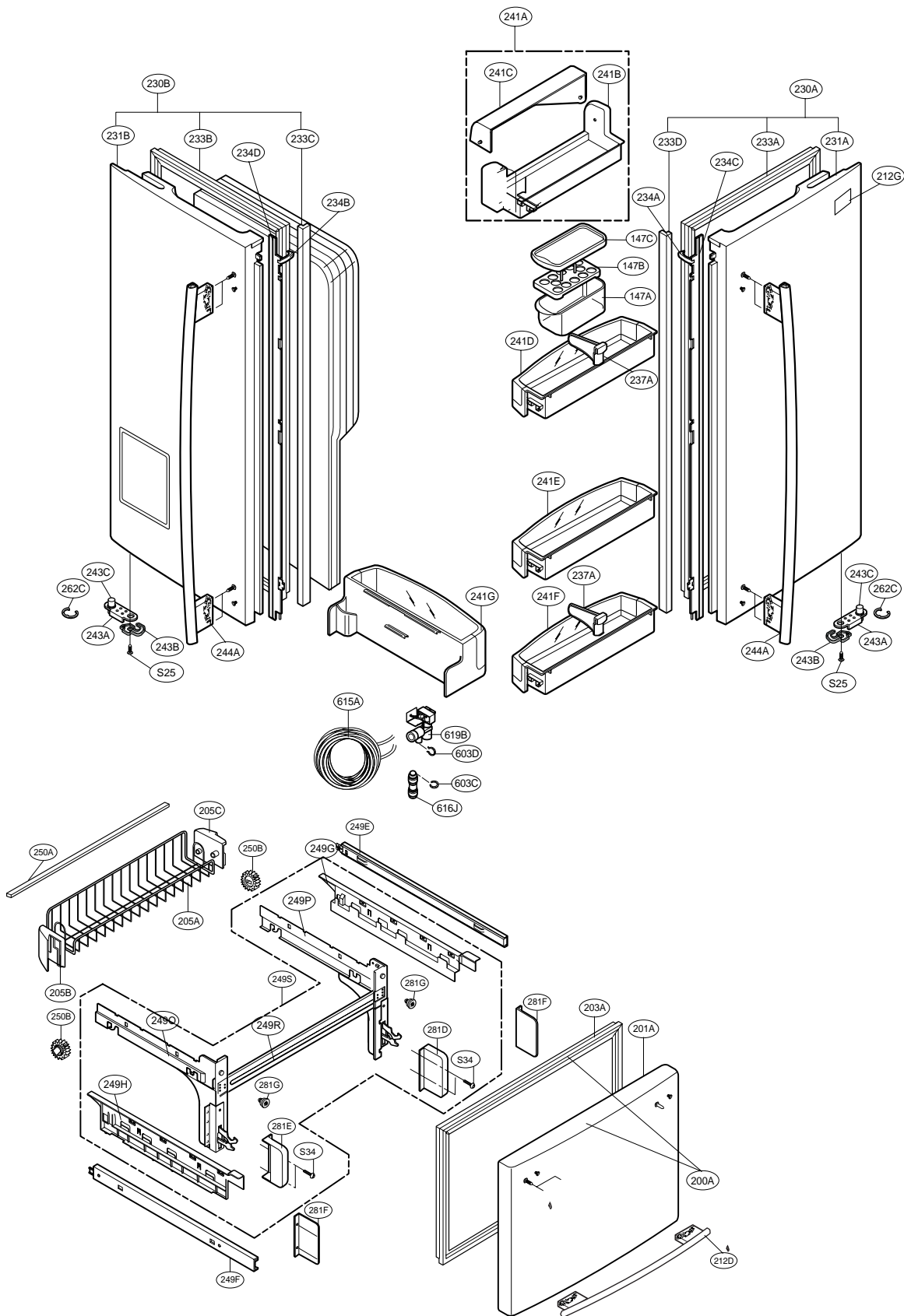

▲ Only for the service



DOOR PARTS

LOCNo.	775*3(ST)	775*2(SW)	775*9(WB)	775*4(BI)	Description
146A	J469-00030A	J469-00030A	J469-00030A	J469-00030A	Rack (7757* only)
147A	5074JJ1016A	5074JJ1016A	5074JJ1016A	5074JJ1016A	Bucket,Dairy
147B	3390JJ1082A	3390JJ1082A	3390JJ1082A	3390JJ1082A	Tray,Egg
147C	3550JJ1084A	3550JJ1084A	3550JJ1084A	3550JJ1084A	Cover,Bucket
200A	3581JA8820K	3581JA8820N	3581JA8820L	3581JA8820M	Door Assembly,Freezer
201A	5433JA8558K	5433JA8558N	5433JA8558L	5433JA8558M	Door Foam Assembly,Freezer
203A	4987JA2008E	4987JA2008E	4987JA2008J	4987JA2008E	Gasket Assembly,Door
205A	5004JJ1061B	5004JJ1061B	5004JJ1061B	5004JJ1061B	Basket,Door
205B	5004JA2017A	5004JA2017A	5004JA2017A	5004JA2017A	Basket,Tilt
205C	5004JA2017B	5004JA2017B	5004JA2017B	5004JA2017B	Basket,Tilt
212D	3651JA2279A	3651JA2279B	3651JA2279D	3651JA2279C	Handle Assembly,Freezer
212G	3846JD2003A	3846JD2003A	3846JD2003A	3846JD2003A	Name Plate
230A	3581JA8814E	3581JA8814H	3581JA8814F	3581JA8814G	Door Assembly,Refrigerator(Right)
231A	5433JA8560E	5433JA8560H	5433JA8560F	5433JA8560G	Door Foam Assembly,Refrigerator
230B	3581JA8815E	3581JA8815H	3581JA8815F	3581JA8815G	Door Assembly,Refrigerator(Left)
231B	5433JA8561E	5433JA8561H	5433JA8561F	5433JA8561G	Door Foam Assembly,Refrigerator
233A	4987JJ2002A	4987JJ2002A	4987JJ2002C	4987JJ2002A	Gasket Assembly,Door
233B	4987JJ2002B	4987JJ2002B	4987JJ2002D	4987JJ2002B	Gasket Assembly,Door
233C	3551JJ2030B	3551JJ2030B	3551JJ2030B	3551JJ2030B	Cover Assembly,Front
233D	3551JJ2030A	3551JJ2030A	3551JJ2030A	3551JJ2030A	Cover Assembly,Front
234A	4430JJ2004A	4430JJ2004A	4430JJ2004A	4430JJ2004A	Cam, Shaft
234C	4931JJ2002A	4931JJ2002A	4931JJ2002A	4931JJ2002A	Holder Assembly, Gasket
234D	4931JJ2002B	4931JJ2002B	4931JJ2002B	4931JJ2002B	Holder Assembly, Gasket
234B	4430JJ2004B	4430JJ2004B	4430JJ2004B	4430JJ2004B	Cam, Shaft
237A	4974JA2055A	4974JA2055A	4974JA2055A	4974JA2055A	Guide,Pitcher
241A	5005JJ2015B	5005JJ2015B	5005JJ2015B	5005JJ2015B	Basket Assembly,Door
241B	5004JJ1057A	5004JJ1057A	5004JJ1057A	5004JJ1057A	Basket,Door
241C	5004JL1006B	5004JL1006B	5004JL1006B	5004JL1006B	Basket,Window
241D	5005JJ2014A	5005JJ2014A	5005JJ2014A	5005JJ2014A	Basket Assembly,Door
241E	5005JJ2014A	5005JJ2014A	5005JJ2014A	5005JJ2014A	Basket Assembly,Door
241F	5005JJ2014H	5005JJ2014H	5005JJ2014H	5005JJ2014H	Basket Assembly,Door
241G	5005JA2071B	5005JA2071B	5005JA2071B	5005JA2071B	Basket Assembly,Door
243A	4620JJ3006D	4620JJ3006A	4620JJ3006C	4620JJ3006B	Stopper,Door
243B	4620JJ2009A	4620JJ2009A	4620JJ2009A	4620JJ2009A	Stopper,Door
243C	J326-00012A	J326-00012A	J326-00012A	J326-00012A	Bush
244A	3651JA2278A	3651JA2278B	3651JA2278D	3651JA2278C	Handle Assembly,Refrigerator
249A	5098JJ2002T	5098JJ2002T	5098JJ2002T	5098JJ2002T	Connector Assembly
249B	5098JJ2002S	5098JJ2002S	5098JJ2002S	5098JJ2002S	Connector Assembly
249E	5218JA1010E	5218JA1010E	5218JA1010E	5218JA1010E	Rail,Slide
249F	5218JA1010F	5218JA1010F	5218JA1010F	5218JA1010F	Rail,Slide
249G	5098JA2001H	5098JA2001H	5098JA2001H	5098JA2001H	Connector Assembly
249H	5098JA2001G	5098JA2001G	5098JA2001G	5098JA2001G	Connector Assembly
262C	4350JA3005B	4350JA3005B	4350JA3005B	4350JA3005B	Ring
281C	4811JJ2015A	4811JJ2015A	4811JJ2015A	4811JJ2015A	Bracket Assembly,Door
281D	3550JA2267B	3550JA2267B	3550JA2267B	3550JA2267B	Cover,Hinge
281E	3550JA2267A	3550JA2267A	3550JA2267A	3550JA2267A	Cover,Hinge
281F	3550JA2264A	3550JA2264A	3550JA2264A	3550JA2264A	Cover,Hinge
281G	5040JA3075A	5040JA3075A	5040JA3075A	5040JA3075A	Damper
603C	4004JA3002A	4004JA3002A	4004JA3002A	4004JA3002A	Clip
603D	4930JA3091A	4930JA3091A	4930JA3091A	4930JA3091A	Holder, Bracket
615A	4838JA2003A	4838JA2003A	4838JA2003A	4838JA2003A	Tank,Water
616J	4932JA3009A	4932JA3009A	4932JA3009A	4932JA3009A	Connector, Tube
619B	5220JB2008A	5220JB2008A	5220JB2008A	5220JB2008A	Valve, Water
S25	1SZZJA3011D	1SZZJA3011D	1SZZJA3011D	1SZZJA3011D	Screw,Customzied
S34	FAB30025701	FAB30025701	FAB30025701	FAB30025701	Screw,Customzied

CAUTION: Use the part number to order part, not the position number.

DISPENSER PARTS

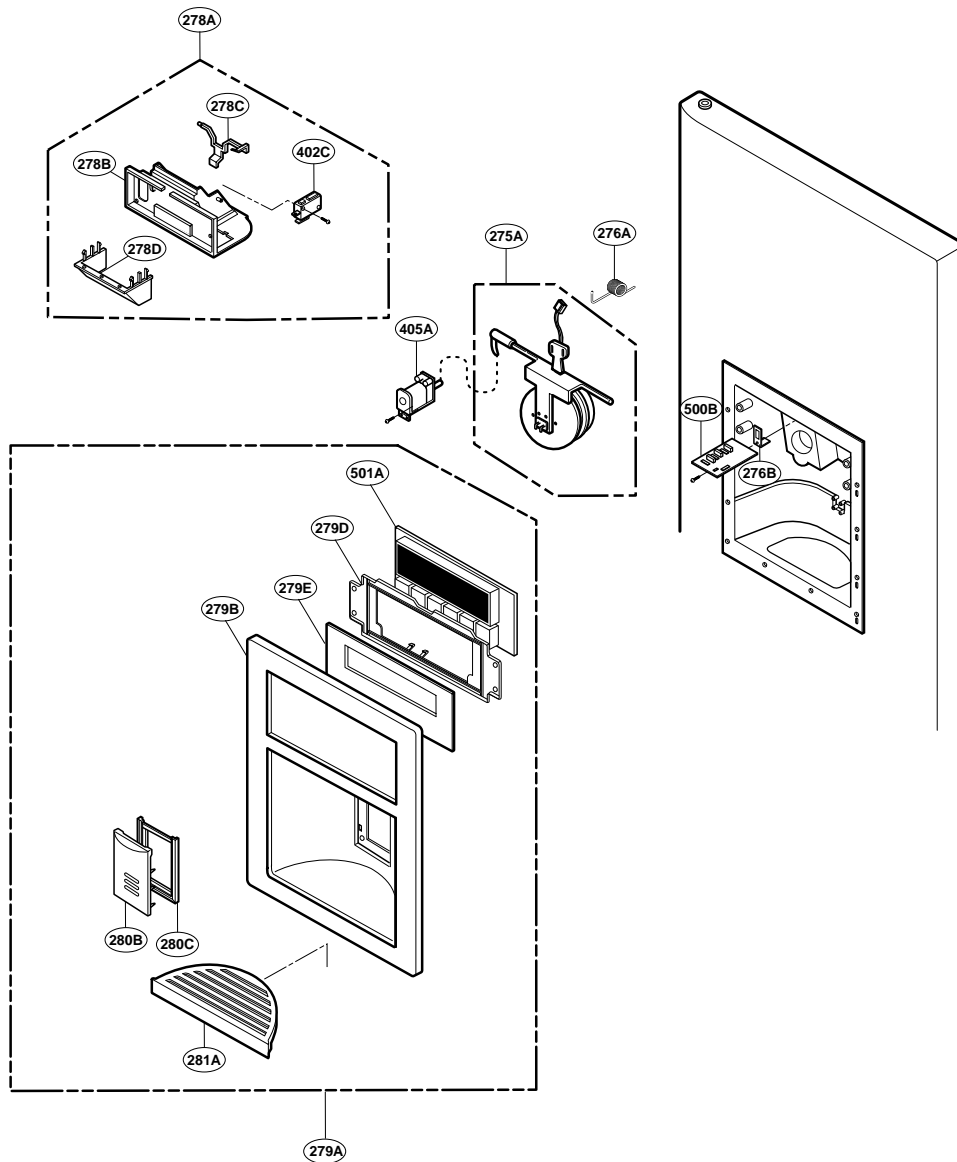

LOCNo.	775*3(ST)	775*2(SW)	775*9(WB)	775*4(BI)	Description
275A	5007JA3006R	5007JA3006R	5007JA3006R	5007JA3006R	Cap Assembly, Duct
276A	4970JA3025B	4970JA3025B	4970JA3025B	4970JA3025B	Spring, Lever
276B	4930JA3043A	4930JA3043A	4930JA3043A	4930JA3043A	Holder, Lever
278A	3017JA2008B	3017JA2008A	3017JA2008C	3017JA2008D	Funnel Assembly
278B	3210JA1072B	3210JA1072A	3210JA1072C	3210JA1072D	Frame, Funnel
278C	4510JA2027A	4510JA2027A	4510JA2027A	4510JA2027A	Lever, Ice Maker
279A	3551JA1132M	3551JA1132L	3551JA1132N	3551JA1132P	Cover Assembly, Dispenser
279B	3550JA1468B	3550JA1468A	3550JA1468C	3550JA1468D	Cover, Dispenser
279C	3806JA1189A				Decor, Cover Display
279D	3550JA2302A	3550JA2302A	3550JA2302A	3550JA2302A	Cover, PCB
279E	4890JD1112A	4890JD1112A	4890JD1112A	4890JD1112A	Decor, Glass Door
280B	4930JA2074B	4930JA2074B	4930JA2074B	4930JA2074B	Holder, Button
280C	5020JA2040E	5020JA2040F	5020JA2040K	5020JA2040D	Button, Lever
281A	3806JA2150A	3806JA2118A	3806JA2118C	3806JA2118D	Decor, Drain
402C	6600JB3001E	6600JB3001E	6600JB3001E	6600JB3001E	SWITCH, [MICRO]
405A	6421JB2002D	6421JB2002D	6421JB2002D	6421JB2002D	SOLENOID ASSEMBLY
500B	6871JB2061B	6871JB2061B	6871JB2061B	6871JB2061B	PCB Assembly, Sub
501A	6871JB1451A	6871JB1451A	6871JB1451A	6871JB1451A	PCB Assembly, Display

ICE MAKER & ICE BANK PARTS

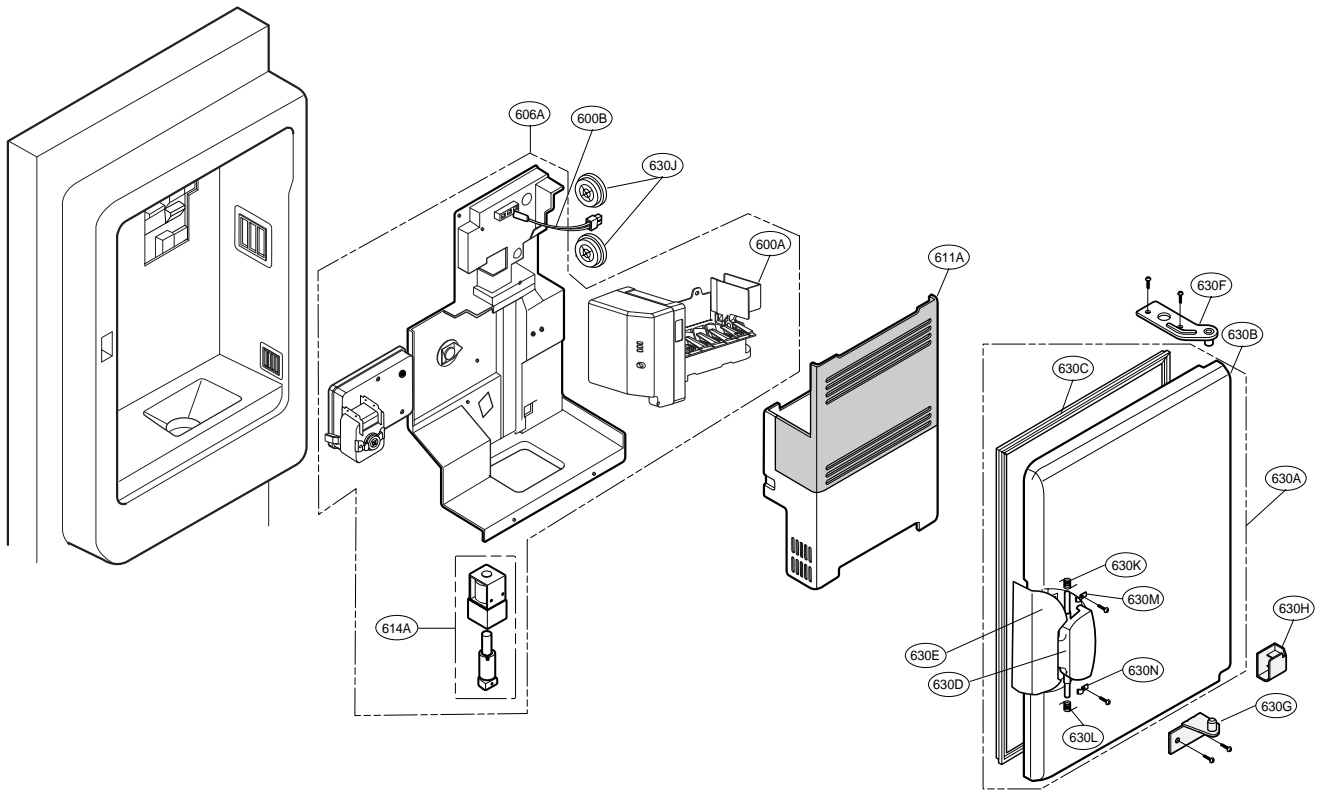

LOCNo.	775**	Description
600A	5989JB0001A	Ice Maker Assembly, Kit
606A	4681JA1006D	Motor, AC
610A	5075JA1044B	Bucket Assembly, Ice
630A	3581JA1182B	Door Assembly, Freeze Room
630B	5433JA2071B	Door Foam Assembly, Home Bar
630C	4987JA2012A	Gasket Assembly, Door
630D	3650HA2160A	Handle, Home Bar
630E	3806JA2160A	Decor, Handle
630F	4775JA2101A	Hinge Assembly, Upper
630G	4775JA2102A	Hinge Assembly, Lower
630H	3550JA3188A	Cover, Home Bar
630J	4987JA3025B	Gasket Assembly, Door
630K	4970JA3044A	Spring
630L	4970JA3045A	Spring
630M	4860JA3010A	Clamp
630N	4860JA3010B	Clamp



*'You Can Count on me . . .
to Work Safely.'*