

Please read and save these instructions. Read carefully before attempting to assemble, install, operate or maintain the product described. Protect yourself and others by observing all safety information. Failure to comply with instructions could result in personal injury and/or property damage! Retain instructions for future reference.

Dayton® 17" Floor Model Drill Press

Description

Dayton Drill Press features a heavy cast iron base, column collar, work table and head. Work table height is adjustable using rack and pinion. Table can be tilted 45° both right and left, and rotates 360° on a vertical axis. Work table surface is precision ground which features T-slots for secure, accurate mounting of work-piece and a coolant trough. Digital readout displays spindle depth and RPM. Other features of the Dayton drill press are an enclosed ball bearing quill assembly, quick belt change and tension mechanism, positive quick-adjust feed depth stop and a 1 HP, 1725 RPM motor. A chuck and chuck arbor are included.

Dayton drill press are ideal for use in home shops, maintenance shops and light industrial applications. Spindle speeds are adjustable for drilling steel, cast iron, aluminum, wood and plastic.

Unpacking

Refer to Figure 1.

▲WARNING Be careful not to touch overhead power lines, piping, lighting, etc., if lifting equipment is used. Drill press weighs up to 216 lbs. Proper tools, equipment and qualified personnel should be employed in all phases of unpacking and installation.

Crates should be handled with care to avoid damage from dropping, bumping, etc. Store and unpack crates with correct side up. After uncrating drill press, inspect carefully for any damage that may have occurred during transit. Check for loose, missing or damaged parts. If any damage or loss has occurred, claim must be filed with carrier immediately. Check for completeness. Immediately report missing parts to dealer.

Check for shipping damage. If damage has occurred, a claim must be filed with the carrier immediately. Check for completeness. Immediately report missing parts to dealer.

The drill press is shipped unassembled. Locate and identify the following assemblies and loose parts:

- A Head Assembly
- B Table
- C Base
- D Column Assembly

- E Feed Handle Knob
- F Feed Handle
- G Table Handle
- H Table Handle Knob
- I Center Pulley Assembly

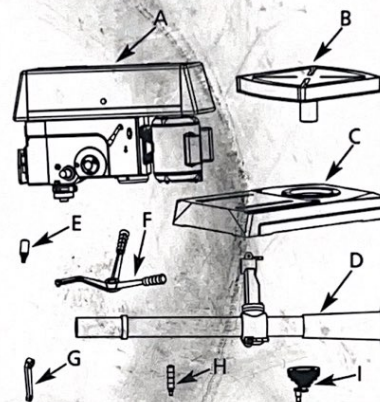

Figure 1 - Unpacking

Not Shown: Drill Chuck with Key, Arbor, Drill Drift, M8 x 24 Key, Plate, M6 x 16 Tap Screw, five M10 x 40 Socket Head Bolts, 3, 5 and 8mm Hex Wrenches, two M8 x 125 Hex Head Bolts, two M8 Lock Washers, four M8 Flat Washers, and two M8 Hex Nuts.

IMPORTANT: Many unpainted steel surfaces, such as column and table top, have been coated with a protectant. To ensure proper fit and operation, remove coating. Coating is easily removed with

mild solvents, such as mineral spirits, and a soft cloth. Avoid getting solution on paint or any of the rubber or plastic parts. Solvents may deteriorate these finishes. Use soap and water on paint, plastic or rubber components. After cleaning, cover all exposed surfaces with a light coating of oil. Paste wax is recommended for table top.

▲WARNING Never use highly volatile solvents. Non-flammable solvents are recommended to avoid possible fire hazard.

Specifications

Chuck size	1/25-5/8, JT3
Spindle taper	MT2
Spindle travel	5"
Quill diameter	2.047"
Quill collar diameter	2.60" (66mm)
Column diameter	3.15"
Speeds	16
RPM	138-3476
Swing	17"
Table size	11½ x 13"
Table working surface	11½ x 13"
T-slots (diagonal)	4 x 14mm
Base size	12¾ x 19¾"
Base working surface	10¾ x 11"
Drilling capacity (cast iron)	5/8"
Distance, spindle to table	1½-25"
Distance, spindle to base	45"
Overall height	65¼"
Weight	206 lbs
Shipping weight	216 lbs
Motor	1 HP, 120/240 V, 1725 RPM 10.2/5.1 Amps, 60 HZ

General Safety Information

▲WARNING For your own safety, read all of the instructions and precautions before operating tool.



Dayton® 17" Floor Model Drill Press

General Safety Information (Continued)

PROPOSITION 65 WARNING: Some dust created by using power tools contain chemicals known to the state of California to cause cancer, birth defects or other reproductive harm.

Some examples of these chemicals are:

1. Lead from lead-based paints.
2. Crystalline silica from bricks and cement and other masonry products.
3. Arsenic and chromium from chemically treated lumber.

▲ WARNING *Your risk from these exposures vary, depending on how often you do this type of work. To reduce your exposure to these chemicals: work in a well ventilated area and work with approved safety equipment. Always wear OSHA/NIOSH approved, properly fitting face mask or respirator when using such tools.*

▲ CAUTION *Always follow proper operating procedures as defined in this manual even if you are familiar with use of this or similar tools. Remember that being careless for even a fraction of a second can result in severe personal injury.*

BE PREPARED FOR JOB

1. Wear proper apparel. Do not wear loose clothing, gloves, neckties, rings, bracelets or other jewelry which may get caught in moving parts of machine.
2. Wear protective hair covering to contain long hair.
3. Wear safety shoes with non-slip soles.
4. Wear safety glasses complying with United States ANSI Z87.1. Everyday glasses have only impact resistant lenses. They are **NOT** safety glasses.
5. Wear face mask or dust mask if operation is dusty.
6. Be alert and think clearly. Never operate power tools when tired, intoxicated or when taking medications that cause drowsiness.

PREPARE WORK AREA FOR JOB

1. Keep work area clean. Cluttered work areas invite accidents.
2. Do not use power tools in dangerous environments. Do not use power tools in damp or wet locations. Do not expose power tools to rain.
3. Work area should be properly lighted.
4. Proper electrical receptacle should be available for tool. Three-prong plug should be plugged directly into properly grounded, three-prong receptacle.
5. Extension cords should have a grounding prong and the three wires of the extension cord should be of the correct gauge.
6. Keep visitors at a safe distance from work area.
7. Keep children out of workplace. Make workshop childproof. Use padlocks, master switches or remove switch keys to prevent any unintentional use of power tools.

TOOL SHOULD BE MAINTAINED

1. Always unplug tool prior to inspection.
2. Consult manual for specific maintaining and adjusting procedures.
3. Keep tool lubricated and clean for safest operation.
4. Remove adjusting tools. Form habit of checking to see that adjusting tools are removed before switching machine on.
5. Keep all parts in working order. Check to determine that the parts will operate properly and perform their intended function.
6. Check for damaged parts. Check for alignment of moving parts, binding, breakage, and mounting or any other condition that may affect a tool's operation.
7. Any damaged parts should be properly repaired or replaced. Do not perform makeshift repairs. (Use parts list provided to order repair parts.)

KNOW HOW TO USE TOOL

1. Use right tool for job. Do not force tool or attachment to do a job for which it was not designed.
2. Disconnect tool when changing drill bit or cutter.
3. Avoid accidental start-up. Make sure that the tool is in the OFF position before plugging in.
4. Do not force a tool. It will work most efficiently at the rate for which it was designed.
5. Keep hands away from moving parts and cutting surfaces.
6. Never leave tool running unattended. Turn the power off and do not leave tool until it comes to a complete stop.
7. Do not overreach. Keep proper footing and balance.
8. Never stand on tool. Serious injury could occur if tool is tipped or if drill bit is unintentionally contacted.
9. Know your tool. Learn the tool's operation, application and specific limitations.
10. Use recommended accessories (refer to page 11). Use of improper accessories may cause risk of injury to persons.
11. Handle workpiece correctly. Protect hands from possible injury.

Model 5PHC3B

E
N
G
L
I
S
H

General Safety Information (Continued)

12. Turn machine off if it jams. Drill bit jams when it digs too deeply into workpiece. (Motor force keeps it stuck in the work.)
13. All work shall be secured using either clamps or a vise to the drill press table. It is unsafe to use your hands to hold any workpiece being drilled.
14. Feed work into a bit or cutter against the direction of rotation of bit or cutter.
15. Use recommended speed for drill accessory and workpiece material.
16. Keep guards in place and in proper working order. Do not operate the machine with guards removed.
17. Always be sure the machine is securely anchored to the floor or the workbench.
18. Make certain table locks and head locks are tightened before starting machine.

▲ CAUTION *Think safety! Safety is a combination of operator common sense and alertness at all times when tool is being used.*

Assembly

Refer to Figures 7 and 8.

▲ WARNING *Do not attempt to operate tool until it is completely assembled according to the instructions.*

MOUNT COLUMN ASSEMBLY TO BASE

Refer to Figure 7.

1. Place base (Ref. No. 1) on flat level surface.
2. Mount column assembly (Ref. No. 7) to base using five socket head bolts (Ref. No. 6).

MOUNT TABLE

Refer to Figure 7.

1. Attach crank handle (Ref. No. 22) to shaft on worm gear (Ref. No. 20), rotate worm gear to remove slack, and shoulder crank handle against table bracket. Secure handle with set screw (Ref. No. 21). Attach crank handle knob (Ref. No. 23) to handle.
2. Slide table (Ref. No. 13) into hole in table arm. Secure table with table locking handle (Ref. No. 11).

MOUNT HEAD ASSEMBLY

Refer to Figure 9.

▲ WARNING *Although compact, the drill press head assembly is heavy. Two people are required to mount the drill press head assembly onto the column.*

1. Slide drill press head assembly onto top of column.
2. Position head so that it is centered over base.
3. Secure head by tightening the set screws (Ref. No. 36) on the right side of the head casting.

MOUNT QUILL FEED HANDLE ASSEMBLY

Refer to Figure 8.

1. Place key (Ref. No. 32) into key way of pinion (Ref. No. 33).
2. Place quill feed handle assembly (Ref. No. 34) over pinion.
3. Secure handle assembly with tap screw (Ref. No. 36) and plate (Ref. No. 35).
4. Thread quill feed knob (Ref. No. 37) onto quill feed handle assembly.

INSTALL CENTER PULLEY ASSEMBLY

Refer to Figures 8 and 9.

1. Loosen belt tension knobs (Fig. 8, Ref. No. 38) and use belt tension handle (Fig. 8, Ref. No. 43) to move motor toward front of drill press.
2. Open cover of pulley housing (Fig. 9, Ref. No. 2) and insert center pulley assembly (Fig. 8, Ref. No. 8) into the head casting.
3. Choose a speed from Figure 5 or the pulley housing speedchart and connect spindle pulley to center pulley with front drive belt (Fig. 8, Ref. Nos. 2, 7 and 8). Connect center pulley to motor pulley with rear drive belt (Fig. 8, Ref. Nos. 8, 54 and 55).
4. Turn handle (Fig. 8, Ref. No. 43) to move motor toward rear of drill press and tighten motor lock knobs.

NOTE: Front drive belt is type 270J4 and rear drive belt is type 300J4.

MOUNT CHUCK AND ARBOR

Refer to Figure 8.

1. Be sure spindle, arbor and chuck tapers are clean and dry. Make sure quill is completely retracted.
2. Use the provided chuck key (Ref. No. 31) to adjust the jaws of the chuck (Ref. No. 30) until they are recessed inside the drill chuck body.
3. Place drill chuck on a workbench face down. Arbor (Ref. No. 29) has a short taper and a long taper. Place short taper into top of drill chuck and tap with a rubber or wooden mallet.
4. Slide arbor into the spindle (Ref. No. 24) while slowly rotating drill chuck. Spindle has a rectangular pocket in which the tang fits into. Once tang is oriented correctly, drill chuck will not rotate without turning the spindle.

Dayton[®]



Dayton® 17" Floor Model Drill Press

ENGLISH

Assembly (Continued)

5. Tap the end of drill chuck with a rubber or wooden mallet to seat it into the spindle.

Hardware (Two M8 x 125 hex head bolts, M8 lock washers, M8 hex nuts and four M8 flat washers) has been provided for mounting the drill press to a wood base plate. This is recommended if you intend to place the drill press on a mobile base. The minimum recommended size of the wood base plate is 3/4 x 24 x 24".

Installation

Refer to Figures 2, 3 and 4.

POWER SOURCE

The motor is designed for operation on the voltage and frequency specified. Normal loads will be handled safely on voltages not more than 10% above or below the specified voltage.

Running the unit on voltages which are not within the range may cause overheating and motor burn-out. Heavy loads require that the voltage at motor terminals be no less than the voltage specified.

GROUNDING INSTRUCTIONS

⚠ WARNING *Improper connection of equipment grounding conductor can result in the risk of electrical shock. Equipment should be grounded while in use to protect operator from electrical shock.*

Check with a qualified electrician if grounding instructions are not understood or if in doubt as to whether the tool is properly grounded.

This tool is equipped with an approved 3-conductor cord rated at 300V and a 3-prong grounding type plug (See Figure 2) for your protection against shock hazards.

Grounding plug should be plugged directly into a properly installed and grounded 3-prong grounding-type receptacle, as shown in Figure 2.

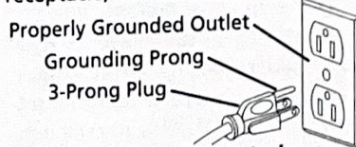

Figure 2 - 3-Prong Receptacle

Do not remove or alter grounding prong in any manner. In the event of a malfunction or breakdown, grounding provides a path of least resistance for electrical shock.

⚠ WARNING *Do not permit fingers to touch the terminals of plug when installing or removing from outlet.*

Plug must be plugged into matching outlet that is properly installed and grounded in accordance with all local codes and ordinances. Do not modify plug provided. If it will not fit in outlet, have proper outlet installed by a qualified electrician.

Inspect tool cords periodically, and if damaged, have repaired by an authorized service facility.

Green (or green and yellow) conductor in cord is the grounding wire. If repair or replacement of the electric cord or plug is necessary, do not connect the green (or green and yellow) wire to a live terminal.

Where a 2-prong wall receptacle is encountered, it must be replaced with a properly grounded 3-prong receptacle installed in accordance with National Electric Code and local codes and ordinances.

⚠ WARNING *This work should be performed by a qualified electrician.*

A temporary 3-prong to 2-prong grounding adapter (See Figure 3) is

available for connecting plugs to a two pole outlet if it is properly grounded.

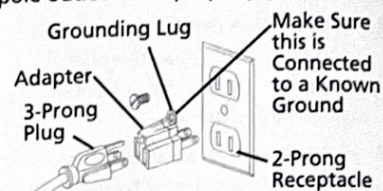

Figure 3 - 2-Prong Receptacle with Adapter

Do not use a 3-prong to 2-prong grounding adapter unless permitted by local and national codes and ordinances.

(A 3-prong to 2-prong grounding adapter is not permitted in Canada.) Where permitted, the rigid green tab or terminal on the side of the adapter must be securely connected to a permanent electrical ground such as a properly grounded water pipe, a properly grounded outlet box or a properly grounded wire system.

Many cover plate screws, water pipes and outlet boxes are not properly grounded. To ensure proper ground, grounding means must be tested by a qualified electrician.

EXTENSION CORDS

1. The use of any extension cord will cause some drop in voltage and loss of power.
2. Wires of the extension cord must be of sufficient size to carry the current and maintain adequate voltage.
3. Use the table to determine the minimum wire size (A.W.G.) extension cord.
4. Use only 3-wire extension cords having 3-prong grounding type plugs and 3-pole receptacles which accept the tool plug.
5. If the extension cord is worn, cut, or damaged in any way, replace it immediately.

Model 5PHC3B

ENGLISH

Installation (Continued)

EXTENSION CORD LENGTH (120 VOLTS)

Wire Size	A.W.G.
Up to 50 ft.	16
50-100 ft.	14
100-150 ft.	12

NOTE: Using extension cords over 150 ft. long is not recommended.

EXTENSION CORD LENGTH (240 VOLTS)

Wire Size	A.W.G.
Up to 50 ft.	18
50-200 ft.	16
200-300 ft.	14

NOTE: Using extension cords over 300 ft. long is not recommended.

ELECTRICAL CONNECTIONS

Refer to Figure 4.

▲ WARNING All electrical connections must be performed by a qualified electrician.

▲ WARNING Make sure tool is off and disconnected from power source while motor is mounted, connected, reconnected or any time wiring is inspected.

1. The motor should be wired for 120 volts and clockwise rotation as viewed from shaft end of motor.
2. A label on the motor describes the possible wiring configurations. There are many different possible combinations, so only the diagram provided with the motor should be used.
3. The motor cord must be secured to protect the wiring connections from possible strain.
4. The power supply to motor is controlled by a push button switch. Power lines are connected to the quick connect terminals of the switch.

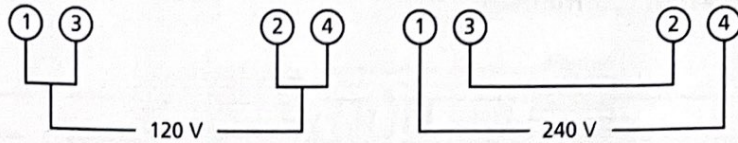

Figure 4 - Wiring Schematic for Motor

5. The green ground line must remain securely fastened to the motor ground terminal to provide proper grounding.
6. To operate drill press at 240 volts, rewire motor as shown in Figure 4 and replace line cord plug with a 240 volt, 15A, 3-prong plug. If motor label has a different wiring configuration, use the motor label diagram to rewire motor.

Recommended Dayton plugs, connectors and receptacles for 240 volts:

20 Amps Plug	250 Volts Connector	NEMA L6-20 Receptacle
5A081	5A082	5A080

30 Amps Plug	250 Volts Connector	NEMA L6-30 Receptacle
5A087	5A088	5A086

Operation

Refer to Figures 5-9.

STARTING AND STOPPING THE DRILL PRESS

Refer to Figure 8.

▲ WARNING Be sure drill bit is not in contact with workpiece when motor is started. Start motor and allow bit to come up to full speed before drilling.

1. The ON/OFF switch (Ref. No. 15) is located on the front of the head casting.
2. To turn the drill press on, push green ON button. Always allow drill bit to come up to speed before drilling.

3. To turn the drill press off, press the large red OFF paddle or lift the paddle and press directly on the red OFF button. Do not leave drill press until the bit has come to a complete stop.

SPEED ADJUSTMENTS

Refer to Figures 5 and 8.

▲ WARNING Be sure drill press is turned off and is disconnected from power source before adjusting speeds.

1. To change spindle speed, loosen motor lock knobs (Ref. No. 38), turn handle (Ref. No. 43) to move the motor toward front of drill press. This will loosen the belt and permit relocating the belt to the desired pulley groove for the required spindle speed (See Figure 5, page 6).
2. After belt has been repositioned, turn handle to move motor toward rear of drill press and tighten motor lock knobs.
3. Check belt for proper tension and make any final adjustment. A belt is properly tensioned when light pressure applied to midpoint of the belt produces about 1/2" deflection.

TABLE ADJUSTMENTS

Refer to Figure 7.

1. Height adjustments: To adjust table, loosen locking handle (Ref. No. 18) and turn crank handle (Ref. No. 23) to desired height. Immediately retighten table bracket locking handle.



Dayton® 17" Floor Model Drill Press

ENGLISH

Operation (Continued)

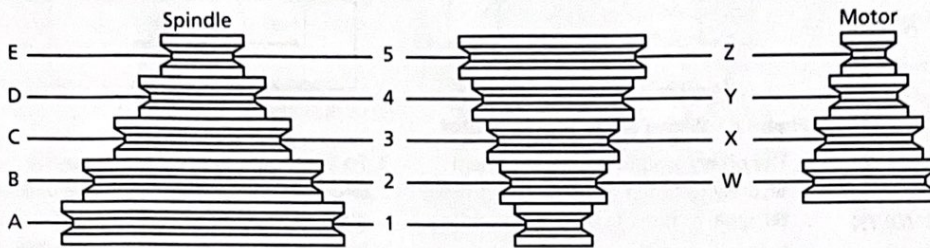

RPM	Belt Location
138	A1-5Z
257	B2-5Z
304	A1-4Y
344	C3-5Z
461	D4-5Z
497	A1-3X
566	B2-4Y
708	A1-2W
755	C3-4Y
927	B2-3X
1491	E5-4Y
1660	D4-3X
1761	C3-2W
2362	D4-2W
2444	E5-3X
3476	E5-2W

Figure 5 - Spindle Speed Adjustment

RPM	Wood		Zinc Diecast		Alum. & Brass		Plastic		Cast Iron & Bronze		Steel - Mild & Malleable		Steel - Cast & Med. Carbon		Steel - Stainless & Tool	
	in.	mm	in.	mm	in.	mm	in.	mm	in.	mm	in.	mm	in.	mm	in.	mm
3476	5/16	7.9	3/16	4.8	11/64	4.4	5/32	4.0	7/64	2.8	3/32	2.4	1/16	1.6	1/32	0.8
2362	5/8	15.9	3/8	9.5	11/32	8.7	5/16	7.9	1/4	6.4	5/32	4.0	1/8	3.2	1/16	1.6
1660	7/8	22.2	1/2	12.7	15/32	11.9	7/16	11.1	11/32	8.7	1/4	6.4	3/16	4.8	1/8	3.2
566	1 1/4	31.8	3/4	19.0	11/16	17.5	5/8	15.9	1/2	12.7	3/8	9.5	5/16	7.9	1/4	6.4
497	1 1/4	31.8	3/4	19.0	11/16	17.5	5/8	15.9	1/2	12.7	3/8	9.5	5/16	7.9	1/4	6.4
344	1 5/8	41.3	7/8	22.2	3/4	19.0	13/16	20.6	5/8	15.9	1/2	12.7	7/16	11.1	3/8	9.5
257	2	50.8	1	25.4	—	—	—	—	—	—	—	—	9/16	14.3	1/2	12.7

2. Rotation of work table: Loosen table locking handle (Ref. No. 18) and rotate table (Ref. No. 13) to desired position and retighten handle.
3. Tilting work table: Loosen table bolt (Ref. No. 10). Remove pin and nut (Ref. No. 9). To do this, tighten nut until pin slips out easily. Tilt table to desired angle up to 45° and retighten table bolt. Reinsert pin and nut when returning the table to 0° position.
4. To obtain more distance between chuck and table, the work table can

be rotated 180° and base can be used as a work surface. This permits drilling of larger objects.

5. Clamp table securely after adjustments have been made.

DEPTH STOP ADJUSTMENT
Refer to Figure 8.
To control drilling depth, use scale (Ref. No. 16) to adjust to desired depth. Depress and hold pin, slide depth stop nut (Ref. No. 15) along lead screw until bottom edge of nut coincides with the desired depth on the scale, then release

pin. Use this feature to drill more than one hole to the same depth.

MOUNT DRILL BIT

Refer to Figure 8.

⚠ WARNING *Be sure drill press is turned off and is disconnected from power source before mounting drill bit.*

1. Place drill bit in jaws of chuck.
2. Tighten chuck with chuck key. Be sure to tighten chuck using all three positions on chuck body and remove key.



Models 5PHC3B

ENGLISH

Operation (Continued)

3. Use only the self-ejecting chuck key (Ref. No. 31) supplied with this drill press, or a duplicate key. Use of any other key might allow start up with the key still in the chuck. An airborne key could strike the operator and cause injury.

REMOVING THE CHUCK

Refer to Figures 8 and 9.

1. Rotate quill feed handle (Fig. 8, Ref. No. 34) until slot is exposed in the side of the quill (Fig. 8, Ref. No. 24) Lock quill in position using handle (Fig. 9, Ref. No. 30).
2. Rotate spindle until inner slot is aligned with outer slot. You will see through spindle when slots are properly aligned.
3. Insert the drift key (Fig. 8, Ref. No. 25) into the slots and tap lightly with hammer. The arbor and chuck will drop from spindle.

DIGITAL DISPLAY PANEL

Refer to Figure 6.

1. Display panel 'A' shows the depth of the spindle and spindle RPM.
2. Button 'B' turns power on and off to Display 'A'.
3. Button 'C': Press once for spindle depth in inches; press again for spindle depth in mm; press once again for spindle RPM.

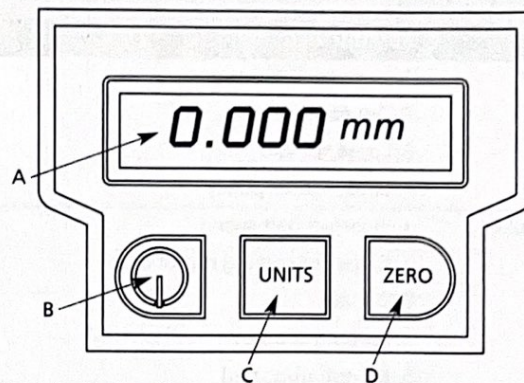

Figure 6 - Digital Display Panel

4. Button 'D' resets display at zero for spindle depth.

Maintenance

Refer to Figures 7 and 8.

WARNING Turn switch off and remove plug from outlet before maintaining or lubricating your drill press.

Replace worn drive belt when needed.

LUBRICATION

The ball bearings are lubricated at the factory and need no further lubrication. Using 20 wt. non detergent oil, periodically lubricate the splines (grooves) in the spindle and the rack (teeth on the quill) as follows:

1. Lower quill assembly (Fig. 8, Ref. No. 24) all the way down.

2. Apply lubricant around the inside of the hole in the spindle pulley (Fig. 8, Ref. No. 2) .
3. Apply lubricant to rack (teeth) on quill (Fig. 8, Ref. No. 24) while extended below drill press head.
4. Apply lubricant to rack and pinion gear (Fig. 7, Ref. Nos. 8 and 19) on column and table assembly.
5. Frequently blow out any dust that may accumulate inside the motor. If the power cord is worn, cut, or damaged in any way, have it replaced immediately. For motor lubrication, follow instructions on motor plate.



Dayton® 17" Floor Model Drill Press

E
N
G
L
I
S
H

Troubleshooting Chart

Symptom	Possible Cause(s)	Corrective Action
Noisy operation	<ol style="list-style-type: none"> 1. Incorrect belt tension 2. Dry spindle 3. Loose spindle 4. Loose motor pulley 	<ol style="list-style-type: none"> 1. Adjust tension 2. Lubricate spindle (See Lubrication) 3. Tighten pulley nut 4. Tighten set screw in pulley
Bit burns or smokes	<ol style="list-style-type: none"> 1. Incorrect belt speed 2. Chips not coming out of hole 3. Dull bit 4. Feeding too slow 5. Bit not lubricated 6. Bit running backwards 	<ol style="list-style-type: none"> 1. Change speed 2. Retract bit frequently to clear chips 3. Sharpen or replace bit 4. Feed faster; enough to allow drill to cut 5. Lubricate bit 6. Check motor rotation to be sure it is clockwise facing shaft end
Excessive drill runout or wobble	<ol style="list-style-type: none"> 1. Bent bit 2. Bit not properly installed in chuck 3. Chuck not properly installed 4. Worn spindle bearings 	<ol style="list-style-type: none"> 1. Replace bit 2. Install bit properly 3. Install chuck properly 4. Replace bearings
Drill bit binds in workpiece	<ol style="list-style-type: none"> 1. Workpiece pinching bit or excessive feed pressure 2. Improper belt tension 3. Workpiece not supported or clamped properly 	<ol style="list-style-type: none"> 1. Support or clamp work, decrease feed pressure 2. Adjust tension 3. Support or clamp workpiece securely
Spindle does not turn	<ol style="list-style-type: none"> 1. No power to drill press 2. Defective switch 3. Defective motor 	<ol style="list-style-type: none"> 1. Check wiring, fuse or circuit breaker 2. Replace switch 3. Replace motor
Noisy spindle	Defective bearings	Replace bearings