

SENCOR®

SVC 9486BK
SVC 9476BK
SVC 9466BK



STICK VACUUM CLEANER WITH COLLECTION STATION

Translation of the original manual



SENCOR®

**SVC 9486BK
SVC 9476BK
SVC 9466BK**



A

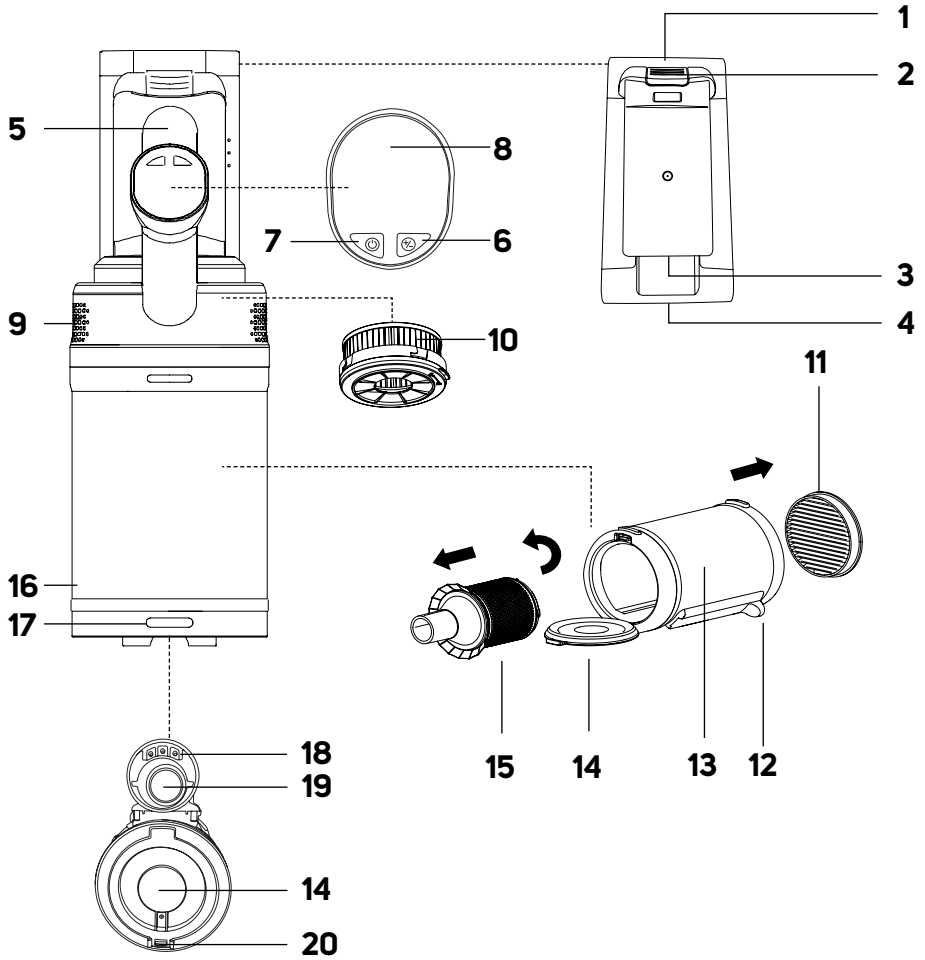

B

B1



B1.1

B1.2

B2

B2

B2.1

B2.2

B2.3

B2.4

B2.5

B2.6

B2.7

B2.8

B2.10

B2.9

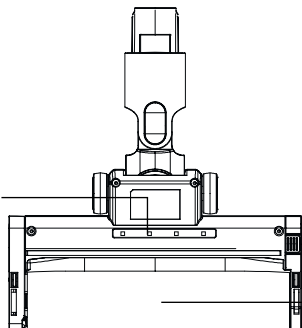
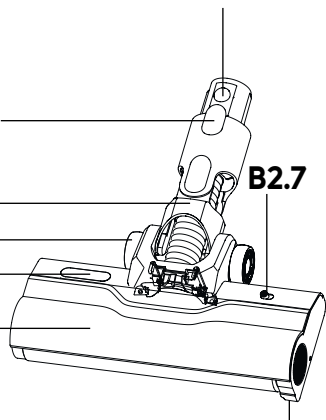

B3

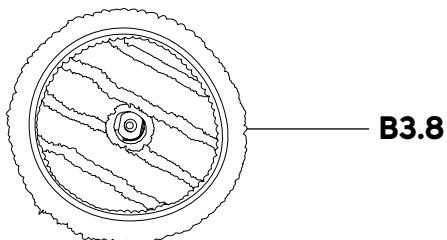
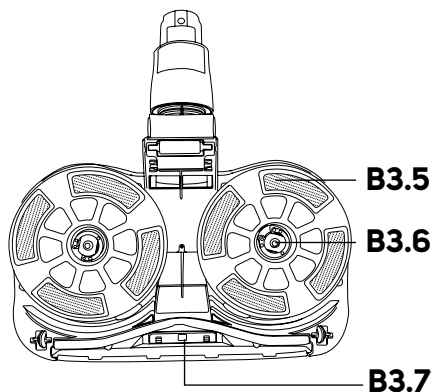
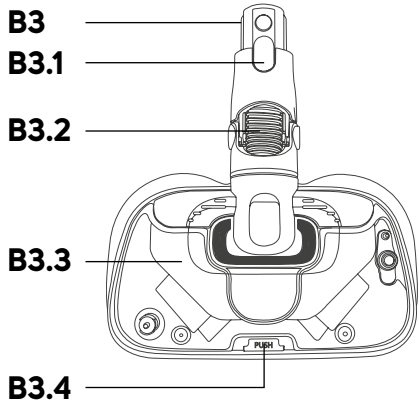

B4

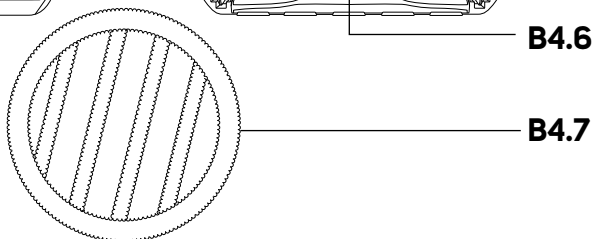
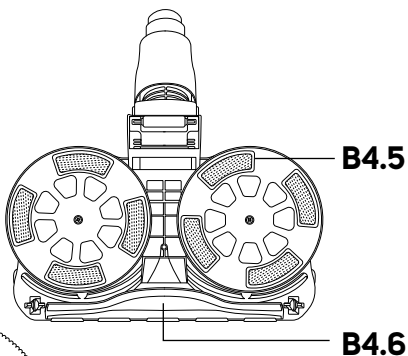
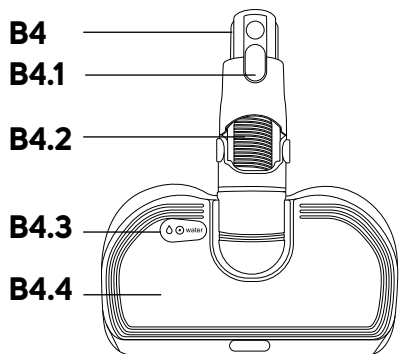

B5

B5

B5.1

B5.2

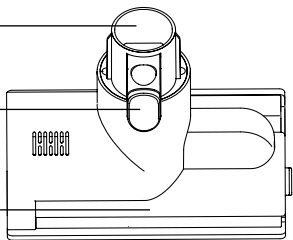

B5.4

B5.5

B5.6

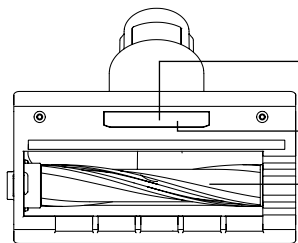

B6

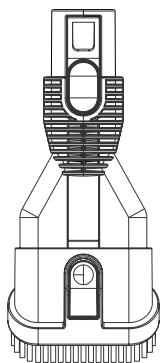

B7



B8

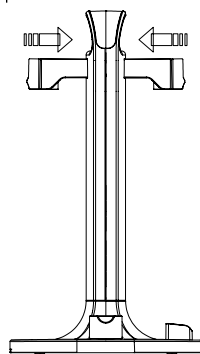

C

1

2

3

5

4

6

7

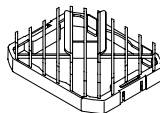
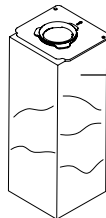
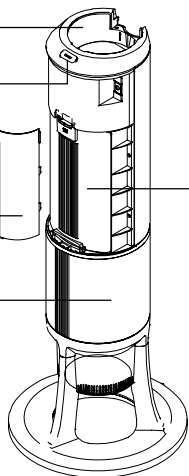

D

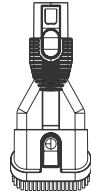
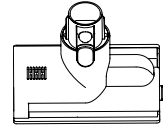
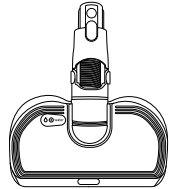
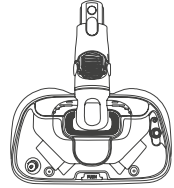
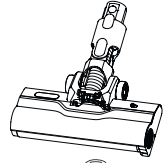
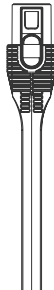
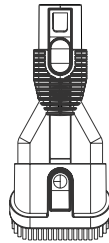
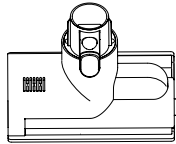
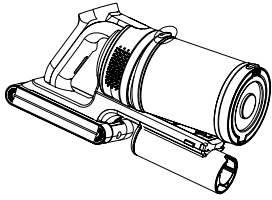

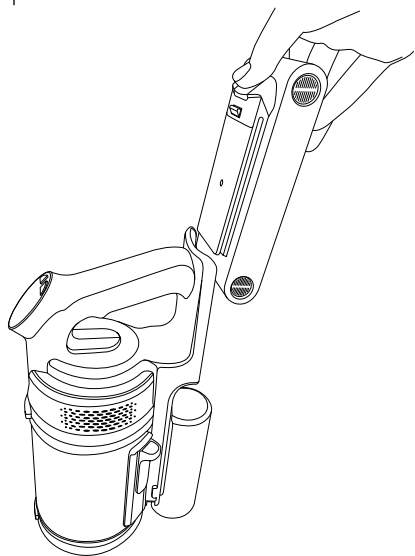
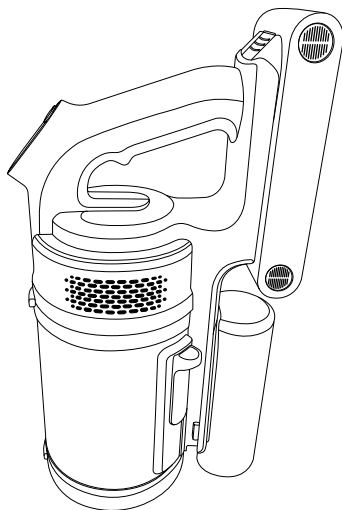
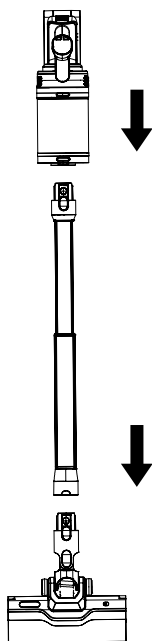
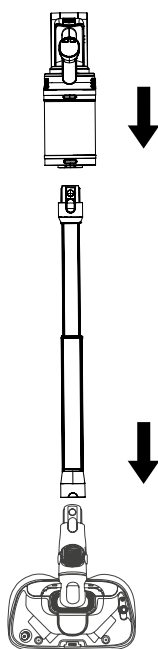
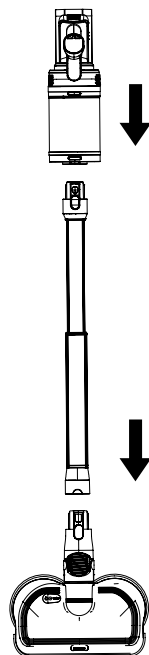
E1**E2****E3****E4****E5**

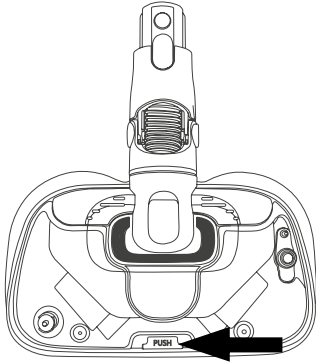
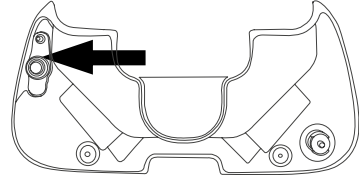
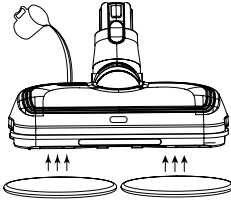
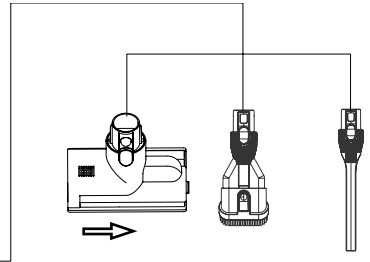
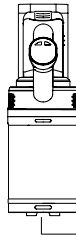
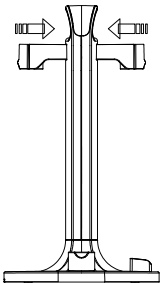
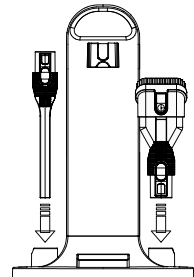
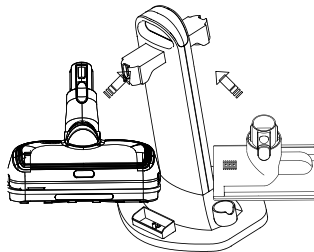
E6**E7****E8****E9****E10****E11**

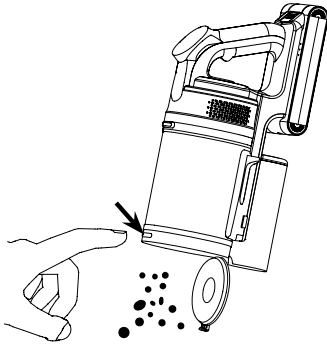
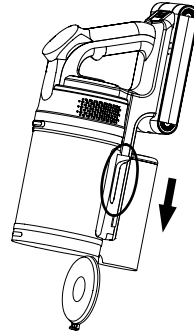
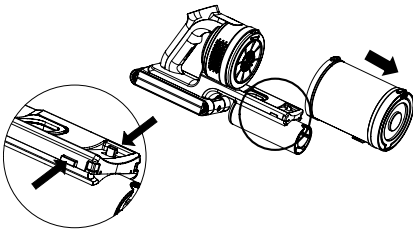
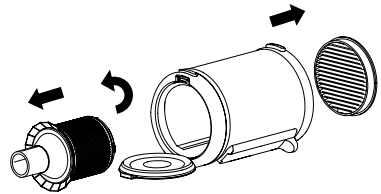
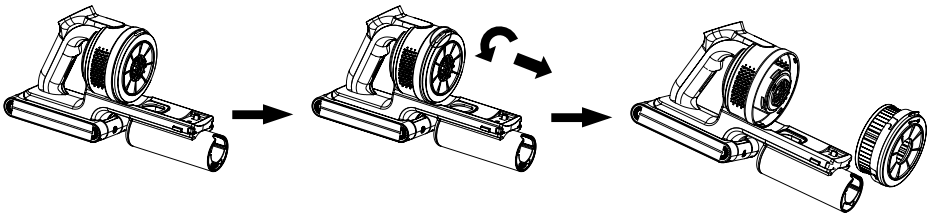
F1**F2****G1****G2****G3**

G4

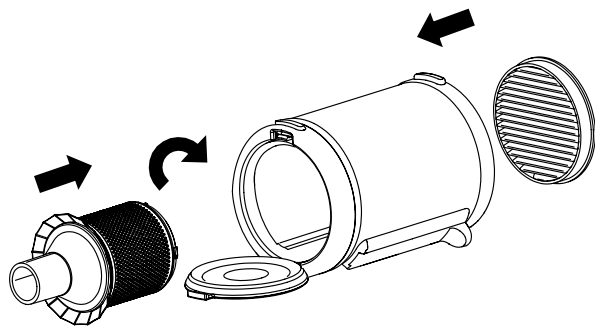

G5

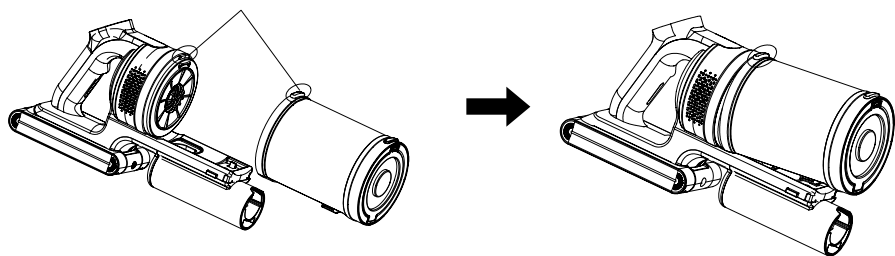

H

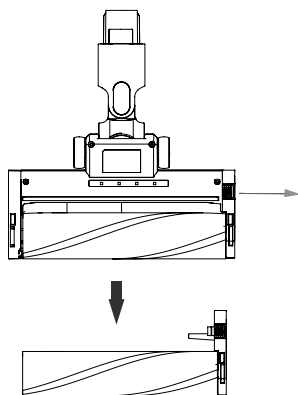

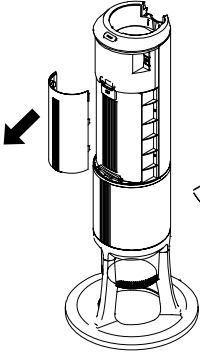
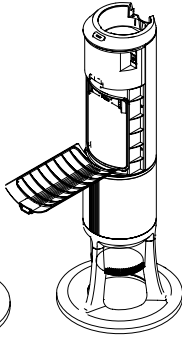
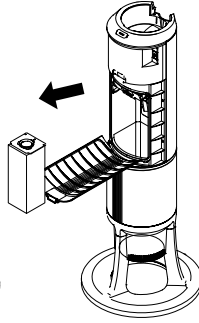
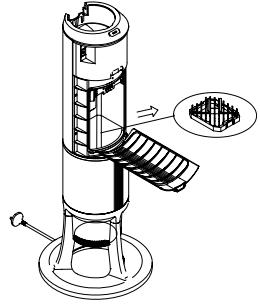
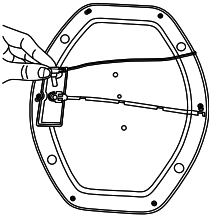
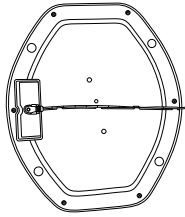
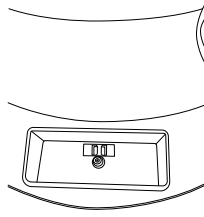
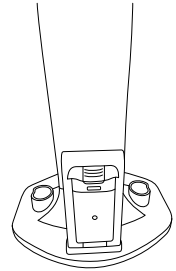
I1**I2****I3****I4****J1****J2****J3****J4**

IMPORTANT SAFETY INSTRUCTIONS

READ CAREFULLY AND STORE FOR FUTURE USE.

- This appliance may be only used by children aged 8 years and older and by persons with physical, sensory or mental impairments or lack of experience and knowledge, if they are supervised or have been instructed on the safe use of the appliance and understand the potential hazards.
- Children must not play with the appliance. Cleaning and maintenance must not be performed by unsupervised children.
- If the mains cable is damaged, have it replaced in a professional service centre in order to prevent a dangerous situation. It is forbidden to use the appliance with the cable damaged.
- The vacuum cleaner must be switched off and must not be charging, and the battery must be removed during cleaning or maintenance.
- The vacuum cleaner accessories contain rotating brushes and there is a risk of being caught by these parts in the event of incorrect handling.
- Use the vacuum cleaner only with accessories that are supplied with it or that the manufacturer recommends. Do not use other accessories. This could lead to a dangerous situation, property damage or electric shock.

- Do not immerse any part of the vacuum cleaner or its accessories in water or other liquid during cleaning. There is a risk of injury by electrical shock.
- Regularly inspect the condition of the vacuum cleaner and its accessories to ensure they are not damaged. Damaged cleaner or damaged accessories must not be used. There is a risk of electrical shock or damage to property.

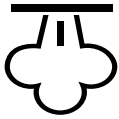

Warning:

Danger of scalding. Do not reach into the area where the steam is coming out, as it is very hot and may cause injury.

Additional Important Safety Instructions for Use of the Appliance

- This vacuum cleaner is designed for use in households, offices and similar types of areas. Do not use in industrial settings. Do not use it outdoors.
- Do not expose the vacuum cleaner to direct sunlight and do not place it near an open fire or appliances that are a source of heat. Avoid using or storing the cleaner in an environment where flammable, volatile, or explosive substances are used or stored.
- Before connecting the adapter to a mains socket check that the technical details on its rating label match the electrical voltage in the socket.
- Connect the adapter only to a properly earthed mains socket.
- Do not short-circuit the connectors of the vacuum cleaner or battery.
- Do not touch the connectors with wet or dirty hands.
- The recommended operating temperature is 0 to 40 °C. Do not use the vacuum cleaner at lower or higher temperatures.
- Ensure that the adapter and its cable do not come into contact with hot surfaces or sharp objects.
- Do not immerse the vacuum cleaner in water or other liquid, nor rinse it under running water, unless the manufacturer states otherwise.
- Before switching on the vacuum cleaner, ensure that it is correctly assembled.
- Ensure that during operation of the vacuum cleaner, the air outlet openings or the suction opening are not blocked.
- Do not use accessories for vacuuming water or other liquids.
- Do not use the vacuum cleaner to vacuum:
 - smouldering cigarettes, burning objects, matches or hot ashes;
 - flammable or volatile substances;
 - sharp objects such as shards, needles, pins, etc;
 - flour, plaster, cement and other building materials;
 - larger pieces of paper or plastic bags, which can easily block the suction opening.
- Vacuuming certain types of floor coverings may create electrostatic charge, which poses no danger to the user.
- Exercise increased caution when using the vacuum cleaner on stairs.
- Do not apply the suction parts to any parts of the face or body.
- Always switch off the vacuum cleaner and remove it from the charging base if you will be assembling, disassembling or changing accessories.
- Disconnect the mains cable from the socket by pulling the plug, not the cable. Otherwise, you may damage the mains cable or the socket.
- Keep the appliance clean. Wipe the outer surface with a clean, dry sponge. Follow the cleaning instructions provided in this manual.
- Clean the appliance after each use according to the instructions in the CLEANING AND MAINTENANCE section.
- Do not use the cleaner if it does not operate properly, has been damaged, or has been submerged in water.
- Do not attempt to repair or modify the cleaner yourself. All repairs should be carried out by an authorised service centre. Tampering with the appliance may result in the loss of your legal rights regarding faulty performance or warranty for quality.

Special Safety Instructions for the Collection Station

- Read the user manual before charging.
- The collection station is intended for indoor use only. Do not expose the collection station to rain, dripping or splashing water.
- This collection station is intended, among other things, for charging only Sencor brand batteries for vacuum cleaner models SVC 9486xx, SVC 9476xx or SVC 9466xx.



Warning

Do not use the collection station to charge other batteries that are not intended for this purpose.

- During charging, the collection station must be located in a well-ventilated area.
- Before connecting the mains cable to a mains socket, ensure that the input voltage stated on its type plate corresponds to the electrical voltage of your socket.
- Place the collection station on a flat, dry and solid surface. Ensure there is free space around it for air circulation and handling.
- Before use, check that the dust bag is installed. Do not use the collection station without a dust bag.
- Do not place the collection station near open fire or other heat sources. Do not expose it to direct sunlight.
- Check that the mains cable does not come into contact with hot surfaces or sharp objects. Position the mains cable so that it cannot be tripped over or stepped on.
- Do not cover or block the air outlet and inlet openings.
- Disconnect the mains cable from the mains socket before replacing the dust bag, cleaning, moving or storing the collection station.
- Do not touch the mains cable or plug with wet or damp hands.
- Disconnect the mains cable plug from the mains socket by pulling the plug, not the cable. Otherwise, the plug or socket could be damaged.
- Do not use the collection station if it is not functioning properly, has been damaged or immersed in water.

Warning When Charging the Battery

- Use only the supplied charging and storage base to charge the battery. Ensure that the base is connected to a power source.
- We recommend fully charging the battery before use.
- Before placing the cleaner in the charging base, make sure that the contacts on the cleaner and on the charging base are clean and dry.
- Do not leave the cleaner unattended while it is charging.
- Do not charge the cleaner near flammable materials or objects or at high ambient temperatures. We recommend charging the cleaner at temperatures between 5 and 40 °C.
- Do not expose the cleaner to direct sunlight during charging.
- Ensure sufficient clearance around the cleaner. Do not cover the cleaner while charging.
- Regularly check the charging base or the cleaner for damage. Do not charge the cleaner if the battery is visibly damaged, inflated, or has fallen into water.
- During charging, the battery and the part of the base in which the cleaner is located may heat up. This is normal. If these parts become very hot, disconnect the mains cable plug from the mains socket and allow the cleaner to cool down. Then start charging again. If the problem persists, disconnect the mains cable plug from the mains socket and contact an authorised service centre.

Safety Instructions for the Li-ion Battery

- Use only the battery supplied with the cleaner. Do not use the battery with another appliance or with this cleaner.
- Do not allow children to play with the battery.
- Always remove the battery from the motor unit before cleaning or maintenance.
- To remove the battery, first press the button on the battery and then remove it from the motor unit.
- Do not remove or apply force to the battery.
- Before switching on the cleaner, make sure that the battery is correctly inserted.
- The battery is intended for indoor use only. Do not use or store the battery in excessively dusty environments.
- Do not expose the battery to the outdoor environment, extreme temperatures, rapid temperature changes, heat, fire or direct sunlight.
- Keep the battery dry out of reach of children and pets. Do not expose it to moisture or immerse it in water or any other liquid.
- Do not make any adjustments to the battery.
- Do not use a battery whose power contacts show signs of damage or corrosion.
- Do not expose the battery to mechanical shocks. Do not disassemble, modify, throw into fire or expose the battery to high pressure.
- Do not short-circuit the battery power contacts. Do not store the battery in places where metal objects such as paper clips, coins, nails, screws, etc. could short circuit the power contacts. There is a risk of fire if a short circuit occurs.
- Do not use the battery if it is damaged, bloated or has fallen into water.
- Charge and use the battery in a dry environment at an ambient temperature of 5 to 40 °C.
- Incorrect use may cause fluid to leak out of the battery.
- In the event of a leak from the battery:
 - use gloves, goggles or other protective equipment (e.g. a breathing mask); do not handle the battery with unprotected hands;
 - place the battery on a non-flammable surface, ideally outdoors or in a well-ventilated place;
 - if there is a strong chemical smell, leave the room and ventilate it well, or leave the window or door open;
 - transfer the battery to a suitable container (a metal container with a lid or a plastic box that is resistant to chemicals and is lined with non-conductive loose material) and hand it in at a collection point or contact a specialist company for hazardous waste disposal;
 - never throw a damaged battery into ordinary waste.
- In case of skin or eye splashes, rinse with plenty of water and seek medical attention.
- In the event of ingestion, contact immediate medical help

Safety Instructions for Mains Adapters

- The supplied charging adapter is intended for Sencor brand models SVC 9486xx, SVC 9476xx or SVC 9466xx. Do not use the adapter for other models.

- This product is not a toy. Keep it out of reach of children and pets. Children must not play with the product. There is a risk of strangulation or suffocation.
- If the adapter is damaged, have it replaced in a professional service centre in order to prevent a dangerous situation. Do not use a damaged adapter.
- Only plug the adapter into a socket with a protective contact.
- Before connecting the adapter to a mains socket, ensure that the input voltage stated on the type plate corresponds to the electrical voltage of the socket.
- Connect the adapter only to a properly earthed socket. Do not use an extension cord.
- Do not disconnect the adapter from the socket by pulling the mains cable. This could damage the adapter or the socket. Disconnect the adapter from the socket by pulling the plug.
- Do not lay the adapter of the collection station over sharp objects. Ensure that the mains cable does not hang over the edge of a table or come into contact with a heated or hot surface. Route the mains cable so that it cannot be stepped on or tripped over. The mains cable must not be routed under carpets or furniture.
- Keep the adapter and its mains cable dry.
- Do not connect or disconnect the adapter mains cable to or from the mains socket with wet hands.
- To prevent electric shock, do not spray the adapter with water or immerse it in water or other liquids.
- When the adapter is in use, it heats up slightly. This is normal. If the adapter feels hot to the touch, disconnect it from the battery and allow it to cool down. If the problem persists, stop using the adapter and have it repaired at an authorised service centre.
- Ensure adequate ventilation for heat dissipation when using the adapter. Do not cover it during use. There is a risk of overheating and damage to the adapter or battery.
- Do not disassemble the adapter, expose it to extreme temperatures, dust, or moisture. Avoid mechanical damage.
- Do not modify or repair the adapter yourself. It does not contain parts that the user can repair themselves.
- Use only a dry cloth for cleaning.

EXPLANATION OF SYMBOLS PLACED ON THE PRODUCT OR IN THE ACCOMPANYING DOCUMENTATION



The product meets all the basic requirements of the applicable EU directives.



Used electrical and electronic products must not be disposed of in ordinary municipal waste.



Used accumulators and batteries do not belong in normal municipal waste.



The product is intended for household use only. The product is not intended for outdoor use.



Class II protection device

Protection against electric shock is ensured by double or reinforced insulation.





This symbol indicates that the appliance must not be used if the power plug is damaged.



Caution: Read the manual.

- Thank you for purchasing our SENCOR product; we hope it will serve to your satisfaction.
- Prior to using this appliance, please read the user manual thoroughly, even in cases when you are already familiar with the use of similar types of appliances. Use the appliance only as described in this user manual. Keep the manual for future reference. If you pass the appliance on to another person, ensure that this user manual is included.
- Carefully unpack the appliance and make sure not to discard any part of the packaging material until you have removed all its components. It is recommended that you keep the original packaging, packing material, receipt and confirmation of the extent of the seller's liability or warranty certificate at least for the duration of the legal right to file a defect claim or the quality warranty. When transporting the appliance, we recommend repackaging it in the original box provided by the manufacturer.

DESCRIPTION OF VACUUM CLEANER

A1 Battery	A13 Dust container
A2 Button to release the battery	A14 Hinged bottom of the dust container
A3 Battery charging connectors	A15 Tube filter
A4 Socket for connecting the charging adapter connector	A16 Buttons to release the dust container (located on the sides)
A5 Handle	A17 Button to release the bottom of the dust container
A6 Button  for selecting the vacuum cleaner mode	A18 Connectors for attaching accessories
A7 Button  to switch the vacuum cleaner on/off	A19 Opening for attaching accessories
A8 Display	A20 Dust container bottom lock
A9 Motor unit with ventilation openings	
A10 HEPA filter	
A11 Microfibre inlet filter	
A12 Sliding lever to release dirt from the tube filter	

DESCRIPTION OF ACCESSORIES

B1 Telescopic tube	B1.2 Button to adjust the length of the telescopic tube
B1.1 Button to release the telescopic tube	
B2 Motorised brush nozzle for dry vacuuming	B2.6 LED light
B2.1 Button to release the dry vacuuming nozzle	B2.7 Switch to turn the LED light on/off
B2.2 Flexible joint	B2.8 UV light
B2.3 Drive castors	B2.9 Soft rotating brush
B2.4 Dust level indicator	B2.10 Button to remove the rotating brush
B2.5 Rotating brush front cover	
B3 Steam mopping nozzle (SVC 9486BK model only)	B3.5 Mopping pad holders
B3.1 Button to release the steam mopping nozzle	B3.6 Water/steam discharge nozzles
B3.2 Flexible joint	B3.7 LED light
B3.3 Water tank	B3.8 Mopping pads
B3.4 Button to release the water tank	

B4 Mopping nozzle (SVC 9476BK model only)	B4.3 Water tank cap
B4.1 Button to release the mopping nozzle	B4.4 Water tank
B4.2 Flexible joint	B4.5 Mopping pad holders
	B4.6 Suction opening
	B4.7 Mopping pads

B5 Mattress and upholstery nozzle	B5.3 Rotating lock to release the rotating brush
B5.1 Button to release the nozzle	B5.4 Sensor
B5.2 Rotating brush protective cover	B5.5 UV light
	B5.6 Rotating brush

B6 Nozzle with retractable soft brush	B7 Long crevice nozzle
	B8 Accessory holder

DESCRIPTION OF THE COLLECTION STATION

C1 Space for inserting the vacuum cleaner	C5 Base
C2 ON/OFF button	C6 Dust bag
C3 Outer cover	C7 Filter cover
C4 Dust bag cover	Not shown: foam filter

PACKAGE CONTENTS

SVC 9486BK

- Vacuum cleaner (motor unit with 2 batteries and dust container)
- Telescopic tube
- Motorised brush nozzle for dry vacuuming
- Steam mopping nozzle
- Mopping pads (6 pcs)
- Mattress and upholstery nozzle
- Nozzle with retractable soft brush
- Long crevice nozzle
- Accessory holder
- Collection station
- Dust bag (3+1, 1 bag is installed in the collection station)

SVC 9476BK

- Vacuum cleaner (motor unit with battery and dust container)
- Telescopic tube
- Motorised brush nozzle for dry vacuuming
- Mopping nozzle
- Mopping pads (6 pcs)
- Mattress and upholstery nozzle
- Nozzle with retractable soft brush
- Long crevice nozzle
- Accessory holder
- Collection station
- Dust bag (3+1, 1 bag is installed in the collection station)

SVC 9466BK

- Vacuum cleaner (motor unit with battery and dust container)
- Telescopic tube
- Motorised brush nozzle for dry vacuuming
- Mattress and upholstery nozzle
- Nozzle with retractable soft brush
- Long crevice nozzle
- Accessory holder
- Collection station
- Dust bag (3+1, 1 bag is installed in the collection station)

INTENDED USE

- The vacuum cleaner is intended, thanks to its rich accessories, for cleaning various surfaces and places in your household. **For options on how to combine the accessories with each other, see figure D.**
- **The motorised brush nozzle for dry vacuuming** is intended for vacuuming dust and dirt from both smooth surfaces (e.g. wooden or laminate floating floors), hard floors (e.g. tiles, vinyl), as well as carpets, mats, runners, etc.
- **The steam mopping nozzle** (SVC 9486BK model only) is intended for cleaning hard floors such as wooden or laminate floating floors, tiles, vinyl, etc. We recommend checking with the floor manufacturer whether the steam mopping nozzle can be used on the given type of flooring. Thanks to the generation of hot steam, it ensures a hygienically clean mopped floor. This nozzle is not intended for cleaning carpets or runners.
- **The mopping nozzle** (SVC 9476BK model only) is intended for cleaning hard floors such as wooden or laminate floating floors, tiles, vinyl, etc. We recommend checking with the floor manufacturer whether the mopping nozzle can be used on the given type of flooring. This nozzle is not intended for cleaning carpets or runners.
- **The mattress and upholstery nozzle** is intended for removing dust, dirt, hair or animal fur from mattresses, upholstered furniture, cushions and other textile surfaces. You can use it not only at home, but also in your car. It quickly and effectively removes hair, animal fur and other dirt, e.g. from car seats.
- **The nozzle with retractable soft brush** is suitable for vacuuming dirt and dust from fragile objects, bookshelves, walls, blinds, furniture, etc.
- **The long slot nozzle with illumination** is suitable for vacuuming in hard-to-reach places (e.g. windows, corners, bookcases, spaces between mattresses, upholstery, etc.).
- **The collection station** serves to extract dirt and dust from the dust container. These are collected in the dust bag. When the bag is full, the collection station alerts you to replace it.

VACUUMING MODES

The vacuum cleaner is equipped with three operating modes:

1. **Eco** mode: mode with reduced suction power and maximum consideration for battery life.
2. **Auto** mode: the vacuum cleaner automatically adjusts the suction power according to the type of surface being vacuumed and the degree of soiling. This conserves battery capacity, and thus its overall lifespan. **This mode is available only for dry vacuuming.**
3. **Max** mode: mode with the highest suction power.

SETUP BEFORE USE

- Remove the vacuum cleaner, collection station and all accessories from the packaging. Check that you have removed all parts. Check that the vacuum cleaner and its accessories are not damaged.
- Remove protective films and promotional labels from the vacuum cleaner, collection station and all accessories.

Charging the vacuum cleaner

- The vacuum cleaner can be charged using the supplied mains adapter or in the collection station.

Charging using the mains adapter

- To charge the vacuum cleaner, use only the supplied mains adapter.
- Before use, we recommend fully charging the vacuum cleaner.
- Insert the adapter plug into a properly earthed mains socket. Insert the connector into the socket in the battery.
- Charging will start automatically. The charge status will be displayed on the display. When the display shows 100% charge status, the vacuum cleaner is charged.
- Disconnect the connector from the socket in the battery and remove the adapter plug from the mains socket.
- The time to full charge is typically 4 hours.

Charging at the collection station

- Place the vacuum cleaner in the collection station.
- Charging will start automatically. The charge status will be displayed on the display. When the display shows 100% charge status, the vacuum cleaner is charged. Charging will stop automatically.

Collection station

- Place the collection station on a solid and flat surface. Ensure sufficient free space around it for handling.
- Ensure that the collection station is located at a sufficient distance from the mains socket.
- Insert the mains cable plug into a properly earthed mains socket.

An Alternative battery charging method

- The spare battery can be charged directly in the accessory holder.
1. Insert the charging adapter connector into the battery compartment opening from below - see Figure **J1**.
 2. Guide the charging adapter cable through the groove at the bottom of the holder - see Figure **J2**.
 3. Place the accessory holder in a suitable place within reach of the mains socket and insert the adapter into it.
 4. Insert the spare battery into the designated space in the holder so that the charging adapter connector is inserted into the opening in the battery - see Figure **J3** and **J4**.



Note:

Only the SVC 9486BK comes with two batteries. For other models, a second battery must be purchased separately.

ASSEMBLY/DISASSEMBLY OF THE VACUUM CLEANER

Inserting/Removing the Battery

- Hold the battery with one hand and the motor unit with the other.
- Align the battery with the guide grooves in the space in the motor unit – see figure **E1**; and move it downwards to install the battery. Press gently until you hear a click. This indicates that the battery is correctly fitted.
- If you need to remove the battery, press the button to remove the battery and at the same time pull it upwards out of the motor unit – see figure **E2**.



Note:

With the exception of replacing the battery and cleaning the motor unit, it is not necessary to insert and remove it frequently.

Assembling/disassembling the vacuum cleaner with the dry vacuuming nozzle (Fig. E3)

- The vacuum cleaner is supplied disassembled. Follow these steps for assembly:
- Insert the end of the dry vacuuming nozzle into the wider opening of the telescopic tube. Ensure that the connectors at the rear of the telescopic tube are aligned with the connectors on the nozzle. Press gently until you hear a click. This indicates correct connection.
- Insert the narrower end of the telescopic tube into the accessory connection opening in the lower part of the motor unit. Ensure that the connectors at the rear of the telescopic tube are aligned with the connectors in the opening. Press gently until you hear a click. This indicates correct connection.
- If you need to disassemble the vacuum cleaner, hold the motor unit from below with one hand and press the button to release the telescopic tube with the other hand. Pull the telescopic tube away from the motor unit.
- Then hold the telescopic tube with one hand and press the button to release the dry vacuuming nozzle with the other hand. Pull the dry vacuuming nozzle away from the telescopic tube.

Assembling/disassembling the vacuum cleaner with the steam mopping nozzle (Fig. E4; SVC 9486BK model only)

- Insert the end of the steam mopping nozzle into the wider opening of the telescopic tube. Ensure that the connectors at the rear of the

telescopic tube are aligned with the connectors on the nozzle. Press gently until you hear a click. This indicates correct connection.

- Insert the narrower end of the telescopic tube into the accessory connection opening in the lower part of the motor unit. Ensure that the connectors at the rear of the telescopic tube are aligned with the connectors in the opening. Press gently until you hear a click. This indicates correct connection.
- Attach two mopping pads to the holders in the lower part of the nozzle. We recommend moistening the pads in clean water and wringing them out lightly before attaching. This will speed up mopping.
- If you need to disassemble the vacuum cleaner, hold the motor unit from below with one hand and press the button to release the telescopic tube with the other hand. Pull the telescopic tube away from the motor unit.
- Then hold the telescopic tube with one hand and press the button to release the steam mopping nozzle with the other hand. Pull the steam mopping nozzle away from the telescopic tube.

Assembling/disassembling the vacuum cleaner with the mopping nozzle (Fig. E5; SVC 9476BK model only)

- Insert the end of the mopping nozzle into the wider opening of the telescopic tube. Ensure that the connectors at the rear of the telescopic tube are aligned with the connectors on the nozzle. Press gently until you hear a click. This indicates correct connection.
- Insert the narrower end of the telescopic tube into the accessory connection opening in the lower part of the motor unit. Ensure that the connectors at the rear of the telescopic tube are aligned with the connectors in the opening. Press gently until you hear a click. This indicates correct connection.
- Attach two mopping pads to the holders in the lower part of the nozzle. We recommend moistening the pads in clean water and wringing them out lightly before attaching. This will speed up mopping.
- If you need to disassemble the vacuum cleaner, hold the motor unit from below with one hand and press the button to release the telescopic tube with the other hand. Pull the telescopic tube away from the motor unit.
- Then hold the telescopic tube with one hand and press the button to release the mopping nozzle with the other hand. Pull the mopping nozzle away from the telescopic tube.

Filling the water tank (steam mopping nozzle, SVC 9486BK model only)

1. Press the button to release the water tank (B3.4) and carefully remove the water tank from the nozzle – see figure E6.
2. Turn the tank upside down and release the cap – see figure E7. Pour water into the tank.
3. Close the cap, turn the tank upside down again and check that water does not leak. If it does not leak, insert the tank back into the nozzle by first inserting the upper part under the catches, and then press the lower part of the tank against the nozzle until you hear a click.

Filling the water tank (mopping nozzle)

1. Remove the water tank cap and pour clean water into the tank – see figure E8. Do not use any cleaning agents or chemicals.
2. Replace the cap and close it properly.

Assembling/disassembling the vacuum cleaner with other accessories (Fig. E9)

- Insert the narrower end of the mattress and upholstery nozzle, nozzle with retractable soft brush or long crevice nozzle into the accessory connection opening in the lower part of the motor unit. Ensure that the connectors at the rear of the telescopic tube are aligned with the connectors in the opening. Press gently until you hear a click. This indicates correct connection.
- If you need to remove the connected accessory, press the release button on the given accessory. Pull the given accessory away from the motor unit.



Accessory holder

- The accessory holder consists of 4 parts: bottom base, handle and 2 holders.
- Place the base on a solid and flat surface.

- Install the handle on the base and then attach the two accessory holders – see figure E10.
- Hang the mopping nozzle and mattress and upholstery nozzle each on one holder, and place the nozzle with retractable soft brush and long crevice nozzle on the projections at the bottom – see figure E11.

USING THE VACUUM CLEANER

Check that the vacuum cleaner is correctly assembled and fully charged.

1. Grasp the vacuum cleaner by the handle.
2. Press the button  once briefly and the vacuum cleaner will start in Eco mode.
3. By repeatedly pressing the button , select the vacuum cleaner mode: Eco – Auto – Power. The display will show a graphic representation of the selected mode and the remaining battery charge capacity.
4. Move the vacuum cleaner forwards and backwards.
5. After use, press the button  to switch off the vacuum cleaner.
6. Clean the vacuum cleaner according to the instructions in the CLEANING AND MAINTENANCE section.



Warning:

Do not drive the vacuum cleaner over thresholds, threshold strips or other obstacles or foreign objects.

Using the vacuum cleaner with the dry vacuuming nozzle

- The dry vacuuming nozzle is equipped with a rotating brush, UV light, LED light, dust sensor and indication of optimal brush operation. This nozzle is intended for vacuuming dust and dirt from both smooth surfaces (e.g. wooden or laminate floating floors), hard floors (e.g. tiles, vinyl), as well as carpets, mats, runners, etc.

UV light

- After switching on the vacuum cleaner, the UV light will automatically come on and will remain on for the entire time the vacuum cleaner is switched on.

LED light

- Move the switch to the on position and the LED light will come on. Move the switch to the off position and the LED light will go off.













Dust sensor and dust indication

- This function is available only in Auto mode and when using the dry vacuuming nozzle on the floor.
- The dry vacuuming nozzle is equipped with a dust sensor that sends a signal to the vacuum cleaner according to the amount of dirt or dust on the floor, and the vacuum cleaner automatically adjusts the suction power. At the same time, the indication on the nozzle (number **B2.4**) changes depending on whether the dust sensor detects dirt or dust.
- If the indication lights up green, low dust level is detected and the rotating brush is in optimal operation.
- If the indication lights up red, high dust level is detected. At this moment, the power will increase until the indication is green again.
- If the indication flashes red, the rotating brush has become blocked.

Using the vacuum cleaner with the steam mopping nozzle/ mopping nozzle

- Fill the water tank according to the instructions in the FILLING THE WATER TANK section – see the previous part of the manual for the given nozzle.
- Attach two mopping pads to the holders in the lower part of the nozzle. We recommend moistening them in clean water and wringing them out lightly before attaching. This will speed up mopping.
- The vacuum cleaner will vacuum dirt and at the same time wipe the floor.
- The steam mopping nozzle (model SVC 9486BK) and mopping nozzle (model SVC 9476BK) are equipped with LED light. The LED light will automatically come on and will remain on for the entire time the vacuum cleaner is switched on.

Overview of icons and their meaning on the display

ICON	MEANING	WHAT TO DO
	Eco mode: mode for daily cleaning with maximum consideration for battery life.	—
	Auto mode: the vacuum cleaner always optimally adjusts the suction power according to the type of surface being vacuumed and the degree of soiling. This conserves battery capacity, and thus its overall lifespan. This mode is available only for dry vacuuming of floors.	—
	Max mode: mode with the highest suction power for heavy soiling.	—
	Dirty sensor inside the suction opening in the joint of the floor nozzle.	Disconnect the floor nozzle from the tube. The sensor is located inside the nozzle joint. Carefully clean it with a soft, dry cloth or cotton swab. Ensure that no dirt or moisture remains in the sensor area. Reconnect the nozzle and switch on the vacuum cleaner. If the icon does not go off, repeat the process or contact an authorised service centre.
	Damage or incorrect function of the sensor located in the floor nozzle of the vacuum cleaner.	Switch off the vacuum cleaner and disconnect the floor nozzle from the tube. Check that the sensor and the nozzle surroundings are not dirty. If the sensor is clean and the icon remains displayed, contact an authorised service centre. Do not attempt to disassemble or repair the sensor yourself.
	The vacuum cleaner battery is almost flat.	The vacuum cleaner needs to be charged.
	Charging in progress.	—
	The vacuum cleaner is fully charged.	—
	The rotating brush of the dry vacuuming nozzle is blocked.	Clean the rotating brush and remove the cause of blockage.
	The airflow in the vacuum cleaner is blocked. The cause may be a blocked nozzle, tube, dust container, filter or other part of the suction system.	Switch off the vacuum cleaner. Check that the following parts are not blocked: floor nozzle and suction opening, tube and connecting parts, dust container, filters (inlet and outlet). Remove all dirt and check that all parts are correctly seated. Switch on the vacuum cleaner. If the icon disappears, airflow has been restored.
	The water tank in the steam mopping nozzle is empty or not correctly installed. The appliance cannot generate steam until water is added.	Switch off the vacuum cleaner and disconnect it from power. Remove the water tank. Fill it with clean water. Ensure that the tank is correctly and firmly installed. Switch on the vacuum cleaner. If the icon does not go off, repeat the process or contact an authorised service centre.
	Steam discharge mode of the steam mopping nozzle.	—
	Steam discharge mode of the steam mopping nozzle in combination with eco vacuuming mode.	—

Using the collection station

- The default emptying mode for the dust container is automatic mode. In automatic mode, the ON/OFF button is lit.
- Before placing the vacuum cleaner in the collection station and emptying the dust container, we recommend pressing the sliding lever **(A12)** several times to release dirt, tangled hair and fur, etc. from the coarse filter.
- Place the vacuum cleaner in the opening in the collection station.
- The dust container emptying process will start automatically. The bottom of the dust container will open, dust and dirt will be extracted from the container, and the bottom of the dust container will close. The entire process consists of three cycles and takes approximately 30 seconds. Wait until the process is complete. The process is complete when the bottom of the dust container closes. You will hear the bottom closing and a gentle click.



Note:

If you remove the vacuum cleaner from the collection station whilst the collection station is operating, the bottom of the dust container may remain open.



Warning:

Do not remove the vacuum cleaner from the collection station whilst the dust container is being emptied.

- **Manual mode (night mode):** Press and hold the ON/OFF button for 3 seconds and the collection station will switch to manual dust container emptying mode. The ON/OFF button will go off. After placing the vacuum cleaner in the station, the dust container emptying process will not start. Only when you press the ON/OFF button briefly will the dust container emptying process start. The bottom of the dust container will open, dust and dirt will be extracted from the container, and the bottom of the dust container will close. The entire process consists of three cycles and takes approximately 30 seconds. Wait until the process is complete. The process is complete when the bottom of the dust container closes. You will hear the bottom closing and a gentle click. The ON/OFF button will go off.
- To switch back to automatic mode, press and hold the ON/OFF button.
- **Full dust bag warning:** If the ON/OFF button flashes red, the dust bag is full. The collection station can be used normally, however we recommend replacing the dust bag. When replacing, follow the instructions in the REPLACING THE DUST BAG section.
- **Missing dust bag warning:** If the ON/OFF button lights up red for 5 seconds and then goes off, the dust bag is not installed and the collection station cannot be used. Install the dust bag.

Storing the vacuum cleaner

- If you will not be using the vacuum cleaner, clean it according to the instructions in the CLEANING AND MAINTENANCE section and store it in the collection station. It also serves as a stand for storing the vacuum cleaner.
- Store accessories (mopping nozzle, mattress and upholstery nozzle, nozzle with retractable soft brush and long crevice nozzle) in the holder.



Warning:

Avoid storing the vacuum cleaner and its accessories in direct sunlight, near heat sources (e.g. stoves, heating) or in a damp or dusty environment.

CLEANING AND MAINTENANCE

- The vacuum cleaner must be switched off before cleaning. When cleaning the motor unit, the battery must be removed.
- Never use abrasive cleaning agents, solvents, etc. for cleaning.
- Neglecting cleaning and maintenance may negatively affect the working order of the vacuum cleaner and lead to its reduced performance.
- For everyday cleaning and maintenance, wipe the body of the vacuum cleaner and collection station with a dry cloth.



Warning:

Do not immerse the motor unit, battery, collection station or mains cable in water or other liquid. There is a risk of injury by electrical shock.

Emptying the dust container

- The dust container can be emptied in two ways: into the dust bag in the collection station or manually. The procedure for emptying into the dust bag in the collection station is described in the previous part of the manual USING THE COLLECTION STATION. For manual emptying, proceed as follows.
- Disconnect the motor unit and remove the battery.
- Move the motor unit over the trash can so that the bottom of the dust container is pointing down.
- Press the button to release the bottom of the dust container – see figure **F1**. The bottom will release and the contents of the container will fall into the bin.
- We recommend pressing the sliding lever **(A12)** several times to release dirt, tangled hair and fur, etc. from the coarse filter – see figure **F2**.
- Use your free hand to attach the bottom back to the container. Press gently until you hear a click. This indicates that the bottom has been properly secured.

Cleaning the Dust Container

- Empty the dust container according to the instructions above.
- Press the buttons to release the dust container and remove it from the motor unit – see figure **G1**.
- Remove the microfibre inlet filter from the upper part. Open the bottom of the dust container, grasp the tube filter by hand and turn it clockwise to release it. Remove the tube filter from the dust container – see figure **G2**.
- Grasp the HEPA filter with one hand and turn it anticlockwise (in the direction of the open lock arrow marked on the HEPA filter) to release it and remove it from the motor unit – see figure **G3**.
- Remove dirt from the tube filter. If necessary, you can rinse it under running water. And then wipe dry with a clean cloth.
- Shake out the HEPA filter and microfibre inlet filter and remove dirt from them using a soft brush or dry cloth. In the event of heavy soiling, you can vacuum them out using a different vacuum cleaner with an attached brush nozzle. Do not wash them in water. This may lead to their damage. If the HEPA filter or microfibre inlet filter are already heavily soiled, damaged or deformed, replace them with new ones. We recommend changing the HEPA filter and microfibre inlet filter depending on the frequency of use, at least once every six months.
- Wipe the inner walls of the dust container with a slightly moistened soft sponge. Wipe dry with a clean cloth.



Warning:

Never install the filters if they are wet or damp. Before installing them, make sure that they are thoroughly dry.

- Insert the tube filter into the dust container and turn it anticlockwise to secure it. Close the bottom of the dust container. Insert the microfibre inlet filter in the upper part – see figure **G4**.

- Place the HEPA filter against the motor unit and turn the filter clockwise (in the direction of the open-lock arrow marked on the HEPA filter) until you feel resistance.
- Place the dust container against the motor unit at a right angle so that the projection at the front of the motor unit fits into the opening in the upper part of the dust container – see figure **G5**.
- Then press the lower part of the dust container against the motor unit. Press gently until you hear a click. This indicates the correct attachment of the dust container.

Cleaning the dry vacuuming nozzle

- Remove the telescopic tube from the nozzle.
- Press the button to release the rotating brush and pull it out of the nozzle – see figure **H**.
- Remove hair and fur entangled in the brush. You can use scissors, for example, to release or remove them.
- Wipe the nozzle, especially the suction opening, with a soft sponge slightly dampened in warm water. Wipe with a dry cloth.
- Insert the rotating brush back into the nozzle. Press gently until you hear a click. This indicates that the brush is properly secured.



Warning:

Do not submerge the nozzle in water or wash it under water. There is a risk of damage and injury by electric shock.

Cleaning the steam mopping nozzle (SVC 9486BK model only)

- Remove the telescopic tube from the steam mopping nozzle.
- Remove the mopping pads from the holders in the lower part of the nozzle.
- Remove the water tank from the nozzle.
- Release the cap and pour out the remaining water from the tank. Leave the cap open so that the tank can dry.
- Wipe the steam mopping nozzle, especially the suction opening, with a soft sponge slightly moistened in warm water. Wipe with a dry cloth.

Cleaning the mopping nozzle (SVC 9476BK model only)

- Remove the telescopic tube from the mopping nozzle.
- Remove the mopping pads from the holders in the lower part of the nozzle.
- Release the cap and pour out the remaining water from the tank. Leave the cap open so that the tank can dry.
- Wipe the mopping nozzle, especially the suction opening, with a soft sponge slightly moistened in warm water. Wipe with a dry cloth.

Cleaning the mopping pads

- Wash the mopping pads by hand in warm water (max. 40 °C) with a little detergent for delicate laundry. Wring out and rinse in clean water. Allow to dry.



Warning:

Do not wash the mopping pads in a washing machine or dishwasher, nor dry them in a tumble dryer.



Note:

The mopping pads need to be replaced from time to time. Check their condition regularly and replace them after 6–12 months or as needed.

Cleaning the mattress and upholstery nozzle

- Turn the lock on the side of the nozzle towards the open lock symbol to release the rotating brush.
- Pull the rotating brush out of the brush nozzle.
- Remove hair and fur entangled in the brush. You can use scissors, for example, to release or remove them.
- Wipe the mattress and upholstery nozzle, especially the suction opening, with a soft sponge slightly moistened in warm water. Wipe with a dry cloth.

- Insert the rotating brush back into the nozzle. Press lightly until you feel resistance, and turn the lock towards the closed lock symbol.

Cleaning the motor unit, accessories and holder

- Remove the battery from the motor unit.
- Wipe the motor unit and other accessory parts including the holder with a dry cloth.

Replacing the dust bag

- If a short beep sounds after pressing the ON/OFF button and the ON/OFF button flashes red, the dust bag is full and needs to be replaced.
- Disconnect the mains cable from the mains socket and remove the vacuum cleaner from the collection station.
- Grasp the outer cover with both hands and carefully remove it – see figure **I1**. Place to the side.
- Press the lock at the top of the dust bag cover to release the cover and be able to remove it – see figure **I2**.
- Remove the dust bag – see figure **I3**, and install a new dust bag in the space. Dispose of the full dust bag in mixed waste.
- Install the dust bag cover by first inserting the lower part into the body of the collection station, and then carefully close the upper part until you hear a click.
- Install the outer cover so that the projections on both sides of the outer cover fit into the space in the housing of the collection station.

Cleaning the collection station filter

- Regularly clean the collection station filter, which is located under the dust bag.
- Disconnect the mains cable from the mains socket and remove the vacuum cleaner from the collection station.
- Grasp the outer cover with both hands and carefully remove it – see figure **I1**. Place to the side.
- Press the lock at the top of the dust bag cover to release the cover and be able to remove it – see figure **I2**.
- Remove the dust bag – see figure **I3**, and remove the collection station filter – see figure **I4**.
- Remove dirt from the filter. If necessary, you can rinse it under running water. And then wipe dry with a clean cloth.
- Insert the clean and dry filter back into the collection station. Insert the dust bag, dust bag cover and outer cover.



Warning:

Never install the filter if it is wet or damp. Before installing it, ensure that it is properly dry.



Note:

If the collection station's power decreases when emptying the dust container, the filter is clogged and needs to be cleaned.

RECOMMENDED MAINTENANCE AND REPLACEMENT OF ACCESSORIES

Vacuum Cleaner Part	Recommended Maintenance	Recommended Replacement
Dry vacuuming nozzle	After each use	—
Rotating brush of dry vacuuming nozzle	After each use	Replacement in case of wear or damage
Dust container	After each use	—
HEPA filter and outlet HEPA filter	After each use	Replacement every 3–6 months
Mopping nozzle	After each use	—
Water tank	After each use	—
Mopping pads	After each use	Replacement in case of wear or damage
Mattress and upholstery nozzle	After each use	—
Rotating brush, mattress and upholstery nozzle	After each use	Replacement in case of wear or damage
Other accessories (telescopic tube, nozzle with retractable soft brush, long crevice nozzle, accessory holder)	After each use	Replacement in case of wear or damage
Collection station	Once a month	—
Dust bag	—	Replace when full bag warning appears
Dust bag filter	Once a month	Replacement in case of wear or damage



Note:

The above values are indicative only and may vary depending on the frequency of vacuum cleaner use.

LONG-TERM STORAGE

- If you will not be using the vacuum cleaner for a long time, clean it according to the instructions above and ensure that it is completely dry. Disconnect the collection station from the mains socket. Store the vacuum cleaner with all its accessories in a dry, clean and cool place.
- We recommend charging the battery every 3 months to extend its lifespan.

TROUBLESHOOTING

PROBLEM	CAUSE	SOLUTION
The vacuum cleaner cannot be switched on and controlled.	The battery is depleted.	Allow the battery to fully charge.
	The dust container is full.	Empty the dust container.
	You are using the vacuum cleaner for too long.	Let it cool down.
The suction output is weak.	The outlet HEPA filter is dirty.	Clean the outlet HEPA filter.
	The rotating brush is blocked.	Clean the rotating brush.
	The suction opening or tube is blocked.	Remove the cause of the blockage.
The rotating brush of the dry vacuuming nozzle does not work.	The rotating brush is blocked by tangled hair and fur.	Clean the rotating brush.
The castors of the dry vacuuming nozzle do not rotate.	The castors are blocked by tangled hair and fur.	Remove the tangled hair and fur.
The mopping nozzle does not discharge water, mopping pads are dry.	There is no water in the tank.	Fill the tank with clean water.
The collection station's suction power is low.	The dust bag is full.	Replace the dust bag.
	The dust bag filter is clogged.	Clean the dust bag filter.
The collection station does not work.	The mains cable is not plugged into the mains socket.	Insert the mains cable plug into the mains socket.
	The dust bag is not installed.	Insert the dust bag.
The collection station does not charge the vacuum cleaner.	The mains cable is not plugged into the mains socket.	Insert the mains cable plug into the mains socket.
	The vacuum cleaner is not correctly inserted.	Insert the vacuum cleaner into the opening in the collection station so that the contacts connect.
	The dust container emptying process is in progress.	During the emptying process, charging is interrupted. When the process is complete, charging of the vacuum cleaner will resume.

PROBLEM	CAUSE	SOLUTION
Charging indicators flash red.	Internal temperature is too high. The vacuum cleaner will start but will switch off immediately.	Allow the vacuum cleaner to cool down.
	Liquid has been sucked up.	Switch off the vacuum cleaner, remove the battery, disassemble the vacuum cleaner and dry the liquid with a dry cloth. Allow all parts to dry properly.
	The motor unit/rotating brush has become blocked by a foreign object.	Remove the cause of the blockage.
	The battery is almost flat.	Allow it to charge.



Note:

If the problem persists, switch off the vacuum cleaner and contact an authorised service centre.

INSTRUCTIONS AND INFORMATION ON DISPOSAL OF USED PACKAGING MATERIAL

Dispose of used packaging material at the designated municipal waste disposal site.

DISPOSAL OF USED ELECTRICAL AND ELECTRONIC EQUIPMENT

Used electrical and electronic products must not be disposed of in ordinary municipal waste. To enable the proper disposal, renewal and recycling of these products, deliver them to the designated collection points. Alternatively, in some European Union states or other European countries the products can be returned to the local retailer when buying an equivalent new product. By disposing of this product correctly, you help to conserve valuable natural resources and prevent any potential adverse impact on the environment and human health that could result from improper waste disposal. For more details, contact your local authority or nearest collection point. Fines may be imposed for the improper disposal of this type of waste as per national regulations.

For business entities in European Union States

If you wish to dispose of electrical and electronic equipment, please request the necessary information from your retailer or supplier.

Disposal in other countries outside the European Union

To dispose of this product elsewhere, request the necessary information on the correct disposal method from local authorities or your retailer.

TECHNICAL SPECIFICATIONS

Vacuum cleaner

- Operating voltage.....25.9 V
- Rated power input (vacuum cleaner with dry vacuuming nozzle)....500 W
- Rated power input (steam mopping nozzle) .200 W (160 W after 1 minute)
- Rated power input (mopping nozzle).....20 W
- Rated power input (mattress and upholstery nozzle)15 W
- Battery.....Li-ion / 25.9 V / 3000 mAh
- Weight (motor unit only).....11 kg
- Charging time approximately.....3.5–4 hours
- Water tank capacity (steam mopping nozzle).....170 ml
- Water tank capacity (mopping nozzle)135 ml
- Noise level.....≤85 dB(A)
- Suction power.....≥25 kPa
- Operating time (dry vacuuming nozzle)55–60 minutes (Eco mode)
16–20 minutes (Power mode)
- Operating time (steam mopping nozzle)22–26 minutes (steam mode only)
15–17 minutes (steam mode + Eco mode)
- Operating time (mopping nozzle).....25–29 minutes (Eco mode)

Collection station

- Rated voltage.....220–240 V~
- Rated frequency.....50/60Hz
- Rated power input.....650 W
- Noise level.....≤80 dB(A)
- Suction power.....≥16.5 kPa
- Dimensions280 × 280 × 750 mm
- Weight3.5 kg
- Dust bag capacity2.5 l

Power Adapter

- Input voltage100–240 V~ 50/60 0.6 A
- Output voltage.....30 V = 0.8 A 24.0 W

Original Consumable Accessories Available for Purchase

Replacement battery	SVX 085
Filter set	SVX 086HF
Bag set (5 pcs) for station with filter (1 pc)	SVCX 5051
Mopping pad set (3 pairs)	SVX 087

Changes to text and technical parameters are reserved.

