

OPERATOR'S MANUAL

CRAFTSMAN[®]

7-1/4 in. CIRCULAR SAW WITH LASER GUIDE DOUBLE INSULATED

Model No.
315.108620

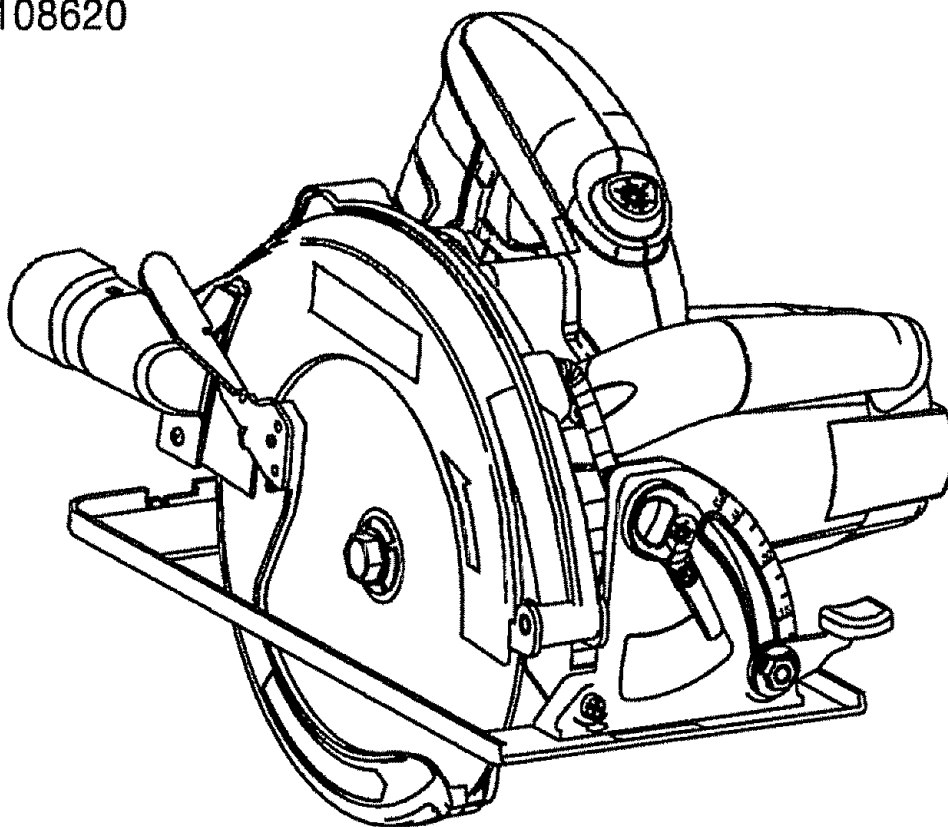

⚠ WARNING: To reduce the risk of injury, the user must read and understand the operator's manual before using this product.

Customer Help Line: 1-800-932-3188

Sears, Roebuck and Co., 3333 Beverly Rd., Hoffman Estates, IL 60179 USA
Visit the Craftsman web page: www.sears.com/craftsman

983000-817
9-05 (REV:01)

Save this manual for future reference



TABLE OF CONTENTS

■ Warranty	2
■ Introduction	2
■ General Safety Rules.....	3-4
■ Specific Safety Rules.....	4-5
■ Symbols.....	6-7
■ Electrical	8
■ Features.....	9-10
■ Assembly.....	10-12
■ Operation.....	13-20
■ Adjustments.....	21
■ Maintenance.....	22
■ Exploded View and Parts List.....	23-24
■ Parts Ordering/Service	Back Page

WARRANTY

ONE-YEAR FULL WARRANTY ON CRAFTSMAN TOOL

If this Craftsman tool fails to give complete satisfaction within one year from date of purchase, **RETURN IT TO ANY SEARS STORE OR PARTS AND REPAIR CENTER OR OTHER CRAFTSMAN OUTLET IN THE UNITED STATES FOR FREE REPAIR.**

If this Craftsman tool is used for commercial or rental purposes, this warranty applies for only 90 days from the date of purchase.

This warranty gives you specific legal rights, and you may also have other rights which vary from state to state.

Sears, Roebuck and Co., Dept. 817WA, Hoffman Estates, IL 60179

INTRODUCTION

This tool has many features for making its use more pleasant and enjoyable. Safety, performance, and dependability have been given top priority in the design of this product making it easy to maintain and operate.

GENERAL SAFETY RULES

⚠ WARNING! Read and understand all instructions. Failure to follow all instructions listed below, may result in electric shock, fire and/or serious personal injury.

SAVE THESE INSTRUCTIONS

WORK AREA

- **Keep your work area clean and well lit.** Cluttered benches and dark areas invite accidents.
- **Do not operate power tools in explosive atmospheres, such as in the presence of flammable liquids, gases, or dust.** Power tools create sparks which may ignite the dust or fumes.
- **Keep bystanders, children, and visitors away while operating a power tool.** Distractions can cause you to lose control.

ELECTRICAL SAFETY

- **Double insulated tools are equipped with a polarized plug (one blade is wider than the other). This plug will fit in a polarized outlet only one way. If the plug does not fit fully in the outlet, reverse the plug. If it still does not fit, contact a qualified electrician to install a polarized outlet. Do not change the plug in any way.** Double Insulation  eliminates the need for the three-wire grounded power cord and grounded power supply system.
- **Avoid body contact with grounded surfaces such as pipes, radiators, ranges and refrigerators.** There is an increased risk of electric shock if your body is grounded.
- **Don't expose power tools to rain or wet conditions.** Water entering a power tool will increase the risk of electric shock.
- **Do not abuse the cord. Never use the cord to carry the tools or pull the plug from an outlet. Keep cord away from heat, oil, sharp edges or moving parts. Replace damaged cords immediately.** Damaged cords increase the risk of electric shock.
- **When operating a power tool outside, use an outdoor extension cord marked "W-A" or "W".** These cords are rated for outdoor use and reduce the risk of electric shock.

PERSONAL SAFETY

- **Stay alert, watch what you are doing and use common sense when operating a power tool. Do not use tool while tired or under the influence of drugs, alcohol, or medication.** A moment of inattention while operating power tools may result in serious personal injury.
- **Dress properly. Do not wear loose clothing or jewelry. Contain long hair. Keep your hair, clothing, and gloves away from moving parts.** Loose clothes, jewelry, or long hair can be caught in moving parts.
- **Avoid accidental starting. Be sure switch is off**

before plugging in. Carrying tools with your finger on the switch or plugging in tools that have the switch on invites accidents.

- **Remove adjusting keys or wrenches before turning the tool on.** A wrench or a key that is left attached to a rotating part of the tool may result in personal injury.
- **Do not overreach. Keep proper footing and balance at all times.** Proper footing and balance enables better control of the tool in unexpected situations.
- **Use safety equipment. Always wear eye protection.** Dust mask, non-skid safety shoes, hard hat, or hearing protection must be used for appropriate conditions.
- **Do not wear loose clothing or jewelry. Contain long hair.** Loose clothes, jewelry, or long hair can be drawn into air vents.
- **Do not use on a ladder or unstable support.** Stable footing on a solid surface enables better control of the tool in unexpected situations.

TOOL USE AND CARE

- **Use clamps or other practical way to secure and support the workpiece to a stable platform.** Holding the work by hand or against your body is unstable and may lead to loss of control.
- **Do not force tool. Use the correct tool for your application.** The correct tool will do the job better and safer at the rate for which it is designed.
- **Do not use tool if switch does not turn it on or off.** Any tool that cannot be controlled with the switch is dangerous and must be repaired.
- **Disconnect the plug from power source before making any adjustments, changing accessories, or storing the tool.** Such preventive safety measures reduce the risk of starting the tool accidentally.
- **Store idle tools out of reach of children and other untrained persons.** Tools are dangerous in the hands of untrained users.
- **Maintain tools with care. Keep cutting tools sharp and clean.** Properly maintained tools with sharp cutting edges are less likely to bind and are easier to control.
- **Check for misalignment or binding of moving parts, breakage of parts, and any other condition that may affect the tool's operation. If damaged, have the tool serviced before using.** Many accidents are caused by poorly maintained tools.
- **Use only accessories that are recommended by the manufacturer for your model.** Accessories that may be suitable for one tool, may become hazardous when used on another tool.
- **Keep the tool and its handle dry, clean and free from oil and grease.** Always use a clean cloth when cleaning. Never use brake fluids, gasoline, petroleum-based products, or any strong solvents to clean your tool. Following this rule will reduce the risk of loss of control and deterioration of the enclosure plastic.

GENERAL SAFETY RULES

SERVICE

- **Tool service must be performed only by qualified repair personnel.** Service or maintenance performed by unqualified personnel could result in a risk of injury.
- **When servicing a tool, use only identical replacement parts. Follow instructions in the Maintenance section of this manual.** Use of unauthorized parts or failure to follow Maintenance Instructions may create a risk of electric shock or injury.

SPECIFIC SAFETY RULES

- **DANGER! Keep hands away from cutting area and blade. Keep your second hand on auxiliary handle or motor housing.** If both hands are holding the saw, they cannot be cut by the blade.
 - **Keep your body positioned to either side of the saw blade, but not in line with the saw blade.** Kickback could cause the saw to jump backwards. (See "Causes And Operator Prevention of Kickback" later.)
 - **Do not reach underneath the work.** The guard cannot protect you from the blade below the work.
 - **Check lower guard for proper closing before each use. Do not operate saw if lower guard does not move freely and close instantly. Never clamp or tie the lower guard into the open position.** If saw is accidentally dropped, lower guard may be bent. Raise the lower guard with the retracting handle and make sure it moves freely and does not touch the blade or any other part, in all angles and depths of cut.
 - **Check the operation and condition of the lower guard spring. If the guard and the spring are not operating properly, they must be serviced before use.** Lower guard may operate sluggishly due to damaged parts, gummy deposits, or a buildup of debris.
 - **Lower guard should be retracted manually only for special cuts, such as "Pocket Cuts" and "Compound Cuts."** Raise lower guard by retracting handle. As soon as blade enters the material, lower guard must be released. For all other sawing, the lower guard should operate automatically.
 - **Always observe that the lower guard is covering the blade before placing saw down on bench or floor.** An unprotected, coasting blade will cause the saw to walk backwards, cutting whatever is in its path. Be aware of the time it takes for the blade to stop after switch is released.
 - **NEVER hold piece being cut in your hands or across your leg.** It is important to support the work properly to minimize body exposure, blade binding, or loss of control.
 - **Hold tool by insulated gripping surfaces when performing an operation where the cutting tool may contact hidden wiring or its own cord.** Contact with a "live" wire will make exposed metal parts of the tool "live" and shock the operator.
 - **When ripping, always use a rip fence or straight edge guide.** This improves the accuracy of the cut and reduces the chance for blade binding.
 - **Always use blades with correct size and shape (diamond vs. round) arbor holes.** Blades that do not match the mounting hardware of the saw will run eccentrically, causing loss of control.
 - **Never use damaged or incorrect blade washers or bolts.** The blade washers and bolts were specially designed for the saw for optimum performance and safety of operation.
- Causes and Operator Prevention of Kickback:**
- Kickback is a sudden reaction to a pinched, bound, or misaligned saw blade, causing an uncontrolled saw to lift up and out of the workpiece toward operator.
- When the blade is pinched or bound tightly by the kerf closing down, the blade stalls and the motor reaction drives the unit rapidly back toward the operator.
- If the blade becomes twisted or misaligned in the cut, the teeth at the back edge of the blade can dig into the top surface of the wood causing the blade to climb out of the kerf and jump back toward the operator.
- Kickback is the result of tool misuse and/or incorrect operating procedures or conditions and can be avoided by taking proper precautions, as given below:
- **Maintain a firm grip with both hands on the saw and position your body and arm to allow you to resist kickback forces.** Kickback forces can be controlled by the operator, if proper precautions are taken.
 - **When blade is binding, or when interrupting a cut for any reason, release the trigger and hold the saw motionless in the material until the blade comes to a complete stop. Never attempt to remove the saw from the work or pull the saw backward while the blade is in motion, or KICKBACK may occur.** Investigate and take corrective actions to eliminate the cause of blade binding.
 - **When restarting a saw in the workpiece, center the saw blade in the kerf and check that saw teeth are not engaged into the material.** If saw blade is binding, it may walk up or KICKBACK from the workpiece as the saw is restarted.
 - **Support large panels to minimize the risk of blade pinching and KICKBACK.** Large panels tend to sag under their own weight. Supports must be placed under the panel on both sides, near the line of cut and near the edge of the panel.

SPECIFIC SAFETY RULES

- **Do not use dull or damaged blade.** Unsharpened or improperly set blades produce narrow kerf which causes excessive friction, blade binding and KICKBACK.
- **Blade depth and bevel adjusting locking levers must be tight and secure before making cut.** If blade adjustment shifts while cutting, it may cause binding and KICKBACK.
- **Use extra caution when making a "Pocket Cut" into existing walls or other blind areas.** The protruding blade may cut objects that can cause KICKBACK.
- **Know your power tool.** Read operator's manual carefully. Learn its applications and limitations, as well as the specific potential hazards related to this tool. Following this rule will reduce the risk of electric shock, fire, or serious injury.
- **Always wear safety glasses.** Everyday eyeglasses have only impact-resistant lenses; they are NOT safety glasses. Following this rule will reduce the risk of serious personal injury.
- **Protect your lungs.** Wear a face or dust mask if the operation is dusty. Following this rule will reduce the risk of serious personal injury.
- **Protect your hearing.** Wear hearing protection during extended periods of operation. Following this rule will reduce the risk of serious personal injury.
- **Inspect tool cords periodically and, if damaged, have repaired at your nearest authorized service center. Constantly stay aware of cord location.** Following this rule will reduce the risk of electric shock or fire.
- **Check damaged parts.** Before further use of the tool, a guard or other part that is damaged should be carefully checked to determine that it will operate properly and perform its intended function. Check for alignment of moving parts, binding of moving parts, breakage of parts, mounting, and any other conditions that may affect its operation. A guard or other part that is damaged should be properly repaired or replaced by an authorized service center. Following this rule will reduce the risk of shock, fire, or serious injury.
- **Make sure your extension cord is in good condition.** When using an extension cord, be sure to use one heavy enough to carry the current your product will draw. A wire gage size (A.W.G.) of at least 12 is recommended for an extension cord 50 feet or less in length. A cord exceeding 100 feet is not recommended. If in doubt, use the next heavier gage. The smaller the gage number, the heavier the cord. An undersized cord will cause a drop in line voltage resulting in loss of power and overheating.
- **Inspect for and remove all nails from lumber before using this tool.** Following this rule will reduce the risk of serious personal injury.

Laser Guide Warnings:

The laser guide radiation used in the Craftsman circular saw is Class IIIa with maximum 5mW and 650nm wavelengths. These lasers do not normally present an optical hazard although staring at the beam may cause flash blindness.

- **Avoid direct eye exposure** when using the laser guide.
- The laser shall be used and maintained in accordance with the manufacturer's instructions.
- Never aim the beam at a person or object other than the workpiece.
- Always ensure the laser beam is aimed at a sturdy workpiece without reflective surfaces. Shiny reflective sheet metal or similar shiny materials are not suitable for laser use.
- All repairs should be made by an authorized service representative or the laser manufacturer.
- **Save these instructions.** Refer to them frequently and use them to instruct others who may use this tool. If you loan someone this tool, loan them these instructions also.











⚠ WARNING: Some dust created by power sanding, sawing, grinding, drilling, and other construction activities contains chemicals known to cause cancer, birth defects or other reproductive harm. Some examples of these chemicals are:

- lead from lead-based paints,
- crystalline silica from bricks and cement and other masonry products, and
- arsenic and chromium from chemically-treated lumber.

Your risk from these exposures varies, depending on how often you do this type of work. To reduce your exposure to these chemicals: work in a well ventilated area, and work with approved safety equipment, such as those dust masks that are specially designed to filter out microscopic particles.



SYMBOLS

Some of the following symbols may be used on this tool. Please study them and learn their meaning. Proper interpretation of these symbols will allow you to operate the tool better and safer.

SYMBOL	NAME	DESIGNATION/EXPLANATION
V	Volts	Voltage
A	Amperes	Current
Hz	Hertz	Frequency (cycles per second)
W	Watt	Power
min	Minutes	Time
~	Alternating Current	Type of current
=	Direct Current	Type or a characteristic of current
n_0	No Load Speed	Rotational speed, at no load
	Class II Construction	Double-insulated construction
.../min	Per Minute	Revolutions, strokes, surface speed, orbits etc., per minute
	Wet Conditions Alert	Do not expose to rain or use in damp locations.
	Read The Operator's Manual	To reduce the risk of injury, user must read and understand operator's manual before using this product.
	Eye Protection	Always wear safety goggles, safety glasses with side shields, or a full face shield when operating this product.
	Safety Alert	Precautions that involve your safety.
	No Hands Symbol	Failure to keep your hands away from the blade will result in serious personal injury.
	No Hands Symbol	Failure to keep your hands away from the blade will result in serious personal injury.
	No Hands Symbol	Failure to keep your hands away from the blade will result in serious personal injury.
	No Hands Symbol	Failure to keep your hands away from the blade will result in serious personal injury.
	Hot Surface	To reduce the risk of injury or damage, avoid contact with any hot surface.

SYMBOLS

The following signal words and meanings are intended to explain the levels of risk associated with this product.

SYMBOL	SIGNAL	MEANING
	DANGER:	Indicates an imminently hazardous situation, which, if not avoided, will result in death or serious injury.
	WARNING:	Indicates a potentially hazardous situation, which, if not avoided, could result in death or serious injury.
	CAUTION:	Indicates a potentially hazardous situation, which, if not avoided, may result in minor or moderate injury.
	CAUTION:	(Without Safety Alert Symbol) Indicates a situation that may result in property damage.

SERVICE

Service requires extreme care and knowledge and should be performed only by a qualified service technician. For service we suggest you return the product to your nearest **AUTHORIZED SERVICE CENTER** for repair. When servicing, use only identical replacement parts.



WARNING: To avoid serious personal injury, do not attempt to use this product until you read thoroughly and understand completely the operator's manual. Save this operator's manual and review frequently for continuing safe operation and instructing others who may use this product.



WARNING:



The operation of any power tool can result in foreign objects being thrown into your eyes, which can result in severe eye damage. Before beginning power tool operation, always wear safety goggles, safety glasses with side shields, or a full face shield when needed. We recommend Wide Vision Safety Mask for use over eyeglasses or standard safety glasses with side shields. Always use eye protection which is marked to comply with ANSI Z87.1.

SAVE THESE INSTRUCTIONS

ELECTRICAL

DOUBLE INSULATION

Double Insulation is a concept in safety in electric power tools, which eliminates the need for the usual three-wire grounded power cord. All exposed metal parts are isolated from the internal metal motor components with protecting insulation. Double insulated tools do not need to be grounded.

⚠ WARNING: The double insulated system is intended to protect the user from shock resulting from a break in the tool's internal insulation. Observe all normal safety precautions to avoid electrical shock.

NOTE: Servicing of a tool with double insulation requires extreme care and knowledge of the system and should be performed only by a qualified service technician. For service, we suggest you return the tool to your nearest authorized service center for repair. Always use original factory replacement parts when servicing.

ELECTRICAL CONNECTION

This tool has a precision-built electric motor. It should be connected to a **power supply that is 120 volts, 60 Hz, AC only (normal household current)**. Do not operate this tool on direct current (DC). A substantial voltage drop will cause a loss of power and the motor will overheat. If your tool does not operate when plugged into an outlet, double-check the power supply.

EXTENSION CORDS

When using a power tool at a considerable distance from a power source, be sure to use an extension cord that has the capacity to handle the current the tool will draw. An undersized cord will cause a drop in line voltage, resulting in overheating and loss of power. Use the chart to determine the minimum wire size required in an extension cord. Only round jacketed cords listed by Underwriter's Laboratories (UL) should be used.

When working outdoors with a tool, use an extension cord that is designed for outside use. This type of cord is designated with "WA" on the cord's jacket.

Before using any extension cord, inspect it for loose or exposed wires and cut or worn insulation.

**Ampere rating (on tool faceplate)
0-2.0 2.1-3.4 3.5-5.0 5.1-7.0 7.1-12.0 12.1-16.0

Cord Length	Wire Size (A.W.G.)					
	16	16	16	16	14	14
25'	16	16	16	16	14	14
50'	16	16	16	14	14	12
100'	16	16	14	12	10	—

**Used on 12 gauge - 20 amp circuit
NOTE: AWG = American Wire Gauge

⚠ WARNING: Keep the extension cord clear of the working area. Position the cord so that it will not get caught on lumber, tools or other obstructions while you are working with a power tool. Failure to do so can result in serious personal injury.

⚠ WARNING: Check extension cords before each use. If damaged replace immediately. Never use tool with a damaged cord since touching the damaged area could cause electrical shock resulting in serious injury.

FEATURES

PRODUCT SPECIFICATIONS

- Blade Diameter 7-1/4 in.
- Blade Arbor 5/8 in.
- Cutting Depth at 90° 2-3/8 in.
- Cutting Depth at 45° 1-13/16 in.
- Cutting Depth at 51.5° 1-5/8 in.
- Input 120 V, 60 Hz, AC Only, 14 Amps
- No Load Speed 5,000/min.
- Net Weight 11 lbs.
- Laser Guide Class IIa, <5mW max, 650 nm

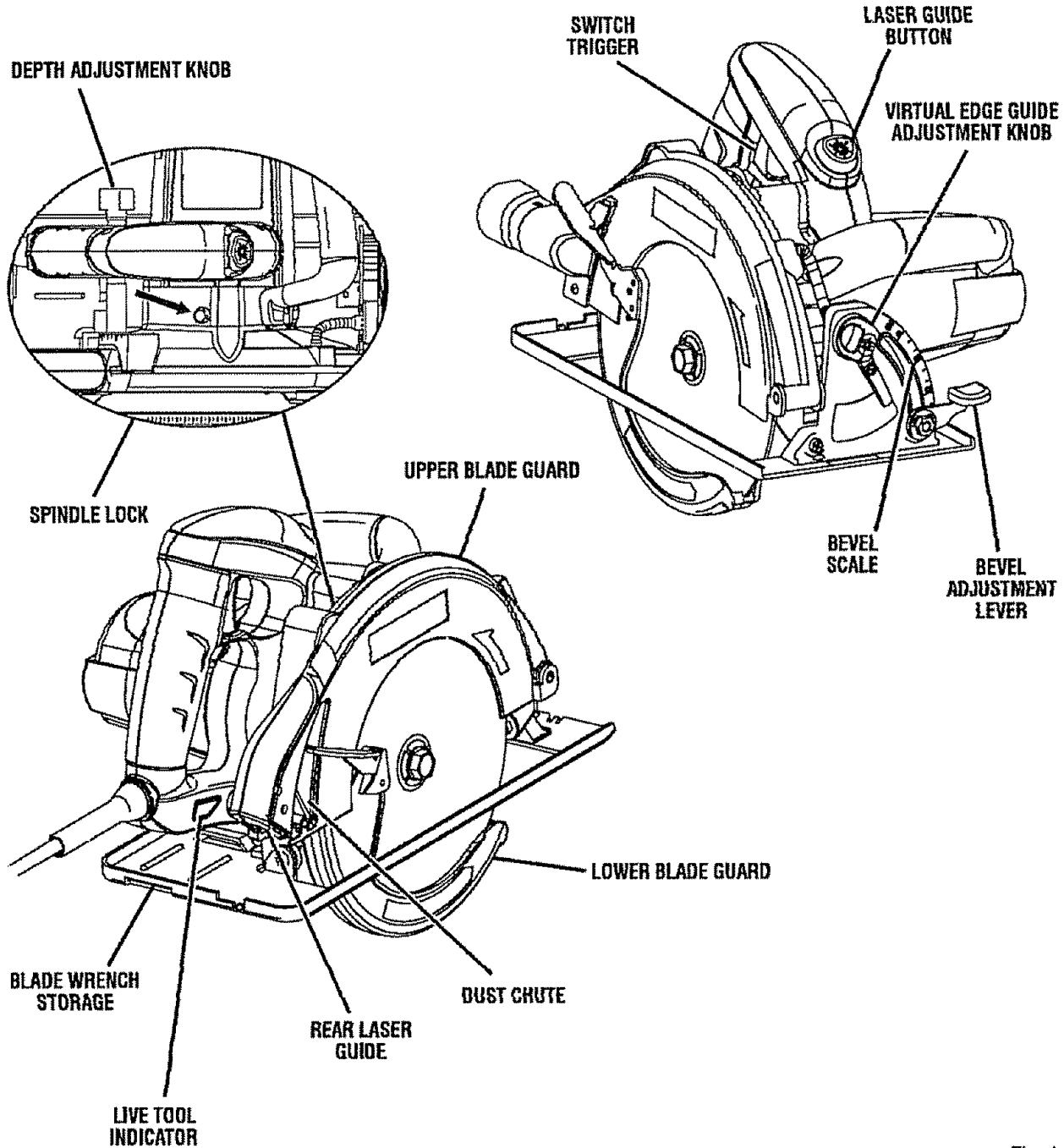

Fig. 1



FEATURES

KNOW YOUR CIRCULAR SAW

See Figure 1.

Before attempting to use this product, familiarize yourself with all operating features and safety rules.

DUST COLLECTION

To direct sawdust and chips away from the operator, a dust chute is located on the side of the upper blade guard. To collect sawdust, a standard vacuum hose can be attached to the dust chute using the adapter and dust nozzle provided.

ERGONOMIC DESIGN

The design of your circular saw provides for maintaining proper two hand control when cutting. It has been designed to be comfortable and easy to grasp.

LASER GUIDES

The saw is equipped with two laser guides, the rear laser guide and the Virtual Edge Guide. The laser guides will generate a red colored laser beam on the work surface in front of and behind the saw when turned on.

LIVE TOOL INDICATOR

The live tool indicator is located on the handle of the saw and indicates that the tool is connected to a power supply.

SPINDLE LOCK

The spindle lock allows you to secure the blade when turning the blade screw.

NOTE: Do not run circular saw with spindle lock engaged.

ASSEMBLY

UNPACKING

This product requires assembly.

- Carefully remove the tool and any accessories from the box. Make sure that all items listed in the packing list are included.
- Inspect the tool carefully to make sure no breakage or damage occurred during shipping.
- Do not discard the packing material until you have carefully inspected and satisfactorily operated the tool.
- If any parts are damaged or missing, please call 1-800-932-3188 for assistance.

PACKING LIST

Circular Saw
7-1/4 in. Blade
Dust Chute Adaptor
Dust Nozzle
Wrench
Case
Operator's Manual



WARNING: If any parts are damaged or missing do not operate this tool until the damaged or missing parts are replaced. Failure to do so could result in possible serious personal injury.



WARNING: Do not attempt to modify this tool or create accessories not recommended for use with this tool. Any such alteration or modification is misuse and could result in a hazardous condition leading to possible serious personal injury.



WARNING: Do not connect to power supply until assembly is complete. Failure to comply could result in accidental starting and possible serious injury.

ASSEMBLY

WARNING: 7-1/4 in. blade is the maximum blade capacity of the saw. Also, never use a blade that is too thick to allow outer blade washer to engage with the flat on the spindle. Larger blades will come in contact with the blade guards, while thicker blades will prevent blade screw from securing blade on spindle. Either of these situations could result in a serious accident.

CAUTION: To prevent damage to the spindle or spindle lock, always allow motor to come to a complete stop before engaging spindle lock.

ATTACHING BLADE

See Figures 2 - 3.

- Unplug the saw.
- Depress spindle lock button.
- Remove blade screw by turning it counterclockwise with the wrench, while keeping the spindle lock button depressed.
- Remove spring washer and outer blade washer ("D" washer).
- Wipe a drop of oil onto the inner flange bushing and outer blade washer ("D" washer) where they contact blade.

WARNING: If inner flange bushing has been removed, replace it before placing blade on spindle. Failure to do so will prevent blade from tightening properly and could result in serious personal injury.

- Retract the lower blade guard into the upper blade guard using the lower blade guard handle. Make sure the lower guard spring works properly, allowing the guard to move freely.
- Check to see that the saw teeth and arrow on the saw blade and the arrow on the lower guard are pointing in the same direction.
NOTE: The saw teeth point upward at the front of the saw as shown.
- Fit the saw blade inside the lower blade guard and onto the spindle.
- Replace "D" washer.
- Replace spring washer with cupped side against "D" washer.
- Depress spindle lock button and replace blade screw.
- Tighten blade screw securely by turning it clockwise with the wrench.

NOTE: Never use a blade that is too thick to allow the "D" washer to engage with the flat on the spindle.

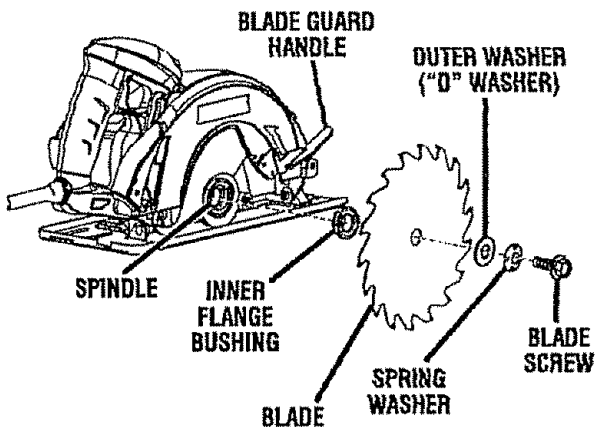

Fig. 2

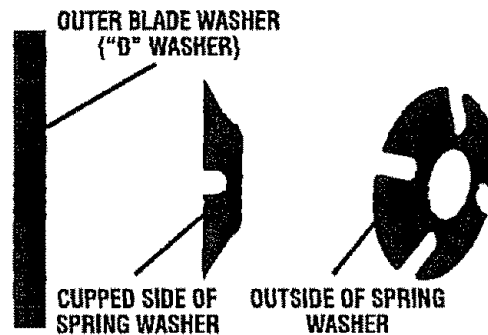

Fig. 3

ASSEMBLY

REMOVING BLADE

See Figure 4.

- Unplug the saw.
- Depress spindle lock button.
- Remove blade screw by turning it counterclockwise with the wrench.
- Remove spring washer and outer blade washer ("D" washer).
- Lift lower blade guard.
- Remove blade.

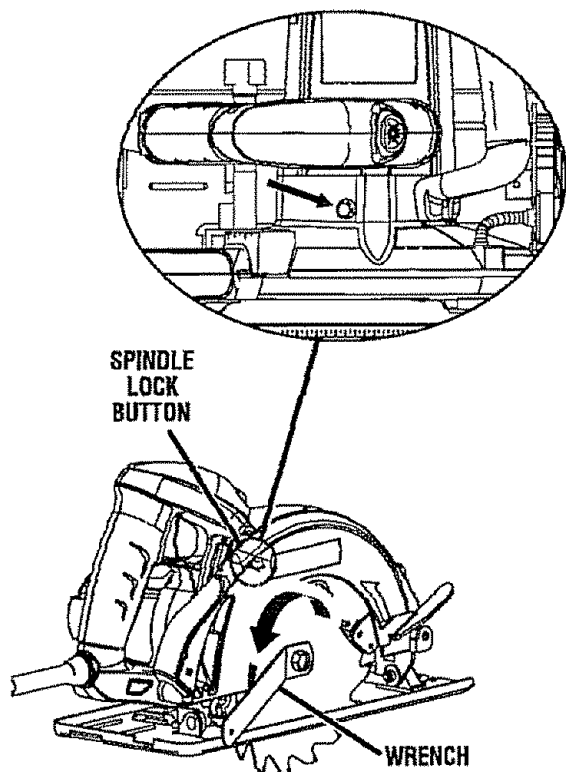

Fig. 4

ATTACHING DUST CHUTE ADAPTER AND DUST NOZZLE

See Figure 5.

NOTE: If you use the dust nozzle, you should always connect it to a standard vacuum hose.

- Unplug the saw.
- Lift lower blade guard.
- Orient adapter to fit into the dust chute opening on upper blade guard.
- Secure adapter with screw provided.
- Align hole in nozzle with raised lip on adapter and snap into place.
- Attach standard vacuum hose to nozzle.

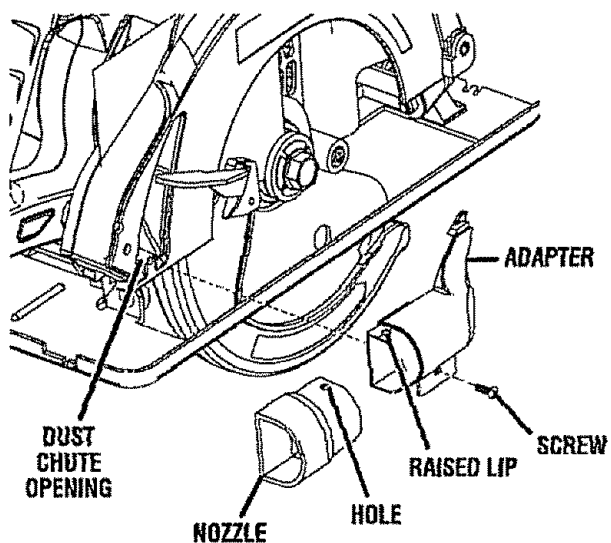

Fig. 5

OPERATION

WARNING: Do not allow familiarity with tools to make you careless. Remember that a careless fraction of a second is sufficient to inflict serious injury.

WARNING: Always wear safety goggles or safety glasses with side shields when operating power tools. Failure to do so could result in objects being thrown into your eyes resulting in possible serious injury.

WARNING: Always unplug the tool when changing operation settings or when the tool is not in use. Failure to unplug the tool may result in accidental starting and serious personal injury.

APPLICATIONS

You may use this tool for the purposes listed below:

- Cross Cutting/Rip Cutting
- Bevel Cutting
- Plunge Cutting

KICKBACK

See Figures 6 - 8.

Kickback occurs when the blade stalls rapidly and the saw is driven back towards you. Blade stalling is caused by any action which pinches the blade in the wood.

DANGER: Release switch immediately if blade binds or saw stalls. Kickback could cause you to lose control of the saw. Loss of control can lead to serious personal injury.

To guard against kickback, avoid dangerous practices such as the following:

- Setting blade depth incorrectly
- Sawing into knots or nails in workpiece
- Twisting the blade while making a cut
- Making a cut with a dull, gummed up, or improperly set blade
- Supporting the workpiece incorrectly
- Forcing a cut
- Cutting warped or wet lumber
- Operating the tool incorrectly or misusing the tool

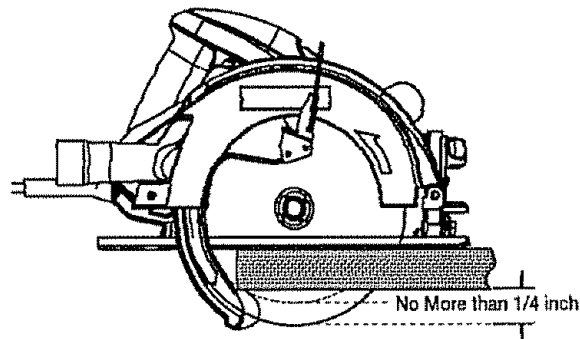

KICKBACK - BLADE SET TOO DEEP

Fig. 6

OPERATION

To lessen the chance of kickback, follow these safety practices.

- Keep the blade at the correct depth setting. The depth setting should not exceed 1/4 in. below the material being cut.
- Inspect the workpiece for knots or nails before cutting. Never saw into a knot or nail.
- Make straight cuts. Always use a guide when rip cutting. This helps prevent twisting the blade.
- Use clean, sharp, and properly set blades. Never make cuts with dull blades.
- Support the workpiece properly before beginning a cut.
- Use steady, even pressure when making a cut. Never force a cut.
- Do not cut warped or wet lumber.
- Hold the saw firmly with both hands and keep your body in a balanced position so as to resist the forces if kickback should occur.

WARNING: When using the saw, always stay alert and exercise control. Do not remove the saw from the workpiece while the blade is moving.

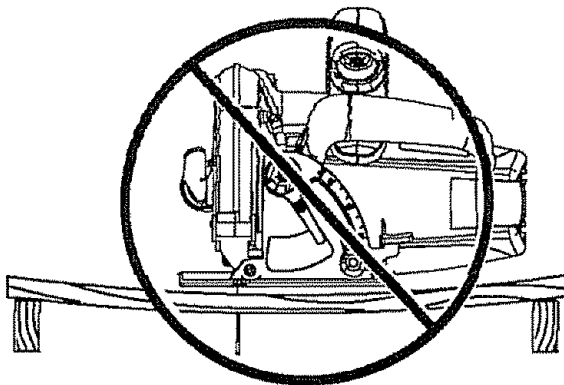

INCORRECT SUPPORT

Fig. 7

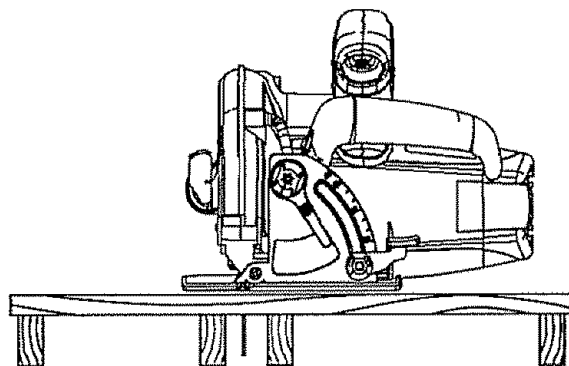

CORRECT SUPPORT

Fig. 8

SAW BLADES

The best of saw blades will not cut efficiently if they are not kept clean, sharp, and properly set. Using a dull blade will place a heavy load on the saw and increase the danger of kickback. Keep extra blades on hand, so that sharp blades are always available.

Gum and wood pitch hardened on blades will slow the saw down. Remove saw blade from the saw and use gum and pitch remover, hot water, or kerosene to remove these accumulations. **DO NOT USE GASOLINE.**

BLADE GUARD SYSTEM

See Figure 9.

The lower blade guard attached to the circular saw is there for your protection and safety. Do not alter it for any reason. If it becomes damaged, do not operate the saw until you have the guard repaired or replaced. Always leave guard in operating position when using the saw.

DANGER: When sawing through work, lower blade guard does not cover blade on the underside of work. Since blade is exposed on underside of work, keep hands and fingers away from cutting area. Any part of your body coming in contact with moving blade will result in serious injury.

CAUTION: Never use saw when guard is not operating correctly. Check the guard for correct operation before each use. The guard is operating correctly when it moves freely and readily returns to the closed position. If you drop the saw, check the lower blade guard and bumper for damage at all depth settings before reuse.

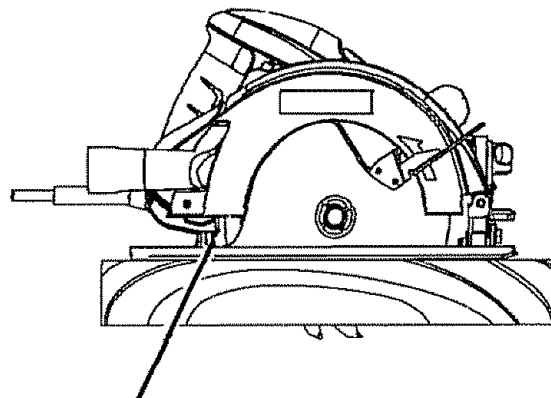

LOWER BLADE GUARD IS IN UP POSITION WHEN MAKING A CUT

Fig. 9

OPERATION

STARTING/STOPPING THE SAW

See Figure 10.

To start the saw: Depress the switch trigger.

Always let the blade reach full speed, then guide the saw into the workpiece.

WARNING: The blade coming in contact with the workpiece before it reaches full speed could cause the saw to “kickback” towards you resulting in serious personal injury.

To stop the saw: Release the switch trigger.

NOTE: Allow the blade to come to a complete stop before removing saw from workpiece.

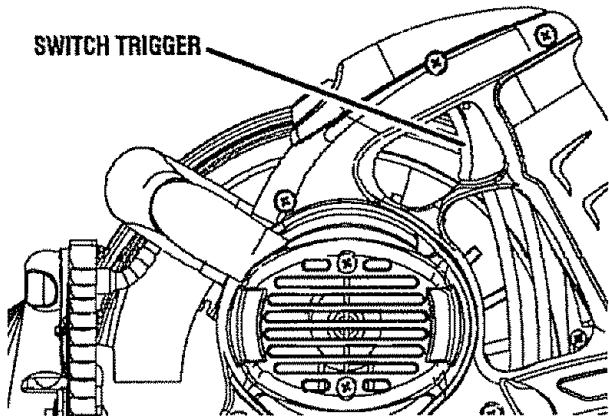

Fig. 10

WARNING: Always unplug the tool when changing operation settings or when the tool is not in use. Failure to unplug the tool may result in accidental starting and serious personal injury.

ADJUSTING BLADE DEPTH

See Figure 11.

Always keep correct blade depth setting. The correct blade depth setting for all cuts should not exceed 1/4 in. below the material being cut. More blade depth will increase the chance of kickback and cause the cut to be rough. For more depth of cut accuracy, a scale is located on the upper blade guard.

- Unplug the saw.
- Loosen depth adjustment knob.
- Determine the desired depth of cut.
- Locate depth of cut scale on back of upper blade guard.
- Hold base flat against the workpiece and raise or lower saw until the indicator mark on bracket aligns with notch on blade guard.
- Tighten depth adjustment knob securely.

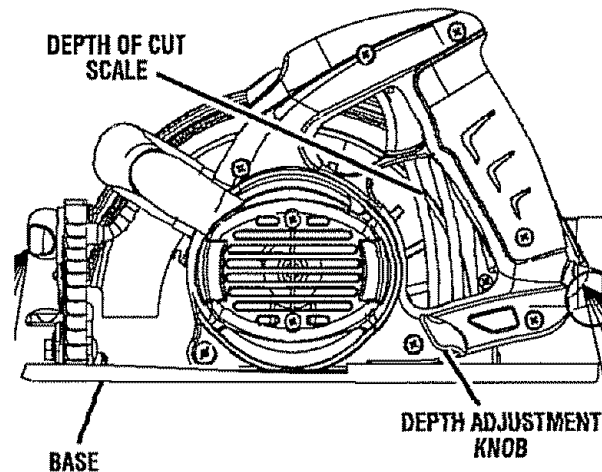

Fig. 11

OPERATION

OPERATING THE SAW

See Figures 12 - 14.

It is important to understand the correct method for operating the saw. Refer to the figures in this section to learn the correct and incorrect ways for handling the saw.

WARNING: To make sawing easier and safer, always maintain proper control of the saw. Loss of control could cause an accident resulting in possible serious personal injury.

DANGER: When lifting the saw from the workpiece, the blade is exposed on the underside of the saw until the lower blade guard closes. Make sure the lower blade guard is closed before setting the saw down.

To make the best possible cut, follow these helpful hints.

- Hold the saw firmly with both hands.
- Avoid placing your hand on the workpiece while making a cut.
- Support the workpiece so that the cut (kerf) is always to your side.
- Support the workpiece near the cut.

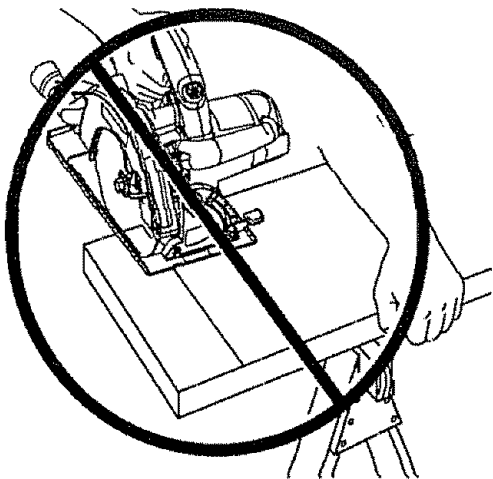

Fig. 12

- Clamp the workpiece securely so that the workpiece will not move during the cut.
- Always place the saw on the workpiece that is supported, not the "cut off" piece.
- Place the workpiece with the "good" side down.

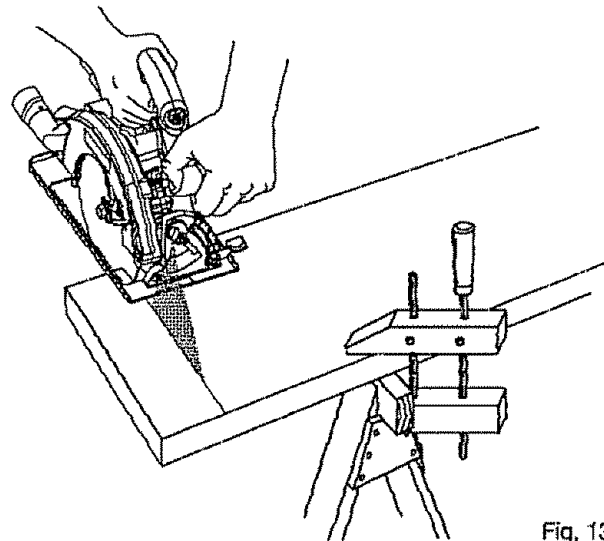

Fig. 13

- Draw a guideline along the desired line of cut before beginning your cut.
- Keep the cord away from the cutting area. Always place the cord to prevent it from hanging up on the workpiece while making a cut.

DANGER: If the cord hangs up on the workpiece during a cut, release the switch trigger immediately. Unplug the saw and reposition the cord to prevent it from hanging up again.

DANGER: Using a saw with a damaged cord could result in serious personal injury or death. If the cord has been damaged, have it replaced before using the saw again.

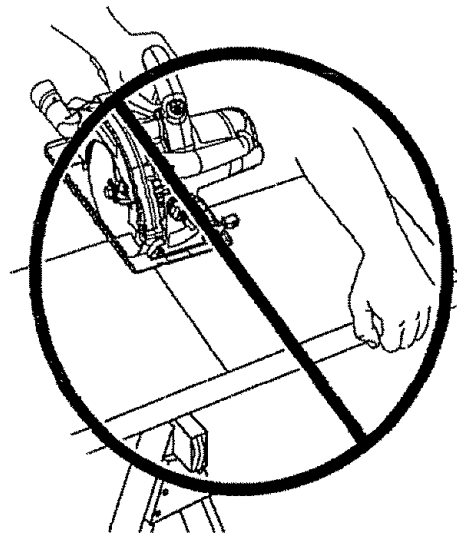

Fig. 14

OPERATION

⚠ WARNING: Do not stare into the laser beams or turn the lasers on when the tool is not in use. Failure to do so could result in possible serious personal injury.

USING THE LASER GUIDES

See Figures 15 - 16.

The laser guides will generate a red colored laser beam on the work surface in front of and behind the saw when turned on. The front laser or Virtual Edge Guide can be adjusted for use as an edge guide with a scale of 0 - 6 in. The rear laser aides in aligning plunge cuts and following the kerf when exiting the workpiece.

NOTE: The laser units come from the factory already installed and aligned. If the rear laser guide becomes misaligned after time, refer to the *Adjustments* section for realignment instructions. The Virtual Edge Guide requires no further alignment.

- Mark the line of cut on the workpiece.
- Push in and turn the Virtual Edge Guide adjustment knob until the needle is aligned to the desired position on the Virtual Edge Guide scale.
- Adjust the depth and angle of the cut as needed.
- Plug the tool into a power supply and press the laser guide button to activate the laser.
- Start the motor.

NOTE: Do not touch the blade to the workpiece until the saw has reached maximum speed.

- Slowly push the saw forward into the workpiece.
- **NOTE:** Keep the laser beam on the marked line on the workpiece for precision cutting.
- Once the cut is complete, allow the saw to come to a complete stop before turning off the laser.
- Unplug the saw.

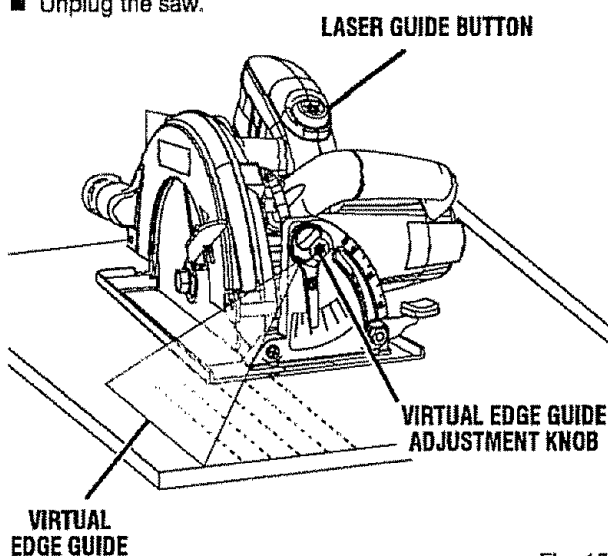
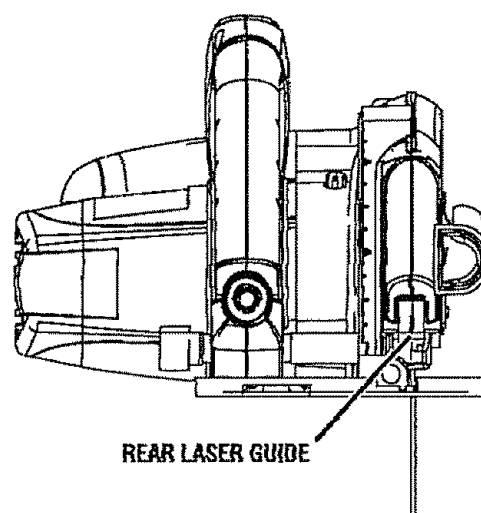
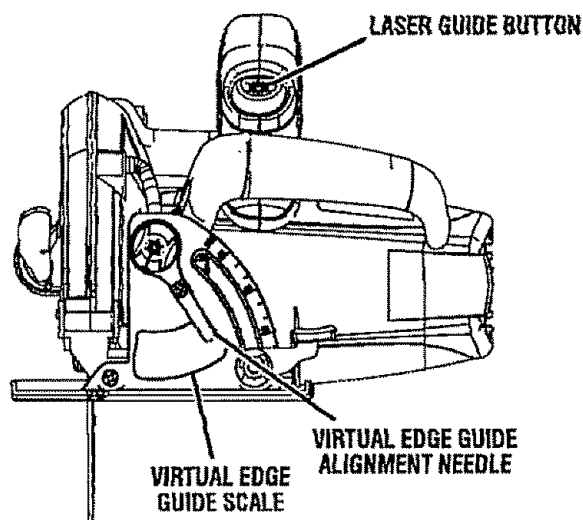

Fig. 16

Fig. 15



OPERATION

CROSS CUTTING/RIP CUTTING

See Figure 17.

When making a cross cut or rip cut, align the line of cut with the outer blade guide notch on the base as shown in the figure.

Since blade thicknesses vary, always make a trial cut in scrap material along a guideline to determine how much, if any, you must offset the guideline to produce an accurate cut.

NOTE: The distance from the line of cut to the guideline is the amount you should offset the guide.

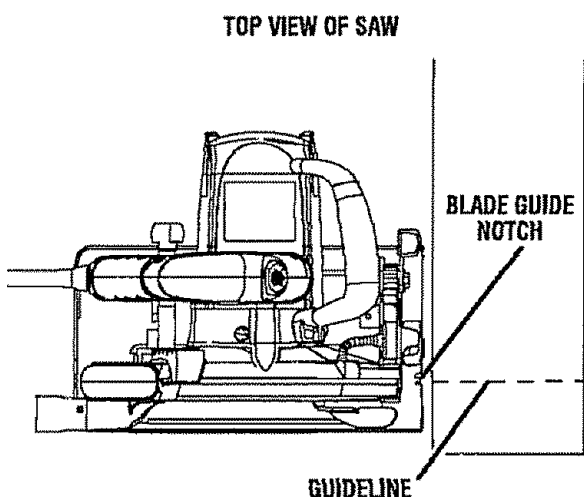

Fig. 17

LENGTH OF CUT SCALE

See Figure 18.

The saw is equipped with a length of cut scale on its base. It is parallel with the saw blade and you can use it to measure the distance into the material the blade cuts.

NOTE: Six inches is the maximum length of cut that you can measure. Also, it is accurate only when the depth of cut is set at full maximum depth.

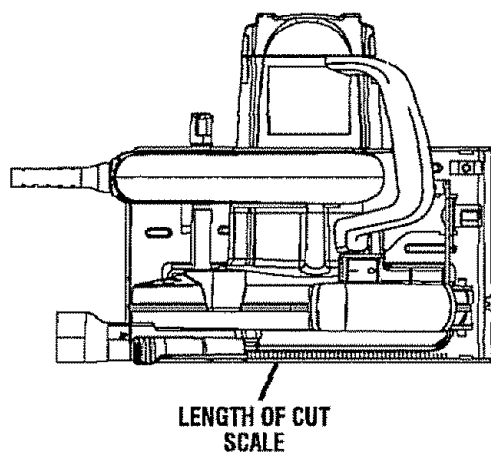

Fig. 18

BEVEL CUTTING

See Figures 19 - 20.

- Align the line of cut with the inner blade guide notch on the base when making 45° bevel cuts.
- Make a trial cut in scrap material along a guideline to determine how much you should offset the guideline on the cutting material.
- Adjust the angle of the cut to any desired setting between zero and 51.5°. Refer to **To Adjust Bevel Setting**.

TO ADJUST BEVEL SETTING

See Figure 19.

- Unplug the circular saw.
- Lift bevel adjustment lever up.
- Raise motor housing end of saw until you reach desired angle setting on bevel scale.
- Lower bevel adjustment lever until motor housing is locked into place.

WARNING: Attempting a bevel cut without having the bevel adjustment lever securely tightened can result in serious personal injury.

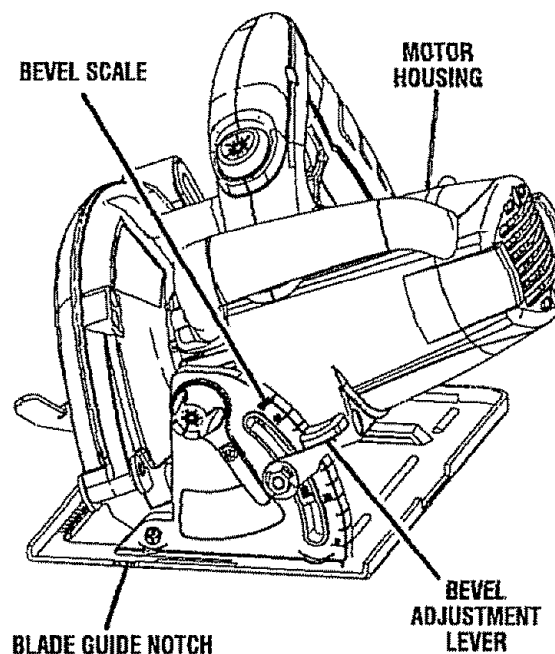

Fig. 19

OPERATION

MAKING A BEVEL CUT

See Figure 20.

- Hold the saw firmly with both hands as shown.
- Rest the front edge of the base on the workpiece.
- Start the saw and let the blade reach full speed.
- Guide the saw into the workpiece and make the cut.
- Release the switch trigger and allow the blade to come to a complete stop.
- Lift the saw from the workpiece.

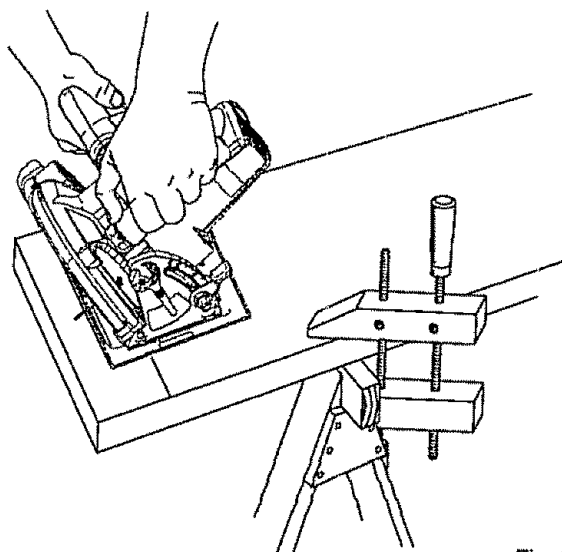

Fig. 20

POSITIVE 0° BEVEL STOP

See Figure 21.

WARNING: Failure to unplug the tool could result in accidental starting causing serious personal injury.

The saw has a positive 0° bevel stop that has been factory adjusted to assure 0° angle of the saw blade when making 90° cuts.

CHECKING POSITIVE 0° BEVEL STOP

- Unplug the circular saw.
- Place the saw in an upside down position on a workbench.
- Check the squareness of the saw blade to the base of the saw using a carpenter's square.

ADJUSTING POSITIVE 0° BEVEL STOP

- Unplug the circular saw.
- Lift bevel adjustment lever up.
- Turn setscrew with hex key and adjust base until it is square with the saw blade.
- Lower bevel adjustment lever until motor housing is locked into place.

WARNING: Attempting a bevel cut without having the bevel adjustment lever securely tightened can result in serious personal injury.

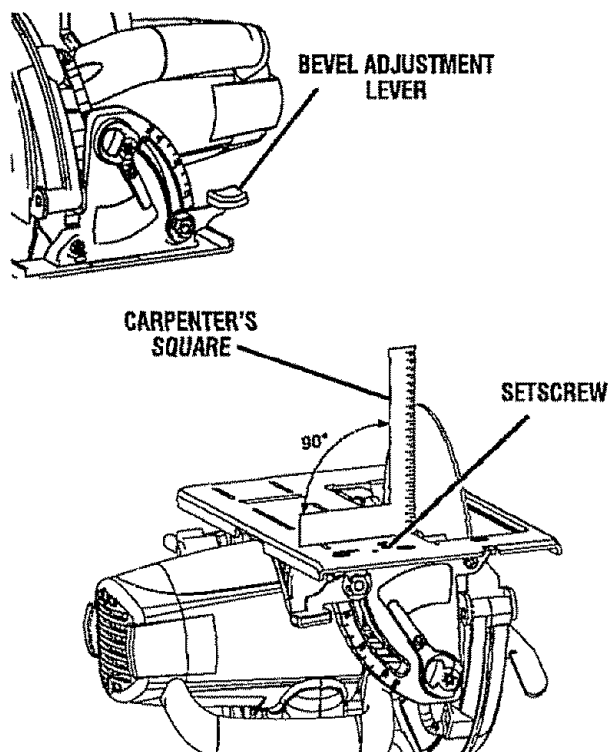

Fig. 21

OPERATION

PLUNGE CUTTING

See Figures 22 - 23.

⚠ WARNING: Always adjust bevel setting to zero before making a plunge cut. Attempting a plunge cut at any other setting can result in loss of control of the saw possibly causing serious personal injury.

- Adjust the bevel setting to zero.
- Set the blade to the correct blade depth setting.
- Swing the lower blade guard up using the lower blade guard handle.
NOTE: Always raise the lower blade guard with the handle to avoid serious personal injury.
- Hold the lower blade guard by the handle.
- Rest the front of the base flat against the workpiece with the rear of the handle raised so the blade does not touch the workpiece.
- Start the saw and let the blade reach full speed.
- Guide the saw into the workpiece and make the cut.

⚠ WARNING: Always cut in a forward direction when plunge cutting. Cutting in the reverse direction could cause the saw to climb up on the workpiece and back toward you.

- Release the switch trigger and allow the blade to come to a complete stop.
- Lift the saw from the workpiece.
- Clear corners out with a hand saw or sabre saw.

⚠ WARNING: Never tie the lower blade guard in a raised position. Leaving the blade exposed could lead to serious personal injury.

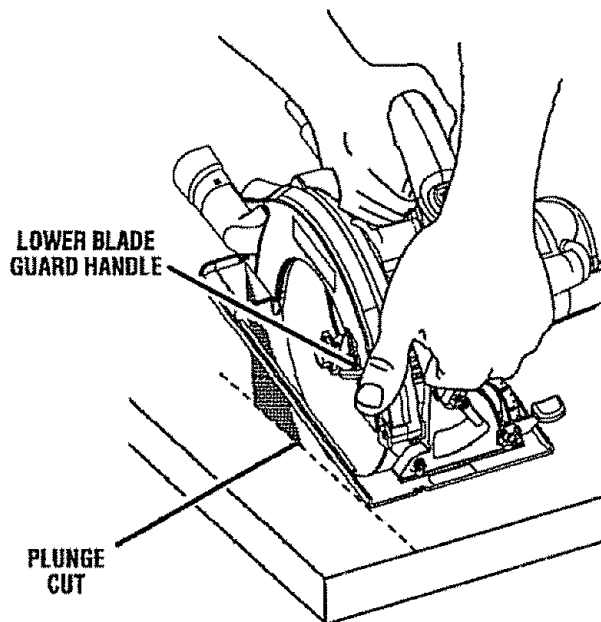

Fig. 22

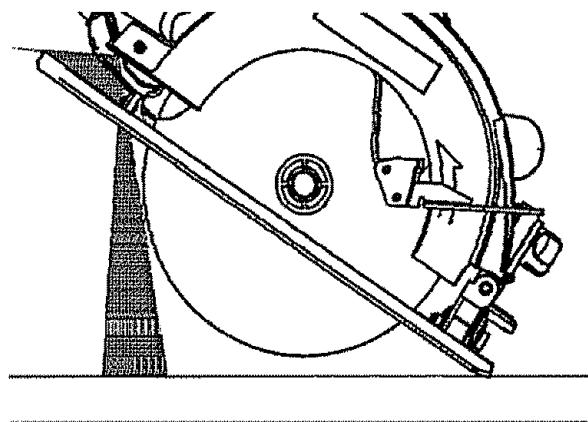

Fig. 23

ADJUSTMENTS

WARNING: Before performing any adjustment, remove blade from saw. Failure to do so could result in possible serious personal injury.

WARNING: DO NOT point the laser at yourself or others. Class IIIa lasers will burn the retinas and could cause serious injury to the eyes.

CAUTION: Use of controls or adjustments or performance other than those specified herein may result in hazardous radiation exposure.

ADJUSTING THE REAR LASER

See Figures 24 - 25.

NOTE: The rear laser is the only laser on the tool designed to be realigned.

The rear laser can be realigned by adjusting the two screws located in the back of the upper blade guard. The top screw moves the laser beam laterally from left to right. The bottom screw moves the laser beam in a rotational direction.

NOTE: Draw a pencil line on scrap workpiece parallel to the long edge of the base as a straight line guide to aid in the adjusting process.

- Remove the blade, dust nozzle, and dust nozzle adaptor if installed.
- Plug in the saw.
- Turn laser on.
- Rest the back of the base on scrap workpiece.
- Adjust screws as necessary.
- Since blade thicknesses vary, always make a trial cut in scrap workpiece to ensure an accurate cut.
- Check for proper alignment.
- Repeat as necessary until laser is aligned.

REMOVE DUST KNOZZLE AND ADAPTOR

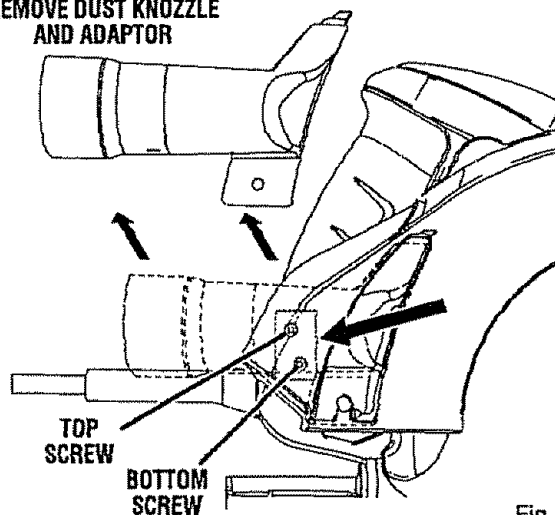

Fig. 24

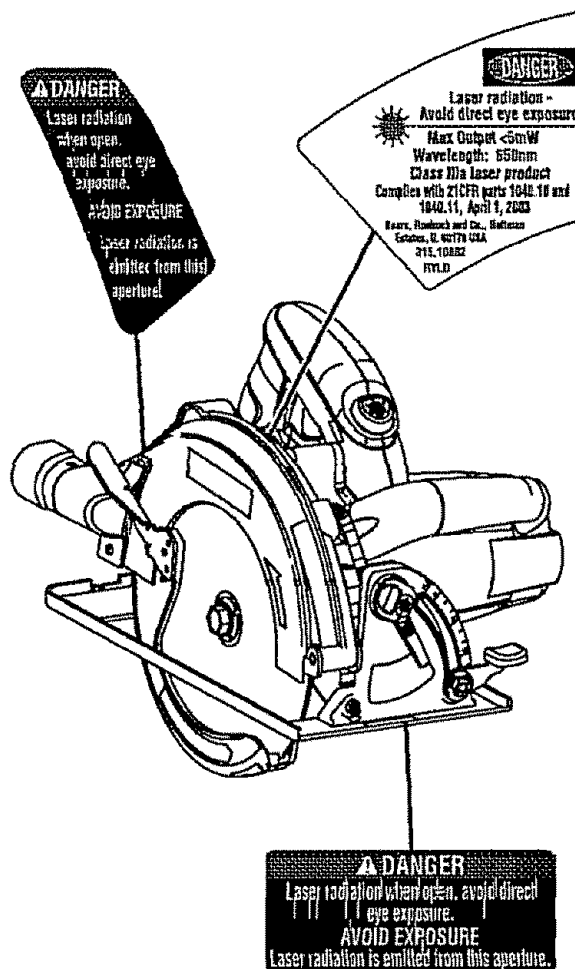



Fig. 25

MAINTENANCE

 **WARNING:** When servicing, use only identical Craftsman replacement parts. Use of any other parts may create a hazard or cause product damage.

 **WARNING:** Always wear safety goggles or safety glasses with side shields during power tool operation or when blowing dust. If operation is dusty, also wear a dust mask.

GENERAL MAINTENANCE

Avoid using solvents when cleaning plastic parts. Most plastics are susceptible to damage from various types of commercial solvents and may be damaged by their use. Use clean cloths to remove dirt, dust, oil, grease, etc.

 **WARNING:** Do not at any time let brake fluids, gasoline, petroleum-based products, penetrating oils, etc., come in contact with plastic parts. Chemicals can damage, weaken or destroy plastic which may result in serious personal injury.

Electric tools used on fiberglass material, wallboard, spackling compounds, or plaster are subject to accelerated wear and possible premature failure because the fiberglass chips and grindings are highly abrasive to bearings, brushes, commutators, etc. Consequently, we do not recommend using this tool for extended work on these types of materials. However, if you do work with any of these materials, it is extremely important to clean the tool using compressed air.

LUBRICATION

All of the bearings in this tool are lubricated with a sufficient amount of high grade lubricant for the life of the unit under normal operating conditions. Therefore, no further lubrication is required.

Only the parts shown on the parts list are intended to be repaired or replaced by the customer. All other parts should be replaced at a Sears Service Center.

CRAFTSMAN CIRCULAR SAW – MODEL NUMBER 315.108620

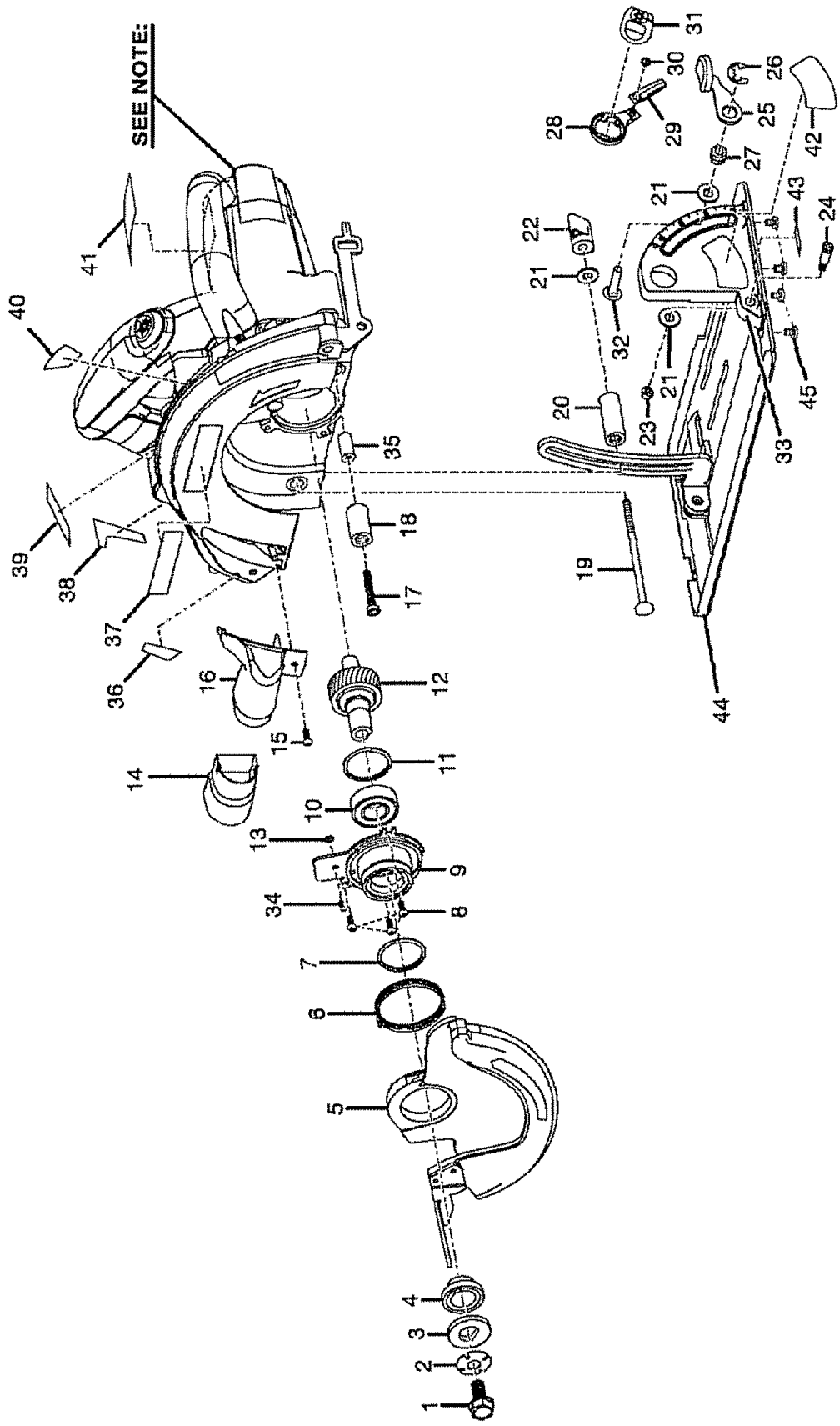

NOTE: The assembly shown represents an important part of the Double Insulated System. To avoid the possibility of alteration or damage to the system, service should be performed by your nearest Sears Repair Center. Contact your nearest Sears Retail Store for Service Center information.



CRAFTSMAN CIRCULAR SAW – MODEL NUMBER 315.108620

The model number will be found on a plate attached to the motor housing. Always mention the model number in all correspondence regarding your **CIRCULAR SAW** or when ordering repair parts.

SEE BACK PAGE FOR PARTS ORDERING INSTRUCTIONS

PARTS LIST

Key No.	Part Number	Description	Qty.
1	660124001	Blade Screw	1
2	680776001	Spring Washer	1
3	680775001	Outer Blade Washer ("D" Washer).....	1
4	680774001	Inner Flange Bushing	1
5	300516027	Lower Blade Guard Assembly.....	1
6	671985001	Torsion Spring	1
7	680778001	Retaining Ring	1
8	660312001	* Screw (8-32 x 3/8 in.) **STD510803.....	3
9	641111001	Lower Guard Support.....	1
10	680769001	Ball Bearing (6003LLB).....	1
11	680767001	Retaining Ring	1
12	300003018	Gear Assembly	1
13	680022001	* Hex Nut (M4 x 3.2)	1
14	550631002	Vacuum Adapter Nozzle.....	1
15	660198001	* Screw (6-32 x 3/8 in. Pan Hd.) **STD600603.....	1
16	551008001	Vacuum Adapter.....	1
17	660180003	* Screw (M5 x 32 mm)	1
18	560844001	Rubber Bumper.....	1
19	660822001	* Carriage Bolt (1/4-20 x 98 mm).....	1
20	550423004	Spacer	1
21	680771001	Washer	3
22	550266003	Knob.....	1
23	670974001	Lock Nut (M5).....	1
24	660824001	Pivot Bolt (M5 x 25 mm).....	1
25	301271001	Lever Assembly.....	1
26	671704001	E-Ring	1
27	671705001	* Hex Nut (1/4-20).....	1
28	513109001	Pointer Bracket.....	1
29	341110001	Pointer	1
30	660113008	* Screw (M2.6 x 4 mm)	1
31	513108001	Knob.....	1
32	660426001	* Carriage Bolt (1/4-20 x 28 mm).....	1
33	640940001	Bevel Bracket	1
34	660212005	* Screw (M4 x 8 mm)	1
35	690500001	Bumper Support.....	1
36	941011002	Rear Aperture Label	1
37	940005054	Logo Plate	1
38	940266003	Scale Label (Depth of Cut)	1
39	940267003	Spindle Lock Label.....	1
40	940006110	Laser Warning Label	1
41	940057057	Data Label	1
42	941012001	Pointer Scale Label	1
43	941011001	Front Aperture Label	1
44	300053016	Base Assembly.....	1
45	660434003	* Screw (M5 x 8 mm Hex Flat Head)	4
	983000817	Operator's Manual	

* Standard Hardware Item – May Be Purchased Locally

** Available From Div. 98 – Source 980.0

*** Complete assortment available at your Nearest Sears Retail Store

