

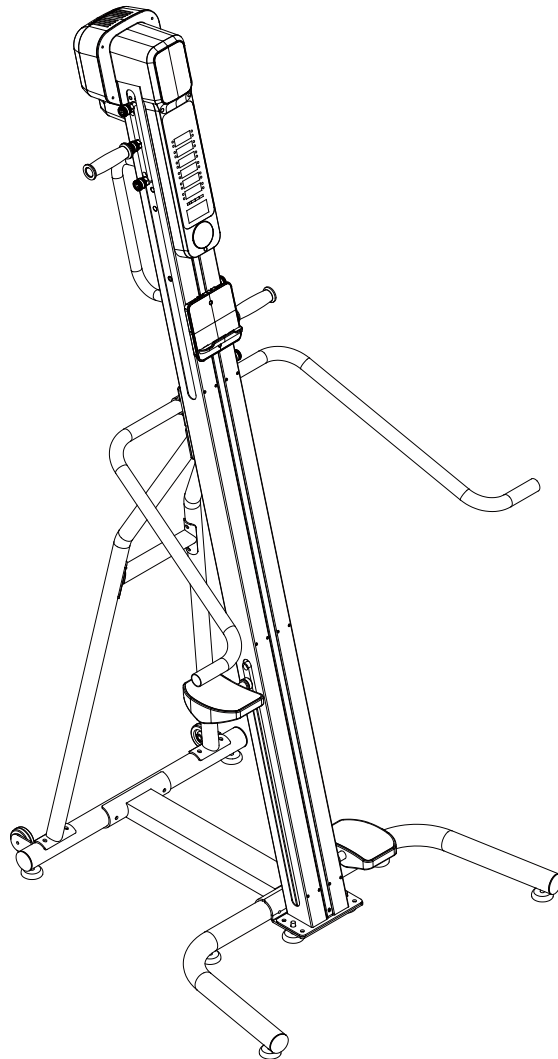

# CL300



Endurance<sup>®</sup>  
by Body-Solid

# CL300 Climber

## User Manual

v. CL300-20230116

# Table of Contents

---

CONGRATULATIONS.....	3
IMPORTANT SAFETY INSTRUCTION.....	4
SAFETY GUIDELINES.....	5 - 6
REFERENCE DRAWING.....	7
HARDWARE PACK LIST.....	8
ASSEMBLY INSTRUCTION.....	9 - 21
OPERATING YOUR CLIMBER.....	22 - 23
OPERATING THE CONSOLE.....	24 - 27
MONITORING YOUR HEART RATE.....	31
CHEST STRAP OPERATION.....	32
MAINTENANCE.....	33
PART LIST.....	35 - 38
EXPLODED VIEW DIAGRAM.....	39



# CONGRATULATIONS

---

## Congratulations!!

Thank you for purchasing your new Endurance Climber.

Using state-of-the-art techniques, robust frame structure and superior ergonomic design, Endurance Climber set a new standard for excellence. The Endurance Climber can improve your quality of life by keeping you fit and healthy, increasing your energy levels and enhancing your lifestyle.

Endurance wants to ensure years of quality workouts with your new Climber so we recommend that you read this manual carefully and thoroughly to fully understand proper use and maintenance of this product. Retain this Owner's Manual for future reference.

Please use this Owner's Manual to make sure that all parts have been included in your shipment. When ordering parts, you must use the part number and description from this Owner's Manual. Use only Endurance replacement parts when servicing this machine. Failure to do so will void your warranty and could result in personal injury.

For information about product operation or service, check out the official website at [www.bodysolid.com/Home/Endurance-Cardio](http://www.bodysolid.com/Home/Endurance-Cardio) or contact an authorized dealer or a factory-authorized service company or contact Customer Tech Support at one of the following:

Toll Free: 1-800-556-3113  
Phone: 1-708-427-3555  
Fax: 1-708-427-3556  
Hours: M-F 8:30-5:00 CST  
E-Mail: [service@bodysolid.com](mailto:service@bodysolid.com)

Or write to:

Endurance Service Department  
1900 S. Des Plaines Ave.  
Forest Park, IL 60130 USA

URANCE®

by *Body-Solid*

# Important Safety Instructions

---

Before beginning any fitness program, you should obtain a complete physical examination from your physician.

*Il est conseillé de subir un examen médical complet avant d'entreprendre tout programme d'exercice. Si vous avez des étourdissements ou des faiblesses, arrêtez les exercices immédiatement.*

---

**When using exercise equipment, you should always take basic precautions, including the following:**

- Read all instructions before using the CL300. These instructions are written to ensure your safety and to protect the unit.
- Do not allow children on or near the equipment.
- Use the equipment only for its intended purpose as described in this guide. Do not use accessory attachments that are not recommended by the manufacturer. Such attachments might cause injuries.
- Wear proper exercise clothing and shoes for your workout, no loose clothing.
- Use care when getting on or off the unit.
- Do not overexert yourself or work to exhaustion.
- If you feel any pain or abnormal symptoms, stop your workout immediately and consult your physician.
- Never operate the unit after it has been dropped or damaged. Return the equipment to a service center for examination and repair.
- Never drop or insert objects into any opening in the equipment.
- Always check the unit before each use. Make sure that all fasteners are secure and in good working condition.
- Do not use the equipment outdoors or near water.

## **PERSONAL SAFETY DURING ASSEMBLY**

- It is strongly recommended that a qualified dealer assemble the equipment. *Assistance is required.*
- Before beginning assembly, please take the time to read the instructions thoroughly.
- Read each step in the assembly instructions and follow the steps in sequence. Do not skip ahead. If you skip ahead, you may learn later that you have to disassemble components and that you may have damaged the equipment.
- Assemble and operate the CL300 on a solid, level surface. Locate the unit a few feet from the walls or furniture to provide easy access.

The CL300 is designed for your enjoyment. By following these precautions and using common sense, you will have many safe and pleasurable hours of healthful exercise with your Endurance CL300.

After assembly, you should check all functions to ensure correct operation. If you experience problems, first recheck the assembly instructions to locate any possible errors made during assembly. If you are unable to correct the problem, call the dealer from whom you purchased the machine or call 1-800-556-3113 for the dealer nearest you.

# Safety Guidelines

---

Successful cardio training programs have one prominent feature in common...safety. Cardio training has some inherent dangers, as do all physical activities. The chance of injury can be greatly reduced or completely removed by using correct running techniques, proper breathing, maintaining equipment in good working condition, and by wearing the appropriate clothing.

---

- **It is highly recommended that you consult your physician before beginning any exercise program. This is especially important for individuals over the age of 35, or persons with pre-existing health problems.**
- **Always warm up before starting a workout. Try to do a total body warm up before you start. It is especially important to warm up the specific muscle groups you are going to be using. This can be as simple as performing a warm up set of high repetitions and light weight for each exercise.**
- **Always wear appropriate clothing and shoes when exercising. Wearing comfortable athletic shoes with good support and loose fitting, breathable clothing will reduce the risk of injury.**
- **Maintaining equipment in proper operating condition is of utmost importance for a safe cardio training program.**
- **Read and study all warning labels on this machine. It is absolutely necessary that you familiarize yourself and all others with the proper operation of this machine prior to use.**
- **Keep hands, limbs, loose clothing and long hair well out of the way of all moving parts.**
- **Inspect the machine daily for loose or worn parts. If a problem is found do not allow the machine to be used until all parts are tightened or worn or defective parts are repaired or replaced.**

URANCE®

by *Body-Solid*

# Safety Guidelines

---

This exercise equipment is designed and built for optimum safety for home use. However, certain precautions always apply whenever you operate any exercise equipment.

Be sure to read the entire manual before assembly and operation of this machine. Also, please note the following safety precautions.

---

## MECHANICAL SAFETY

- Inspect the equipment prior to exercising to ensure that all nuts and bolts are fully tightened before each use.
- Replace any defective components immediately and/or keep the equipment out of use until repair.
- Do not use attachments not recommended by the manufacturer.
- Never drop or insert an object into any opening.
- Only one person may use the Climber at a time.
- Never activate the Climber when someone is standing on the belt.

## APPROPRIATE ATTIRE

- Always wear appropriate clothing.  
Do not wear loose clothing that might catch on any part of this Climber.
- Always wear non-slippery shoes while working with the Climber.  
Do not wear shoes with heels or leather soles.  
Check the soles of your shoes and remove any dirt and embedded stones.

## CHILDREN AND PETS

- Most exercise equipment is not recommended for small children.  
Children should not use the equipment unless they are under *strict* adult supervision.  
To ensure safety, keep young children off the Climber at all times.
- Exercise equipment has many moving parts.  
In the interest of safety, keep others (especially children and pets) at a safe distance while you exercise.

### FCC WARNING - POSSIBLE RADIO/TELEVISION INTERFERENCE

**NOTE:** This equipment has been tested and found to comply with Part 15 of the FCC rules. These limits are designed to provide reasonable protection against harmful interference in a residential installation. Any changes or modifications not expressly approved by the party responsible for the compliance could void the user's authority to operate the equipment. This equipment generates, uses and can radiate radio frequency energy and, if not installed and used in accordance with the instructions, may cause harmful interference to radio communications. However, there is no guarantee that the interference will not occur in a particular installation.

If this equipment does cause harmful radio interference to radio or television reception, which can be determined by turning the equipment off and on, you are encouraged to try to correct the interference by one or more of the following measures:

*Class R (Residential): Private or non-commercial use*

- Reorient or relocate the receiving antenna
- Increase space between the equipment
- Plug the equipment into two electrical outlet located on separate circuits
- Consult an exercise equipment dealer or an experienced radio/TV technician for help

# Reference Drawing

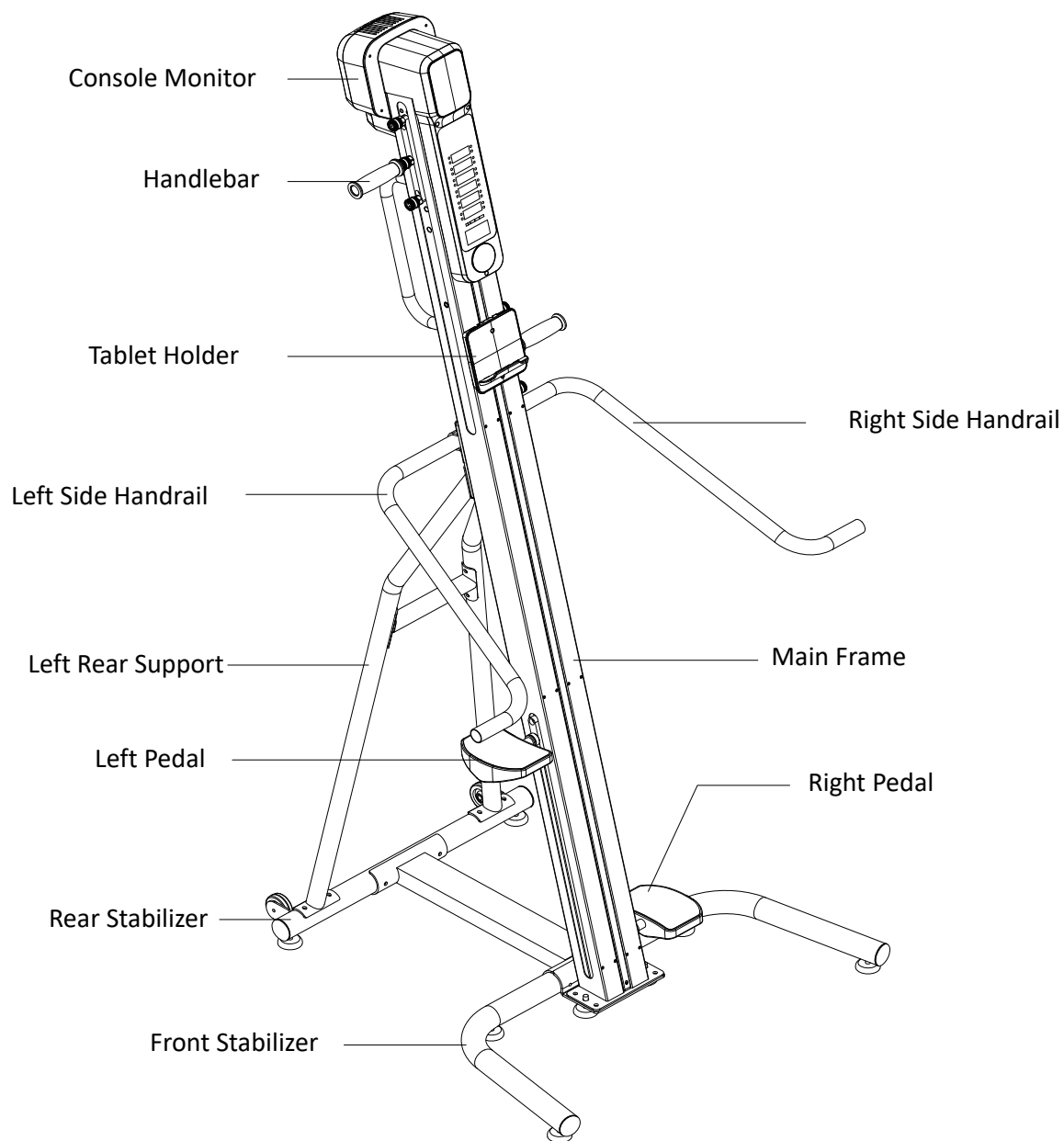





7

URANCE®

by *Body-Solid*

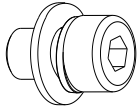
7

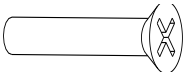
# Hardware Pack List

Picture	Parts	Description	Qty
	109	<b>Pre-assembled Socket Head Cap Screw, M8x14mm (include Spring Washer &amp; Flat Washer)</b>	24 pcs
	105	<b>Socket Head Cap Screw, M8x70mm</b>	4 pcs
	106	<b>Spring Washer, M8</b>	4 pc
	107	<b>Arc Washer, M8</b>	6 pc
	74	<b>Nylon Nut, M8</b>	2 pc
	81	<b>Phillips Flat Head Screw, M5x30mm</b>	2 pc
	88	<b>Allen Wrench 6mm</b>	1 pc
	89	<b>Allen Wrench 4mm</b>	1 pc



# Assembly Instruction

Assembly of the CL300 takes professional installers about 1/2 hour to complete. If this is the first time you have assembled this type of equipment, plan on significantly more time.

**Professional installers are highly recommended!**

However, if you acquire the appropriate tools, obtain assistance, and follow the assembly steps sequentially, the process will take time, but is fairly easy.

## ASSEMBLY TIPS

Read all “NOTES” on each page before beginning each step.

While you may be able to assemble the CL300 using the illustrations only, important safety notes and other tips are included in the text.

Some pieces may have extra holes that you will not use. Use only those holes indicated in the instructions and illustrations.

*NOTE: To find out the length of a particular bolt, measure its shank (the long, narrow part beneath the head).*

Refer to the following diagram:

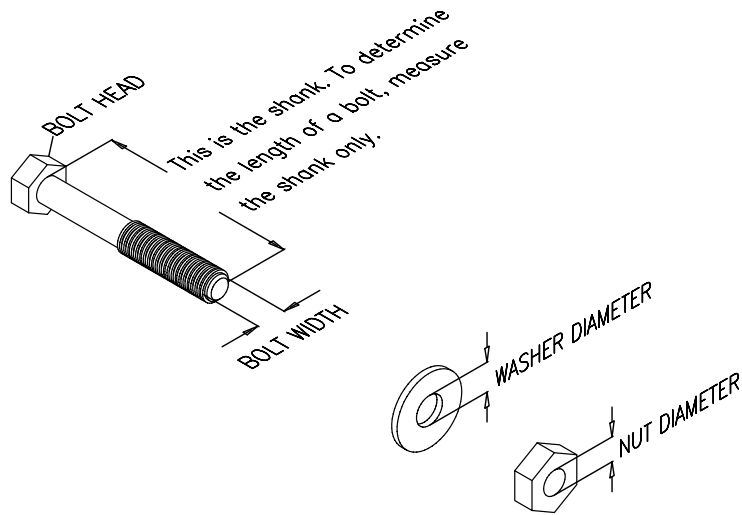

**Do not fully tighten bolts until instructed to do so.**

*NOTE: After assembly, you should check all functions to ensure correct operation. If you experience problems, first recheck the assembly instructions to locate any possible errors made during assembly. If you are unable to correct the problem, call the dealer from whom you purchased the machine or call 1-800-556-3113 for the dealer nearest you.*

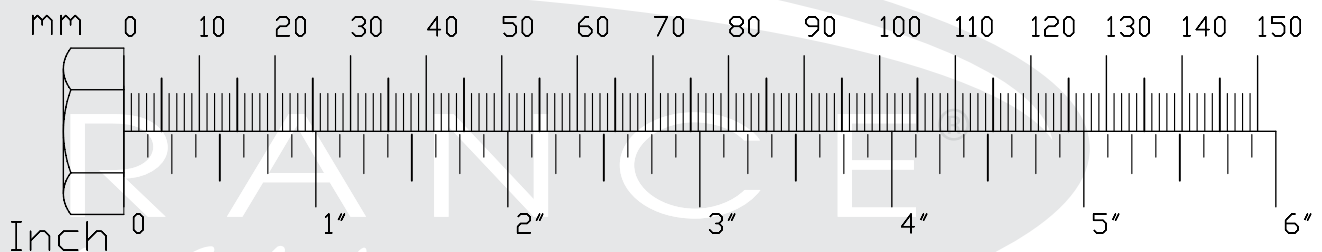

# Step 1

**Be careful to assemble all components in the sequence they are presented.**

**Note: Fully tighten bolts at the End of Step 1B.**

- 1A.** Attach Front Stabilizer (#2) to Center Connection Tube (#4) using:  
**M8x70mm Socket Head Cap Screw (#105), QTY: 2**  
**M8 Lock Washer (#106), QTY: 2**  
**M8 Arc Washer (#107), QTY: 2**
- 1B.** Attach Rear Stabilizer (#2) to Center Connection Tube (#4) using:  
**M8x70mm Socket Head Cap Screw (#105), QTY: 2**  
**M8 Lock Washer (#106), QTY: 2**  
**M8 Arc Washer (#107), QTY: 2**

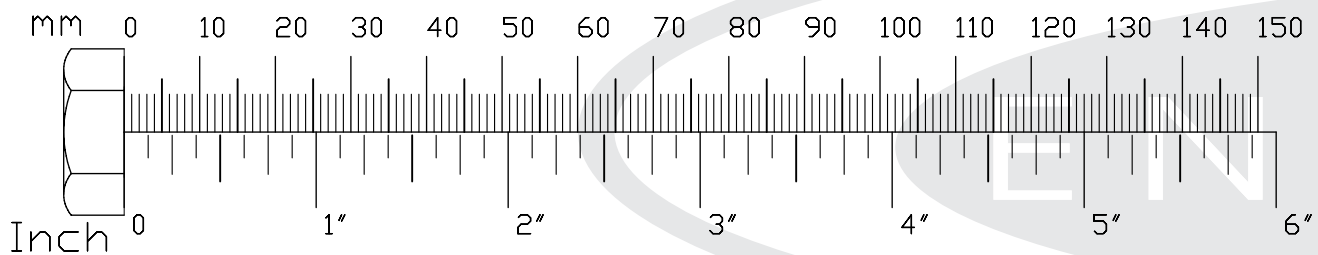

# Step 1

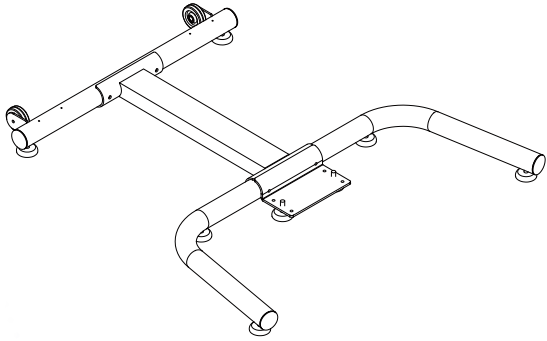

Above shows STEP 1 assembled and completed.

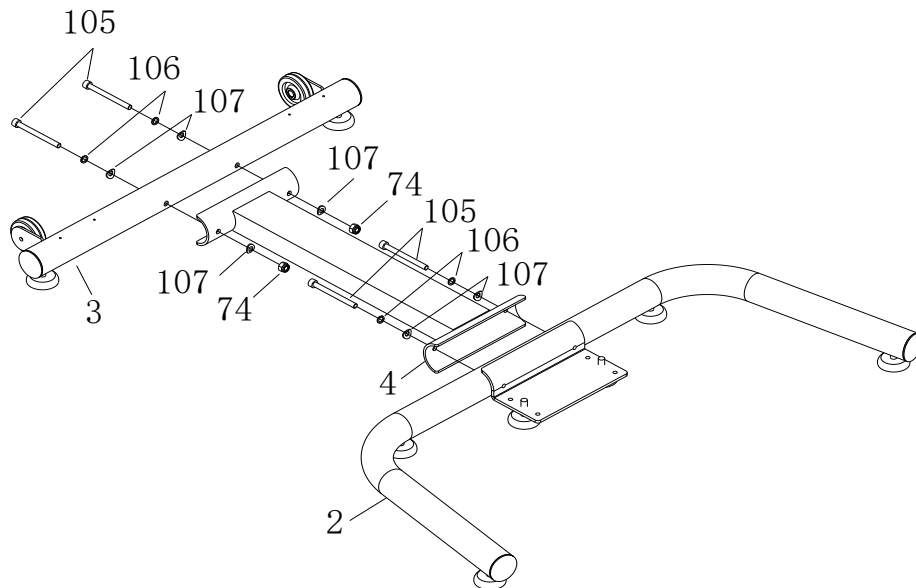

# Step 2

**Be careful to assemble all components in the sequence they are presented.**

**Note: Do not fully tighten bolts until instructed**

- 2A.** Attach Left/Right Support Tube (#5L & #5R) to Support Connection Tube (#108) using:  
**M8x14mm Socket Head Cap Screw with Washers (#109), QTY: 4**
  
- 2B.** Attach Left/Right Support Tube (#5L & #5R) to Rear Stabilizer (#3) using:  
**M8x14mm Socket Head Cap Screw with Washers (#109), QTY: 4**

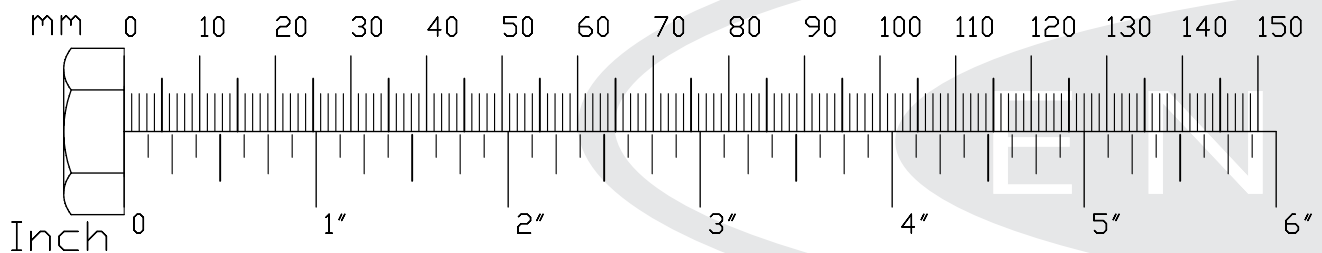

# Step 2

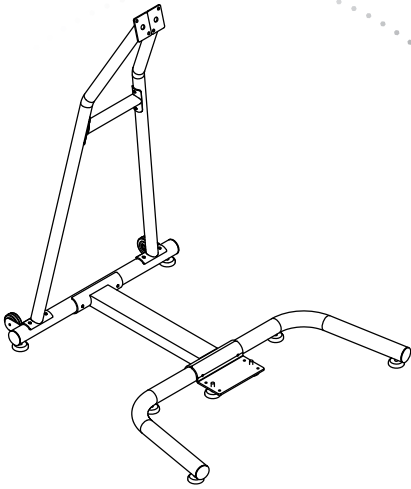

Above shows STEP 2 assembled and completed.

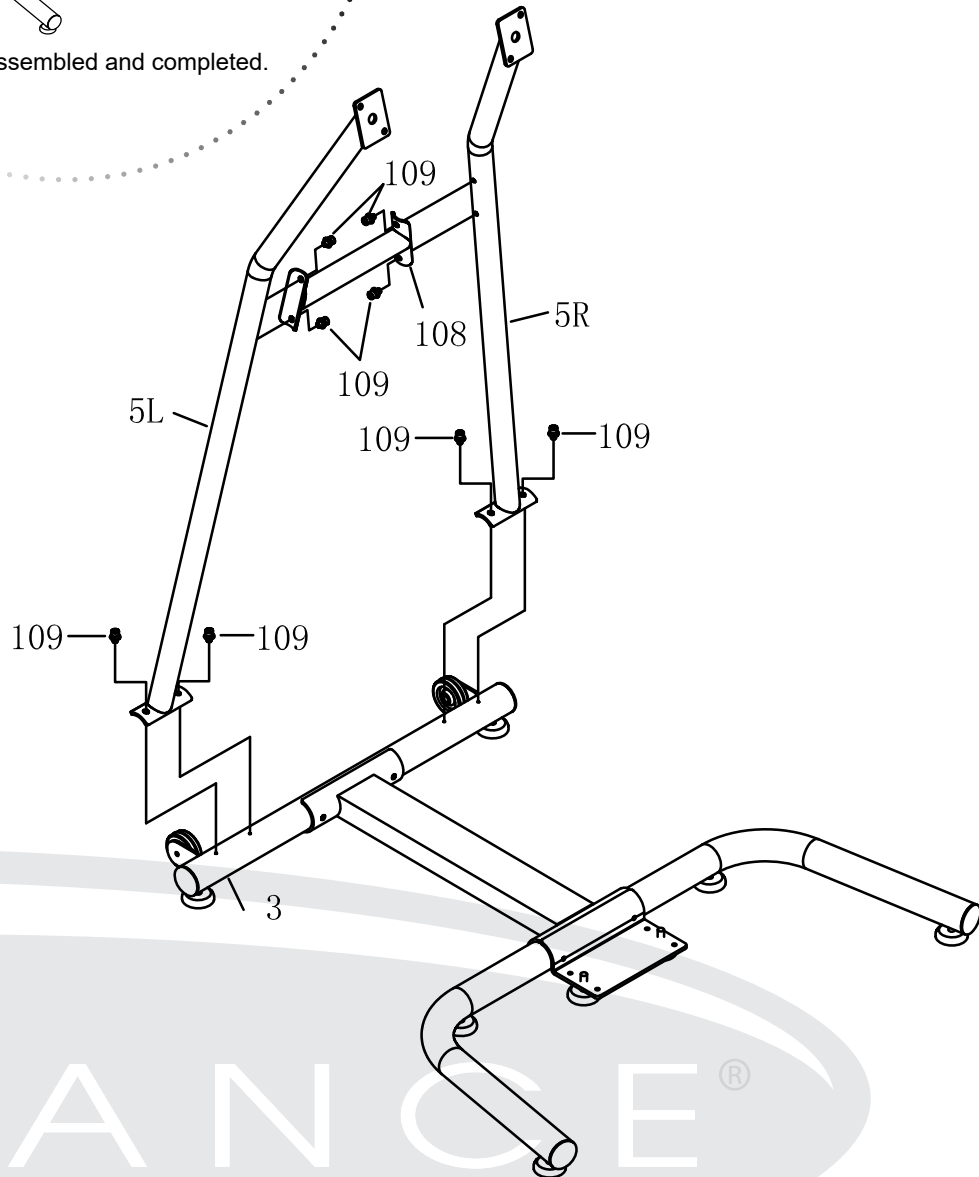

URANCE<sup>®</sup>

by *Body-Solid*

# Step 3

**Be careful to assemble all components in the sequence they are presented.**

**Note: Do not fully tighten bolts until instructed**

- 3A.** Attach Main Frame (#1) to Front Stabilizer (#2) using:  
**M8x14mm Socket Head Cap Screw with Washers (#109), QTY: 4**

**Note: Please have at least two persons to lift and hold the Main Frame (#1) during this Step.**

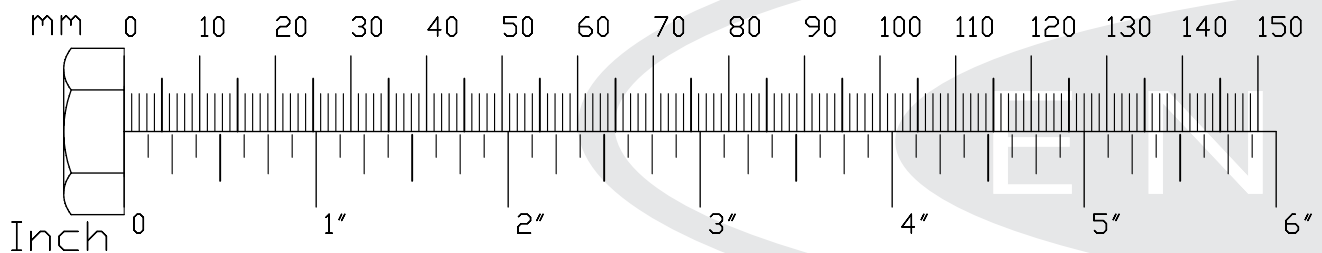

# Step 3

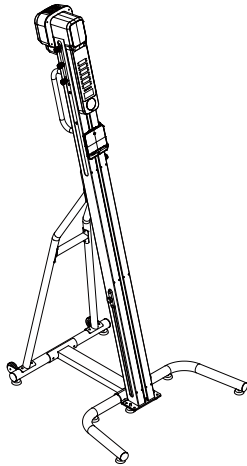

Above shows STEP 3 assembled and completed.

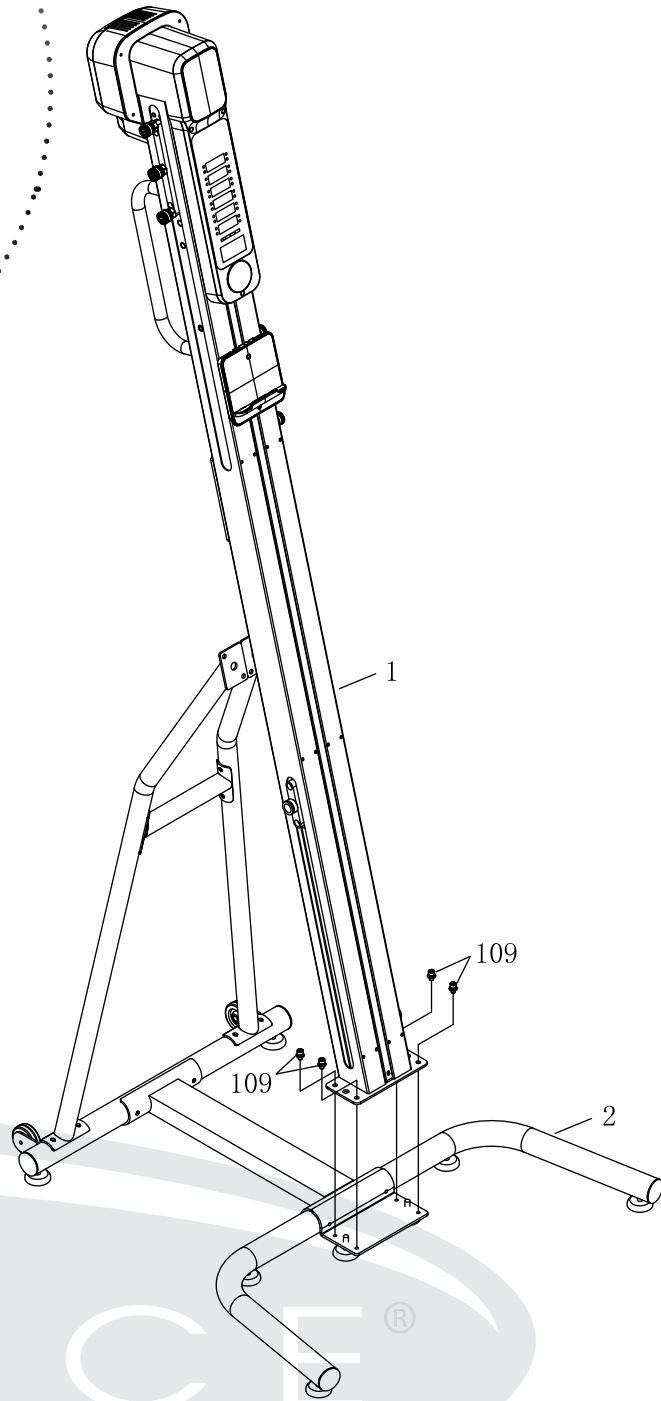

URANCE®

by *Body-Solid*

# Step 4

**Be careful to assemble all components in the sequence they are presented.**

**Note: Fully tighten bolts at the End of below Step.**

- 4A.** Attach Main Frame (#1) to Left/Right Support Tube (#5L & #5R) using: **M8x14mm Socket Head Cap Screw with Washers (#109), QTY: 4**

**Note: Please have at least two persons to hold the Main Frame (#1) during this Step.**

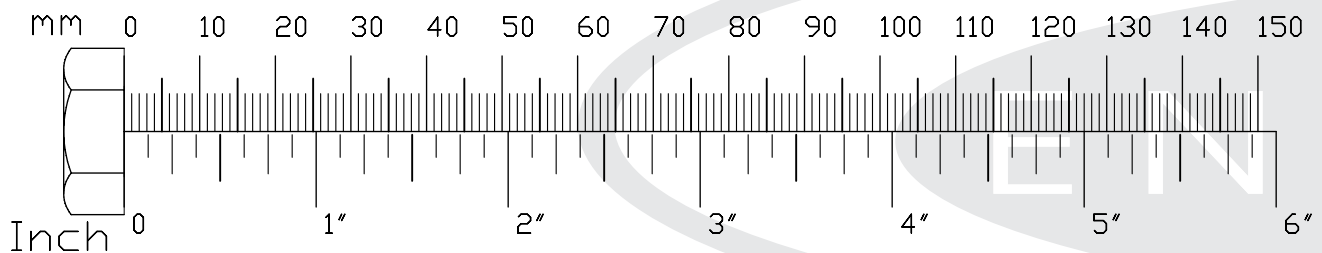

# Step 4

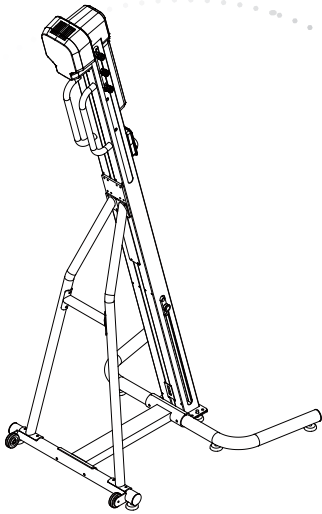

Above shows STEP 4 assembled and completed.

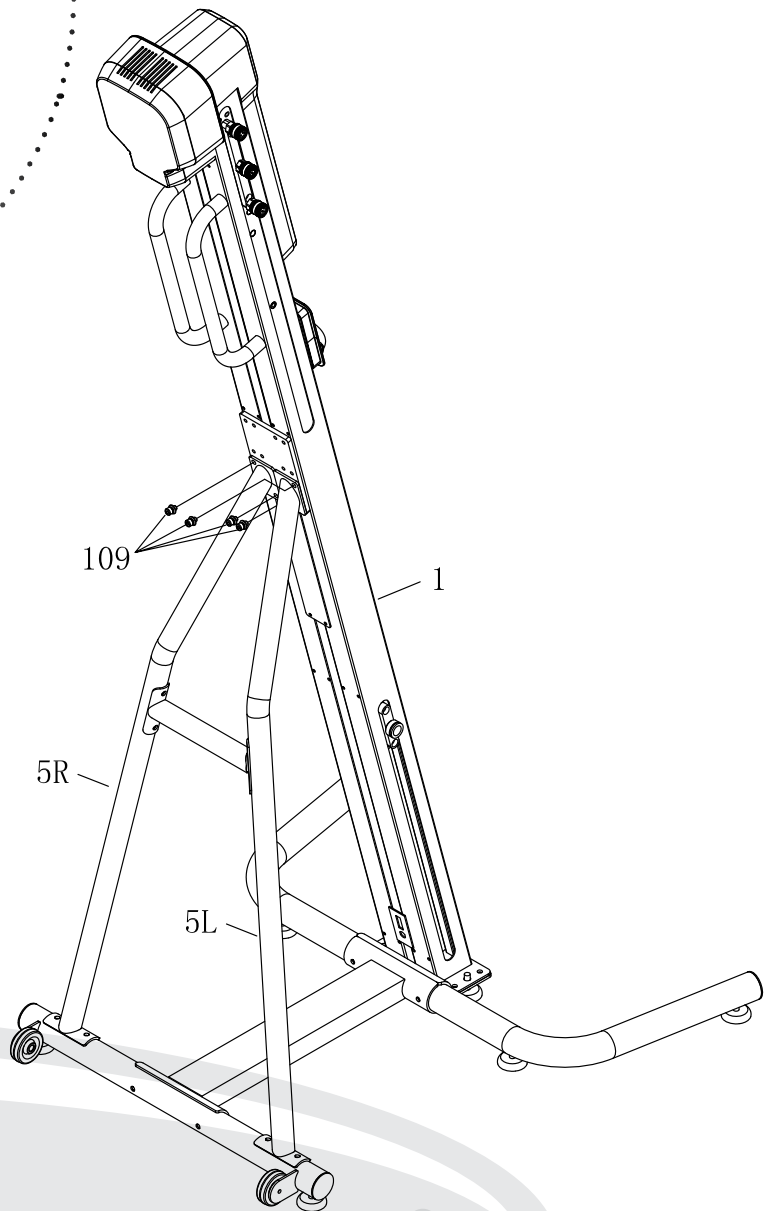

# URANCE®

by *Body-Solid*

# Step 5

**Be careful to assemble all components in the sequence they are presented.**

**Note: Fully tighten bolts at the End of Step 4C.**

- 4A.** Attach Left Side Handrail (#6) to Main Frame (#1) using:  
**M8x14mm Socket Head Cap Screw with Washers (#109), QTY: 4**
- 4B.** Insert Right Side Handrail (#7) into Left Side Handrail (#6)
- 4C.** Attach Right Side Handrail (#7) to Main Frame (#1) using:  
**M8x14mm Socket Head Cap Screw with Washers (#109), QTY: 4**

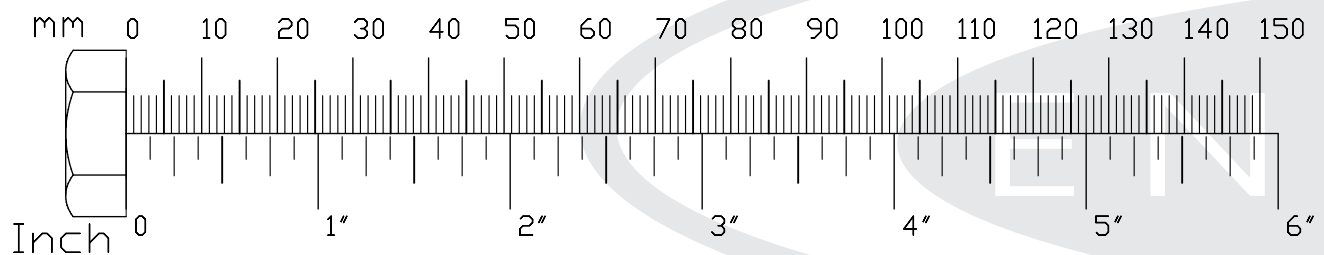

# Step 5

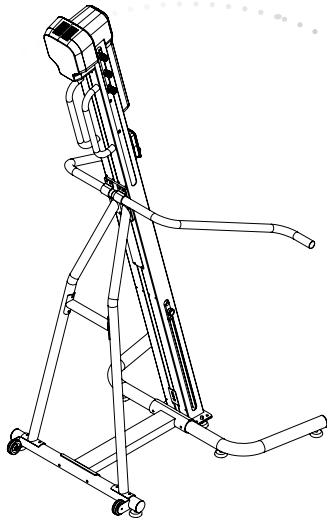

Above shows STEP 5 assembled and completed.

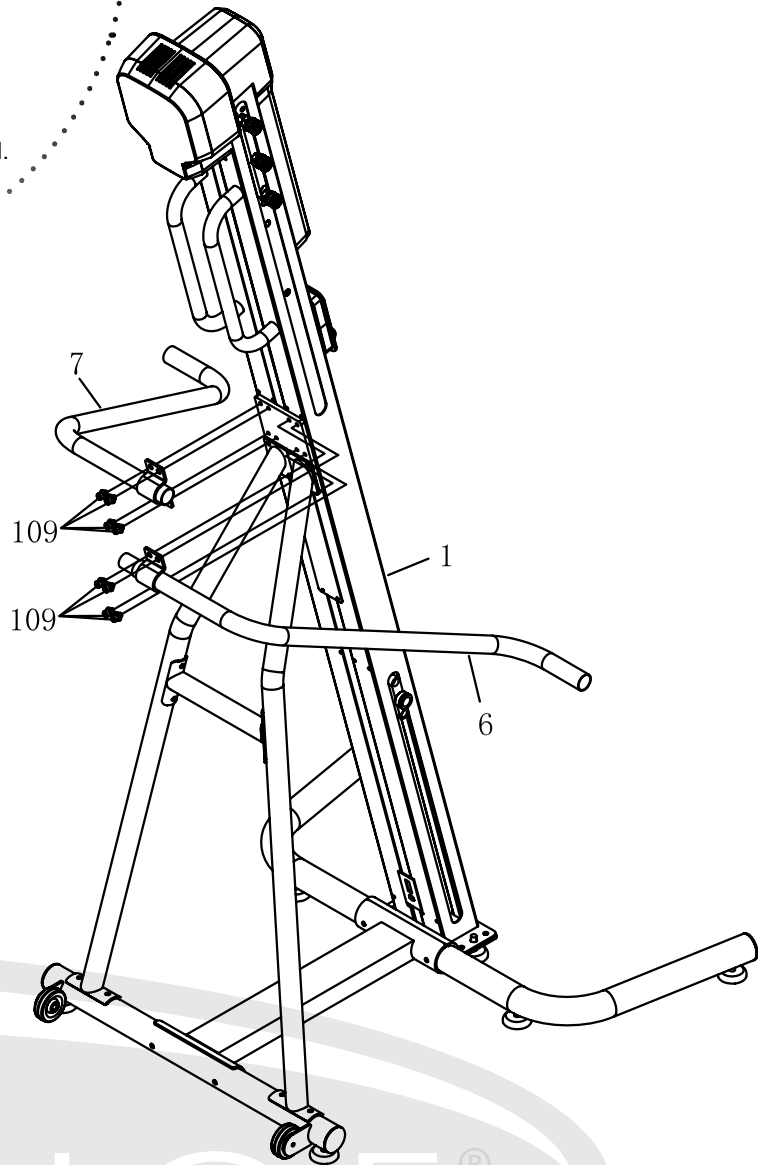

URANCE®

by *Body-Solid*

# Step 6

**Be careful to assemble all components in the sequence they are presented.**

**Note: Fully tighten bolts at the End of each Step.**

- 6A.** Press the Spring loaded Handlebar Lock (#95) inward. Insert the Handlebar (#8) into the Spring Loaded Handlebar Lock (#95). Lock the Handlebar (#8) in place by rotating the Spring Loaded Handlebar Lock (#95)
- 6B.** Attach Left / Right Foot Pedals (#14 / #15) on Left/Right Foot Pedal Connectors (#10L / #10R)

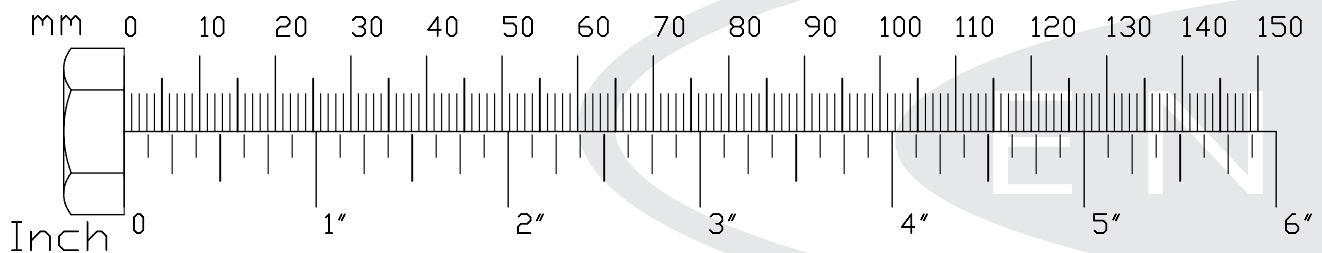

# Step 6

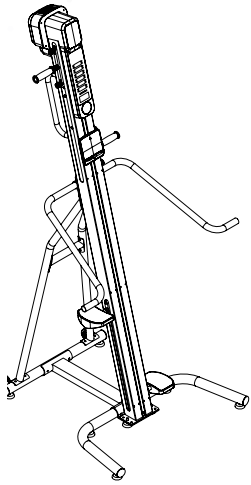

Above shows STEP 6 assembled and completed.

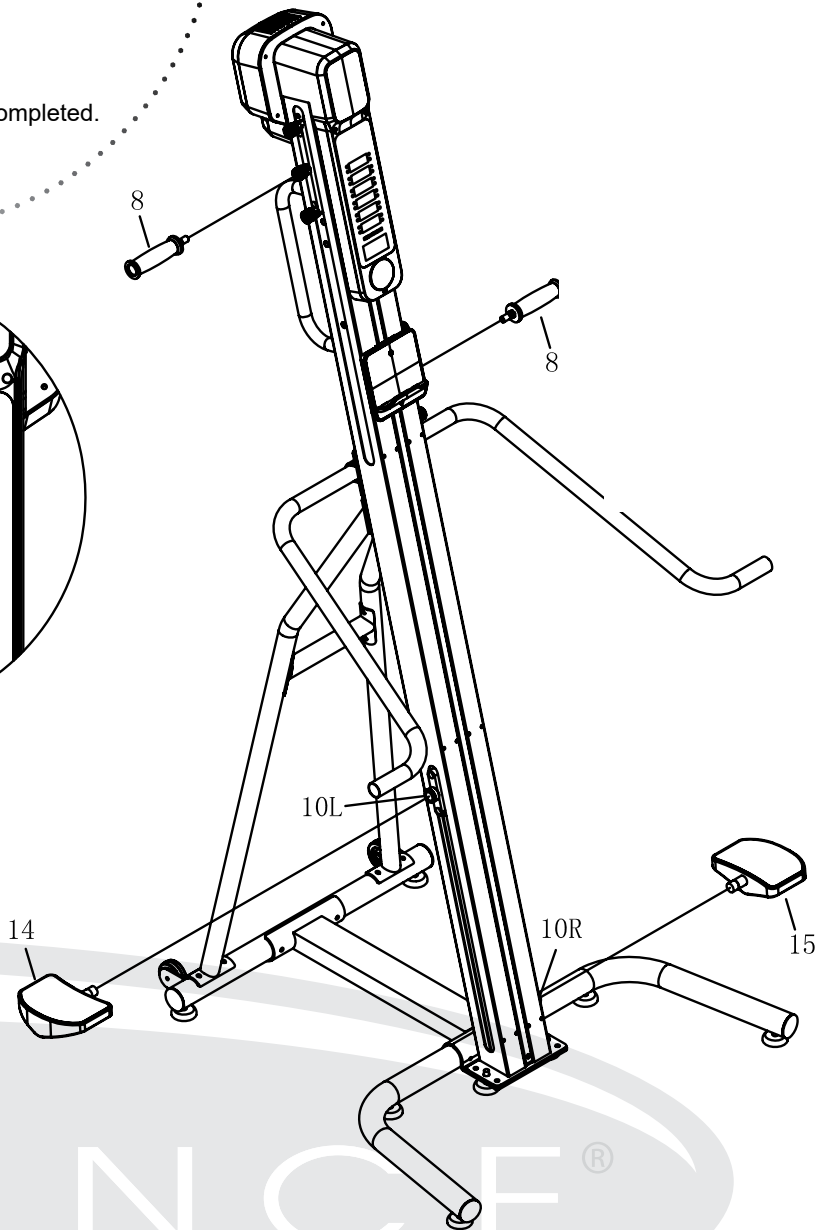
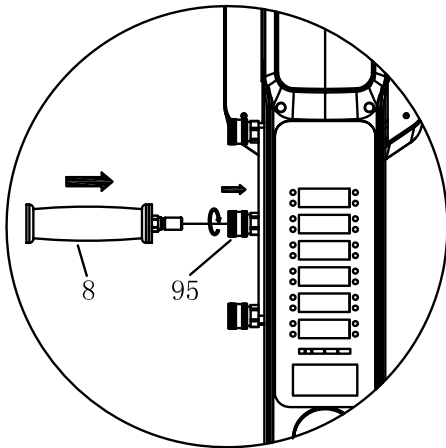

URANCE<sup>®</sup>  
by *Body-Solid*

# Operating your Climber

## TURN POWER ON

The ON/OFF switch is located at the lower back of the Main Frame. Connect the climber to the adapter and then connect the adapter to the electrical outlet. Flip the switch to the "ON" position

## MOVING CLIMBER

Hold the Lift Bar (1-H) with both hands on the back of the Climber and tilt the machine at an angle. Then move the Climber with the Transport Wheels (#40)

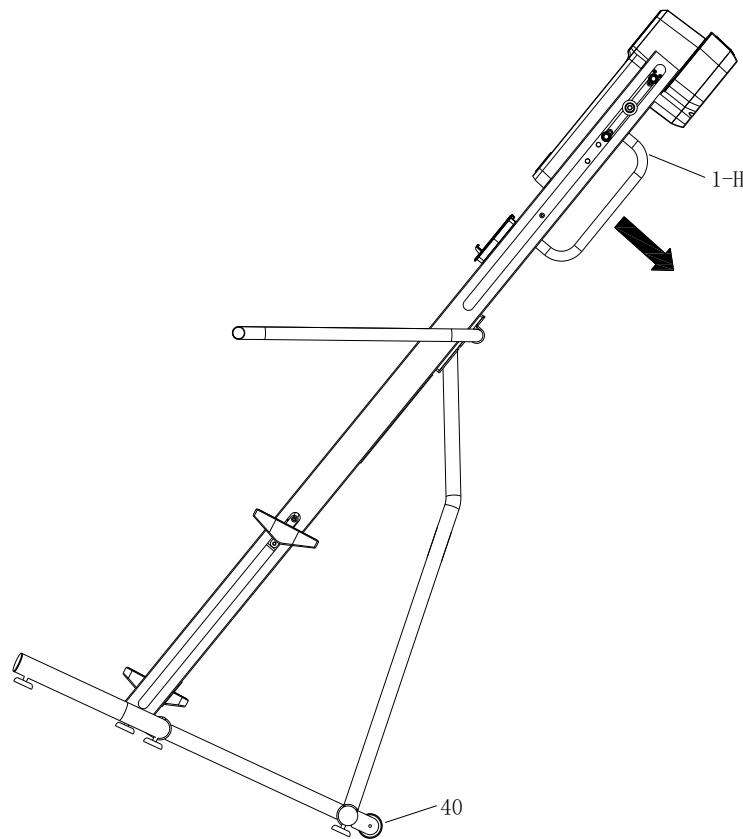

END

# Operating your Climber

## HANDLEBAR POSITION

To change the position, unlock and remove the handle bar (#8) by pressing the Spring Loaded Handlebar Lock (#95) inward. Choose the desired handlebar position. Press the Spring loaded Handlebar Lock (#95) inward. Insert the Handlebar (#8) into the Spring Loaded Handlebar Lock (#95). Lock the Handlebar (#8) in place by rotating the Spring Loaded Handlebar Lock (#95)

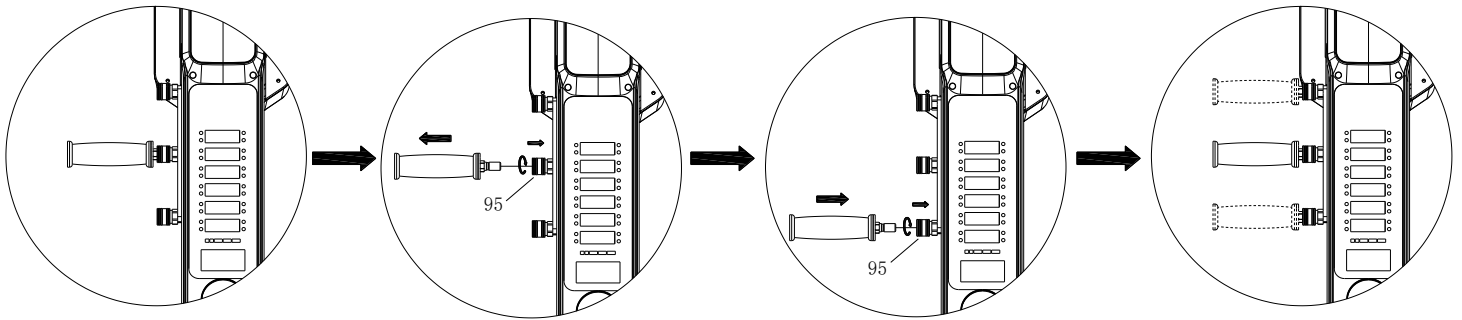

## HEIGHT ADJUSTMENT

The height of Foot Pad (#42) can be adjusted. First, loosen the Foot Pad Adjustment Lever (#90) by rotating it clockwise. Then adjust the height of Foot Pad (#42) to the desired position by turning it clockwise or counterclockwise. Finally, lock the Foot Pad Adjustment Lever (#90) back by rotating it with counterclockwise.

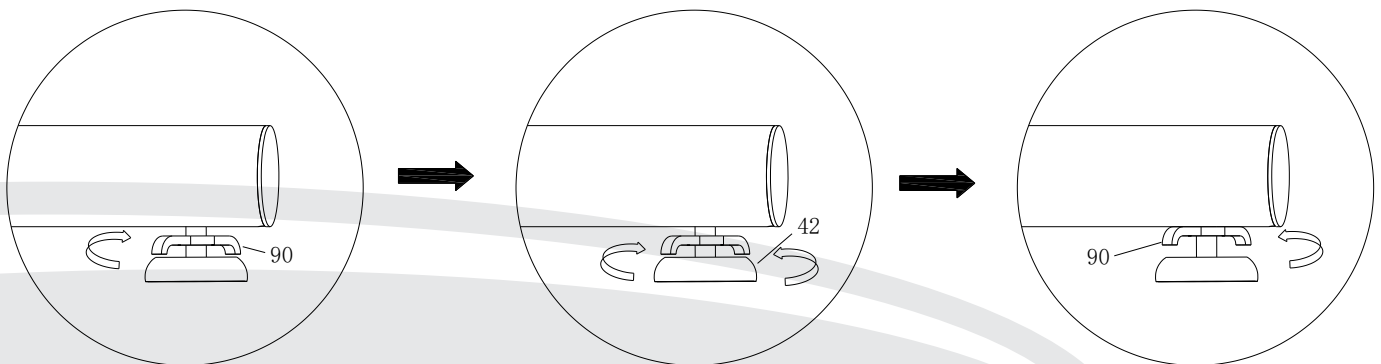

URANCE<sup>®</sup>  
by *Body-Solid*

# Operating the Console



# Operating the Console

## CONSOLE DISPLAY

### TIME:

- Workout time is accumulated under any workout mode, except for Time Countdown Program.
- Display range: 00:00 ~ 99:59 MINUTES:SECONDS.

### DISTANCE:

- Display the total height accumulated during the workout, except for Distance Countdown Program.
- Unit displayed in feet or meter.
- Display range: 0 ~ 9999 feet or meter.

### CALORIES:

- Display the total calories accumulated during the workout, except for Calories Countdown Program.
- Display range: 0 ~ 9999 cal.

### WATT:

- Display the amount of power generated during the workout
- Display range: 0 ~ 9999 watts.

### SPEED:

- Display the current exercising speed during the exercise.
- Unit displayed in feet per minute or meter per minute.
- Display range: 0.0 ~ 999.9 f/min or m/min

### STEP HEIGHT:

- Display the current height of each step at any moment during the exercise.
- Unit displayed in inch or centimeter.
- Display range: 0 ~ 50 cm or 0 ~ 20 inch.

### PULSE:

- Display the heart rate at any moment during the exercise. To use this function, the user must wear a heart rate chest strap.
- Display range: 0 ~ 200 beats per minute.

URANCE®

by *Body-Solid*

# Operating the Console

---

## RESISTANCE LEVEL

- Display resistance level on the bottom screen during exercise.
- Turn the knob clockwise or counter-clockwise to change the resistance level.
- Display range: 01-16

## INITIAL SETUP

### POWER ON:

- Press the “ON/OFF” switch to turn on the console

### POWER OFF:

- Press the “ON/OFF” switch to turn off the console
- When there is no activity for more than 5 minutes, console will automatically enter to sleep mode.

### UNIT, WEIGHT, GENDER, AGE SETTINGS:

- User can choose between two units – metric or imperial (LED matrix displays “**KM**” or “**M**”). During initial setup, User must finish the initial setup followed by choosing unit, user weight, age.
- Rotate the knob to choose between options under each setting and then press the knob to confirm the setting. Then rotate the knob again to proceed to the next setting.
- To change the setting, press the smart knob for 5 seconds in standby mode when LED displays “**P0**”. When LED matrix changes to display “**KM**” or “**M**”, then can proceed to update the setting.
- Setting range for weight: **20 ~ 150 kg** or **44 ~ 330 lbs.**
- Setting range for age: **20 ~ 80** years old.
- In the standby mode (P0), press and hold for 5 seconds to go back to initial setup.



END

# Operating the Console

## SMART KNOB OPERATION

### ROTATION:

- Rotate clockwise or counter-clockwise to choose settings, programs and values.

### PRESS:

- Press the knob to confirm settings, programs or values.
- During Workout Mode, press the knob to pause the program. Press the knob again to resume the program.

### PRESS and HOLD:

- Press and hold for 3 seconds to go back to previous step while doing the setting of any program.
- In the standby mode (P0), press and hold for 5 seconds to go to initial setup.

## PROGRAMS

The console has 15 programs: Quick Start (**P0**), Time Countdown (**TIME**), Distance Countdown (**DIST**), Calories Countdown (**CAL**), 4 Interval (**I1-I4**), 5 Preset Programs (**P1-P5**), User Customize (**USER**), Heart Rate Control (**HRC**).

### QUICK START (P0):

- Rotate the knob until the LED matrix displays “**P0**”
- Press Knob to start the workout program.
- Rotate Knob to change resistance level during workout.

### TIME COUNTDOWN (TIME):

- Rotate the knob until the LED matrix displays “**TIME**”
- Press the knob to go to time setting.
- Rotate the knob to change the target time and press the knob to start the workout program.
- Rotate Knob to change resistance level during workout.

URANCE®

by *Body-Solid*

# Operating the Console

---

## **DISTANCE COUNTDOWN (DIST):**

- Rotate the knob until the LED matrix displays “**DIST**”
- Press the knob to go to distance setting.
- Rotate the knob to change the target distance and press the knob to start the workout program.
- Rotate Knob to change resistance level during workout.

## **CALORIES COUNTDOWN (CAL):**

- Rotate the knob until the LED matrix displays “**DIST**”
- Press the knob to go to calories setting.
- Rotate the knob to change the target calories and press the knob to start the workout program.
- Rotate Knob to change resistance level during workout.

## **INTERVAL (I1):**

- Rotate the knob until the LED matrix displays “**I1**”
- Press the knob to go to the cycle setting.
- Rotate the knob to choose the numbers of cycle and press the knob to start the workout program.
- During the workout program, the user will exercise for **30** seconds and then rest for **30** seconds alternately until the numbers of cycle is reached. The time countdown would not flash during exercise time and then it will flash during rest time
- LED matrix screen display the numbers of cycle left during the workout.
- Rotate Knob to change resistance level during workout.

## **INTERVAL (I2):**

- Rotate the knob until the LED matrix displays “**I2**”
- Press the knob to go to the cycle setting.
- Rotate the knob to choose the numbers of cycle and press the knob to start the workout program.
- During the workout program, the user will exercise for **45** seconds and then rest for **30** seconds alternately until the numbers of cycle is reached. The time countdown would not flash during exercise time and then it will flash during rest time

END

# Operating the Console

- LED matrix screen display the numbers of cycle left during the workout.
- Rotate Knob to change resistance level during workout.

## **INTERVAL (I3):**

- Rotate the knob until the LED matrix displays “**I3**”
- Press the knob to go to the cycle setting.
- Rotate the knob to choose the numbers of cycle and press the knob to start the workout program.
- During the workout program, the user will exercise for **60** seconds and then rest for **30** seconds alternately until the numbers of cycle is reached. The time countdown would not flash during exercise time and then it will flash during rest time.
- LED matrix screen display the numbers of cycle left during the workout.
- Rotate Knob to change resistance level during workout.

## **INTERVAL (I4):**

- Rotate the knob until the LED matrix displays “**I4**”
- This is a customized interval program. Press and rotate the knob to enter the setting in the following sequence: Exercise Time→Rest Time→Cycles.
- During the workout program, the user will exercise for **SET** seconds and then rest for **SET** seconds alternately until the numbers of cycle is reached. The time countdown would not flash during exercise time and then it will flash during rest time.
- LED matrix screen display the numbers of cycle left during the workout.
- Rotate Knob to change resistance level during workout.

## **PRESET PROGRAMS (P1-P5):**

- Rotate the knob until the LED matrix displays “P1, P2, P3, P4 or P5”. Press to Choose one of the Preset programs. Below table is the description of the Preset programs.
- Rotate the knob to choose target time and press the knob to start the workout program

URANCE®

by *Body-Solid*

# Operating the Console

Sections Programs		Target time/16 = Time in each section															
		1	2	3	4	5	6	7	8	9	10	11	12	13	14	15	16
P1	Resistance	1	1	3	3	1	1	3	3	1	1	3	3	1	1	3	3
P2	Resistance	3	3	5	5	3	3	5	5	3	3	5	5	3	3	5	5
P3	Resistance	5	5	10	10	5	5	10	10	5	5	10	10	5	5	10	10
P4	Resistance	1	1	10	10	1	1	10	10	1	1	10	10	1	1	10	10
P5	Resistance	1	1	3	3	5	5	7	7	7	7	5	5	3	3	1	1

## USER CUSTOMIZED PROGRAM (USER):

- Rotate the knob until the LED matrix displays “USER”.
- Press the knob to go to the target time setting.
- Rotate the knob to choose target time and press the knob to go to resistance setting.
- Rotate the knob to choose resistance level and press the knob to confirm.
- Repeat the previous step to choose resistance levels for the remaining 15 sections.

## HEART RATE CONTROL PROGRAM (HRC):

- Rotate the knob until the LED matrix displays “HRC”.
- Press the knob to go to the Target Time setting.
- Rotate the knob to choose Target Time and press the knob to go to target heart rate setting.
- Rotate the knob to choose Target Heart Rate (80 - 160bpm) and press the knob to confirm.
- If Heart Rate < Target Heart Rate -5, then the resistance will increase by 1 level every 30 seconds, up to the maximum.
- If Target Heart Rate -5 <= HR <= Target Heart Rate +5, then the resistance level will stay the same.
- If Target Heart Rate +5 < Heart Rate, then the resistance will decrease by 1 level every 30 seconds, up to the minimum.
- If the console doesn't detect your Heart Rate, then the resistance level will stay the same.

END

# Monitoring Your Heart Rate

## FITNESS SAFETY

The Heart Rate chart indicates average rate zones for different ages. A variety of different factors (including medication, emotional state, temperature and other conditions) can affect the target heart rate zone that is best for you. Your physician or health care professional can help you determine the exercise intensity that is appropriate for your age and condition.

(MHR) = Maximum Heart Rate

(THR) = Target Heart Rate

$220 - \text{Age} = \text{Maximum Heart Rate (MHZ)}$

$\text{MHZ} \times .60 = 60\% \text{ of your Maximum Heart Rate.}$

$\text{MHZ} \times .75 = 75\% \text{ of your Maximum Heart Rate.}$

For example, if you are 30 years old, your calculations will be as follows:

$220 - 30 = 190$

$190 \times .60 = 114$  (Low End or 60% of MHZ)

$190 \times .75 = 142$  (High End or 75% of MHZ)

30 Year-Old (THR) Target Heart Rate would be 114-142

Maximum Heart Rate (MHR)

HEART RATE TRAINING ZONE						
MAX	BEATS PER MINUTE					
85%	170	161	153	144	136	128
70%	140	133	126	119	112	105
60%	120	114	108	102	96	90
AGE	20	30	40	50	60	70

Heart Rate Training Zone<sup>®</sup>

URANCE<sup>®</sup>  
by Body-Solid

# Chest Strap Operation

---

Your Endurance® Climber has the capability to determine Heart Rate with the use of a Heart Rate Chest Strap. A Heart Rate Chest Strap can be purchased separately. The frequency of the receiver is 5KHz

It is suggested for the Chest Strap Transmitter that you position the transmitter as close to your heart as possible, against the skin, 1-2 inches below the pectoral muscles. For best results, moisten the back of the transmitter for better contact.

## **SAFETY PRECAUTIONS AND TIPS FOR CHEST STRAP**

1. It is the owner's responsibility to ensure that all users of this unit have read the Owner's Manual and are familiar with warnings and safety precautions.
2. Do not place chest strap near devices that generate large magnetic fields. TV sets, electric motors, radios, and high voltage power lines can affect the transmitter's performance. These items can interfere with the heart rate signal and possibly affect the heart rate readings on the console.
3. Handle the Chest Strap with care. Dropping the transmitter might cause damage that could void the warranty.
4. Do not use the chest strap if you have a cardiac pacemaker or if you are taking medications for a heart condition. Medication or electrical pulses from the pacemaker can interfere with accurate heart rate readings.
5. Do not bend the strips inside the chest strap. This can cause the chest strap to lose conductivity.
6. The chest strap has batteries that need to be replaced periodically. A faulty battery can cause inaccurate reading.



END

# Maintenance

## CABLE ADJUSTMENT

Over time, the cable may get looser. Please follow the guideline for adjustment.

1. Remove the Back Cover (20) and loosen the Flat Socket Head Cap Screw, M8x22 (115) by using Allen Wrench.
2. Adjust the Hex Nut M10 (79) to the desired tightness by using Open End Wrench 13-15-17mm (91).
3. Then tighten the Flat Socket Head Cap Screw, M8x22 (115).
4. Attach the Back Cover (20) to Main Frame (1) by using Button Head Cap Screw M5x8mm (59).

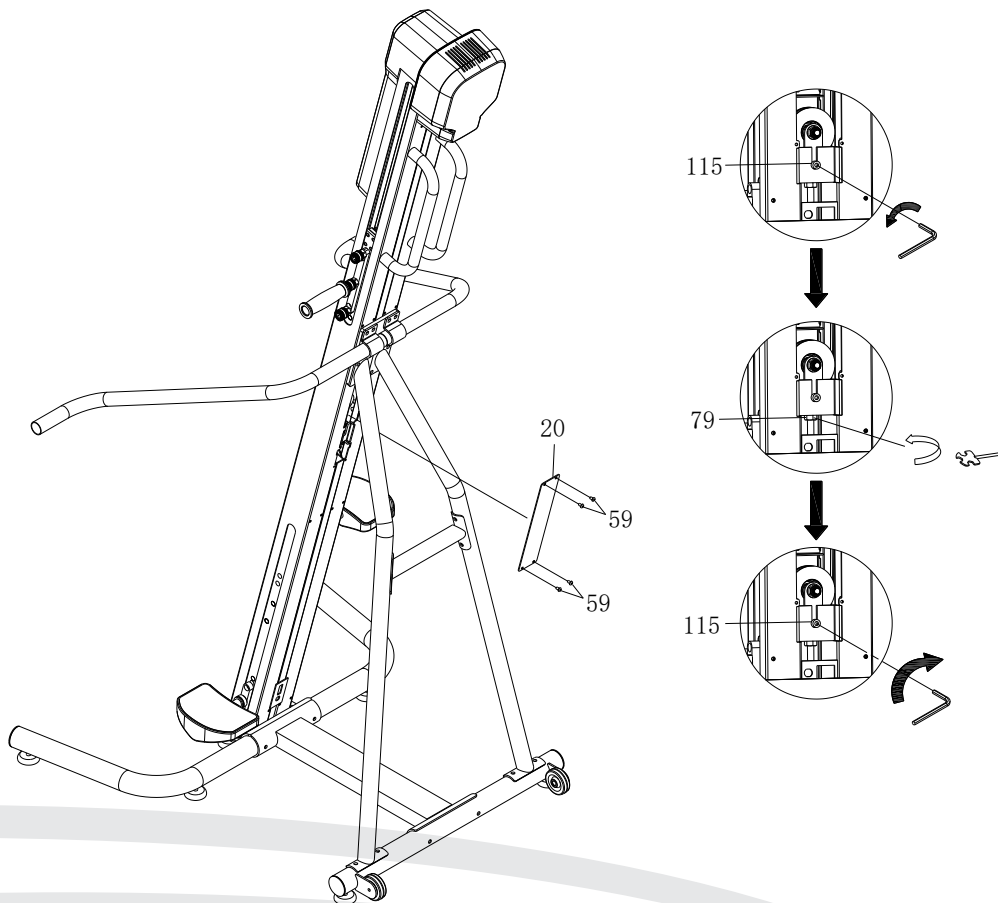

URANCE<sup>®</sup>

by *Body-Solid*

# Maintenance

---

## MAGNETIC BRAKE VALUE SETTING ADJUSTMENT

- Resistance force level can be changed by changing the magnetic brake value
- In the standby mode (P0), Press the Knob and hold it for 10 seconds. LED screen will display the default setting of the magnetic brake value. Rotate the knob to increase/ decrease the value with range from **30 - 50**. Press the knob to confirm the value with LED displaying "OK". The factory preset value is **40**.



END

# Parts List

<b>PART#</b>	<b>DESCRIPTION</b>	<b>QTY</b>
1	Main Frame	1
2	Front Stabilizer	1
3	Rear Stabilizer	1
4	Base Connection Tube	1
5L	Left Support Tube	1
5R	Right Support Tube	1
6	Left Side Handrail	1
7	Right Side Handrail	1
8	Handlebar	2
9L	Left Traveling Bracket	1
9R	Right Traveling Bracket	1
10L	Left Foot Pedal Connector	1
10R	Right Foot Pedal Connector	1
11	Handlebar Adjustment Base	2
12	Motor Bracket	1
13	Cable Adjustment Bracket	1
14	Left Foot Pedal	1
15	Right Foot Pedal	1
16	Belt Fixation Bracket	2
17	Speed Sensor Counter	1
18	Bearing Spacer $\varnothing 20 \times \varnothing 14 \times \varnothing 10 \times 15 \text{mm}$	2
19	Front Cover	1
20	Back Cover	1
22	Braking System Motor	1
23	Aluminum Alloy Pulley	1
24	Bearing 6000	33
25	C Ring $\varnothing 26$	1

URANCE®

by *Berry Sisk* Part numbers are required when ordering parts.

# Parts List

<b>PART#</b>	<b>DESCRIPTION</b>	<b>QTY</b>
26	Roller Guide Rail	4
27	Roller $\varnothing 41.5 \times \varnothing 35.5 \times \varnothing 21 \times 28.5 \text{mm}$	16
28	Base of Bearing 6004	1
29	Bearing 6004	1
32	Belt Pulley Axis	1
33	Belt Pulley	1
34	Belt D8M15-760mm	1
35	Console Monitor Front Cover	1
36	Console Monitor Back Cover	1
37	Tablet Holder	1
38	Tablet Holder Base	1
40	Transport Wheel	2
42	Stabilizer Foot Pad	8
43	Cushion M6x $\varnothing 26 \times 36 \text{mm}$	2
44	Cable	1
47	Power Switch	1
48	Power Cord	1
49	LED Control Knob	1
50	Power Supply (Input 100-240V AC, Output 24V DC)	1
51	Fan	1
52	Speed Sensor	1
54	DC Power Cable	1
56	Phillips Pan Head Self-Tapping Screw, ST4.2x16mm	4
57	Phillips Pan Head Screw, M4x30mm	4
59	Button Head Cap Screw, M5x8mm	37
60	Button Head Cap Screw, M6x8mm	27
61	Flat Washer M6	22
62	Socket Head Cap Screw, M4x20mm	8
66	Button Head Cap Screw, M6x12mm	8

# Parts List

<b>PART#</b>	<b>DESCRIPTION</b>	<b>QTY</b>
67	Socket Head Cap Screw, M6x16mm	6
68	Spring Washer M6	6
69	Socket Head Cap Screw, M8x10mm	8
72	Socket Head Cap Screw, M8x40mm	2
73	Flat Washer M8	4
74	Nylon Nut M8	4
75	Button Head Cap Screw, M10x45mm	1
76	Flat Washer M10	1
77	Nylon Nut M10	1
78	Sc	2
79	Hex Nut M10	1
80	C Ring $\Phi$ 20	2
81	Phillips Flat Head Screw, M5 x 30mm	2
82	Upper Tablet Holder Hook	1
83	Bungee Cord $\varnothing$ 4x 350mm	1
84	EVA Pad (Upper Tablet Holder Hook)	1
85	EVA Pad (Tablet Holder Base)	1
88	Allen Wrench 6mm	1
89	Allen Wrench 4mm	1
90	Foot Pad Adjustment Lever	6
91	Open End Wrench 13-15-17mm	1
92	Roller Protector	2
93	Long Parallel Key	1
94	Short Parallel Key	1
95	Spring Handlebar Lock	6
96	Spring Handlebar Lock Axis	2
97	Handlebar Grip	2
99	LED Console	1

URANCE®

by *Berry Sisk* Part numbers are required when ordering parts.

# Parts List

<b>PART#</b>	<b>DESCRIPTION</b>	<b>QTY</b>
100	Nylon Spacer $\varnothing 9 \times \varnothing 5 \times 6 \text{mm}$	2
101	Socket Head Cap Screw, M5x37mm	2
102	Socket Head Cap Screw, M5x45mm	1
103	Socket Head Cap Screw, M5x10mm	4
104	Flat Washer 16*6.2*1.5T	1
105	Socket Head Cap Screw, M8x70mm	4
106	Lock Washer M8	4
107	Arc Washer M8	6
108	Support Connection Tube	1
109	Socket Head Cap Screw, M8x14mm (with Spring Washer & Flat Washer)	24
110	Adjustment Spacer $\Phi 12 \times \Phi 8.2 \times 11$	1
111	Flat Washer $\Phi 38 \times \Phi 12 \times 3$	2
112	Counterbored Washer	2
113	Star Nut (Double Layer) M6*10	2
114	Hex Head Cap Screw, M6x12	2
115	Flat Socket Head Cap Screw, M8x22	1
116	C Ring $\Phi 25$	1



# Exploded View Diagram

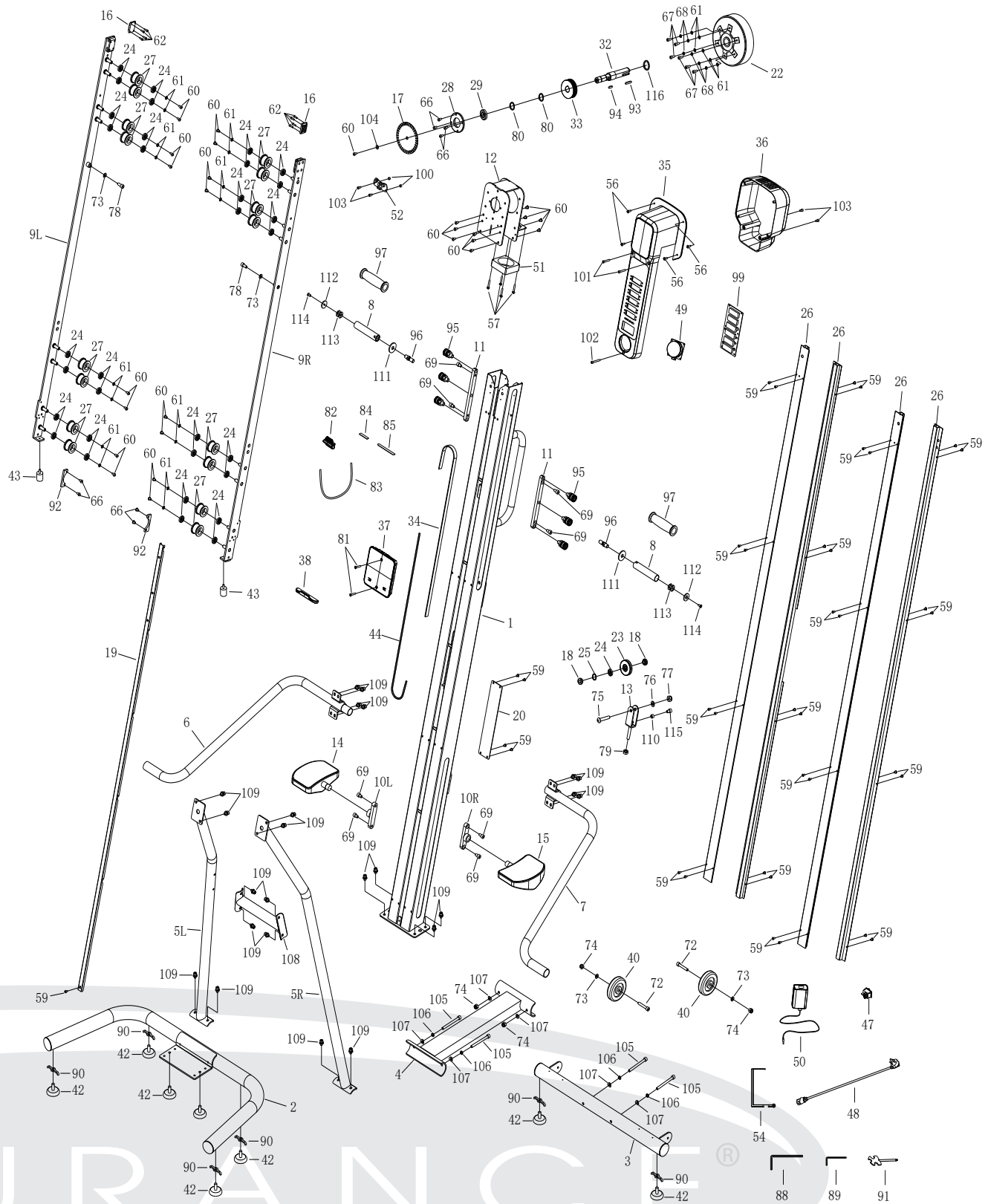

URANCE<sup>®</sup>  
by Body-Solid



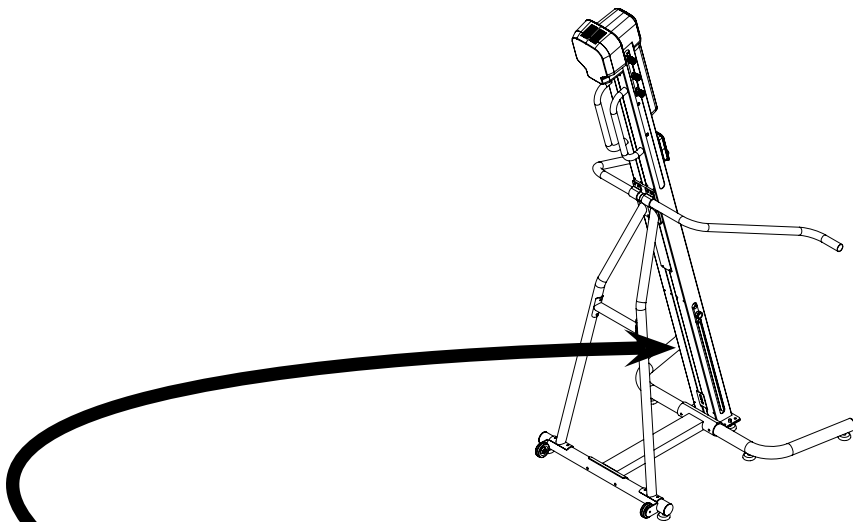

<b>Serial Number is Located on the Frame</b>	
Model Name:	_____ CL300 _____
Purchase Date:	_____
Serial Number:	017979- _____



**Customer Tech Support Hotline**

Toll Free: 1-800-556-3113  
Phone: 1-708-427-3555  
Fax: 1-708-427-3556  
Hours: M-F 8:30-5:00 CST  
E-Mail: [service@bodysolid.com](mailto:service@bodysolid.com)

