



Thinking of you
Electrolux



.....
User manual

.....
Cooker

.....
EVE611SA EVE616BA
EVEP611SA EVEP616BA
EVE613SA EVEP618BA
EVEP613SA EVE623SA
EVE614BA EVEP623SA
EVEP614BA EVEP626BA
EVEP615SA EVE633SA



WE'RE THINKING OF YOU

Thank you for purchasing an Electrolux appliance. You've chosen a product that brings with it decades of professional experience and innovation. Ingenious and stylish, it has been designed with you in mind. So whenever you use it, you can be safe in the knowledge that you'll get great results every time.

Welcome to Electrolux.

LEGEND

The symbols you will see in this booklet have these meanings:



WARNING!

This symbol indicates information concerning your personal safety



CAUTION!

This symbol indicates information on how to avoid damaging the cooker or cabinet



IMPORTANT!

This symbol indicates tips and information about use of the cooker



ENVIRONMENT!

This symbol indicates tips and information about economical and ecological use of the cooker

CONDITIONS OF USE

This appliance is intended to be used in household and similar applications such as:

- Staff kitchen areas in shops, offices and other working environments
- Farm houses
- By clients in hotels, motels and other residential type environments
- Bed and breakfast type environments.
- Catering and similar non-retail applications

RECORD MODEL AND SERIAL NUMBER HERE:

Model: _____

Serial No: _____

CONTENTS

3	Before using your appliance
3	Important safety instructions
4	General cautions
5	Identifying the appliance
6	EVE611SA, EVE614BA
7	- Before using the appliance
9	- Cooking functions
10	- Operating sequence
11	- Using the appliance
13	- Getting to know the oven
14	EVEP611SA, EVEP614BA
15	- Before using the appliance
17	- Cooking functions
18	- Operating sequence
19	- Using the appliance
21	- Getting to know the oven
22	- Cleaning the oven
23	EVE613SA, EVE616BA
24	EVE623SA, EVE633SA
25	- Before using the appliance
27	- Cooking functions
28	- Operating sequence
29	- Using the appliance
32	- Getting to know the oven
33	EVEP613SA, EVEP615SA, EVEP616BA, EVEP618BA
34	- Before using the appliance
36	- Cooking functions
38	- Operating sequence
39	- Using the appliance
44	- Cleaning the oven
46	- Getting to know the oven
47	Cooking guide
52	Dealing with cooking problems
53	Cleaning the appliance
54	- Cleaning the accessories
56	- Cleaning the oven door
59	Tips and troubleshooting
61	Installation of the appliance
63	Technical specifications
67	Warranty

BEFORE USING YOUR APPLIANCE

Before you use the appliance, we recommend that you read through the relevant sections of this manual, which provides the description of your appliance and its functions.

To avoid the risks that are always present when you use an appliance, it is important that the appliance is installed correctly and that you read the safety instructions carefully to avoid misuse and hazards.

We recommend that you keep this instruction booklet for future reference and pass it on to any future owners.

This appliance complies with the requirements of Australian Standards AS/NZS 60335.2.6

IMPORTANT!

Check for any damage or marks

If you find the appliance is damaged or marked, you must report it within 7 days if you wish to claim for damage/marks under the manufacturer's warranty.

This does not affect your statutory rights.

INFORMATION ON DISPOSAL FOR USERS

ENVIRONMENT!

- Most of the packing materials are recyclable. Please dispose of those materials through your local recycling depot or by placing them in appropriate collection containers.
- If you wish to discard this appliance, please contact your local authorities and ask for the correct method of disposal.

IMPORTANT SAFETY INSTRUCTIONS

WARNING!

These warnings have been provided in the interest of safety. You MUST read them carefully before installing or using the appliance.

- An authorised person must install this appliance. (Certificate of Compliance to be retained)
- Before using the appliance, ensure that all packing materials are removed from the appliance.
- In order to avoid any potential hazard, the enclosed installation instructions must be followed.
- Ensure that all specified vents, openings and air spaces are not blocked.
- Where the appliance is built into a cabinet, the cabinet material must be capable of withstanding 70°C. If adjacent to vinyl-wrapped surfaces, use installation kit from vinyl wrap supplier.
- Only authorised personnel should carry out servicing. (Certificate of Compliance to be retained)
- Always ensure the appliance is switched off before cleaning or replacing parts.
- Do not open the oven door during steam cooking. Steam can be released. There is a risk of skin burns. There is a risk that steam causes moisture damage to cabinets.
- Allow the oven to cool down for 30mins before you drain the water tank in a steam oven. Scalding water may be released.
- In order to avoid fire, the appliance must be kept clean and vents kept unobstructed
- Do not spray flammable materials in or under the appliance, e.g. aerosols.
- Always use gloves when handling hot items inside the oven.
- Always turn the grill off immediately after use as fat left behind may catch fire.
- Do not cover the grill insert with foil, as fat left there may catch fire.
- Always keep the grill dish clean as any fat residue may catch fire.
- Do not leave the grill on unattended.
- To avoid fire, ensure that the grill trays and fittings are always inserted into the appliance in accordance with the instructions.
- Switch the appliance off before removing the oven light glass for globe replacement.
- To avoid an accident, ensure that the oven shelves and fittings are always inserted into the appliance in accordance with the instructions.
- **This appliance must be earthed.**

IMPORTANT SAFETY INSTRUCTIONS

Child safety

- This appliance is not intended for use by persons (including children) with reduced physical, sensory or mental capabilities, or lack of experience and knowledge, unless they have been given supervision or instruction concerning use of the appliance by a person responsible for their safety.
- Children should be supervised to ensure that they do not play with the appliance.
- During use this appliance becomes hot. Care should be taken to avoid touching hot surfaces, e.g. oven door, heating elements.
- Accessible parts will also become hot when in use. To avoid burns and scalds children should be kept away.

GENERAL CAUTIONS









Read the following carefully to avoid damage or injury

 **This symbol indicates never to do this**

 **This symbol indicates always do this**

It is important to use the appliance safely.

Check these safety points before using the appliance.

	This appliance must not be used as a space heater.
	Do not place thick portions of food under the grill. Foods may curl, catch and ignite.
	Do not use the door as a shelf.
	Do not push down on the open oven door.
	New appliances can have an odour during the first operation. It is recommended to 'run in' the oven before you cook. Run the oven at 180°C for 2 hours and ensure the room is well ventilated.
	Do not use harsh abrasive cleaners or sharp metal scrapers to clean the oven door glass since they can scratch the surface, and may result in shattering of the glass.
	Do not use steam cleaners, as this may cause moisture build-up.
	Always clean the appliance immediately after any food spills.



WARNING!

To maintain safe operation, it is recommended that the product be inspected every five years by an authorised service person.



ENVIRONMENT!

To save energy and to help protect the environment, we recommend these hints:

- Use the oven efficiently, by cooking many trays of food at the same time. Cook 2 trays of scones, small cakes or sausage rolls at the same time.
- Select the correct shelf location for food being cooked.
- Do not open the oven door more than necessary.

Note: You must read these warnings carefully before installing or using the appliance. If you need assistance, contact your Customer Care Centre. The manufacturer will not accept liability, should these instructions or any other safety instructions incorporated in this book be ignored.

IDENTIFYING THE APPLIANCE

Confirm the model number. The model number is shown on the data plate which is visible when the oven or grill door is open.



Control panel used on:

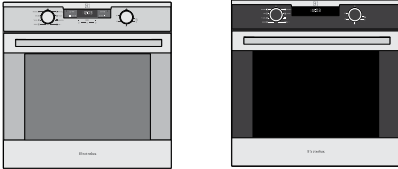

EVE611SA

EVE614BA

See page 6



Control panel used on:

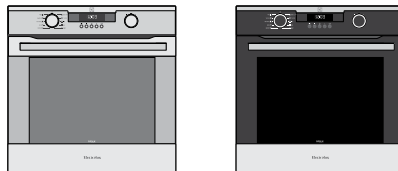

EVEP611SA

EVEP614BA

See page 14

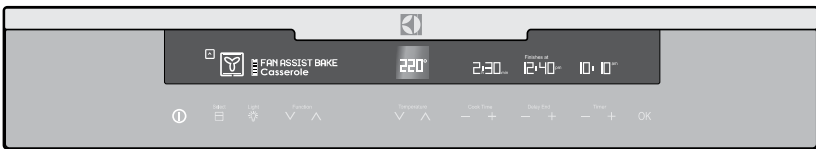

Control panel used on:



EVE613SA

EVE616BA

EVE623SA

EVE633SA

See page 23

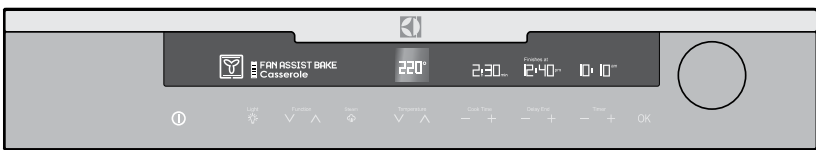

Control panel used on:

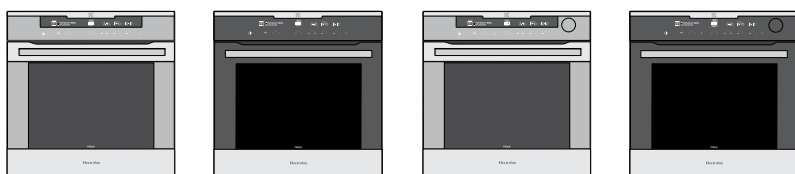

EVEP613SA

EVEP616BA

EVEP615SA

EVEP618BA

See page 33

EVE611SA, EVE614BA COMPONENTS

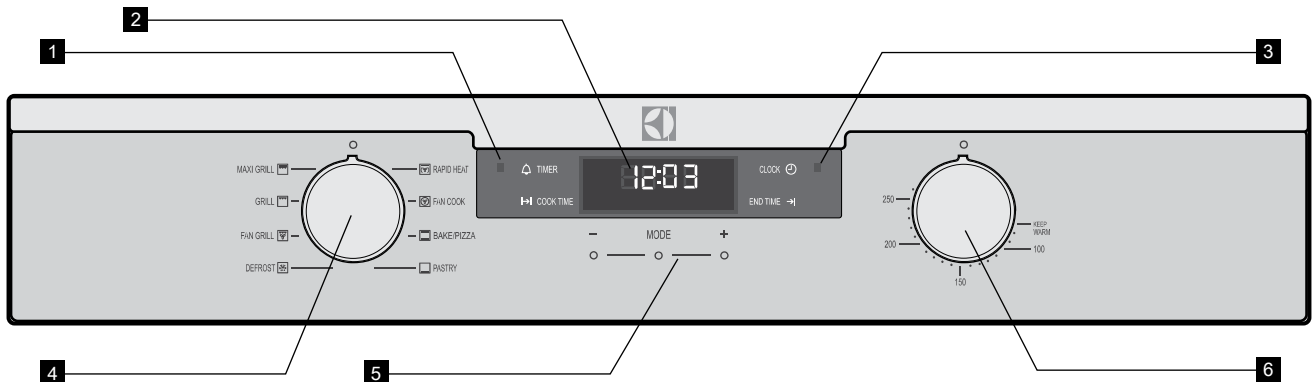

- 1 Oven 'ON' light
- 4 Function selector knob
- 2 Timer display
- 5 Touch pad
- 3 'Heating' light
- 6 Temperature selector knob

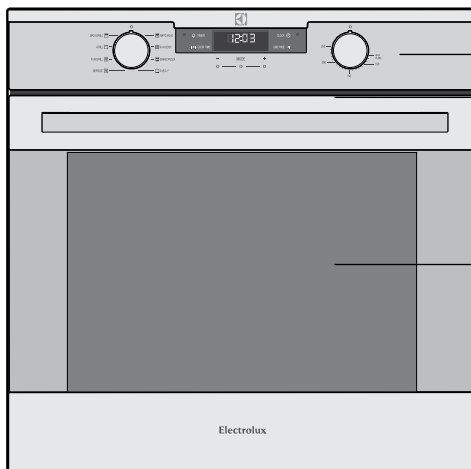

EVE611SA
stainless steel model

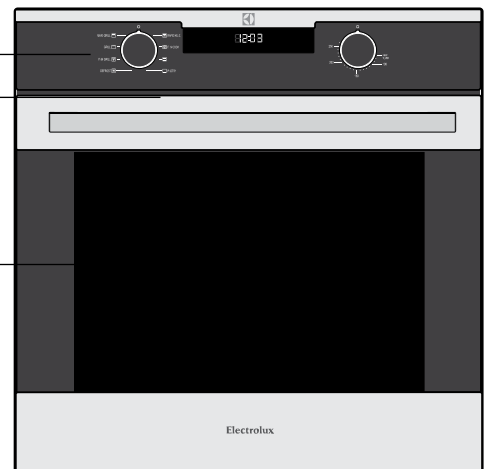

EVE614BA
black model

- 7 Control panel
- 9 Triple glazed door
- 8 Warm air exhaust

BEFORE USING THE APPLIANCE

Preparing the oven

1. Please remove all stickers, leaflets and boxes from the door and from the floor of the oven before operation.
2. Please wipe out the oven interior prior to operation with warm soapy water and polish dry with a soft clean cloth. Do not close the oven door until the oven is completely dry.
3. Do not line the oven with foil. It will damage the enamel.

Setting the time

Before the appliance can be used, the time must be set.

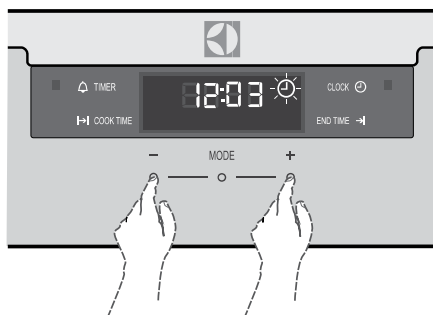

- After the appliance has been electrically connected '12:00' will be displayed and the ⌚ clock icon will flash.
- To set the time of day in hours and minutes touch the + or - symbols. Refer to the diagram above.
- 5 seconds after the last change, the clock 'symbol will disappear, confirming the time has been set. Once the time has been entered, the clock advances minute by minute.

Note: The clock has a 24 hour display.

i IMPORTANT!

New appliances can have a smell during first use. It is recommended to 'run in' the oven before cooking for the first time. Operate the oven, empty, at a temperature of 180°C for approximately 2 hours. Please ensure the room is well ventilated during this process.

Installing the oven accessories

• Catalytic liners

The oven will arrive with a catalytic fan baffle and top panel already fitted. Optional side panels are also supplied and may be fitted before installing the side racks. The sole purpose of the side panels is to make cleaning the oven easier. Omitting them will have no effect on the cooking performance of the oven. They can be fitted at any time by removing the side racks.

The catalytic liners supplied attach to the left and right sides of the oven. Please note that there is a different version for each side. They are marked 'LH' or 'RH'.

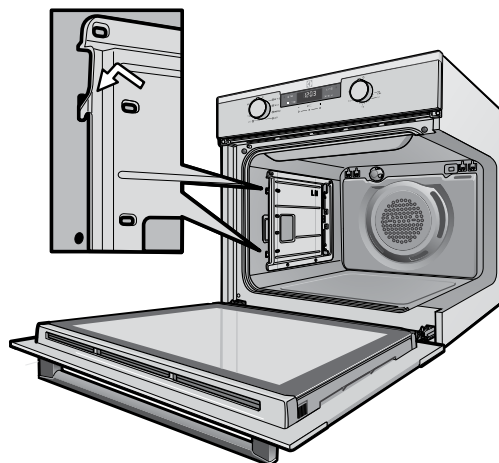

1. Position the first liner as per the diagram. The black, shiny side of the liner should be facing the oven wall with the hooks pointing down. Note that the diagram shows the left hand liner. The right hand side will be a mirror image of this.
2. Line the hooks up with the slots provided in the oven wall, push them in and then allow the liner to slide down to its final position. All four hooks MUST be engaged in the slots.
3. The access hole for the side racks should be visible when the liner is correctly positioned – see diagram.

• Side racks

1. Insert the twin pegged side into the rear access holes provided, ensuring pegs are fully inserted.
2. Then locate the front peg into the front access hole and push in firmly.

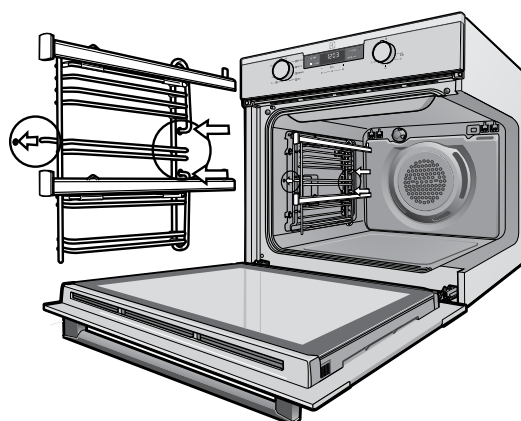

BEFORE USING THE APPLIANCE

• Shelves and trays

The shelves are designed so that they have maximum extension but cannot be accidentally pulled right out. The trays are designed the same way and slot straight into the side racks.

To fit a shelf or tray to side racks:

1. Locate the rear edge of the shelf/tray in between the guide rails of the side rack – see diagram. Ensure the same rail positions on both sides of the oven are being engaged.
2. With the front edge raised, begin to slide the shelf into the oven.
3. Once the detents have passed the front edge of the side rack, the shelf can be pushed completely in.
4. When fully inserted the shelf/tray should not interfere with the closed oven door.

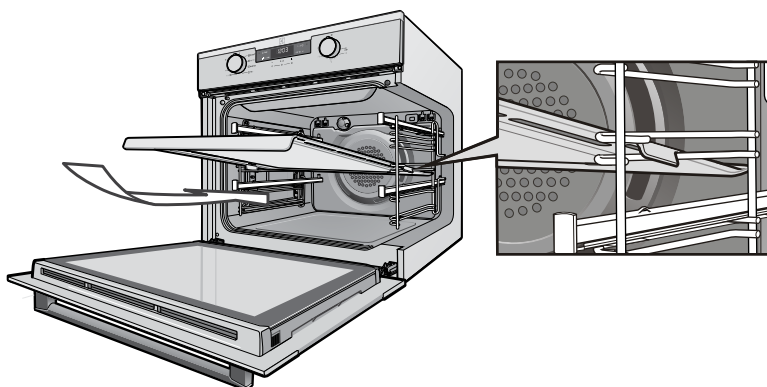





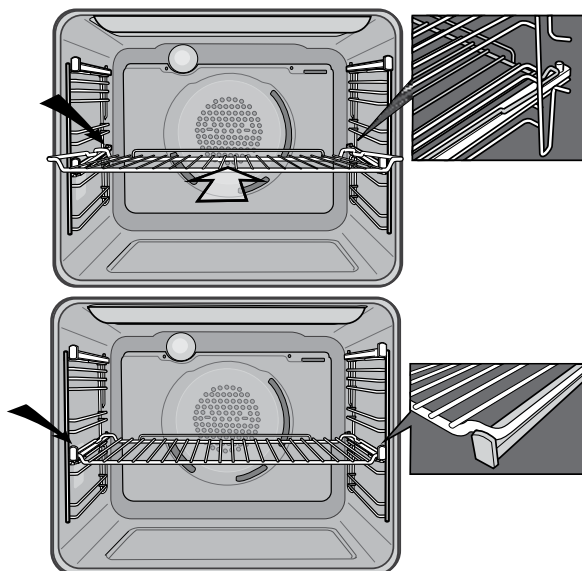



To fit a shelf or tray to telescopic slides:

1. With the slides fully pushed in, push the shelf or tray along the top of the slide until it hits the back post.
2. Drop the front of the shelf or tray onto the slide ensuring it sits behind the front post of the slide.
3. When fully inserted the shelf/tray should not interfere with the closed oven door.



COOKING FUNCTIONS

Symbol	Function description
Rapid heat 	Heat comes from the element surrounding the fan as well as the smaller element above the food. This allows you to preheat your oven 30% quicker than on standard 'Bake/Pizza'. 'Rapid Heat' is ideal for cooking frozen pre-cooked foods such as savoury pastries, pizzas, mini meals (TV dinners), meat pies and fruit pies. Simply place the food in the oven straight from the freezer and heat. Cook in the upper half of the oven for best results.
Fan cook 	Heat comes from the element surrounding the fan. This fan circulates the hot air around the oven cavity so that you can put your food in different places in the oven and still cook them at the same time. You can use 'Fan cook' function for multi-shelf cooking, reheating cooked foods, pastries and complete oven meals. It will cook at a lower temperature and be faster than baking. Please note that some variation in browning is normal.
Bake/pizza 	Heat comes from two elements, one above and one below the food. The bottom element is a clean heat element and is below the floor of the oven. Both elements are controlled by the thermostat and will turn on and off to maintain set temperature. You can use the 'Bake/pizza' function for single trays of biscuits, scones, muffins, cakes, slices, casseroles, baked puddings, roasts and delicate egg dishes.
Pastry 	Heat comes from the clean heat element below the food. The element is controlled by the thermostat and will turn on and off to maintain the set temperature. The 'Pastry' function can be used to add extra browning to the bases of pizzas, pies, and pastries. Cook in the lower half of the oven when you are using only one shelf.
Defrost 	The 'Defrost' function uses low temperature air that is circulated by the fan. You can defrost (thaw) your food before you cook it. You can also use 'Defrost' to raise your yeast dough and to dry fruit, vegetables and herbs.
Fan Grill 	<p>'Fan Grill' offers you the benefits of both 'Fan Cook' and traditional 'Grill' functions. The grill element turns on and off to maintain set temperature while the fan circulates the heated air.</p> <p>Fan grill with the oven door closed.</p> <p>You can use 'Fan Grill' for large cuts of meat, which gives you a result that is similar to 'roisserie' cooked meat. Put your food on a shelf in the second lowest shelf position. Put your grill dish on the lowest shelf to catch any spills. When using 'Fan Grill' it is not necessary to turn food over during the cooking cycle. Set temperature to 180°C.</p>
Grill 	<p>'Grill' function directs radiant heat from the powerful upper element onto the food. You can use the 'Grill' function for tender cuts of meat steak, chops, sausages, fish, cheese toasties and other quick cooking foods.</p> <p>Grill with the oven door closed.</p> <p>Preheat your grill for 3 minutes to get the best results. This will help seal in the natural juices of steak, chops etc for better flavour. You can slide your grill dish into either of the 2 spaces within the upper pairs of support rails.</p>
Maxi Grill 	<p>'Maxi Grill' directs radiant heat from 2 powerful upper elements onto the food. You can use the 'Maxi Grill' function for tender cuts of meat, steak, chops, sausages, fish, cheese toasties and other quick cooking foods.</p> <p>Grill with the oven door closed.</p> <p>'Maxi Grill' allows you to take full advantage of the large grill dish area and will cook faster than normal 'Grill'. For best results it is recommended to preheat your grill for 3 minutes. This will help seal in the natural juices of steak, chops etc for a better flavour. You can slide your grill dish into either of the 2 spaces within the upper pairs of support rails.</p>

OPERATING SEQUENCE

Select the cooking function

- Turn the function selector in any direction to the desired cooking function. The oven cavity light will come on.

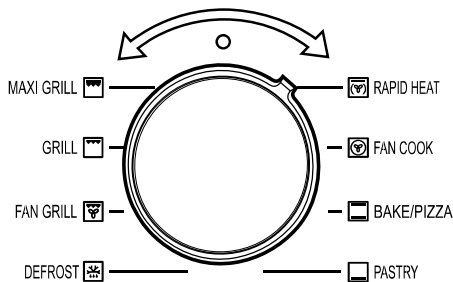

Select the temperature

- To set the temperature, turn the temperature selector in a clockwise direction to the desired setting. An indicator light in the display will come on.
- A thermostat controls the temperature in your oven. When the temperature is reached, the heating source switches itself off and the indicator light goes out. When the oven temperature falls below the desired setting, the heating source switches on and the indicator light comes on again.
- Once the food is cooked, turn the temperature selector back in an anti-clockwise direction. Do not force it right round in a clockwise direction as this will result in damage to the thermostat.

Note: The desired cooking function must be selected before the oven will operate.

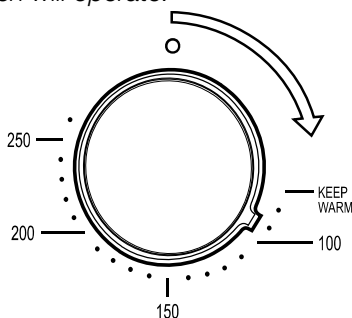

i IMPORTANT!

Pre-heating

For best cooking results pre-heat the oven. Pre-heating allows the oven to reach the required temperature quickly and efficiently as well as cook food at the correct temperature for the entire cook time.

1. With 'Rapid Heat' function

This function allows the oven to reach preset temperature quicker than any other cooking function. Turn the function selector to 'Rapid Heat', then set the desired temperature, by rotating the oven temperature selector.

When the heating light goes out, the oven has reached the desired temperature. Select the oven function required and place the food in the oven.

2. With other oven functions

Set the desired temperature by rotating your oven temperature selector. When the indicator light goes out the oven has reached the desired preset temperature, place your food in the oven, close the door and set the timer if you desire.

3. With 'Grill' function

Pre-heat the grill for at least 3 minutes to obtain best results. This will help to seal the natural juices of steak, chops and other meats for a better flavour.

USING THE APPLIANCE

i IMPORTANT!

Cooling / Vent fan

The built-in appliance is fitted with a cooling fan. This prevents the kitchen cabinet from overheating and reduces the condensation inside the oven. It will operate whenever the oven is in use and blow warm air across the top of the oven door.

Note: If the oven is still hot from cooking, the cooling fan will keep running to cool the oven down and will switch off by itself once cool.

Condensation

- Excess condensation may fog the oven door. This may happen when cooking large quantities of food from a cold start. Minimise condensation by:
 - Keeping the amount of water used whilst cooking to a minimum.
 - Making sure the oven door is firmly closed.
 - Baking custard in a baking dish that is slightly smaller than the water container.
 - Cooking casseroles with the lid on.

Note: If using water in cooking, this will turn to steam and may condense outside your appliance. This is not a problem or fault with your oven.

Cooking with the timer

The appliance is equipped with a timer that has the following features:

- Timer – sets a countdown time that will beep when the set time has elapsed.
- Cook time – sets cooking duration. A timer will count down the preset cooking time, beep when the time has elapsed and turn the appliance off.
- End time – instead of setting a cooking duration, a cooking finish time can be set. When the finish time has been reached the timer will beep and turn the appliance off.
- Delayed start cooking time – combines the cooking time and end cooking time to switch oven on and off at a specific time during the day.

Selecting the timer

- Touch the MODE symbol until the timer  icon begins flashing.
- Set the countdown time you want by using the **+** and **-** symbols. 5 seconds after the last change the timer 'icon will stop flashing and the countdown will start in minutes.
- To stop the beeper, touch any symbol.
- Maximum countdown time is 2hrs 30mins.

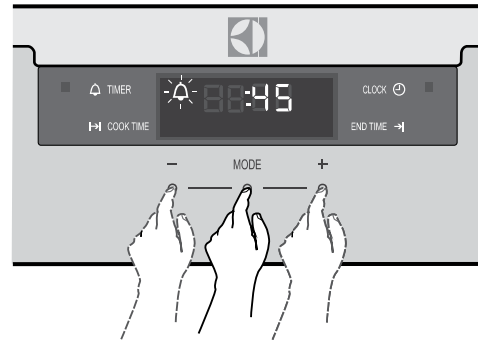

Setting the cooking duration

- Select the desired oven function and temperature.
- The oven indicator light will glow and the heating source will come on.
- Touch the MODE symbol until the cook time icon  begins flashing.
- Set the cooking duration you want by using the **+** and **-** symbols. Five seconds after the last change the cook time icon will stop flashing, and the time of day will be displayed. The oven will automatically shut off once the set duration is reached. To check how much time remains, press MODE until the cook time icon is lit. The remaining time will be displayed.
- When the oven shuts off an alarm will beep. To stop the beeper, touch any symbol.

Note: Remember to add pre-heating time if necessary.

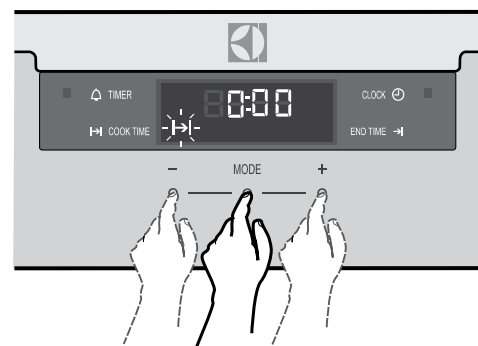

USING THE APPLIANCE

Setting the cooking end time

- Check that the clock displays the correct time of day.
- Select the desired oven function and temperature. The oven indicator light will glow and the heating source will come on.
- Touch the MODE Symbol until the end time →| icon begins flashing.
- Enter the time of day you want the cooking to finish by using the + and – symbols. Five seconds after the last change, the end time icon will stop flashing and the current time will be displayed.
- To stop the beeper, touch any symbol.



On completion of cooking

- The heat source will turn off, the timer will beep and the end time and/or cook time 'icons' will flash.
- Even though the heating element turns off the oven will still retain substantial heat. This will continue to cook the food until it is removed or the oven cools down. If you do not plan on being present when the oven turns off, you should take this extra heating time into account.
- Turn the function and temperature controls to the off position.
- Touch any button to stop the timer beeping.

Adjusting the clock

- Touch the MODE symbol until the ⌚ clock icon begins flashing.
- Touch the + and – symbols to change the time of day. 5 seconds after the last change, the clock icon will disappear, confirming the time has been adjusted.

Setting the delayed start cooking time

- Set the cook time and end time as described in the previous sections.
- Once both the cook time and end time have been set, both icons will stop flashing and the current time will be displayed.
- To check or cancel settings:
 - To check settings, touch the MODE symbol until the desired setting is displayed. The relevant icon will flash.
 - To cancel 'delayed start' touch the MODE symbol until the end time →| icon flashes. Touch and hold the – symbol until the clock no longer reverses (a beep will be heard). If temperature and function knobs are still at a setting, the oven will start once the end time →| icon stops flashing.
- To cancel 'auto shut off' touch the MODE symbol until the cook time |→| icon flashes. Touch and hold the – button until the clock no longer reverses (at 0:00 a beep will be heard). This automatically cancels 'auto shut off'. If the temperature and function knobs are still at a setting, the oven will start once the cook time |→| icon stops flashing. Because 'auto off' is cancelled the oven will continue to heat until it is manually turned off.

GETTING TO KNOW THE OVEN

Get to know your new oven with this 'Simple Test Cake'

Although we strive for a perfect performing oven, it's possible that there will be some variation in colour when baking. Therefore, we suggest this simple, easy and delicious to make Simple Test Cake, it can help you understand your new oven. All ovens do sometimes have hot or cold spots, therefore it is important to judge with your eye as you may require to rotate during baking.

'Simple Test Cake'

125g butter, softened to room temperature
 1 cup caster sugar
 1 teaspoon pure vanilla essence
 4 large eggs
 2 cups self-raising flour
 pinch of salt
 4 tablespoons (80mL) full-cream milk

Method:

1. Butter base and sides of two, 20cm straight-sided round or square cake pans. Then line the base with grease proof or baking paper.
2. Preheat oven to moderate '180°C' (170°C fan forced) and ensure oven shelf is in the centre position of oven.
3. Cream softened butter and sugar until light in colour.
4. Add vanilla essence.
5. Then eggs one at a time, beating well after each addition.
6. Sift flour and salt into the mixture and beat until well combined.
7. Add milk and beat or stir to combine.
8. Spoon mixture equally between prepared cake pans.
9. Bake in preheated oven, middle shelf for about 25 to 35 minutes or until when tested with a fine cake skewer it comes out clean or the edges of the cakes have come away slightly from the sides of the cake pans.
10. Remove from oven to wire cake rack and rest for 5 minutes before removing from cake pans.

Cool completely.

To Serve: sandwich together with your favourite jam or conserve, and dust top with pure icing sugar.

NOTE: if desired substitute butter for either margarine or olive oil spread. Recipe is based on the Australian standard metric 250mL cup and 20mL tablespoon sets.

EVEP611SA, EVEP614BA COMPONENTS

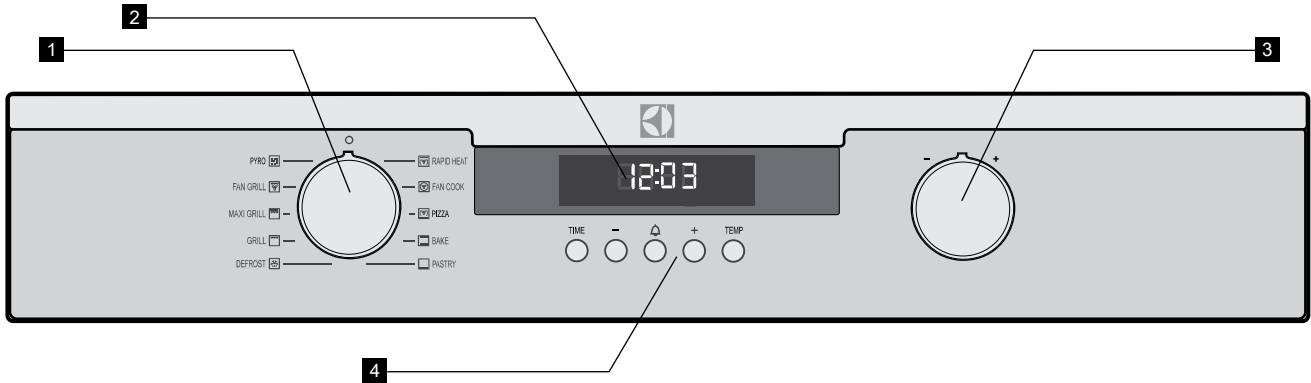

- 1** Function selector knob
- 2** Timer display

- 3** Temperature selector knob
- 4** 5 Button Controller

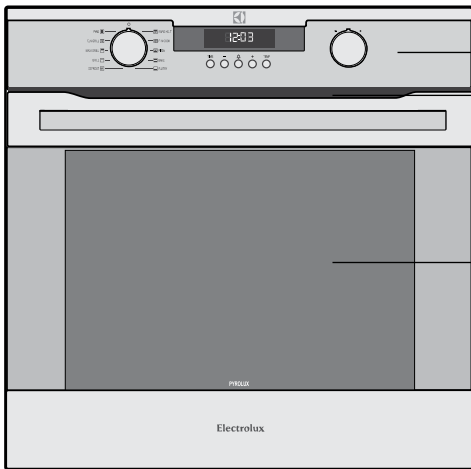

EVEP611SA
stainless steel model

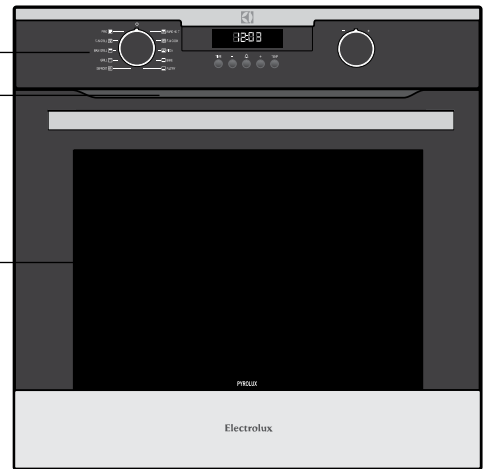

EVEP614BA
black model

- 5** Control panel
- 6** Warm air exhaust

- 7** Quad glazed door

BEFORE USING THE APPLIANCE

Preparing your oven

1. Please remove all stickers, leaflets and boxes from the door and from the floor of the oven before operation.
2. Please wipe out the oven interior prior to operation with warm soapy water and polish dry with a soft clean cloth. Do not close the oven door until the oven is completely dry.
3. Do not line the oven with foil. It will damage the enamel.

Setting the time

When power is supplied to the oven the  clock icon will be displayed. Along with the clock symbol the '12' will be flashing. This indicates that 'hour' portion of the time is ready to be changed.

- Press **+** or **-**, then press 'TIME' when you have the right hour.
- The minutes will flash and can be set in the same manner.
- 5 seconds after the last change, the clock display will stop flashing, confirming that the time has been set.

Note: The clock has a 24 hour display.

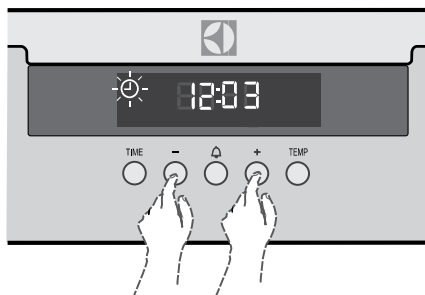

IMPORTANT!

New appliances can have a smell during first use. It is recommended to 'run in' the oven before cooking for the first time. Operate the oven, empty, at a temperature of 180°C for approximately 2 hours.

Please ensure the room is well ventilated during this process.

Installing your oven accessories

• Side racks

1. Insert the twin pegged side into the rear access holes provided, ensuring pegs are fully inserted.
2. Then locate the front peg into the front access hole and push in firmly.

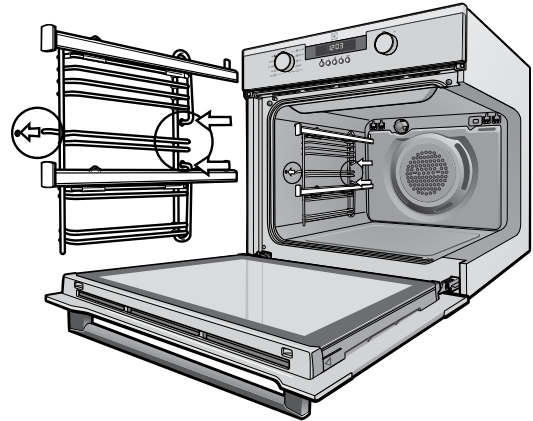

• Shelves and trays

The shelves are designed so that they have maximum extension but cannot be accidentally pulled right out. The trays are designed the same way and slot straight into the side racks.

To fit a shelf or tray to side racks:

1. Locate the rear edge of the shelf/tray in between the guide rails of the side rack – see diagram. Ensure the same rail positions on both sides of the oven are being engaged.
2. With the front edge raised, begin to slide the shelf into the oven.
3. Once the detents have passed the front edge of the side rack, the shelf can be pushed completely in.
4. When fully inserted the shelf/tray should not interfere with the closed oven door.

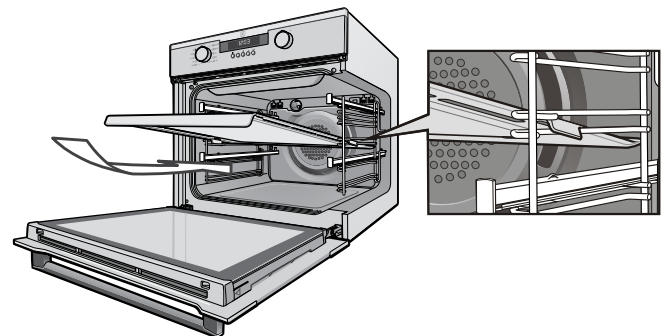







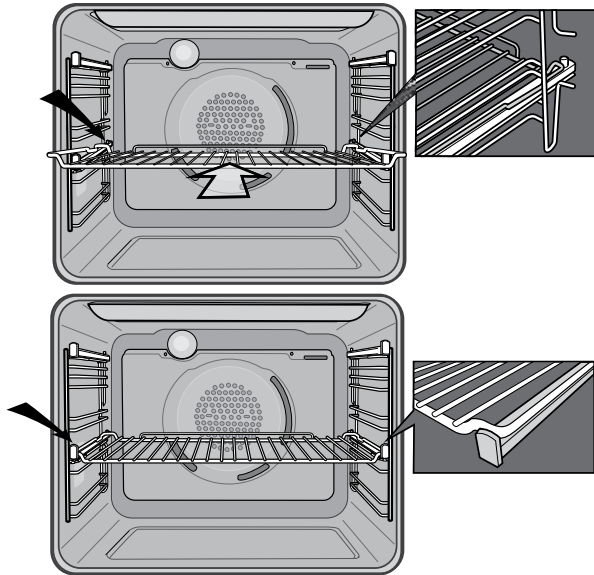



BEFORE USING THE APPLIANCE

To fit a shelf or tray to telescopic slides:

1. With the slides fully pushed in, push the shelf or tray along the top of the slide until it hits the back post.
2. Drop the front of the shelf or tray onto the slide ensuring it sits behind the front post of the slide.
3. When fully inserted the shelf/tray should not interfere with the closed oven door



COOKING FUNCTIONS

Symbol	Function description
Rapid heat 	Heat comes from the element surrounding the fan as well as the smaller element above the food. This allows you to preheat your oven 30% quicker than on standard 'Bake'. 'Rapid Heat' is ideal for cooking frozen pre-cooked foods such as savoury pastries, pizzas, mini meals (TV dinners), meat pies and fruit pies. Simply place the food in the oven straight from the freezer and heat. Cook in the upper half of the oven for best results.
Fan cook 	Heat comes from the element surrounding the fan. This fan circulates the hot air around the oven cavity so that you can put your food in different places in the oven and still cook them at the same time. You can use 'Fan cook' function for multi-shelf cooking, reheating cooked foods, pastries and complete oven meals. It will cook at a lower temperature and be faster than baking. Please note that some variation in browning is normal.
Pizza 	'Pizza' is a combination of 'Pastry' and 'Fan Cook' and offers you the combined benefits of both functions. Heat comes from the element surrounding the fan as well as the clean heat element below the oven floor. The 'pizza' function is ideal for foods that require cooking and browning of the base. It is great for foods such as pizzas, quiches, meat pies and fruit pies. Simply put the food in the middle of the oven and select the desired temperature.
Bake 	Heat comes from two elements, one above and one below the food. The bottom element is a clean heat element and is below the floor of the oven. Both elements are controlled by the thermostat and will turn on and off to maintain set temperature. You can use the 'Bake' function for single trays of biscuits, scones, muffins, cakes, slices, casseroles, baked puddings, roasts and delicate egg dishes.
Pastry 	Heat comes from the clean heat element below the food. The element is controlled by the thermostat and will turn on and off to maintain the set temperature. The 'Pastry' function can be used to add extra browning to the bases of pizzas, pies, and pastries. Cook in the lower half of the oven when you are using only one shelf.
Defrost 	The 'Defrost' function uses low temperature air that is circulated by the fan. You can defrost (thaw) your food before you cook it. You can also use 'Defrost' to raise your yeast dough and to dry fruit, vegetables and herbs.
Grill 	<p>'Grill' function directs radiant heat from the powerful upper element onto the food. You can use the 'Grill' function for tender cuts of meat steak, chops, sausages, fish, cheese toasties and other quick cooking foods.</p> <p>Grill with the oven door closed.</p> <p>Preheat your grill for 3 minutes to get the best results. This will help seal in the natural juices of steak, chops etc for better flavour. You can slide your grill dish into either of the 2 spaces within the uppers pairs of support rails.</p>
Maxi Grill 	<p>'Maxi Grill' directs radiant heat from 2 powerful upper elements onto the food. You can use the 'Maxi Grill' function for tender cuts of meat, steak, chops, sausages, fish, cheese toasties and other quick cooking foods.</p> <p>Grill with the oven door closed.</p> <p>'Maxi Grill' allows you to take full advantage of the large grill dish area and will cook faster than normal 'Grill'. For best results it is recommended to preheat your grill for 3 minutes. This will help seal in the natural juices of steak, chops etc for a better flavour. You can slide your grill dish into either of the 2 spaces within the upper pairs of support rails.</p>
Fan Grill 	<p>'Fan Grill' offers you the benefits of both 'Bake' and traditional 'Grill' functions. The grill element turns on and off to maintain set temperature while the fan circulates the heated air.</p> <p>Fan grill with the oven door closed.</p> <p>You can use 'Fan Grill' for large cuts of meat, which gives you a result that is similar to 'rotisserie' cooked meat. Put your food on a shelf in the second lowest shelf position. Put your grill dish on the lowest shelf to catch any spills. When using 'Fan Grill' it is not necessary to turn food over during the cooking cycle. Set temperature to 180°C.</p>
Pyro 	The 'pyrolytic cleaning' function cleans by burning off the spatters and accumulated dirt and grease from the oven liner, at high temperature. This process produces ash which can be wiped out of the oven cavity.

OPERATING SEQUENCE

Select the oven function

- Turn the oven function selector clockwise to select the desired oven function.

Note: each oven function has a default temperature which can then be adjusted as outlined below.

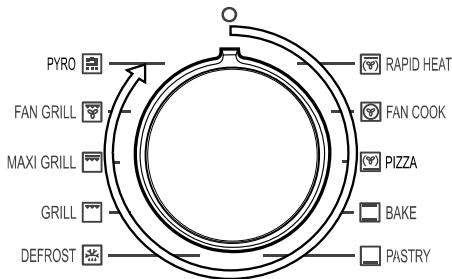

Selecting the oven temperature

- Toggle the temperature selector (left **-** or right **+**) as required to set the desired cooking temperature in °C.

Note: the temperature can be adjusted at any time throughout the cooking time.

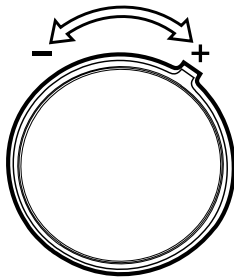

i IMPORTANT!

Pre-heating

For best cooking results, pre-heat the oven. Pre-heating allows the oven to reach the required temperature quickly and efficiently as well as cook food at the correct temperature for the entire cook time.

1. With 'Rapid Heat' function

This function allows the oven to reach preset temperature quicker than any other cooking function. Turn the function selector to 'Rapid Heat', then set the desired temperature, by rotating the oven temperature selector. When the heating light goes out, the oven has reached the desired temperature. Select the oven function required and place the food in the oven.

2. With other oven functions

Set the desired temperature by rotating the oven temperature selector. When the indicator light goes out the oven has reached the desired preset temperature, place the food in the oven, close the door and set the timer if you desire.

3. With 'Grill' function

Pre-heat the grill for at least 3 minutes to obtain best results. This will help to seal the natural juices of steak, chops and other meats for a better flavour.

i IMPORTANT!

Cooling / Vent fan

The appliance is fitted with a cooling fan. This prevents the kitchen cabinet from overheating and reduces the condensation inside the oven. It will operate whenever the oven is in use and blow warm air across the top of the oven door.

Note: If the oven is still hot from cooking, the cooling fan will keep running to cool the oven down and will switch off by itself once cool.

Condensation

Excess condensation may fog the oven door. This may happen when cooking large quantities of food from a cold start. Minimise condensation by:

- Keeping the amount of water used whilst cooking to a minimum.
- Making sure the oven door is firmly closed.
- Baking custard in a baking dish that is slightly smaller than the water container.
- Cooking casseroles with the lid on.

Note: If using water in cooking, this will turn to steam and may condense outside the appliance. This is not a problem or fault with the oven.

USING THE APPLIANCE

Cooking with the timer

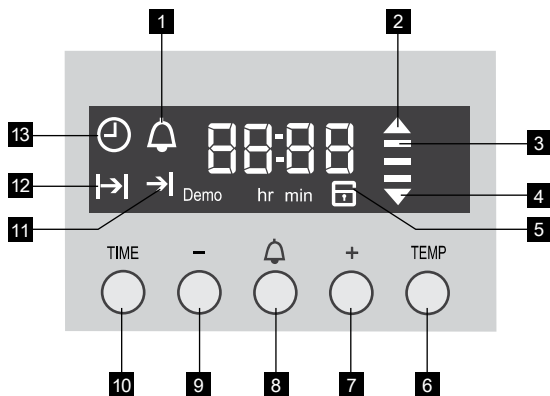

- 1 On when the timer is set
- 2 On when oven warming up
- 3 3 bars displayed when oven reaches set temperature
- 4 On when oven cooling down
- 5 Oven door locked
- 6 Press to display current oven temperature
- 7 Press to increase hours/mins
- 8 Press to start timer mode.
Hold to turn oven light on/off.
- 9 Press to decrease hours/mins
- 10 Press to toggle through the timer modes
- 11 End time icon
- 12 Cook time icon
- 13 Time of day icon

Adjusting the clock



To change the time, press and hold the 'TIME' button  until the clock symbol begins to flash. The hour display will be ready to change.

- Press **+** or **-**, then press 'TIME' when you have the right hour.
- The minutes will flash and can be set in the same manner.
- 5 seconds after the last change, the clock display will stop flashing, confirming that the time has been set.

Note: The clock has a 24 hour display.



The timer can be used to turn the oven off in two ways by setting the cooking time (duration) or by setting the end time (time of day you want the oven off).

Setting the cook time

1. Use the knobs to select the desired oven function and cooking temperature.
2. Press the 'TIME' button as often as necessary, until the 'cook time'  symbol appears.
3. Set the desired cooking time commencing with minutes by using the **+** or **-** buttons, whilst the  symbol is flashing, then press the 'TIME' button again and set the hours by using the **+** or **-** buttons. After 5 seconds from the last time adjustment the  symbol will stop flashing. The appliance is now programmed and the display will countdown to zero.
4. When the set time has elapsed, a signal will sound and the appliance will turn off. To stop the signal, press any button on the clock and then turn the oven function selector to OFF.

Note: Cooking time cannot be set for the Rapid Heat function. The feature can be cancelled at any time by returning the function selector to off.





Setting the end time

1. Use the knobs to select the desired oven function and cooking temperature.
2. Press the 'TIME' button as often as necessary, until the 'end time'  symbol appears.
3. Set the desired end time commencing with hours using the **+** or **-** buttons whilst the  symbol is flashing, then press the 'TIME' button again and set the minutes by using the **+** or **-** buttons. After 5 seconds from the last time adjustment the  symbol will stop flashing and the appliance is now programmed.
4. When the set time has elapsed, a signal will sound and the appliance will turn off. To stop the signal, press any button on the clock and then turn the oven function selector to OFF.

Note: Stop time cannot be set for the Rapid Heat function.

Setting the delayed start cooking time

The 'cook time' and 'end time' functions can be combined to switch the oven on and off at a specific time during the day.

1. Select the desired oven function and cooking temperature.
2. Press the 'TIME' button as often as necessary, until the 'cook time'  symbol appears.
3. Set the desired cooking time by using **+** or **-** buttons, whilst the  symbol is flashing.
4. Press the 'TIME' button as often as necessary, until the 'end time'  symbol appears flashing
5. Set the desired switch-off time using the **+** or **-** whilst the 'end time'  symbol is flashing.
6. 5 seconds after the last change the 'cook time' and 'end time' arrows are lit to confirm that the oven has been programmed.
7. When the delayed start cooking time has elapsed, a signal will sound and the appliance will turn off. To stop the signal, press any button on the clock and then turn the oven function selector to OFF.



Note: Delayed start cooking time cannot be set for the Rapid Heat function. The feature can be cancelled at any time by returning the function selector to off.

USING THE APPLIANCE

Additional Functionality

Setting the countdown timer

Use this for timing any activity. For example boiling eggs.

1. Press the  button, the display will flash.
2. Set the countdown time you want by using **+** and **-**. Commence with setting the number of seconds first. The minutes and hours can then be set by subsequently pressing the  button again and adjusting using the **+** or **-** buttons. 5 seconds after the last change the timer will stop flashing, confirming the timer has been set.
3. To cancel the timer press the  button, the display will flash. Then press and hold **+** and **-** buttons until the timer is cleared.
4. To stop the beeper, press any button.

Note: The clock display cannot be selected when the timer is operating.

Elapsed Time

When an oven function is selected (other than pyrolytic clean) an elapsed timer commences on the display.



To reset this timer press and hold both the **+** and **-** buttons until the timer is reset.

Displaying the cavity temperature

During operation of the oven the current oven temperature during pre-heating of the oven can be displayed by pressing the TEMP button. During normal operation the set temperature can be reviewed by pressing the TEMP button.

Note: this temperature will only be displayed for approximately 5 seconds.

Light operation

During operation of the oven the light can be switched off by pressing and holding the  button until the light turns off. Also the light can be turned on from the standby state by pressing and holding the  button until the light comes on.

Activating the child-proof lock

When the child lock is engaged, the oven cannot be operated and the door cannot be opened

1. Switch off the appliance using the function selector switch.
2. Press and hold the TIME and **+** buttons at the same time until the word 'SAFE' is displayed and a double beep is sounded. The word safe will be replaced by a padlock symbol on the display after 5 seconds.

Releasing the child-proof lock

Press and hold the TIME and **+** buttons at the same time until a double beep is sounded. This will commence to unlock the door and after 5 seconds the oven is ready for use.

Switching the clock display ON and OFF

1. Press together **+** and **-** for 2 seconds to switch 'off' the display.
2. Press together **+** and **-** for 2 seconds to switch the clock display 'on' again.
3. When the display is set to the 'off' state pressing the **+** and **-** button momentarily will display the time for 5 seconds then turn off the display.
4. When the display is set to the 'off' state, turning on the oven will turn the display 'on' for the duration of oven operation. Once the function is turned 'off' the display will turn off after 5 seconds.

Note: if a timer mode is set or the oven is operating, then it is not possible to switch the display off.

Safety Cut-out feature

The oven automatically switches itself off if the temperature is not adjusted or the appliance is left operating after a period of time. The oven switches itself off after:

- 12.5 hours when the temperature is set less than 120°C.
- 8.5 hours when the temperature is set to 120°C or above, and below 200°C.
- 5.5 hours when the temperature is set to 200°C or above, and below 250°C
- 3.0 hours when the temperature is set at 250°C.

DEMO Mode

The oven can be set to operate in a demo mode (eg in a retail store). In this mode the display works and functions can be set but the oven does not actually heat. When in this mode the text 'DEMO' will be lit. The following instructions show how to enter and exit 'Demo' mode.

1. Ensure the oven is in the off state. Press and hold the **+** button until a beep sounds. The 'Demo' text will begin to flash.
2. While holding the **+** button turn the function selector to the first oven function until another beep is heard.
3. Then turn the function selector to the 'off' position.
4. Release the **+** button.
5. Toggle and hold the temperature selector to the right (**+**) until 3 beeps sound.

GETTING TO KNOW THE OVEN

Get to know your new oven with this 'Simple Test Cake'

Although we strive for a perfect performing oven, it's possible that there will be some variation in colour when baking. Therefore, we suggest this simple, easy and delicious to make Simple Test Cake, it can help you understand your new oven. All ovens do sometimes have hot or cold spots, therefore it is important to judge with your eye as you may require to rotate during baking.

'Simple Test Cake'

125g butter, softened to room temperature
 1 cup caster sugar
 1 teaspoon pure vanilla essence
 4 large eggs
 2 cups self-raising flour
 pinch of salt
 4 tablespoons (80mL) full-cream milk

Method:

1. Butter base and sides of two, 20cm straight-sided round or square cake pans. Then line the base with grease proof or baking paper.
2. Preheat oven to moderate '180°C' (170°C fan forced) and ensure oven shelf is in the centre position of oven.
3. Cream softened butter and sugar until light in colour.
4. Add vanilla essence.
5. Then eggs one at a time, beating well after each addition.
6. Sift flour and salt into the mixture and beat until well combined.
7. Add milk and beat or stir to combine.
8. Spoon mixture equally between prepared cake pans.
9. Bake in preheated oven, middle shelf for about 25 to 35 minutes or until when tested with a fine cake skewer it comes out clean or the edges of the cakes have come away slightly from the sides of the cake pans.
10. Remove from oven to wire cake rack and rest for 5 minutes before removing from cake pans.

Cool completely.

To Serve: sandwich together with your favourite jam or conserve, and dust top with pure icing sugar.

NOTE: if desired substitute butter for either margarine or olive oil spread. Recipe is based on the Australian standard metric 250mL cup and 20mL tablespoon sets.

CLEANING THE OVEN

Pyrolytic cleaning of the oven cavity

The oven has the Pyrolytic self-cleaning function, it cleans by burning off the spatters and accumulated dirt and grease from the oven liner, at high temperature. This process produces ash which can then be wiped out of the oven cavity.

! WARNING!

During the pyrolytic cleaning process the oven becomes extremely hot.

- Please keep small children at a safe distance.
- Never clean non-stick baking trays and tins in the oven during the pyrolytic cycle. High temperatures damage the non-stick coating and poisonous gas is released

! CAUTION!

- During pyrolytic cleaning the air outlet exhaust above the door must be kept clear of any obstruction (eg bulky tea towels).
- Do not use the oven to clean miscellaneous items (eg cookware).

Before carrying out the Pyrolytic function

1. All accessories must be removed from the oven, including shelves, trays and side racks.
2. Clean large deposits, spills or grease from the oven cavity.
3. Choose the Pyrolytic cleaning cycle from the following:

soiling	duration
light clean	1hr 30mins
normal clean	2hr 30mins

Note: Duration includes heat-up time and cool-down time.

• Light clean

This is an energy saving cycle that can be used on a regular basis if the oven is lightly soiled. Possibly after every 2nd or 3rd roast.

• Normal clean

Use this as the regular cycle about once every 2-3 months.

Pyrolytic Cleaning Operation

The pyrolytic cleaning function can be selected by turning the function selector switch clockwise to the pyrolytic position. Use the **+** or **-** buttons on the electronic clock to toggle between a pyrolytic cleaning time of 1:30 hours or 2:30 hours. The pyrolytic function can be stopped at any time by turning the function selector counterclockwise to the OFF position.

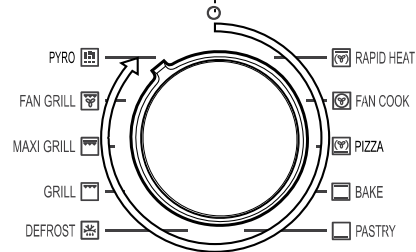

i IMPORTANT!

During Pyrolytic cleaning the door will automatically lock when the temperature in the oven approaches 300°C.  will appear on the display.

The door will only unlock when the oven has cooled to a safe temperature. Turning the function off will not unlock the door. This will only happen when safe temperatures are reached.

Note: The cooling fan will operate at an increased speed for Pyrolytic cleaning and will continue to run until the oven has cooled down. This is normal.

It is recommended to clean the oven regularly to keep it in its best condition.

After Pyrolytic cleaning

After cool-down, wipe the ash out of the oven with a soft damp cloth and warm water.

To restore the enamel shine to more difficult areas, use a damp cloth with vinegar and detergent.

! CAUTION!

Do not turn off the mains power supply to the oven during the pyrolytic cycle. This could damage the appliance

EVE613SA, EVE616BA COMPONENTS

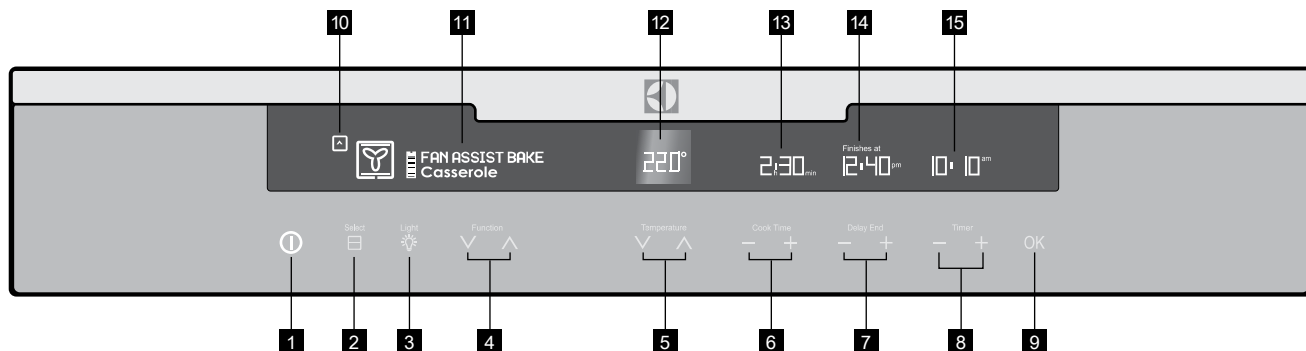

- | | | |
|--|--|------------------------------------|
| 1 ON/OFF | 6 Cook Time control | 11 Cooking function display |
| 2 Upper/Lower oven selector
(EVE623SA and EVE633SA only) | 7 Delay end control | 12 Temperature display |
| 3 Light on/off | 8 Set clock and timer control | 13 Cook time display |
| 4 Cooking function selector | 9 Instant confirm | 14 Delay end display |
| 5 Temperature control | 10 Oven cavity icon
(EVE623SA and EVE633SA only) | 15 Clock/timer display |

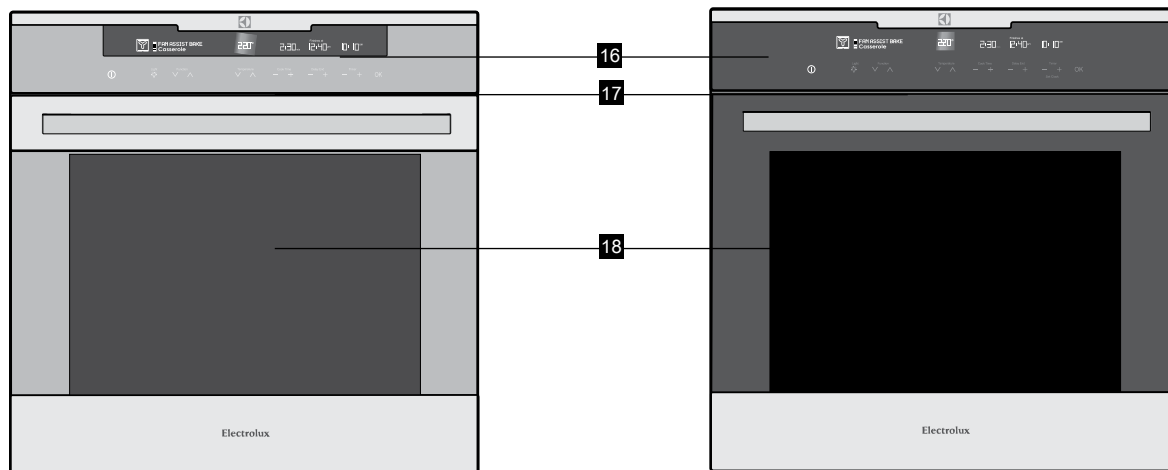

EVE613SA - single cavity stainless steel model

EVE616BA - single cavity black model

- 16** Control panel
- 17** Warm air exhaust
- 18** Triple glazed door

EVE623SA, EVE633SA COMPONENTS

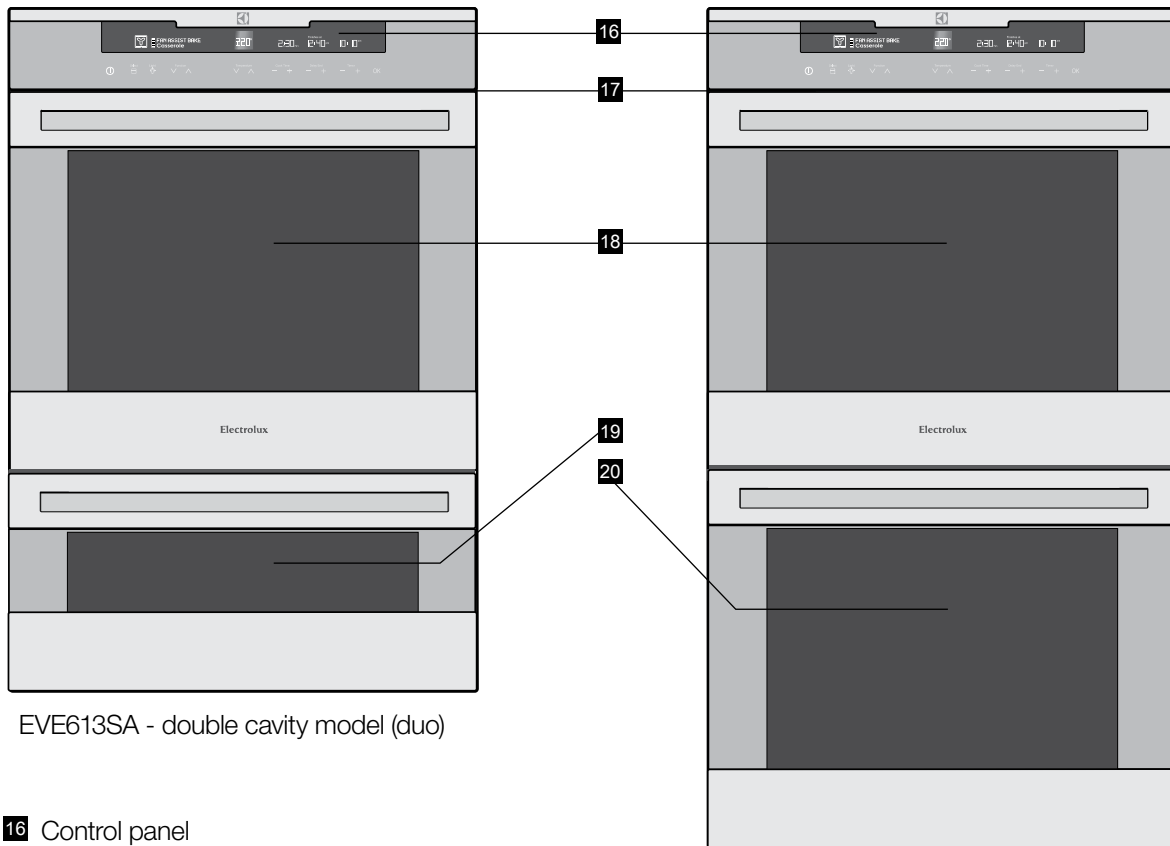

EVE613SA - double cavity model (duo)

EVE633SA - double cavity oven
(double wall oven)

- 16 Control panel
- 17 Warm air exhaust
- 18 Triple glazed door
- 18 Upper main oven with triple glazed door
- 19 Lower (half sized) oven with triple glazed door
- 20 Lower (full sized) oven with triple glazed door

BEFORE USING THE APPLIANCE

Preparing the appliance

1. Please remove all stickers, leaflets and boxes from the door and from the floor of the oven before operation.
2. Please wipe out the oven interior prior to operation with warm soapy water and polish dry with a soft clean cloth. Do not close the oven door until the oven is completely dry.
3. Do not line the oven with foil. It will damage the enamel.

Setting the time

The time of day must be set before the appliance can operate.

After the appliance has been electrically connected the display will cycle through the welcome screen, then 'Set Clock' will illuminate under the clock display and the Hour digits will flash.

1. Use the timer **+** and **-** to set the hour portion of the current time (including AM/PM).
2. Press OK when the hours are set correctly. The Minute digits will flash.
3. Use the timer **+** and **-** to set the minutes portion of the current time.
4. Press OK when the minutes are set correctly. You can turn the off the oven or it will do so after 8 seconds. Once the time has been entered, the clock advances minute by minute.

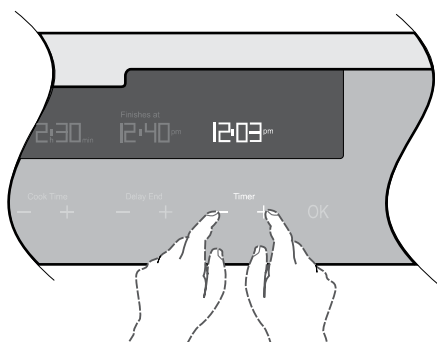

Note: The clock has a 12 hour display and will remember the time for 3 days without power.

Installing your oven accessories

• Catalytic liners

The oven will arrive with a catalytic fan baffle and top panel already fitted. Optional side panels are also supplied and may be fitted before installing the side racks. The sole purpose of the side panels is to make cleaning the oven easier. Omitting them will have no effect on the cooking performance of the oven. They can be fitted at any time by removing the side racks. The catalytic liners supplied attach to the left and right sides of the oven. Please note that there is a different version for each side. They are marked 'LH' or 'RH'

1. Position the first liner as per the diagram. The black, shiny side of the liner should be facing the oven wall with the hooks pointing down. Note that the diagram shows the left hand liner. The right hand side will be a mirror image of this.
2. Line the hooks up with the slots provided in the oven wall, push them in and then allow the liner to slide down to its final position. **All four hooks MUST be engaged in the slots.**
3. The access hole for the side racks should be visible when the liner is correctly positioned – see diagram.

The access hole for the side racks should be visible when the liner is correctly positioned – see diagram.

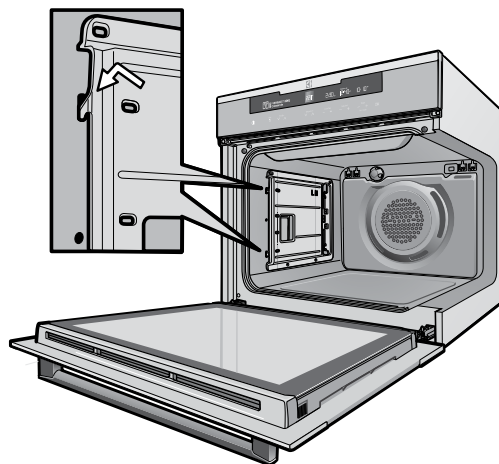

Note: If you have purchased an EVE623SA OR EVE633SA you will have additional catalytic liners for the extra oven cavity.

i IMPORTANT!

New appliances can have a smell during first use. It is recommended to 'run in' the oven before you cook for the first time. Operate the oven, empty, at a temperature of 180°C for approximately 2 hours. Please ensure the room is well ventilated during this process.

BEFORE USING THE APPLIANCE

• Side racks

1. Insert the twin pegged side into the rear access holes provided, ensuring pegs are fully inserted.
2. Then locate the front peg into the front access hole and push in firmly.

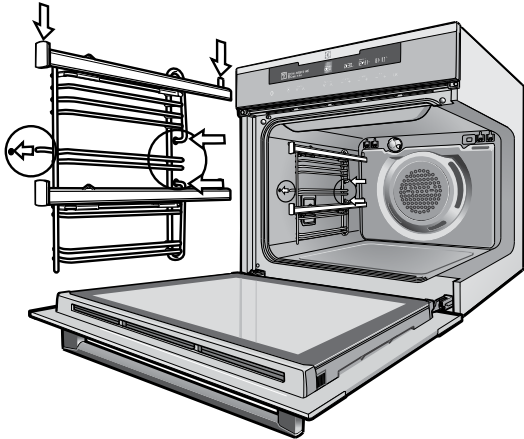

Note: If you have purchased an EVE623SA you will have additional side racks for the lower oven/grill. These are fitted in a similar manner, however the left hand side rack must be fitted to the lower two holes of the half cavity.

• Shelves and trays

The shelves are designed so that they have maximum extension but cannot be accidentally pulled right out. The trays are designed the same way and slot straight into the side racks.

To fit a shelf or tray to side racks:

1. Locate the rear edge of the shelf/tray in between the guide rails of the side rack – see diagram. Ensure the same rail positions on both sides of the oven are being engaged.
2. With the front edge raised, begin to slide the shelf into the oven.
3. Once the detents have passed the front edge of the side rack, the shelf can be pushed completely in.
4. When fully inserted the shelf/tray should not interfere with the closed oven door.

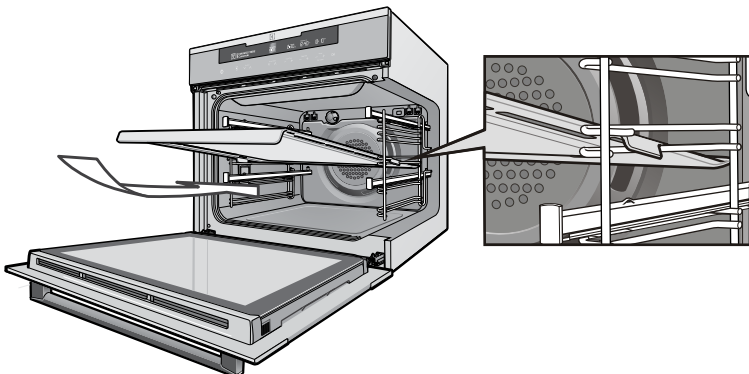





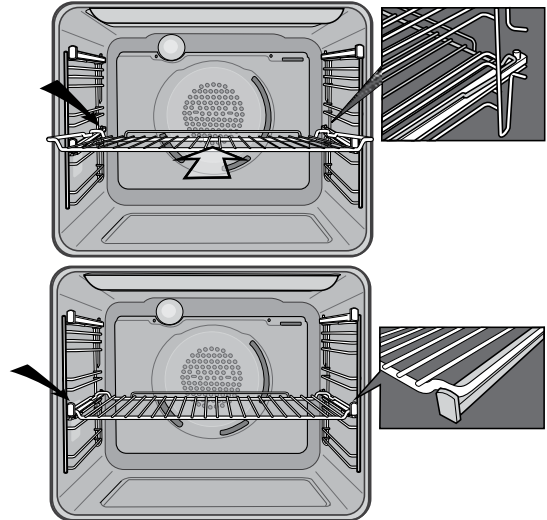







To fit a shelf or tray to telescopic slides:

1. With the slides fully pushed in, push the shelf or tray along the top of the slide until it hits the back post.
2. Drop the front of the shelf or tray onto the slide ensuring it sits behind the front post of the slide.
3. When fully inserted the shelf/tray should not interfere with the closed oven door.



COOKING FUNCTIONS

Symbol Function description

Fan cooking 	Heat comes from the element surrounding the fan. This fan circulates the hot air around the oven cavity so that you can put your food in different places in the oven and still cook them at the same time. You can use the 'Fan Cooking' function for multi-shelf cooking, reheating cooked foods, pastries and complete oven meals. It will cook at a lower temperature and be faster than baking. Please note that some variation in browning is normal.
Traditional bake 	Heat comes from two elements, one above and one below the food. The bottom element is a clean heat element and is below the floor of the oven. Both elements are controlled by the thermostat and will turn on and off to maintain set temperature. You can use the 'Traditional Bake' function for single shelf cooking, single trays of biscuits, scones, muffins, cakes, slices, casseroles, baked puddings, roasts and delicate egg dishes. This is a general function that can be used for most cooking.
Fan assist bake 	Heat comes from two elements, one above and one below the food. The fan circulates the hot air around the oven cavity so that you can put the food in different places in the oven and still cook them at the same time. You should only use a maximum of two shelves with 'Fan Assist Bake'. Do not use the bottom shelf. If the two shelves are used, food on the shelf in the higher position will cook first and should then be removed to allow the food on the lower shelf to finish cooking.
Roast 	This function starts at a higher temperature to seal the meat. The oven will then automatically reduce to the selected temperature to cook the meat for as long as desired. For example, if you use the default 200°C the 'Roast' cycle will start at 240°C and then lower to 200°C.
Pastry 	The 'Pastry' function is specially designed for food that require extra browning such as the bases of pastries and pies. Heat comes from the element below the food. If you choose the default setting, the oven will heat up to 230°C in order to brown the food. You should then lower the temperature as required. Cook in the lower half of the oven when you are using only one shelf.
Pizza 	'Pizza' is a combination of 'Pastry' and 'Fan Assist Bake' and offers you the combined benefits of both functions. Heat switches between the element surrounding the fan and the clean heat element below the oven floor. The 'Pizza' function is ideal for foods that require cooking and browning on the base. It is for foods such as pizzas, quiches, meat pies and fruit pies. Simply place the food in the middle of the oven and set the desired temperature.
Cook from frozen 	The 'Cook from Frozen' function is ideal for cooking frozen precooked foods such as savoury pastries, pizzas, mini meals (TV dinners), meat pies and fruit pies. Heat comes from the element surrounding the fan as well as a smaller element above the food. Simply place the food in the oven straight from the freezer and heat. Cook in the upper half of the oven for best results.
Full grill 	'Full Grill' direct radiant heat from two powerful upper elements onto the food. You can use 'Full Grill' function for tender cuts of meat, steak, chops, sausages, fish, cheese toasties and other quick cooking foods. Grill with the oven door closed. 'Full Grill' allows you to take full advantage of the large grill dish area and will cook faster than the 'Half Grill' function. For best results it is recommended to preheat your grill for three minutes. This will help seal in the natural juices of steak, chops etc for a better flavour. You can slide your grill dish into either of the two spaces within the upper pairs of support rails. Full Grill has 2 temperature settings, 'LO' and 'HI'.
Half grill 	The 'Half Grill' directs radiant heat from only one of the powerful upper elements onto the food. The 'Half Grill' function is used instead of 'Full Grill' when only half the amount of heat is needed. Half Grill has 2 temperature settings, 'LO' and 'HI'. Grill with the oven door closed.
Fan grill 	'Fan Grill' offers you the benefits of both traditional bake and traditional grill functions. The grill element turns on and off to maintain set temperature while the fan circulates the heated oven air. Grill with the oven door closed. You can use 'Fan Grill' for large cuts of meat, which gives you a result similar to 'rotisserie' cooked meat. Put your food on a shelf in the second lowest shelf position. Put the grill dish on the lowest shelf position to catch any spills. When using 'Fan Grill' it is not necessary to turn the food over during the cooking cycle. Set temperature to 180°C.
Keep warm 	The 'Keep Warm' function is a low temperature oven function designed to keep your food at a perfect eating temperature without cooking it further. Heat comes from the smaller elements above the food and is circulated by the fan. Use 'Keep Warm' to keep your food warm while you prepare the rest of the meal or afterwards while you wait for the late arrival.
Defrost 	The 'Defrost' function uses low temperature air that is circulated by the fan. You can defrost (thaw) your food before you cook it. You can also use 'defrost' to raise your yeast dough and to dry fruit, vegetables and herbs. The 'Defrost' function does not have a suggested temperature but uses the ambient heat in the oven cavity.

OPERATING SEQUENCE

Turning the oven on

- Switch on the oven by touching the **⏻** ON/OFF symbol. The control panel will come on and inform you that you need to select a cooking function.
- If you do not select a function within 20 seconds the oven will turn off.

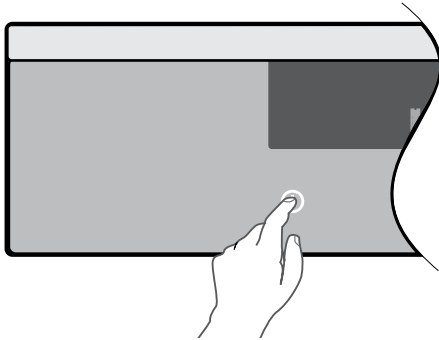

Selecting the Upper or Lower oven

(EVE623SA, EVE633SA)

These models are equipped with two ovens. Use the oven selector symbol to toggle between the upper and lower ovens.

The oven cavity icon on the control panel will show which oven is currently active.

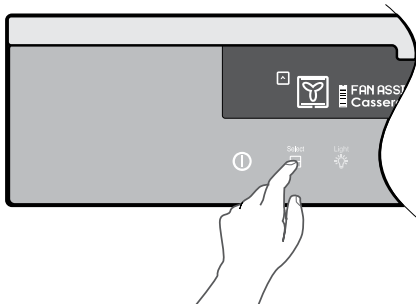

Select a cooking function

The oven will have a selection of functions. Press the function **▲** or function **▼** symbols as many times as necessary until the desired function appears.

Cooking suggestions will appear under the function name and suggested cooking temperatures will appear above the temperature selector.

If no other symbol is touched within 8 seconds the oven will switch on and begin to heat up to the displayed temperature.



Selecting a temperature

The temperature is electronically controlled.

The temperature can be selected within the range of 30°C to 250°C and can be adjusted at any time. To set the temperature, press the temperature **▲** and temperature **▼** symbols to reach the desired setting.

Touch OK, or if no further changes are made within 8 seconds the oven begins to heat up to the set temperature. The current oven temperature will appear above set temperature. This will change as the oven heats up and the background colour will change from grey to red.

When the temperature is reached, 'Set temperature reached' will appear and only the target temperature will be displayed.

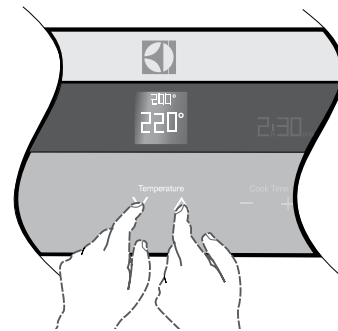

USING THE APPLIANCE

Turning the oven off

Single cavity models:

Touch the **⏻** ON/OFF symbol to switch off the oven.

Double cavity models:

1. Touch the upper/lower oven selector symbol to toggle to the desired oven.
2. Touch the **⏻** ON/OFF symbol to switch off the desired oven. The control panel will come off to confirm that the oven is now switched off.
3. If the other oven is still active, after 1 second, the control panel will automatically revert to show the setting of that oven.
4. To turn off both ovens at once, touch and hold the **⏻** ON/OFF symbol for 1 second. All elements, cavity light and the control panel will then switch off at the same time.

i IMPORTANT!

Pre-heating

Pre-heating the oven is recommended in several cooking and grilling functions. Pre-heating the oven allows it to reach the required temperature quickly and efficiently as well as cook food at the correct temperature for the entire cook time.

These models are equipped with a built-in rapid heat up mode that activates each time you start an oven function. During the rapid heat-up mode the heat comes from the element surrounding the fan as well as the smaller element above the food. This combination will heat up the oven 30% quicker than it would on standard 'Bake' function. The oven will automatically revert to the set cooking function once the preset temperature is reached.

Cooling / Vent fan

The appliance is fitted with a cooling fan. This prevents the kitchen cabinet from overheating and reduces the condensation inside the oven. It will operate whenever the oven is in use and blow warm air across the top of the oven door.

Note: If the oven is still hot from cooking, the cooling fan will keep running to cool the oven down and will switch off by itself once cool.

Condensation

Excess condensation may fog the oven door. This may happen when cooking large quantities of food from a cold start. Minimise condensation by:

- Keeping the amount of water used whilst cooking to a minimum.
- Making sure the oven door is firmly closed.
- Baking custard in a baking dish that is slightly smaller than the water container.
- Cooking casseroles with the lid on.

Note: If using water in cooking, this will turn to steam and may condense outside your appliance. This is not a problem or fault with your oven.

Cooking with the timer

The oven is equipped with a programmable controller that can be used to turn the oven on and off automatically. The 'cook time' controls are used to automatically turn the oven off after a set amount of time. The 'Delay End' controls are used to set the time of day you want the cooking cycle to finish.

Setting the cook time

1. Select the desired oven function and cooking temperature.
2. Touch the 'cook time' **+** symbol as often as necessary (or hold), until the desired cook time has been set.
3. Touch 'OK' or after 8 seconds from the last time adjustment the oven will start cooking and the 'cook time' display will countdown to zero.
4. The oven will turn off and beep when the 'cook time' display reaches zero.

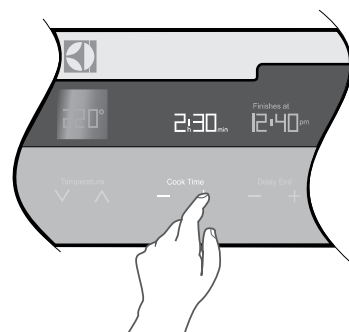

i IMPORTANT!

- When you use the 'cook time' function, the 'Finishes at' display activates and tells you what time of day the oven will turn off (based on the set cook time)
- The cook time can be changed in the first 30 seconds by using the 'cook time' **-** or **+** symbols.
- When the cook time has elapsed, an audible signal will sound for 2 minutes, the oven will switch off and COOKING FINISHED will be displayed.
- To stop the audible signal, press any of the symbols on the control panel.
- If you wish to cook a bit longer, press the 'cook time' **+** symbol for each additional minute you require. The oven automatically reverts to the function and temperature previously programmed. This feature is available for 5 minutes after cooking has finished. After that, the oven automatically switches off.

USING THE APPLIANCE

Setting the delay end time

The delay end function can be used to switch the oven on and off at a specific time during the day.

1. Check the clock displays the correct time of day.
2. Select the desired oven function and cooking temperature.
3. Set the required cook time.
4. Touch the 'delay end' symbol **+** to move the end time.
5. Touch 'OK' or after 8 seconds from the last time adjustment the SET icon will light and the oven is now programmed. The oven will start its cooking cycle to finish at the set 'end time'.
6. When the oven has finished cooking, cook time can be extended or the beeper turned off just as in 'cook time' mode.

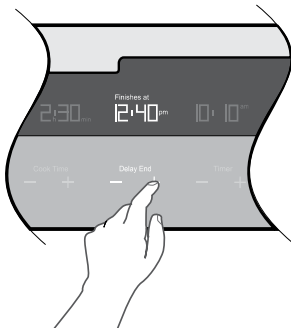

7. Touch the 'delay end' **+** symbol to move the end time forward.
8. Touch 'OK' or after 8 seconds from the last time adjustment the SET icon will light and the oven is now programmed.

The oven will commence its cooking cycle to finish at the set 'end time'

i IMPORTANT!

- 30 seconds after a cooking function has started, it is no longer possible to delay the end time.
- In order to delay a cooking function that has already started, the oven needs to be switched off then switched on again and re-programmed.
- Even though the heating element turns off the oven will still retain substantial heat. This will continue to cook the food until it is removed or the oven cools down. If you do not plan on being present when the oven turns off, you should take this extra heating time into account.

Timers

The appliance has two timers which can be used one at a time. The count up timer can be used to measure a period of time. The count down timer beeps at the end of a preset time.

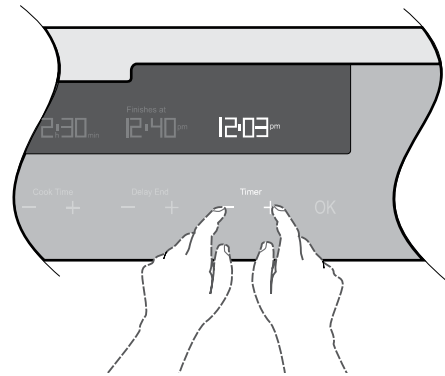

Setting the count up timer

The timer can be used independently of the oven for measuring a count up period. There is no alert provided with this timer.

1. Touch either 'timer' **+** or **-**
2. 00min will be displayed along with a bell and the up arrow will flash.
3. To begin the count up timer press OK.
4. To reset the count up timer, press 'timer' **-** once to show 00min. Press OK to restart.
5. To cancel the count up timer press 'timer' **-** twice.

Setting the count down timer

The timer can be used independently of the oven for setting a count down period. When the period of time has elapsed, an audible signal sounds.

1. Touch either 'timer' **+** or **-**.
2. 00min will be displayed along with a bell and the up arrow will flash.
3. Touch the 'timer' **+** to set the countdown period.
4. The timer bell icon  will flash.
5. To begin the count down timer press OK or wait 8 seconds. When the timer starts, the bell will stop flashing and the timer will begin to count down.
6. When the set time has elapsed, an audible signal will sound for 2 minutes. The time indication '00min' and the timer bell will flash on the display.
7. To stop the signal, touch either of the 'timer' **+** or **-** symbols.
8. To cancel the count down timer touch 'timer' **-** twice.

USING THE APPLIANCE

Adjusting the clock

1. Switch on the oven by touching 'ON/OFF' symbol.
2. Select 'SETTINGS' from the function list and touch OK
3. Select 'SET CLOCK' from the list and touch OK
4. 'Set Clock' will illuminate under the clock display
5. Use the timer **+** and **-** to set the hour portion of the current time (including AM/PM)
6. Touch 'OK' when the hours are set correctly
7. Use the timer **+** and **-** to set the minutes portion of the current time
8. Touch 'OK' when the minutes are set correctly. TIME SAVED will be displayed and then the function display will revert to the 'set clock' menu. Turn the oven off or it will do so after 8 seconds.

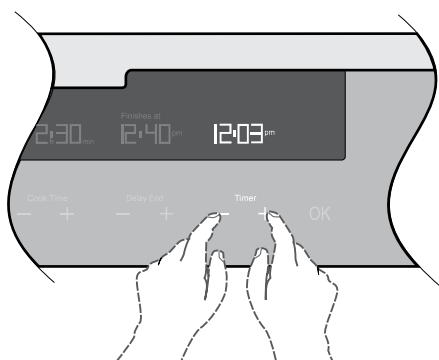

Additional Functionality

Light on/off

Turn the oven light off and on in any cooking mode by simply touching the light  symbol.

DEMO Mode

This mode is intended to be used in retail shops to demonstrate the oven functionality without any power consumption except to the oven lights.

The following instructions show how to enter and exit 'DEMO' mode.

1. Ensure the oven is off by touching the ON/OFF symbol.
2. Touch and hold the ON/OFF symbol until the display turns ON then OFF. Immediately after, touch both the cooktime symbols simultaneously. Hold until a triple beep sounds.

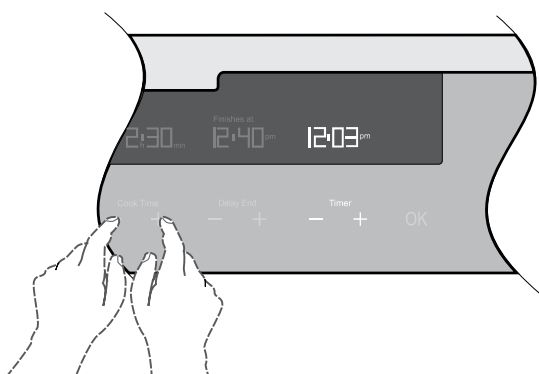

Activating the child-proof lock



When the child lock is engaged, the oven cannot be switched on.



1. Switch on the oven by touching the 'ON/OFF' symbol.
2. Select 'SETTINGS' from the function list and touch 'OK'.
3. Select 'ACTIVATE LOCK' from the list and touch 'OK'.
4. The word 'LOCKED' will momentarily appear and a single beep will sound to confirm the operation. The child lock is now engaged.

De-activating the child lock

1. Touch any symbol on the control panel (including the on/off symbol). 'Locked' will appear on the display.
2. Touch any symbol again. The display will instruct you to touch both 'cook time' symbols for 2 seconds.
3. Hold until a beep sounds. The child lock is now released and the oven is ready to use.

Other settings.

The 'Settings' function gives the opportunity to change oven functionality. Scroll through the list by using function up  or function down .

1. Switch on the oven by touching the 'ON/OFF' symbol.
2. Select 'SETTINGS' from the function list and touch OK
3. Select 'SET CLOCK' to change the time of day.
4. Select 'TIME INDICATION' to have the time permanently displayed or not.
5. Select 'BUZZER VOLUME' to adjust the 'beep on touch' and alarm loudness.
6. Select 'KEY TONE' to turn the 'beep on touch' on or off.
7. Select 'SCREEN BRIGHTNESS' to adjust the brightness of the display.
8. Select 'SCREEN CONTRAST' to adjust the contrast of the display.
9. Select 'TEMPERATURE UNITS' to change between Celsius and Fahrenheit units.
10. Select 'ACTIVATE LOCK' to turn child lock on.
11. Touch 'OK' to go into each selection to change its settings by using function up  or function down .

Safety Cut-out feature

The oven automatically switches itself off if the temperature is not adjusted or the appliance is left operating after a period of time. The oven switches itself off after:

- 12.5 hours when the temperature is set between 30°C and 120°C.
- 8.5 hours when the temperature is set between 120°C and 200°C.
- 5.5 hours when the temperature is set between 200°C and 250°C.

GETTING TO KNOW THE OVEN

Get to know your new oven with this 'Simple Test Cake'

Although we strive for a perfect performing oven, it's possible that there will be some variation in colour when baking. Therefore, we suggest this simple, easy and delicious to make Simple Test Cake, it can help you understand your new oven. All ovens do sometimes have hot or cold spots, therefore it is important to judge with your eye as you may require to rotate during baking.

'Simple Test Cake'

125g butter, softened to room temperature

1 cup caster sugar

1 teaspoon pure vanilla essence

4 large eggs

2 cups self-raising flour

pinch of salt

4 tablespoons (80mL) full-cream milk

Method:

1. Butter base and sides of two, 20cm straight-sided round or square cake pans. Then line the base with grease proof or baking paper.
2. Preheat oven to moderate '180°C' (170°C fan forced) and ensure oven shelf is in the centre position of oven.
3. Cream softened butter and sugar until light in colour.
4. Add vanilla essence.
5. Then eggs one at a time, beating well after each addition.
6. Sift flour and salt into the mixture and beat until well combined.
7. Add milk and beat or stir to combine.
8. Spoon mixture equally between prepared cake pans.
9. Bake in preheated oven, middle shelf for about 25 to 35 minutes or until when tested with a fine cake skewer it comes out clean or the edges of the cakes have come away slightly from the sides of the cake pans.
10. Remove from oven to wire cake rack and rest for 5 minutes before removing from cake pans.

Cool completely.

To Serve: sandwich together with your favourite jam or conserve, and dust top with pure icing sugar.

NOTE: if desired substitute butter for either margarine or olive oil spread. Recipe is based on the Australian standard metric 250mL cup and 20mL tablespoon sets.

EVEP613SA, EVEC615SA, EVEC616BA, EVEC618BA COMPONENTS

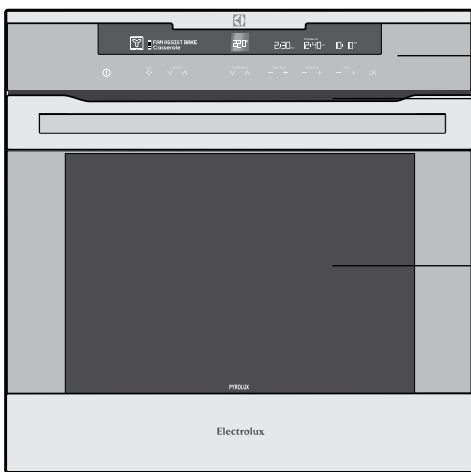
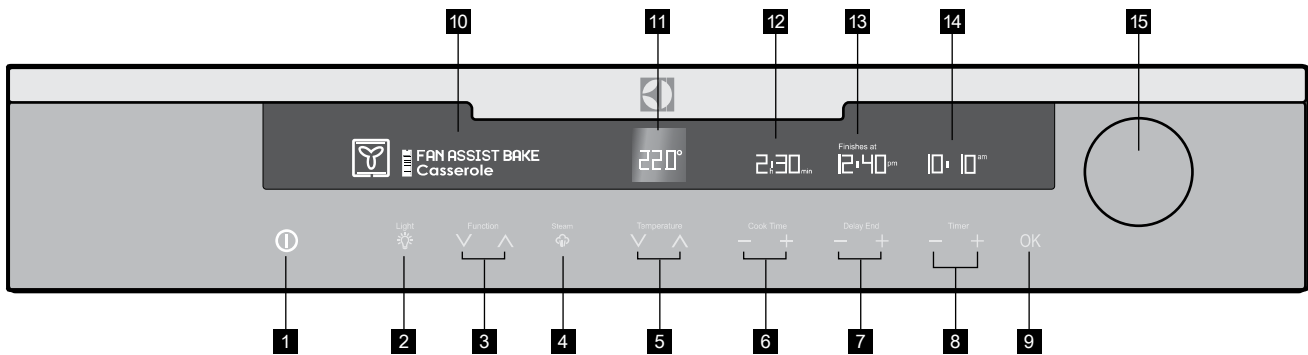

EVEC613SA single cavity stainless steel model

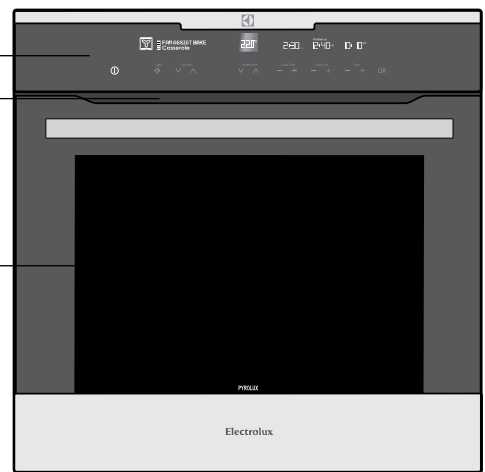

EVEC616BA single cavity black model

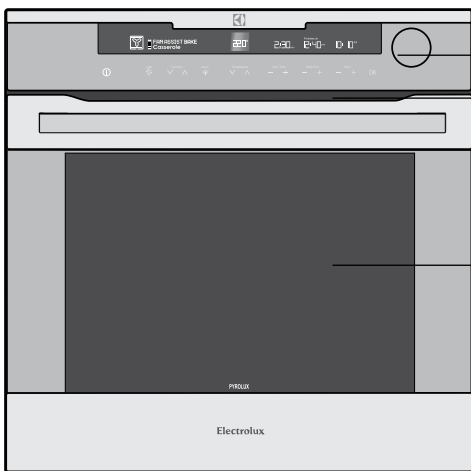

EVEC615SA single cavity stainless steel model
(with steam cooking)

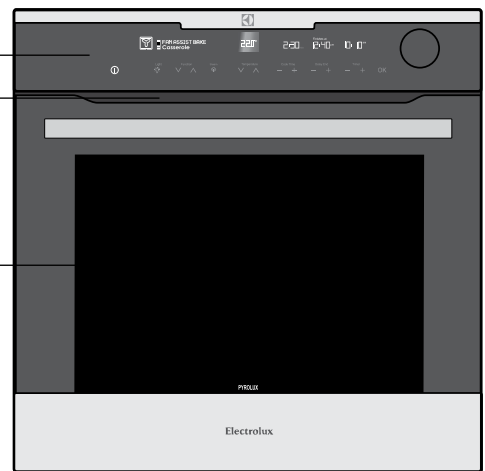

EVEC618BA single cavity black model
(with steam cooking)

- | | | |
|--|---|---|
| <ul style="list-style-type: none"> 1 ON/OFF 2 Light on/off 3 Cooking function selector 4 Steam Cooking option
(EVEC615SA and EVEC618BA only) 5 Temperature control 6 Cook Time control | <ul style="list-style-type: none"> 7 Delay end control 8 Set clock and timer control 9 Instant confirm 10 Cooking function display 11 Temperature display 12 Cook time display 13 Delay end display | <ul style="list-style-type: none"> 14 Clock/timer display 15 Water Drawer
(EVEC615SA and EVEC618BA only) 16 Control panel 17 Warm air exhaust 18 Quad glazed door |
|--|---|---|

BEFORE USING THE APPLIANCE

Preparing the appliance

1. Please remove all stickers, leaflets and boxes from the door and from the floor of the oven before operation.
2. Please wipe out the oven interior prior to operation with warm soapy water and polish dry with a soft clean cloth. Do not close the oven door until the oven is completely dry.
3. Do not line the oven with foil. It will damage the enamel.
4. For the EVEP615SA or EVEP618BA, check the water drawer interior for dust or contaminates. Wipe clean with a damp cloth if necessary.

Setting the time

The time of day must be set before the appliance can operate.

After the appliance has been electrically connected the display will cycle through the welcome screen, then 'Set Clock' will illuminate under the clock display and the Hour digits will flash.

1. Use the timer **+** and **-** to set the hour portion of the current time (including AM/PM)
2. Press OK when the hours are set correctly. The Minute digits will flash
3. Use the timer **+** and **-** to set the minutes portion of the current time
4. Press OK when the minutes are set correctly.
You can turn off the oven or it will do so automatically after 8 seconds.

Once the time has been entered, the clock advances minute by minute.

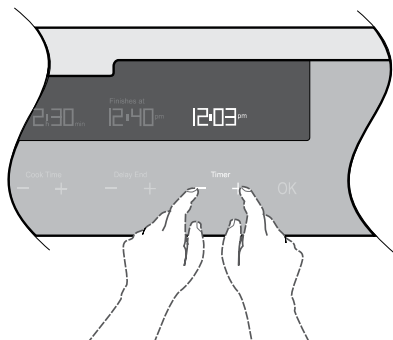

Note: The clock has a 12 hour display and will remember the time for 3 days without power.

i IMPORTANT!

New appliances can have a smell during first use. It is recommended to 'run in' the oven before you cook for the first time. Operate the oven, empty, at a temperature of 180°C for approximately 2 hours. Please ensure the room is well ventilated during this process.

BEFORE USING THE APPLIANCE

Installing your oven accessories

• Side racks

1. Insert the twin pegged side into the rear access holes provided, ensuring pegs are fully inserted.
2. Then locate the front peg into the front access hole and push in firmly.

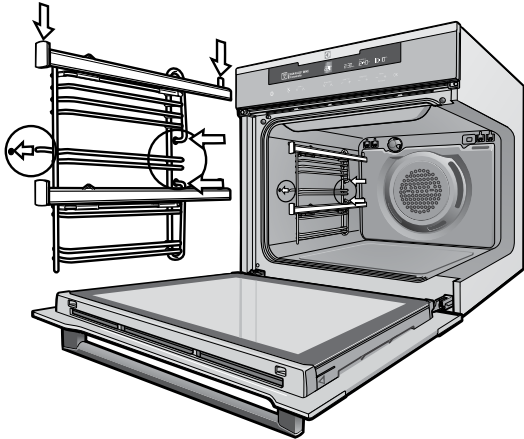

• Shelves and trays

The shelves are designed so that they have maximum extension but cannot be accidentally pulled right out. The trays are designed the same way and slot straight into the side racks.

To fit a shelf or tray to side racks:

1. Locate the rear edge of the shelf/tray in between the guide rails of the side rack – see diagram. Ensure the same rail positions on both sides of the oven are being engaged.
2. With the front edge raised, begin to slide the shelf into the oven.
3. Once the detents have passed the front edge of the side rack, the shelf can be pushed completely in.
4. When fully inserted the shelf/tray should not interfere with the closed oven door.

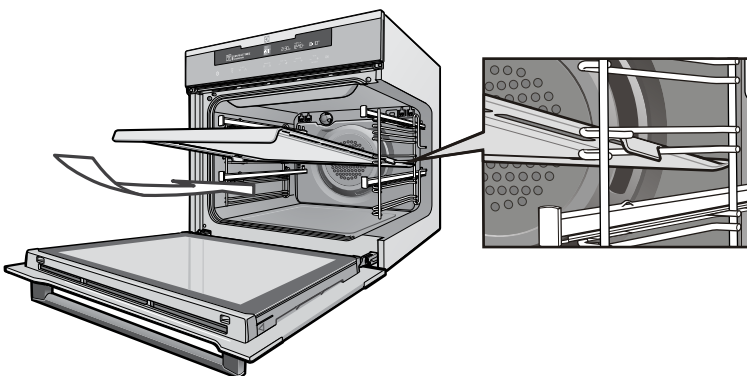





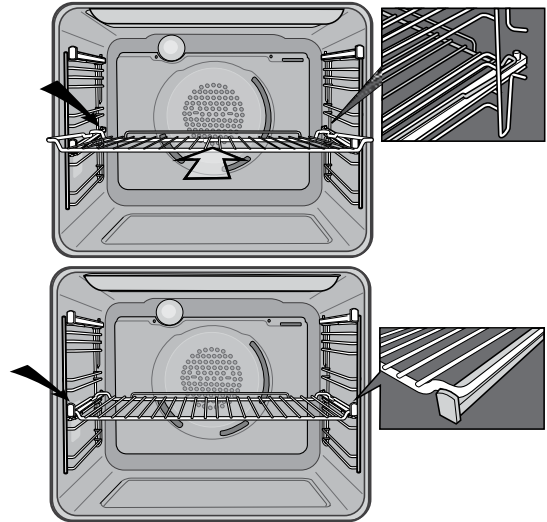









To fit a shelf or tray to telescopic slides:







1. With the slides fully pushed in, push the shelf or tray along the top of the slide until it hits the back post.
2. Drop the front of the shelf or tray onto the slide ensuring it sits behind the front post of the slide.
3. When fully inserted the shelf/tray should not interfere with the closed oven door.



COOKING FUNCTIONS

Symbol	Function description
<p>Fan cooking</p> 	<p>Heat comes from the element surrounding the fan. This fan circulates the hot air around the oven cavity so that you can put your food in different places in the oven and still cook them at the same time. You can use the 'Fan Cooking' function for multi-shelf cooking, reheating cooked foods, pastries and complete oven meals. It will cook at a lower temperature and be faster than baking. Please note that some variation in browning is normal.</p> <p> <i>Note: Models EVEP615SA and EVEP618BA give you the option to introduce steam into this cooking cycle.</i></p>
<p>Steam cooking</p> 	<p>Models EVEP615SA and EVEP618SA only</p> <p>Steam comes from the outlet pipe and heat comes from the element surrounding the fan. This fan circulates the hot air and steam around the oven cavity so that you can put your food in different places in the oven. This combination of steam and hot air together cooks food with a tender interior and crisp exterior. Browning of meat or fish will be perfect with the best cooking result at the core. The shape will be always be preserved and evenly firm. Vegetables will benefit with a high retention of nutrients.</p> <p>Steam will only start if the water tank has been filled and the oven temperature is over 130°C.</p>
<p>Traditional bake</p> 	<p>Heat comes from two elements, one above and one below the food. The bottom element is a clean heat element and is below the floor of the oven. Both elements are controlled by the thermostat and will turn on and off to maintain set temperature. You can use the 'Traditional Bake' function for single shelf cooking, single trays of biscuits, scones, muffins, cakes, slices, casseroles, baked puddings, roasts and delicate egg dishes. This is a general function that can be used for most cooking.</p>
<p>Fan assist bake</p> 	<p>Heat comes from two elements, one above and one below the food. The fan circulates the hot air around the oven cavity so that you can put the food in different places in the oven and still cook them at the same time. You should only use a maximum of two shelves with 'Fan Assist Bake'.</p> <p>Do not use the bottom shelf. If the two shelves are used, food on the shelf in the higher position will cook first and should then be removed to allow the food on the lower shelf to finish cooking.</p> <p> <i>Note: Models EVEP615SA and EVEP618BA give you the option to introduce steam into this cooking cycle.</i></p>
<p>Roast</p> 	<p>This function starts at a higher temperature to seal the meat. The oven will then automatically reduce to the selected temperature to cook the meat for as long as desired. For example, if you use the default 200°C the 'Roast' cycle will start at 240°C and then lower to 200°C.</p> <p> <i>Note: Models EVEP615SA and EVEP618BA give you the option to introduce steam into this cooking cycle.</i></p>
<p>Pastry</p> 	<p>The 'Pastry' function is specially designed for food that require extra browning such as the bases of pastries and pies. Heat comes from the element below the food. If you choose the default setting, the oven will heat up to 230°C in order to brown the food.</p> <p>You should then lower the temperature as required. Cook in the lower half of the oven when you are using only one shelf.</p>
<p>Pizza</p> 	<p>'Pizza' is a combination of 'Pastry' and 'Fan Assist Bake' and offers you the combined benefits of both functions. Heat switches between the element surrounding the fan and the clean heat element below the oven floor. The 'Pizza' function is ideal for foods that require cooking and browning on the base. It is for foods such as pizzas, quiches, meat pies and fruit pies. Simply place the food in the middle of the oven and set the desired temperature.</p> <p> <i>Note: Models EVEP615SA and EVEP618BA give you the option to introduce steam into this cooking cycle.</i></p>
<p>Bread baking</p> 	<p>Models EVEP615SA and EVEP618SA only</p> <p>Steam comes from the outlet pipe and heat comes from the element surrounding the fan. This fan circulates the hot air and steam around the oven cavity so that you can put your food in different places in the oven. The bread baking function creates a great loaf in terms of shape, colour of the top, uniform browning and texture. This function is suggested for baking bread or in general bakery products.</p> <p>Steam will only start if the water tank has been filled and the oven temperature is over 130°C.</p>
<p>Cook from frozen</p> 	<p>The 'Cook from Frozen' function is ideal for cooking frozen precooked foods such as savoury pastries, pizzas, mini meals (TV dinners), meat pies and fruit pies. Heat comes from the element surrounding the fan as well as a smaller element above the food. Simply place the food in the oven straight from the freezer and heat. Cook in the upper half of the oven for best results.</p>
<p>Full grill</p> 	<p>'Full Grill' direct radiant heat from two powerful upper elements onto the food. You can use 'Full Grill' function for tender cuts of meat, steak, chops, sausages, fish, cheese toasties and other quick cooking foods.</p> <p>Grill with the oven door closed.</p> <p>'Full Grill' allows you to take full advantage of the large grill dish area and will cook faster than the 'Half Grill' function. For best results it is recommended to preheat your grill for three minutes. This will help seal in the natural juices of steak, chops etc for a better flavour.</p> <p>You can slide your grill dish into either of the two spaces within the upper pairs of support rails. Full Grill has 2 temperature settings, 'LO' and 'HI'.</p>

COOKING FUNCTIONS

Symbol	Function description
<p>Half grill</p> 	<p>The 'Half Grill' directs radiant heat from only one of the powerful upper elements onto the food. The 'Half Grill' function is used instead of 'Full Grill' when only half the amount of heat is needed. Half Grill has 2 temperature settings, 'LO' and 'HI'.</p> <p>Grill with the oven door closed.</p>
<p>Fan grill</p> 	<p>'Fan Grill' offers you the benefits of both traditional bake and traditional grill functions. The grill element turns on and off to maintain set temperature while the fan circulates the heated oven air.</p> <p>Grill with the oven door closed.</p> <p>You can use 'Fan Grill' for large cuts of meat, which gives you a result similar to 'rotisserie' cooked meat. Put your food on a shelf in the second lowest shelf position. Put the grill dish on the lowest shelf position to catch any spills. When using 'Fan Grill' it is not necessary to turn the food over during the cooking cycle. Set temperature to 180°C.</p>
<p>Steam reheat</p>  	<p>Models EVEP615SA and EVEP618SA only</p> <p>Steam comes from the outlet pipe and heat switches between the element surrounding the fan and the clean heat element below the oven floor. It's not possible to set the temperature for this function. It is fixed at 130°C.</p> <p>To reheat already cooked food (rise, pasta, pizza, vegetables) directly on a plate without drying it out or leaving it soggy.</p> <p>Steam will only start if the water tank has been filled and the oven temperature is over 130°C.</p>
<p>Keep warm</p> 	<p>The 'Keep Warm' function is a low temperature oven function designed to keep your food at a perfect eating temperature without cooking it further. Heat comes from the smaller elements above the food and is circulated by the fan. Use 'Keep Warm' to keep your food warm while you prepare the rest of the meal or afterwards while you wait for the late arrival.</p> <p><i>Note: After cooking, the oven retains enough heat to continue to cook food even if the elements are turned off. The 'Keep warm' function recognises this by giving you a warning message. If this happens the function will not start.</i></p>
<p>Defrost</p> 	<p>The 'Defrost' function uses low temperature air that is circulated by the fan. You can defrost (thaw) your food before you cook it. You can also use 'defrost' to raise your yeast dough and to dry fruit, vegetables and herbs. The 'Defrost' function does not have a suggested temperature but uses the ambient heat in the oven cavity.</p>
<p>Pyro clean</p> 	<p>The 'pyrolytic cleaning' function cleans by burning off the spatters and accumulated dirt and grease from the oven liner, at high temperature. This process produces ash which can be wiped out of the oven cavity.</p>

OPERATING SEQUENCE

Turning the oven on

- Switch on the oven by touching the **ⓘ** ON/OFF symbol. The LCD control panel will come on and inform you that you need to select a cooking function.
- If you do not select a function within 20 seconds the oven will turn off.

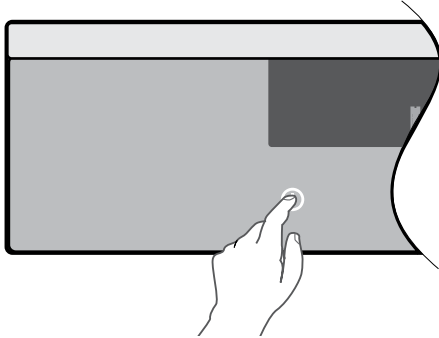

Select a cooking function

The oven will have a selection of functions. Press the function **▲** or function **▼** symbols as many times as necessary until the desired function appears.

Cooking suggestions will appear under the function name and suggested cooking temperatures will appear above the temperature selector.

If no other symbol is touched within 8 seconds the oven will switch on and begin to heat up to the displayed temperature.



Selecting a temperature

The temperature is electronically controlled.

The temperature can be selected within the range of 30°C to 250°C and can be adjusted at any time. To set the temperature, press the temperature **▲** and temperature **▼** symbols to reach the desired setting.

Touch OK, or if no further changes are made within 8 seconds the oven begins to heat up to the set temperature. The current oven temperature will appear above set temperature. This will change as the oven heats up and the background colour will change from grey to red.

When the temperature is reached, 'Set temperature reached' will appear and only the target temperature will be displayed.

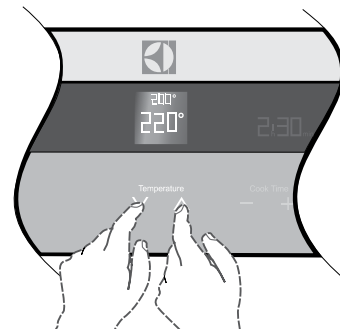

Turning the oven off

Touch the **ⓘ** ON/OFF symbol to switch off the oven.

As the appliance cools down "cooling" will be displayed until the oven reaches approximately 100°C.

USING THE APPLIANCE

i IMPORTANT!

Pre-heating

Pre-heating the oven is recommended in several cooking and grilling functions. Pre-heating the oven allows it to reach the required temperature quickly and efficiently as well as cook food at the correct temperature for the entire cook time.

These models are equipped with a built-in rapid heat up mode that activates each time you start an oven function. During the rapid heat-up mode the heat comes from the element surrounding the fan as well as the smaller element above the food. This combination will heat up the oven 30% quicker than it would on standard 'Bake' function. The oven will automatically revert to the set cooking function once the preset temperature is reached.

Cooling / Vent fan

The appliance is fitted with a cooling fan. This prevents the kitchen cabinet from overheating and reduces the condensation inside the oven. It will operate whenever the oven is in use and blow warm air across the top of the oven door.

Note: If the oven is still hot from cooking, the cooling fan will keep running to cool the oven down and will switch off by itself once cool.

Condensation

Excess condensation may fog the oven door. This may happen when cooking large quantities of food from a cold start. Minimise condensation by:

- Keeping the amount of water used whilst cooking to a minimum.
- Making sure the oven door is firmly closed.
- Baking custard in a baking dish that is slightly smaller than the water container.
- Cooking casseroles with the lid on.

Note: If using water in cooking, this will turn to steam and may condense outside your appliance. This is not a problem or fault with your oven.

Cooking with the timer

The oven is equipped with a programmable controller that can be used to turn the oven on and off automatically. The 'cook time' controls are used to automatically turn the oven off after a set amount of time. The 'Delay End' controls are used to set the time of day you want the cooking cycle to finish.

Setting the cook time

1. Select the desired oven function and cooking temperature.
2. Touch the 'cook time' **+** symbol as often as necessary (or hold), until the desired cook time has been set.
3. Touch 'OK' or after 8 seconds from the last time adjustment the oven will start cooking and the 'cook time' display will countdown to zero.
4. The oven will turn off and beep when the 'cook time' display reaches zero.

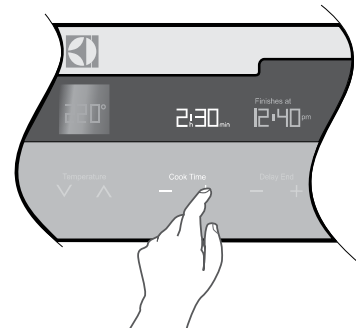

i IMPORTANT!

- When you use the 'cook time' function, the 'Finishes at' display activates and tells you what time of day the oven will turn off (based on the set cook time)
- During cooking, you can adjust the cook time with the 'cook time' **-** or **+** symbols for better cooking performance.
- When the cook time has elapsed, an audible signal will sound for 2 minutes, the oven will switch off and COOKING FINISHED will be displayed.
- To stop the audible signal, press any of the symbols on the control panel.
- If you wish to cook a bit longer, press the 'cook time' **+** symbol for each additional minute you require. The oven automatically reverts to the function and temperature previously programmed. This feature is available for 5 minutes after cooking has finished. After that, the oven automatically switches off.

USING THE APPLIANCE

Setting the delay end time

The delay end function can be used to switch the oven on and off at a specific time during the day.

1. Check the clock displays the correct time of day.
2. Select the desired oven function and cooking temperature.
3. Set the required cook time.
4. Touch the 'delay end' symbol **+** to move the end time.
5. Touch 'OK' or after 8 seconds from the last time adjustment the SET icon will light and the oven is now programmed. The oven will start its cooking cycle to finish at the set 'end time'.
6. When the oven has finished cooking, cook time can be extended or the beeper turned off just as in 'cook time' mode.

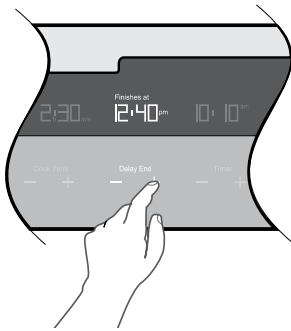

7. Touch the 'delay end' **+** symbol to move the end time forward.
8. Touch 'OK' or after 8 seconds from the last time adjustment the SET icon will light and the oven is now programmed.

The oven will commence its cooking cycle to finish at the set 'end time'

i IMPORTANT!

- 30 seconds after a cooking function has started, it is no longer possible to delay the end time.
- In order to delay a cooking function that has already started, the oven needs to be switched off then switched on again and re-programmed.
- Even though the heating element turns off the oven will still retain substantial heat. This will continue to cook the food until it is removed or the oven cools down. If you do not plan on being present when the oven turns off, you should take this extra heating time into account.

Timers

The appliance has two timers which can be used one at a time. The count up timer can be used to measure a period of time. The count down timer beeps at the end of a preset time.

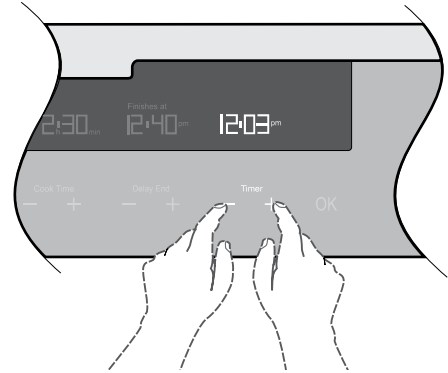

Setting the count up timer

The timer can be used independently of the oven for measuring a count up period. There is no alert provided with this timer.

1. Touch either 'timer' **+** or **-**
2. 00min will be displayed along with a bell and the up arrow will flash.
3. To begin the count up timer press OK.
4. To reset the count up timer, press 'timer' **-** once to show 00min. Press OK to restart.
5. To cancel the count up timer press 'timer' **-** twice.

Setting the count down timer

The timer can be used independently of the oven for setting a count down period. When the period of time has elapsed, an audible signal sounds.

1. Touch either 'timer' **+** or **-**.
2. 00min will be displayed along with a bell and the up arrow will flash.
3. Touch the 'timer' **+** to set the countdown period.
4. The timer bell icon  will flash.
5. To begin the count down timer press OK or wait 8 seconds. When the timer starts, the bell will stop flashing and the timer will begin to count down.
6. When the set time has elapsed, an audible signal will sound for 2 minutes. The time indication '00min' and the timer bell will flash on the display.
7. To stop the signal, touch either of the 'timer' **+** or **-** symbols.
8. To cancel the count down timer touch 'timer' **-** twice.

USING THE APPLIANCE

Adjusting the clock

1. Switch on the oven by touching 'ON/OFF' symbol.
2. Select 'SETTINGS' from the function list and touch OK
3. Select 'SET CLOCK' from the list and touch OK
4. 'Set Clock' will illuminate under the clock display
5. Use the timer **+** and **-** to set the hour portion of the current time (including AM/PM)
6. Touch 'OK' when the hours are set correctly
7. Use the timer **+** and **-** to set the minutes portion of the current time
8. Touch 'OK' when the minutes are set correctly. TIME SAVED will be displayed and then the function display will revert to the 'set clock' menu. Turn the oven off or it will do so after 8 seconds.

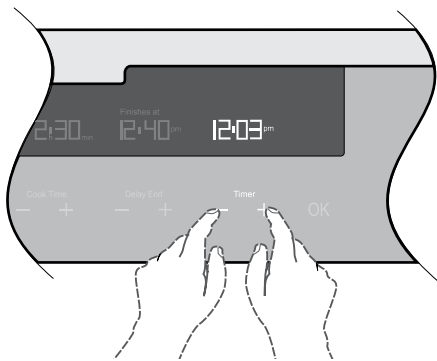

Steam assisted cooking

EVEP615SA and EVEP618BA models only

Cooking with steam is a great addition to straight 'hot air' cooking. Steam brings out all the natural flavours and goodness in the food, cooks evenly from surface to centre and retains more nutrients and vitamins. Steam assisted cooking consistently produces juicy, succulent interiors with crisp, golden exteriors.

These models have three dedicated steam functions that have been individually tuned to produce the best result with a combination of steam and heat application. They are-

Steam cooking.

Perfect for all kinds meat, poultry and fish dishes. The hot air ensures the outside is sealed whilst the steam keeps the inside tender.

Steam reheat.

Rejuvenates food like it was just cooked. Great for reheating dishes like rice, pasta and pizza that can suffer from dryness in normal ovens or sogginess in microwave ovens.

Bread baking.

Specially programmed for buns and loaves of bread. This function gives perfect, fluffy insides with crisp golden crusts. See 'getting to know your oven' on page 46 For directions of use.

Steam on demand

During the cooking process some functions will allow the user to switch between standard cooking and steam assisted cooking. This is useful if the food is drying out or the meal requires a higher retention of moisture. Steam can be introduced by pressing the  symbol. This option is available for the following functions:

- Fan cooking
- Fan assist bake
- Roast
- Pizza
- Cook from frozen

It will always be possible to switch back to standard cooking by again pressing the  symbol.

Note: the ability to switch between steam and standard cooking is only available on the above functions. Pressing the  symbol on any other function will have no effect. Steam can only be generated if there is water in the tank and the oven temperature is over 130°C.

Steam product description

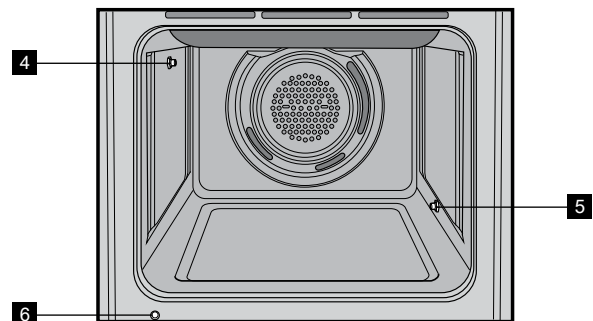
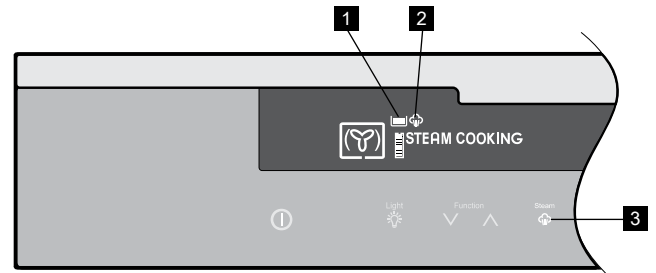

1 Water tank Level Indicator

 – Tank empty.

 – Water present.

 – Tank full. Overfill alarm will sound.

Press 'OK' to continue.

2 Steam function in progress.

3 Steam On Demand. Available for certain functions only.

4 Steam outlet. This is where steam is injected into the oven.

5 Water overflow pipe. If the water tank is over filled, water will be dispensed into the oven from here. This is not a fault with the appliance. It prevents water spilling out of the water drawer which could create a hazard. If this occurs mop up the overflow with a clean cloth and continue with the cooking function.

6 Water outlet valve. To be used with the draining pipe (supplied). Any water left in the tank is to be drained after the appliance has cooled down.

USING THE APPLIANCE

Steam operating sequence

1. Open the water drawer in the control panel by pressing it.
2. Pour approximately 850ml of water into the drawer. The water level indicator on the display will show one to two bars. Close the water drawer.

! WARNING!

Take care when filling the water drawer. Spillage could create a slipping hazard. Immediately clean up any spills on the product, cabinet or floor. If the overflow alarm sounds immediately stop pouring water into the water drawer. If the tank is overfilled the excess will flow into the oven. This prevents leakage onto cabinets and is not a fault. Sponge up overflows if they occur.

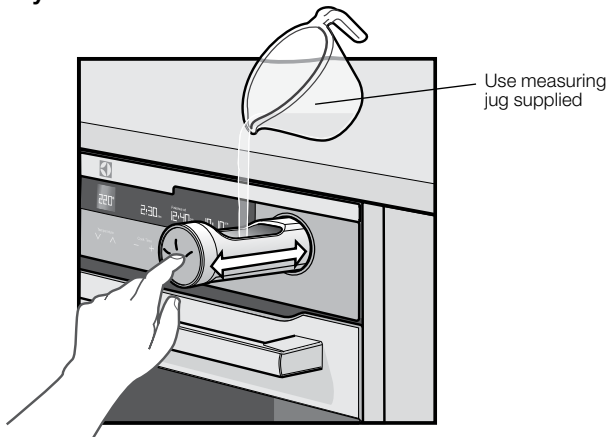

! CAUTION!

Do not use any liquid other than normal tap water. Do not use demineralised or distilled water. Doing so could affect the normal operation of the steam generator. Do not put solid matter into the water drawer.

3. Turn on the oven and select the steam cooking function and temperature as per normal operation. Set timer functions if desired.
4. Once the oven has reached the desired temperature put the food in and cook as planned. A full water tank will last approximately 30mins. It may have to be refilled during a long cooking cycle, for example, a roast.
5. Once cooking is complete remove the food and turn off the oven. Leave the oven door ajar to aid drying of the oven.
6. Drain water tank once the appliance is cool

! WARNING!

The steam is not visible inside the oven but it is there. Opening the oven door to place, remove or inspect food will release it. Stand back when opening the door to avoid the risk of burns.

Emptying the water tank.

The water tank must be emptied after every steam assisted cooking cycle. This is done by:

1. Open the oven door to reveal the water outlet valve.
2. Insert the valve end of the supplied drain pipe into the water outlet valve. Ensure the other end is in a container that can take up to 1 litre.
3. Remove the drain pipe only when the water stops flowing.
4. Soak up any leakages with a sponge or cloth.

! WARNING!

Water in the tank can still be hot. Wait until the appliance is cool before the water tank is drained.

Do not use the drained water to fill the water tank again.

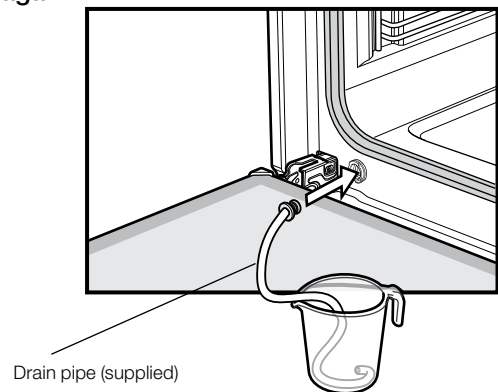

Additional Functionality

Light on/off

Turn the oven light off and on in any cooking mode by simply touching the light  symbol.

DEMO Mode

This mode is intended to be used in retail shops to demonstrate the oven functionality without any power consumption except to the oven lights.

The following instructions show how to enter and exit 'DEMO' mode.

1. Ensure the oven is off by touching the ON/OFF symbol.
2. Touch and hold the ON/OFF symbol until the display turns ON then OFF. Immediately after, touch both the cooktime symbols simultaneously. Hold until a triple beep sounds.

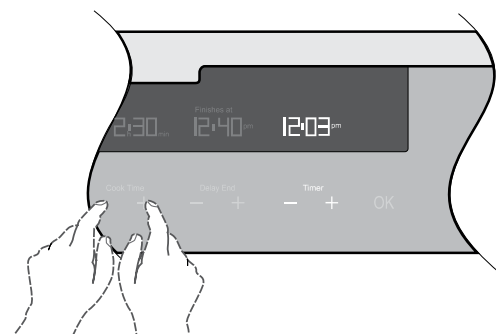

USING THE APPLIANCE

Activating the child-proof lock



When the child lock is engaged, the oven cannot be switched on.



1. Switch on the oven by touching the 'ON/OFF' symbol.
2. Select 'SETTINGS' from the function list and touch 'OK'.
3. Select 'ACTIVATE LOCK' from the list and touch 'OK'.
4. The word 'LOCKED' will momentarily appear and a single beep will sound to confirm the operation. The child lock is now engaged.

De-activating the child lock

1. Touch any symbol on the control panel (including the on/off symbol). 'Locked' will appear on the display.
2. Touch any symbol again. The display will instruct you to touch both 'cook time' symbols for 2 seconds.
3. Hold until a beep sounds. The child lock is now released and the oven is ready to use.

Other settings.

The 'Settings' function gives the opportunity to change oven functionality. Scroll through the list by using function up  or function down .

1. Switch on the oven by touching the 'ON/OFF' symbol.
2. Select 'SETTINGS' from the function list and touch OK
3. Select 'SET CLOCK' to change the time of day.
4. Select 'TIME INDICATION' to have the time permanently displayed or not.
5. Select 'BUZZER VOLUME' to adjust the 'beep on touch' and alarm loudness.
6. Select 'KEY TONE' to turn the 'beep on touch' on or off.
7. Select 'SCREEN BRIGHTNESS' to adjust the brightness of the display.
8. Select 'SCREEN CONTRAST' to adjust the contrast of the display.
9. Select 'TEMPERATURE UNITS' to change between Celsius and Fahrenheit units.
10. Select 'ACTIVATE LOCK' to turn child lock on.
11. Touch 'OK' to go into each selection to change its settings by using function up  and function down .

Safety Cut-out feature

The oven automatically switches itself off if the temperature is not adjusted or the appliance is left operating after a period of time. The oven switches itself off after:

- 12.5 hours when the temperature is set between 30°C and 120°C.
- 8.5 hours when the temperature is set between 120°C and 200°C.
- 5.5 hours when the temperature is set between 200°C and 250°C.

CLEANING THE OVEN

Cleaning steam parts

Models EVEP615SA and EVEP618BA only.

After some time, the water drawer can accumulate deposits. To delay this, empty the tank after each steam cooking and clean the water tank every two to three months using the following process.

WARNING!

Do not put water into the water tank during the cleaning procedure.

To prevent damage, do not use acids, sprays or similar cleaning agents.

IMPORTANT!

During the cleaning procedure, some water can drip from the steam outlet onto the cavity of the oven. Put a dripping pan on the shelf level directly below the steam inlet to prevent water from falling onto the bottom of the oven cavity.

Cleaning procedure

1. Fill in the water tank with 850 ml of water and 50 ml of citric acid (five teaspoons). Deactivate the oven and wait for approximately 60 minutes.
2. Activate the oven and set to 'steam cooking'. Set the temperature 230°C. Deactivate it after 25 minutes and let it cool down for 15 minutes.
3. Activate the oven and set to 'steam cooking'. Set the temperature between 130 and 230°C. Deactivate it after 10 minutes. Let it cool down and empty the water tank of remaining water.
4. Refill the water tank with tap water and then empty via the drain pipe.
5. Clean the drain pipe by hand in warm water with soap.
6. To prevent build up of calcium deposits it is recommended to use this procedure every 2-3 months.

Pyrolytic cleaning of the oven cavity

The oven has the Pyrolytic self-cleaning function, it cleans by burning off the spatters and accumulated dirt and grease from the oven liner, at high temperature. This process produces ash which can then be wiped out of the oven cavity.

WARNING!

During the pyrolytic cleaning process the oven becomes extremely hot.

- Please keep small children at a safe distance.
- Never clean non-stick baking trays and tins in the oven during the pyrolytic cycle. High temperatures damage the non-stick coating and poisonous gas is released.

CAUTION!

- During pyrolytic cleaning the air outlet exhaust above the door must be kept clear of any obstruction (eg bulky tea towels).
- Do not use your oven to clean miscellaneous items (eg cookware).
- If you have a steam oven, do not cause the water tank to overflow during the cleaning cycle. This could damage the enamel

Before carrying out the Pyrolytic function

1. All accessories must be removed from the oven, including shelves, trays and side racks.
2. Clean large deposits, spills or grease from the oven cavity.
3. If you have a steam oven ensure the water tank is empty.
4. Choose your Pyrolytic cleaning cycle from the following:

soiling	duration
light clean	1hr 30mins
medium clean	2hrs
heavy clean	2hr 30mins

Note: Duration includes heat-up time.

• Light clean

This is an energy saving cycle that can be used on a regular basis if the oven is lightly soiled. Possibly after every 2nd or 3rd roast.

• Medium clean

Use this as the regular cycle about once every 2-3 months.

• Heavy clean

When the oven is very dirty it may need a longer cycle to clean it thoroughly. This cycle will clean the dirtiest of ovens.

CLEANING THE OVEN

Select the pyrolytic clean function.

Use cooking function selector to pick the 'pyro clean' function

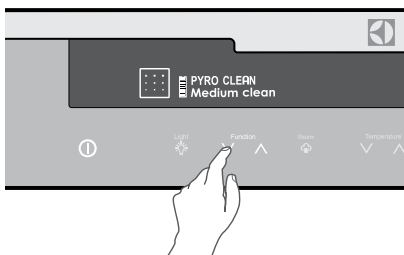

Selecting the required cleaning cycle

Use the 'cook time' control to select Light, Medium or Heavy depending on the soiling of the oven.

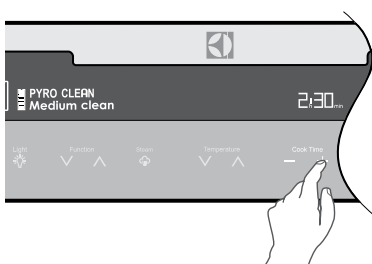

Start Pyrolytic

Unlike other cooking functions, you MUST touch 'OK' for the pyrolytic cycle to start. The display will prompt you to remove all shelves and trays. You must touch 'OK' again to start. The oven light will then go out and the Pyrolytic function will start.

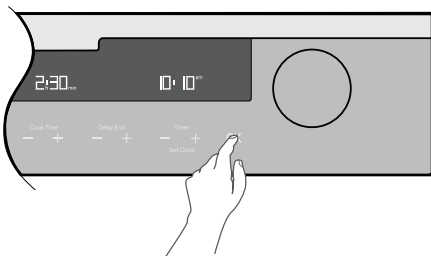

After Pyrolytic cleaning

After cool-down wipe the ash out of the oven with a soft damp cloth and warm water.

To restore the enamel shine to more difficult areas, use a damp cloth with vinegar and detergent.

CAUTION!

Do not turn off the mains power supply to the oven during the pyrolytic cycle. This could damage the appliance

i IMPORTANT!

At the beginning of pyrolytic cleaning the door will automatically lock  will appear on the display.

The door will only unlock when the oven has cooled to a safe temperature. Turning the function off will not unlock the door. This will only happen when safe temperatures are reached.

When the pyrolytic cleaning function is on, it is advisable not to use a cooktop if it is fitted above the oven. This could cause overheating and damage to both appliances.

Note: The cooling fan will operate at an increased speed for Pyrolytic cleaning and will continue to run until the oven has cooled down. This is normal.

It is recommended to clean the oven regularly to keep it in its best condition.

GETTING TO KNOW THE OVEN

Get to know the oven with this 'Simple Test Cake'

Although we strive for a perfect performing oven, it's possible that there will be some variation in colour when baking. Therefore, we suggest this simple, easy and delicious to make Simple Test Cake, it can help you understand your new oven. All ovens do sometimes have hot or cold spots, therefore it is important to judge with your eye as you may require to rotate during baking.

'Simple Test Cake'

125g butter, softened to room temperature
1 cup caster sugar
1 teaspoon pure vanilla essence
4 large eggs
2 cups self-raising flour
pinch of salt
4 tablespoons (80mL) full-cream milk

Method:

1. Butter base and sides of two, 20cm straight-sided round or square cake pans. Then line the base with grease proof or baking paper.
2. Preheat oven to moderate '180°C' (170°C fan forced) and ensure oven shelf is in the centre position of oven.
3. Cream softened butter and sugar until light in colour.
4. Add vanilla essence.
5. Then eggs one at a time, beating well after each addition.
6. Sift flour and salt into the mixture and beat until well combined.
7. Add milk and beat or stir to combine.
8. Spoon mixture equally between prepared cake pans.
9. Bake in preheated oven, middle shelf for about 25 to 35 minutes or until when tested with a fine cake skewer it comes out clean or the edges of the cakes have come away slightly from the sides of the cake pans.
10. Remove from oven to wire cake rack and rest for 5 minutes before removing from cake pans.

Cool completely.

To Serve: sandwich together with your favourite jam or conserve, and dust top with pure icing sugar.

NOTE: if desired substitute butter for either margarine or olive oil spread. Recipe is based on the Australian standard metric 250mL cup and 20mL tablespoon sets.

Using the bread baking function

To aid you in baking bread here is basic recipe to understand and experiment with the bread baking function.

'Test loaf from base ingredients'

500 g wheat flour
10 g salt
10 g butter at room temperature
280 +/- 20 g water at 37 °C +/- 2 °C
3 g sugar
20 g fresh yeast

Method

1. Weigh wheat flour, salt and butter in mixing bowl of the food processor.
2. Dissolve sugar and yeast in the warm water and add to the flour.
3. If using a mixing machine, mix on slow speed for 2 minutes. Then mix on medium for 8 minutes or until dough is smooth.
4. Shape round ball of 750g of the dough, put in a bowl, cover with cling film and let it rise for 45min in the oven at 30°C (or in defrost mode).
5. Shape a longish loaf, cover with a towel and let it rise for 45 min in the oven at 30°C (or in defrost mode).
6. Carve the surface of the bread with a serrated knife, depth of the cuts around 5 mm.
7. Choose 'bread baking' function, ensure water is in the tank and pre-heat the oven to 180°C for 10 mins.
8. Place the dough in shelf level 2 and cook for 40-45 min.
9. Refill the water tank if it becomes empty before the end of the cycle.
10. Remove loaf and allow to cool.
11. Drain any left over water from the tank once the appliance is cool.

COOKING GUIDE

- Select the correct shelf location for food being cooked.
- Make sure dishes will fit into the oven before it is switched on
- Keep edges of non Electrolux baking dishes at least 40mm from the side of the oven. This allows free circulation of heat and ensures even cooking.
- Do not open the oven door more than necessary.
- Do not place foods with a lot of liquid into the oven with other foods. This will cause food to steam and not brown.
- After the oven is turned off it retains the heat for some time. Use this heat to finish custards or to dry bread.
- Do not use a lot of cooking oil when roasting. This will prevent splattering oil on the sides of the oven and the oven door.
- When cooking items that require a high heat (e.g. tarts), place the cooking dish on a scone tray in the desired shelf position.
- For sponges and cakes use aluminium, bright finished or non-stick cookware.

Condensation

Excess condensation may fog the oven door. This may happen when you are cooking large quantities of food from a cold start. Minimise condensation by:

- Keeping the amount of water used whilst cooking to a minimum.
- Making sure the oven door is firmly closed.
- Baking custard in a baking dish that is slightly smaller than the water container.
- Cooking casseroles with the lid on.
- If water is being used in cooking, it will turn to steam and may condense outside your appliance. This is not a problem or fault with the appliance.

Oven shelf location

The oven has 8 positions for shelves (as shown in the example below). To give maximum space above and below the shelves, load them in this way:

- When cooking with 1 shelf, position at 1 or 2.
- When cooking with 2 shelves, position them at 2 and 6.

For more detailed shelf locations. Refer to cooking tables for individual cooking functions.

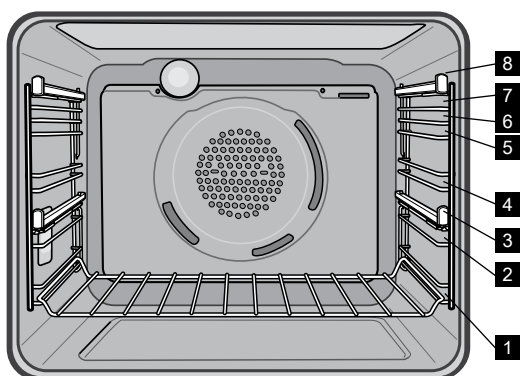

ENVIRONMENT!

To save energy and to help protect the environment, we recommend these hints:

Use the oven efficiently by cooking many trays of food at the same time. For example:

- Cook 2 trays of scones, small cakes or sausage rolls.
- Cook a roast dinner at the same time as you cook chips or vegetables.

Roasting meat (use roasting tray & insert)

- Place the meat in the oven and set the temperature between 180°C and 200°C. (It is recommended to wrap your meats in an oven roasting bag or foil to prevent fats and oils from splattering. This will make it easier to clean the oven.)
- Use the grill/oven dish and anti spatter grill inserts. Place the meat on the inserts.
- Do not pierce the meat.
- When the meat is cooked, take the roast out of the oven, wrap in aluminium foil and leave to stand for about 10 minutes. This will help retain the juices when the meat is carved. The table below shows temperatures and cooking times for different kinds of meat. These may vary depending on the thickness and bone content of the meat.

Roasting poultry and fish

- Place the poultry or fish in an oven set at a moderate temperature of 180°C - 200°C.
- Place a layer of foil over the fish for about three quarters of the cooking time. The table shows the temperatures and the cooking times for different kinds of fish and poultry. These may vary depending on the thickness and bone content of the meat.

COOKING GUIDE

Cooking guide

meat	recommended temperature °C	minutes per kg
beef	200	rare: 35-40
		medium: 45-50
		well done 55-60
lamb	200	medium: 40
		well done 60
veal	180	well done 60
pork	200	well done 60

poultry & fish	recommended temperature °C	minutes per kg
chicken	200	45-50
duck	200	60-70
turkey	180	40-45 (<10kg)
		35-40 (>10kg)
fish	180	20

 **IMPORTANT!**

For best cooking results pre-heat your oven and grill. Pre-heating reaches the required temperature quickly and efficiently as well as cook your food at the correct temperature for the entire cook time. For best baking results preheat oven for 30 minutes.

Temperature estimations

If a recipe calls for Fahrenheit (°F) or no actual temperatures, use the following table to determine the temperature (°C).

oven		temp. °C	temp. °F
low heat	cool	80	175
	very slow	100-110	210-230
	slow	130-140	265-285
moderate heat	moderately slow	150-160	300-320
	moderate	170-180	340-355
	moderately hot	190-200	375-390
high heat	hot	200-210	390-410
	very hot	220-230	430-450
	extremely hot	240-250	465-480

COOKING GUIDE

Traditional baking

food		temperature °c	oven shelf position*	time in minutes
scones	– plain or fruit	220	1	10
biscuits	– rolled	170	2	10-15
	– spooned	190	2	12-15
	– shortbread biscuits	160	1 or 2	30-35
meringues	– hard – individual	110	2	90
	– soft – individual	180	2	15-20
	– pavlova – 4 egg whites	110	1	75
cakes	– patty cakes	190	2	15-20
	– sponge – 4 eggs	180	2	20-30
	– shallow butter cake	180	2	30-40
	– boiled fruit cake	180	1	60-70
pastry – shortcrust	– cornish pasties	200	2	40-45
	– custard tart	200/180	1	10/30-30
pastry – choux	– cream puffs	210	2	25-30
yeast goods	– bread	210	1	25-30
	– pizza	220	2	18

*Counting from the bottom position up

Fan cooking

food		temperature °c	oven shelf position*	time in minutes
scones	– plain or fruit	210	2 and 6	10-15
biscuits	– rolled	150	any	10-15
	– spooned	180	any	10-15
	– shortbread biscuits	150	any	10-15
meringues	– hard – individual	100	any	90
	– soft – individual	165	any	15-20
	– pavlova – 4 egg whites	100	2 and 6	75
cakes	– patty cakes	180	2 and 6	15-20
	– sponge – 4 eggs	170	2 and 6	20-30
	– shallow butter cake	170	any	30-40
	– boiled fruit cake	170	1	60-70
pastry – shortcrust	– cornish pasties	180	any	40-45
	– custard tart	190/170	any	20-30
pastry – choux	– cream puffs	200	any	25-30
yeast goods	– bread	210	1	25-30
	– pizza	220	2	18

COOKING GUIDE

Steam cooking

food		temperature °C	oven shelf position*	time in minutes
cakes and pastries	– apple cakes in a 20cm cake tin	140	2	60-80
	– biscuits on a baking tray	150	3 (2 and 4)	20-40
	– sweet buns on a baking tray	180-200	2	10-20
flan	– vegetable in a dish	170-180	1	20-40
	– lasagne in a dish	170-180	2	40-50
	– potato gratin in a dish	160-170	2	50-60
meat	– roast pork	180-200	2	90-110/kg
	– veal	180	2	35-45/kg
	– roast beef			
	• rare	210	2	35-40/kg
	• medium	200	2	40-45/kg
	• well done	190	2	50-55/kg
	– whole chicken	200	2	50-55/kg
fish and seafood	– snapper 1-1.5kg	140-150	2	15-25
	– barramundi 4 fillets	180	2	10-15
miscellaneous	tray of vegetables 500g	130	2	20-25
	pizza (fresh)	210	2	14-18

*Counting from the bottom position up

Bread baking

food		temperature °c	oven shelf position*	time in minutes
bread	– rolls	200	2	20-25
	– loaves	180	2	35-45
	– foccacia	200-210	2	15-25

GRILLING GUIDE

Grilling hints

As a method of cooking, grilling can be used to:

- Enhance the flavours of vegetables, fish, poultry and meat.
- Seal the surface of the food and retain natural juices.
- Grill with the door closed.

This table shows how to grill different types of meat:

food	grilling method
beef – tenderloin, rump and sirloin.	brush with oil or melted butter, especially if the meat is very lean
lamb – loin chops, shortloin chops, chump chops and forequarter chops.	remove skin or cut at intervals to avoid curling. brush with oil or melted butter
sausages	prick sausages to stop skin from bursting
poultry	divide into serving pieces. brush with oil
fish	brush with oil or melted butter and lemon juice
bacon	remove rind, grill flat and make into rolls

Fan grill

The 'fan grill' function will assist the grilling process by circulating the heat evenly around the food. The recommended temperature setting is 180°C for all fan grilling functions.

- Use the anti spatter insert and grill dish for all fan grilling. Position the dish in the lower half of the oven, for best results.
- Wipe off any oil or fat which splatters while the oven is still warm.
- There is no need to turn meat as both sides are cooked at the same time which means the food is succulent.

WARNING!

Always clean the grill/oven dish after every use. Excessive fat build up may cause a fire.

Guide to better grilling

No definite times can be given for grilling because this depends on your own tastes and the size of the food. These times should only be used as a guide and remember to turn the food over half way through the cooking process.

food	time in minutes
Steak	15-20
Chops	20-30
Fish	8-10
Bacon	4-5

For better grilling results, follow these easy instructions:

- Remove oven/grill dish and grill insert and preheat grill for about 5 minutes.
- Choose only prime cuts of meat or fish. If the cut is less than 5mm thick it will dry out. If the cut is more than 40mm thick, the outside may burn whilst the inside remains raw.
- Do not place aluminium foil under food as this prevents fats and oils from draining away, which could result in a fire.
- Baste the food during grilling with butter, olive oil or marinade. Grilled food is better if marinated before cooking.
- Use tongs to turn food as a fork pierces the surface and will let juices escape.

DEALING WITH COOKING PROBLEMS

problem	possible causes	remedies
Uneven cooking	Incorrect shelf position	• Select shelf suitable for cooking function. See cooking function tables in cooking guide
	Oven tray too large	• Experiment with other trays or dishes
	Trays not centralised	• Centre trays
	Air flow in oven uneven	• Rotate food during cooking
	Grill dish affecting thermostat	• Remove grill dish from oven on bake modes
Baked products too brown on top	Oven not preheated	• Preheat oven
	Baking tins too large for the recipe	• Use correct size tins
	Baking tins not evenly spaced	• Stagger baking tins at least 3cm between tins and oven walls
	Products not evenly sized or spaced on trays	• Make into same size and shape, and spread evenly over trays
	Baking temperature too high	• Lower the temperature
Baked products too brown on bottom	Baking tins too large for the recipe	• Use correct size tins
	Baking tins are a dark metal or glass	• Change to shiny, light tins or lower the temp by 10°C
	Food too low in the oven	• Cook one shelf higher
	Oven door opened too frequently during baking	• Don't open the door until at least half the cooking time has passed
	Baking temperature too high	• Lower the temperature
	Grill dish affecting thermostat	• Remove grill dish from oven on bake modes
Cakes have a cracked thin crust	Baking temperature too high	• Lower the temperature
	Food too high in oven	• Cook one shelf lower
	Cake batter over mixed	• Mix just long enough to combine ingredients
	Pan too deep	• Check size of pan
	Baking pans dark	• Change to shiny pans
Baked products are pale, flat and undercooked	Baking temperature too low	• Raise the temperature
	Food too low in oven	• Cook one shelf higher
	Baking time too short	• Increase the cooking time
	Incorrect size tin	• Use the correct size tin
Cakes fallen in the centre	Baking temperature too low	• Raise the temperature
	Baking time too short	• Increase the cooking time
	Proportions of ingredients incorrect	• Check recipe
	Door opened too early in baking	• Do not open door until the last quarter of cooking time
Roast meat, potatoes not browning in fan oven	Poor air circulation	• Elevate food onto a rack to allow air circulation
	Grill dish affecting thermostat	• Remove grill dish from oven on bake modes
	Juices running out of meat	• Do not pierce meat with a fork
Grilled meats outside is overcooked and centre is raw		• Grill at lower insert position
Grilled chops and steaks curling		• Cut into fat every 2cm
The steam cooking does not operate	There is no water in the tank	• Fill the water tank
	Limescale is obstructing the hole	• Check the steam outlet opening and remove the lime
It takes more than three minutes to empty the water tank or the water tank leaks from the steam outlet	There are lime deposits in the appliance	• Check the water tank and refer to the chapter on Cleaning the water tank.
Steam and condensation settle on the food and in the appliance	The dish has been left in the oven for too long	• Do not keep the dishes in the appliance for longer than 15-20 minutes after the cooking ends

CLEANING THE APPLIANCE

WARNING!

- **Do not use steam cleaners.**
- **Do not line the bottom of the oven with foil or cookware.**

Stainless steel

- All grades of stainless steel can stain, discolour or become greasy. You must clean these areas regularly by following the procedures below, if you want your appliance to look its best, perform well and have a long life.
- **Care must be taken when wiping exposed stainless steel edges, they can be sharp!**
- A suitable cleaner can be purchased from Electrolux Customer Care Centres.

CAUTION!

- The oven door and control panel are decorated with a special stainless steel that resists finger marks and should only be cleaned with warm water and a mild detergent.
- DO NOT use stainless steel cleaners, abrasive cleaners or harsh solvents.

Note: Make sure you follow the polish or brushing lines in the steel.

Glass

- Glass surfaces on doors and control panels are best cleaned immediately after soiling.
- A damp cloth may help remove baked on food deposits.
- Oven cleaners can be used to remove stubborn marks and stains.

WARNING!

- The door glass on this appliance is made from a tough, durable material that withstands heating and cooling without breaking. However, it must be remembered that it is GLASS, it may break. Treat it accordingly! Should you have any questions about the glass in your new appliance, please contact the customer care centre by dialling 1300 363 640.
- Do not use harsh abrasive cleaners or sharp metal scrapers to clean the oven door since they can scratch the surface, which may result in shattering of the glass.

Oven

- Always keep the appliance clean. Ensure fats and oils do not accumulate around elements, burners or fans.
- Always keep oven dish, bake trays and grill dish inserts clean, as any fat deposits may catch fire.
- It is recommended to wrap meats in foil or an oven roasting bag to minimise cleaning.
- Any polyunsaturated fats can leave a varnish-like residue which is very difficult to remove.

Grill

- Always keep grill dish and grill insert clean, as any fat deposits may catch fire.

CLEANING THE ACCESSORIES

Removing the trays and shelves from the appliance

1. Slide the dish and shelves towards you until they reach the front stop.
2. Tilt them up at the front to clear the side supports, taking care not to spill the contents.
3. Lift them clear.
4. Wash the dish and insert the shelves in hot soapy water.
5. Reverse the above steps to put the grill dish and shelves back again.
6. Ensure that they are placed between two support wires.
7. To remove a tray from a sliding position:
 - Pull tray towards you until it stops.
 - Lift the tray clear.

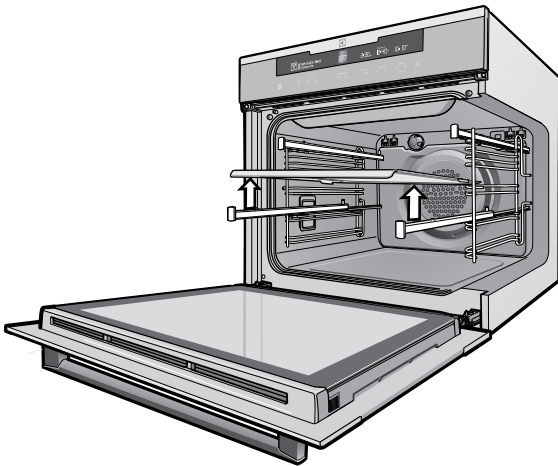

Removing the side racks

1. Grasp the middle wire at the front.
2. Pull firmly inwards.

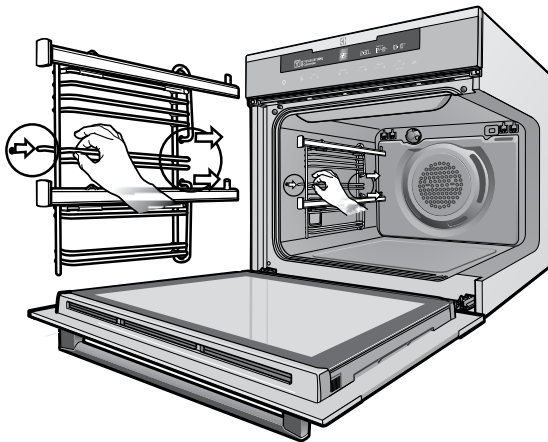

Removing and replacing the oven back light and side light (if fitted)

- Turn oven light glass anticlockwise to remove it for globe replacement.
- To remove side light, place a spoon under the light glass and lever off. Replace globe and snap glass cover back into position.
- A special high temperature resistant globe should be used. This can be purchased from Electrolux Customer Care Centre.

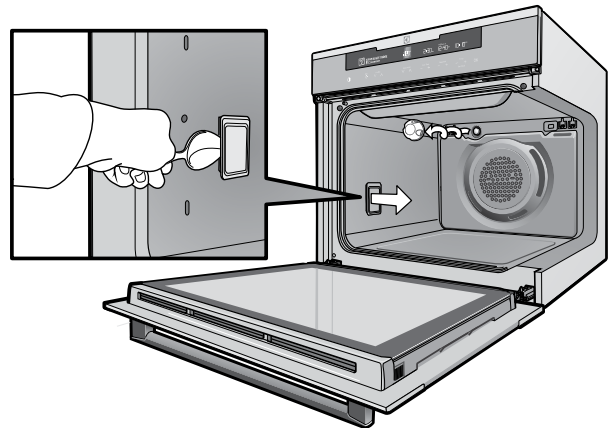

Releasing the grill element

To clean the oven roof rotate latch until the element drops down freely .

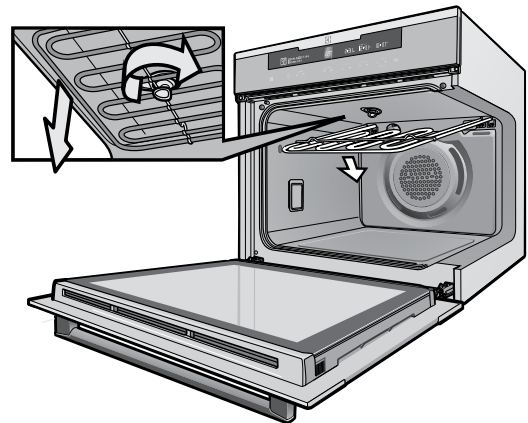

WARNING!

Make sure the appliance is turned off before you remove or replace parts, to avoid the possibility of electric shock.

CLEANING THE ACCESSORIES

Catalytic self cleaning panels (if fitted)

Operation

Catalytic self clean panels are coated with a specially formulated enamel coating, over a base of regular enamel. This enamel coating has a rough surface which is also porous. During normal cooking, fats and other food splatter is partially absorbed into the surface and then oxidises away.

This oxidation of the fat works best if the oven is set at high temperatures. You will find that if you do a lot of lower temperature baking, say around the normal 180°C, then the cleaning process may not be complete. Every now and then you should turn the oven on to 250°C for around one hour to completely remove the soil.

Cleaning

Should the panels become heavily soiled, they will need to be taken out of the oven and cleaned by hand. They should be soaked in warm, soapy water for at least 2 hours and then wiped clean with a soft cloth.

Note: It is not recommended that the catalytic liner in the top of the oven be removed.

CAUTION!

Solid cleaning powders, creamy cleansers, caustic oven cleaners, steel wool or other scourers will ruin the catalytic surface and must NEVER BE USED.

Removing catalytic liners

- Remove the side racks (see previous page)
- Lift the liner up to disengage the hooks.
- The liners should now be free to be pulled in towards the centre of the oven.

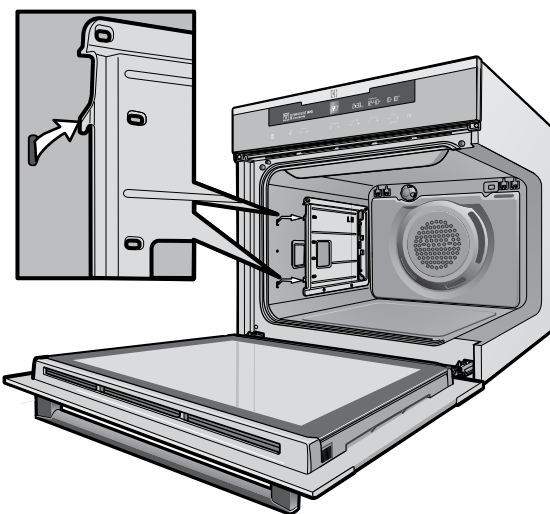

CLEANING THE TRIPLE GLAZED DOOR

! WARNING!

Do not lift the door by the handle. Rough handling will cause glass to break.

Removing the oven door

The oven is equipped with a door that can be disassembled in order to clean all the panes of glass.

Remove the door before cleaning.

- Open the door fully to access the hinges then rotate the 'stirrups' (highlighted in the image) on both hinges fully towards the oven.

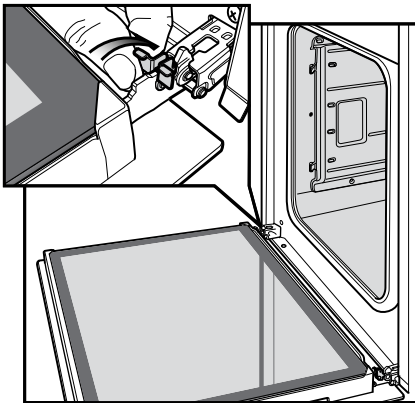

- Slowly close the oven door until it stops against the 'stirrups' (about 45°).

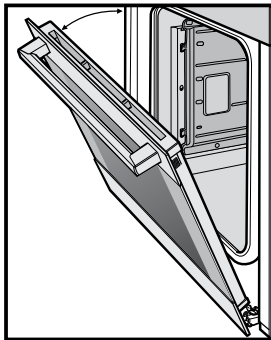

- Grasp the oven door with a hand each side of the door and remove it from the oven by pulling it towards you.

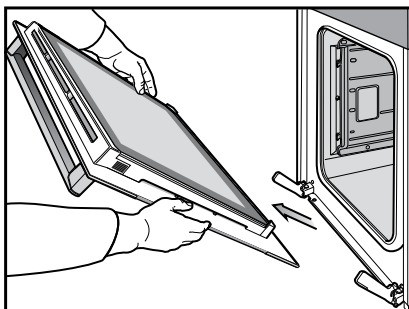

- Lay the oven door with the outer side facing downwards on something soft and flat (for example a blanket on a kitchen table) to prevent scratches.

Removing the oven door top trim

- Take hold of the grid embossed sections of the door trim at each end and press inwards to release the clips. Remove the door trim by pulling it towards you.

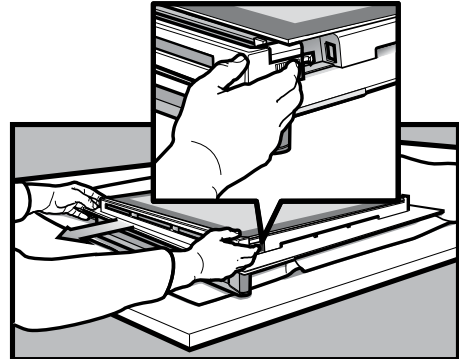

Removing door glass panels

! WARNING!

Rough handling, especially around the edges can cause the glass to break.

- Lift the black bordered glass panel out of the guide.
- Repeat this for the smaller clear glass panel.

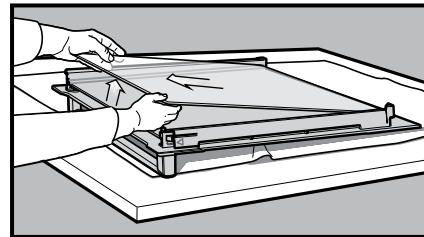

Cleaning the door glass panels

! CAUTION!

- Do not to use harsh abrasives on the glass panes as the reflective surface plays a role in the function of the oven
- Do not place glass in dishwasher. Hand wash only with a soft cloth and warm soapy water. When dry polish with a soft cloth and ensure the glass is dry before reassembly.

CLEANING THE TRIPLE GLAZED DOOR

Replacing the door glass panels

- Insert the smaller clear glass panel first from above and at an angle to the profile of the door.

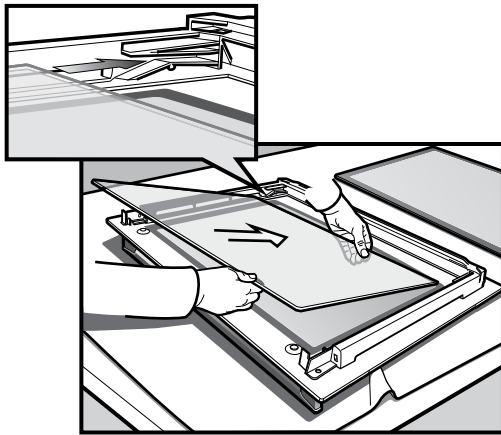

- Repeat for the black bordered glass panel ensuring the painted surface is facing to the downside.

Replacing the top door trim

- Take hold of the top door trim at each side and position it to the inside edge of the glass.
- Push the trim down with its top edge over glass panel until the clip snaps in on each side of the trim.

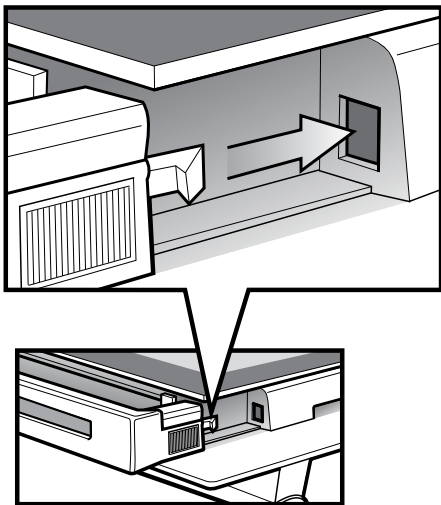

- Push the middle of the trim down to ensure it is straight and firm against the glass panel.

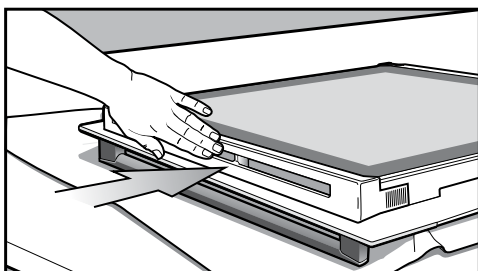

Fitting the oven door

- Take hold of the oven door with a hand on each side and with the door at an angle of 45°, position the recesses at the bottom of the door onto the hinge arms of the oven. Let the door slide down the hinge arms as far as it will go.

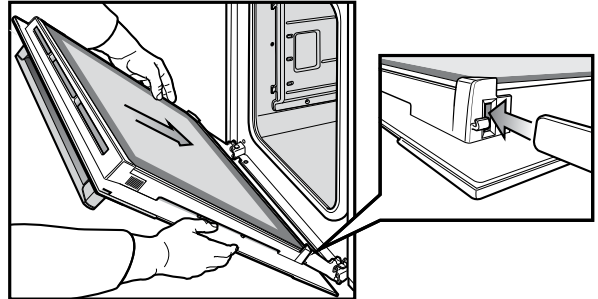

- Open the door fully to access the hinges.
- Rotate the 'stirrups' (see the image below) until they lock into the hook. The oven door may now be closed.

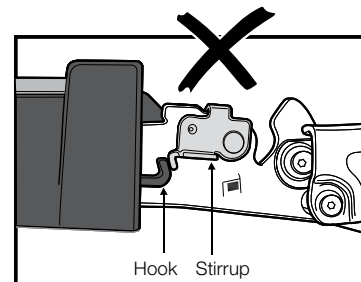
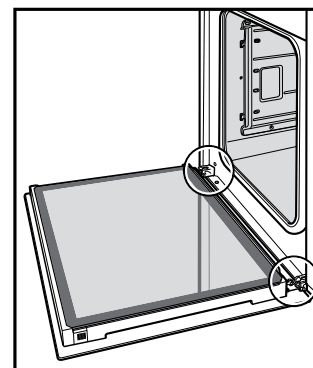
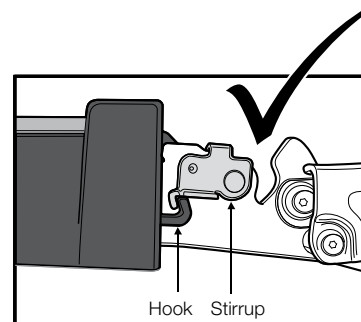

CLEANING THE QUAD GLAZED DOOR

! WARNING!

Do not lift the door by the handle. Rough handling will cause glass to break.

Removing the oven door

The oven is equipped with a door that can be disassembled in order to clean the panes of glass.

Positioning the door for dismantling

The door needs to be positioned at an angle to aid in the disassembly of the panes.

- Open the door fully and flip out the hinge locating tab to the open position.

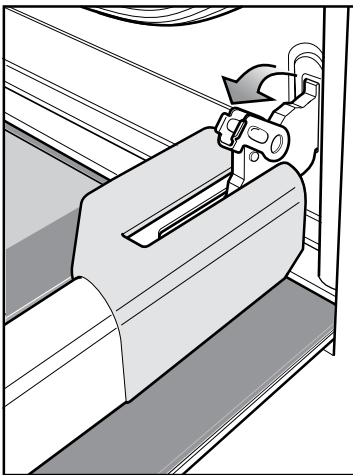

- After the locating tab has been positioned, gently close the oven door until it stops on the locating tab. The door is now ready for dismantling.

Removing the top door trim

- Push in the 2 buttons on either side of the trim.
- Lift the trim away from the door.

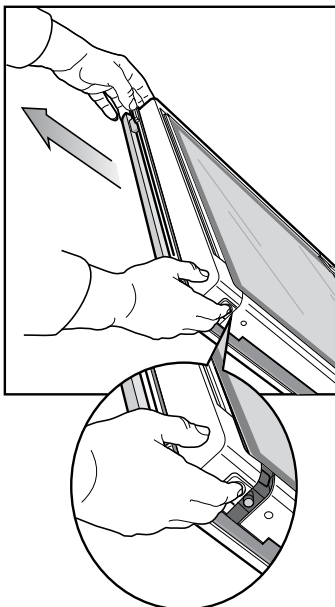

Removing the glass panes

- Remove the 3 panes of glass starting with pane 1.
- When removing pane 3 ensure that the 2 rubber supports are removed before cleaning.

Do not misplace them!

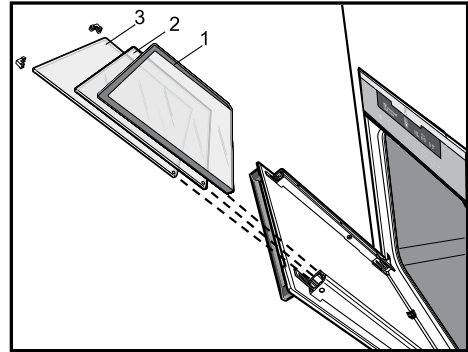

Cleaning the glass panes

Clean with a damp cloth.

Do not use scouring agents or abrasive sponges as these could damage the reflective surface.

Dry thoroughly before reassembly.

Replacing the glass panes

- Replace the glass panes back into the door starting with pane 3.
- Ensure this pane is placed into the correct slot and that the 2 rubber supports are in place.
- Next replace pane 2. There is a reflective coating on this pane. This coating is indicated by a circle printed on its surface. Ensure this circle is in the same corner as pictured below.

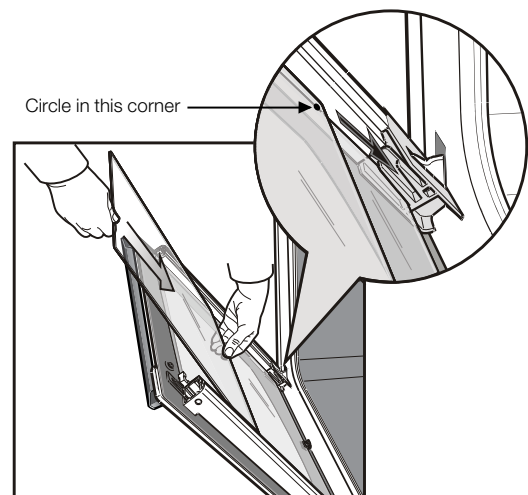

- Replace pane 1 ensuring the black screening is facing inward towards the oven.

Replacing the top door trim

Replace the trim ensuring the clips snap into the 2 location holes. Flip the hinge locating tab back into its original position and close the door.

TIPS AND TROUBLESHOOTING

IMPORTANT!

Cooling/vent fan

This appliance is fitted with a cooling fan. This prevents your kitchen cabinet from overheating and reduces the condensation inside the oven. It will operate whenever you are using the oven and blow warm air across the top of the oven door.

Note: If the oven is still hot from cooking, the cooling fan will keep running to cool the oven down and will switch off by itself once cool.

CAUTION!

Using the oven

- Always cook with the oven door closed.
- Stand clear when opening the drop down oven door. Do not allow it to fall open. Always support the door using the door handle until it is fully open.
- Do not lean on an open oven door, or place heavy items on it. This could damage the appliance. Take care in the region of the hinges.

IMPORTANT!

Condensation and steam

This appliance is supplied with an exclusive system which produces a natural circulation of air and the constant recycling of steam.

This steam makes it possible to cook in a steamy environment ensuring that dishes are soft inside and crusty on the outside. This process also reduces cooking time and energy consumption. During cooking steam may be produced and released when the door is opened. This is absolutely normal.

When food is heated it produces steam in the same way a boiling kettle does. When steam comes into contact with the oven door glass it will condense and produce water droplets. To reduce condensation, ensure that the oven is well heated before placing food in the oven cavity.

Oven pre-heating is necessary before any cooking.

It is recommended that condensation is wiped away after each use of the oven.

The effects of dishes on cooking results

Dishes and tins vary in their thickness, conductivity, colour etc. which affects the way they transfer heat to the food inside them.

- Aluminium, earthenware, oven glassware and bright shiny utensils reduce cooking and base browning.
- Enamelled cast iron, anodized aluminium, aluminium with non-stick interior and coloured exterior and dark, heavy utensils increase cooking and base browning.
- To increase base browning simply lower the shelf position. To increase top browning, raise the shelf position.
- Always place dishes centrally on the shelf to ensure even browning.
- Single level cooking gives best results in conventional modes. If cooking on more than one level use the fan cooking function.

TROUBLESHOOTING

Faults

If there is a problem with the oven or grill, please check the points listed below before calling for service. It may be possible to avoid a call by fixing the problem yourself - and so continue cooking.

Note: We may charge for service even in the guarantee period if your problem is due to the causes listed below.

problem	possible cause
Oven or grill not working	<ul style="list-style-type: none"> • Time of day is not set • Power is not turned on • Controls are incorrectly set • Oven is in 'Demo' mode, refer to Additional Functionality • Household fuse has blown or power supply is off. (If the household fuse continues to blow, call the Service Centre) • Child-proof oven lock is activated. 'LOCKED' is displayed when control is touched. (Refer to operating instructions)
Oven light not working	<ul style="list-style-type: none"> • Light may be turned off at control panel • Lamp blown or loose socket • Household fuse has blown. (If the household fuse continues to blow, call the Service Centre)
Oven not heating enough	<ul style="list-style-type: none"> • Foil trays on bottom of oven • Timer is in 'AUTO' mode. (Refer to operating instructions) • Household fuse has blown or power supply is off. (If the household fuse continues to blow, call the Service Centre)
Clock flashing on display	<ul style="list-style-type: none"> • Reset time of day and any cooking functions you were using.
Unit smoking when first used	<ul style="list-style-type: none"> • Protective oils being removed
Condensation build up	<ul style="list-style-type: none"> • Reduce the amount of water used in cooking. (Sometimes condensation is normal)
Door cannot be replaced after removal	<ul style="list-style-type: none"> • Stirrup not engaged properly
Pyrolytic cycle not working	<ul style="list-style-type: none"> • All accessories must be removed from the ovens.
Functions and temperature appear on display but oven does not work	<ul style="list-style-type: none"> • Oven is in 'Demo' mode, refer to Additional Functionality
When the door is open the fan stops (underbench only)	<ul style="list-style-type: none"> • This is a function of the power board to help reduce the blast of air when opening the door.
When a non fan mode is selected the fan starts	<ul style="list-style-type: none"> • Most oven modes have a fast heat up function that uses the fan, fan element and top (boost) elements. Auto fast heat up can be overridden by selecting a temperature of 120°C or less, allowing the function to start, then increasing the temperature to the desired level
The light stays on when the door is closed	<ul style="list-style-type: none"> • An oven function has been selected. • The light has been turned on at the control panel
The light does not turn *ON* when the door is opened	<ul style="list-style-type: none"> • Oven light may need replacing.

Data plate

When you need information, service or spare parts please be prepared to tell us the:

- Model number
- Serial number

These are shown on the data plate. The data plate is visible when the oven or grill door is open.

Customer Care Centre

If you need more information, please contact the Customer Care Centre:

Australia – 1300 363 640, 8am-5pm EST Mon-Fri.

New Zealand – +649 573 2384, 8am-5pm EST Mon-Fri.

If you have a warranty or spare parts enquiry, you should call the number listed on the back page.

INSTALLATION OF THE APPLIANCE

! WARNING!

To avoid any potential hazard, you must follow our instructions when you install your appliance. Failure to install the appliance correctly could invalidate any warranty or liability claims and lead to prosecution.

Use an authorised person

- As stated in the local municipal building codes and other relevant statutory regulations:
- Wiring connections must be in accordance with AS/NZS 3000 Wiring Rules and any particular conditions of the local authority.
- Refer to data plate for rating information. The data plate is positioned behind the bottom of the oven door. The circuit diagram is positioned on the top panel of the appliance.
- For appliances with open cooking surfaces, an all pole disconnect functional switch should be provided near the appliance in an accessible position. Refer to AS/NZS 3000 clause 4.7.1
- Wiring should be protected against mechanical failure. Refer to AS/NZS3000 clauses 3.3.2.6, 3.9, 3.10
- A means of disconnection with a contact separation of at least 3mm must be supplied in the fixed wiring.

! WARNING!

This appliance must be properly earthed.

- Do not lift the appliance by the door handles.
- Prepare the cupboard opening to match your appliance measurements. (See diagrams)
- Slide appliance into the cupboard, ensuring that the supply cable (where fitted) does not kink.
- To prevent tipping, use the screws supplied to secure your oven into the cupboard by fastening through the 2 holes to the front panel.
- Where the appliance is built into a cabinet, the cabinet must be capable of withstanding 70°C. Installation into low temperature tolerant cabinetry (e.g. Vinyl coated) may result in deterioration of the low temperature coating by discolouring or bubbling.
- If the appliance is to be installed adjacent to vinyl wrapped surfaces, use an installation kit available from the vinyl-wrap supplier.
- Electrolux Home Products cannot accept responsibility for damage caused by installation into low temperature tolerant cabinets.
- After installation, test and ensure that the appliance operates correctly before handing it over to the customer.

Note: If a powerpoint is fitted it must be accessible with the appliance installed, as the plug must be accessible after installation.

Cabinet construction for your appliance

For the best integration within a kitchen, install this appliance in a standard 600mm wide cupboard that gives a flush fit with the surrounding cupboard fronts. It can also be installed using a proud fit.

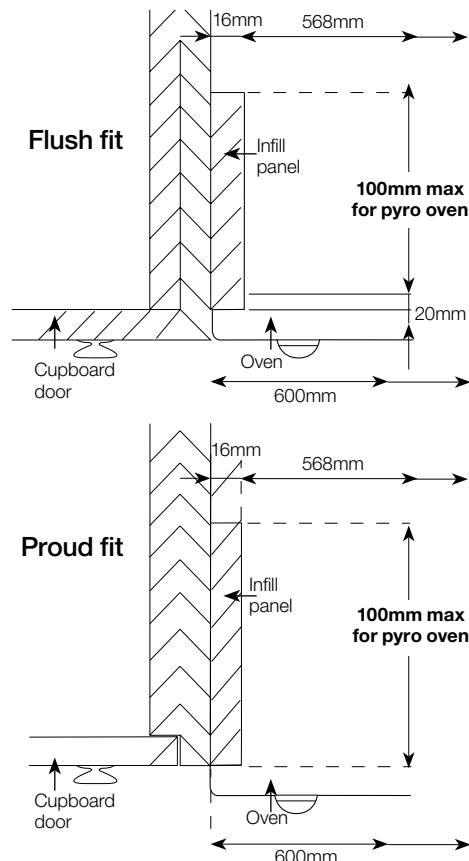

Note: Your appliance must be mounted on a flat surface for the full width and depth of the product

i IMPORTANT!

The infill panel **MUST** not exceed 100mm in length to ensure a 16mm gap is maintained.

INSTALLATION OF THE APPLIANCE

Underbench oven

Your underbench oven looks best when the control panel is directly under the benchtop. An upper infill panel may be added if the cooktop placed above the benchtop is too deep. Refer to cooktop installation instructions for required clearance between cooktop and oven.

Cut-out dimensions

type of fit	A (width)	B (height)	C (depth)
Flush fit (mm)	600	600	581 min.
Proud fit (mm)	568	590	560 min.

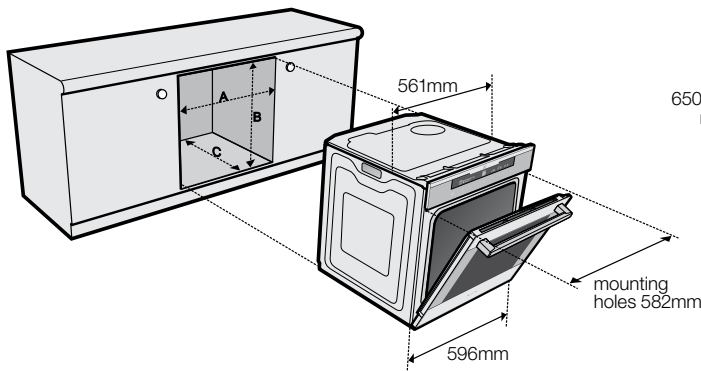

Pyrolytic underbench cut-out dimensions

type of fit	A (width)	B (height)	C (depth)	D*
Flush fit (mm)	600	600	581 min.	20
Proud fit (mm)	568	590	560 min.	20

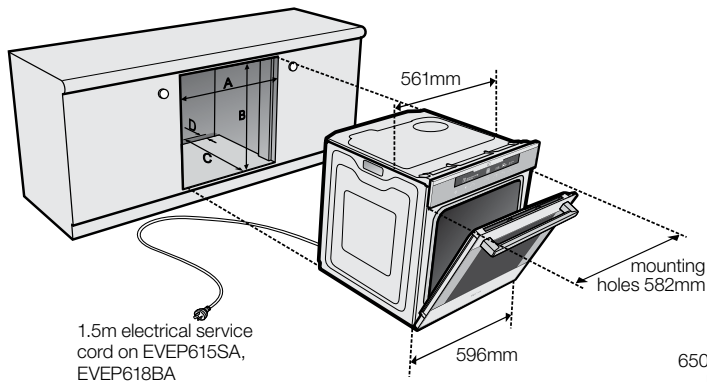

Note: Dimension 'D'.

For proper ventilation there must be a gap at the bottom rear of the cabinet. This can be a slot 20mm deep or an equivalent, full width opening (e.g. a series of holes) with a min area of 120cm². The opening must be clear of the product when fully installed. This is a requirement any EVEPxxxx model.

Power point connection for the EVEP615SA and EVEP618BA must be accessible with the appliance fully installed. If the supply cord is damaged it must be replaced by the manufacturer, its service agent or similarly qualified persons in order to avoid a hazard.

Duo oven Cut-out dimensions

type of fit	A (width)	B (height)	C (depth)
Flush fit (mm)	600	893	581 min.
Proud fit (mm)	568	885	560 min.

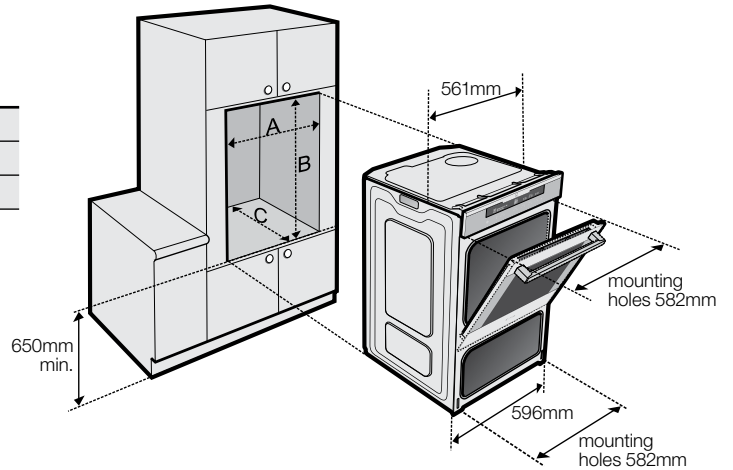

Double oven Cut-out dimensions

type of fit	A (width)	B (height)	C (depth)
Flush fit (mm)	600	1086	581 min.
Proud fit (mm)	568	1078	560 min.

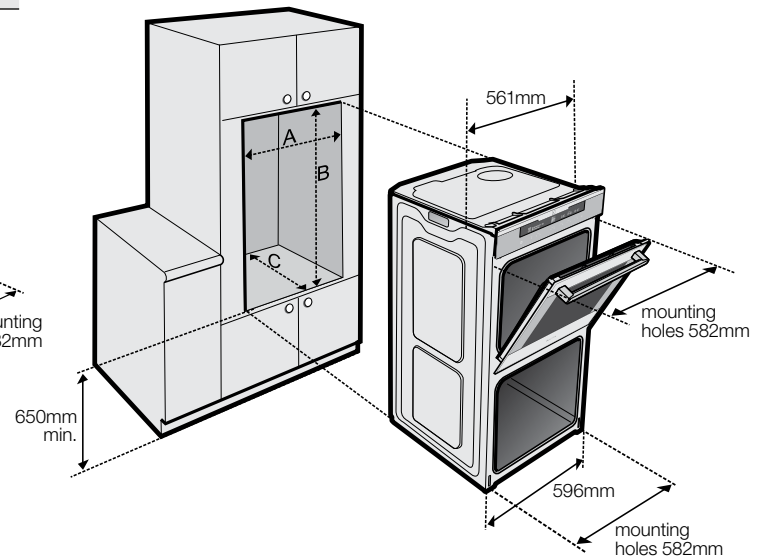

TECHNICAL SPECIFICATIONS

model	product dimensions (h x w x d) mm	electrical connection	min. fuse rating	max. power rating	max. current rating
EVE611SA	597 x 596 x 573	230-240V/50Hz	16A	3.1kW	12.9A
EVE613SA	597 x 596 x 573	230-240V/50Hz	16A	3.1kW	12.9A
EVE614BA	597 x 596 x 573	230-240V/50Hz	16A	3.1kW	12.9A
EVE616BA	597 x 596 x 573	230-240V/50Hz	16A </td <td>3.1kW</td> <td>12.9A</td>	3.1kW	12.9A
EVEP611SA	597 x 596 x 573	230-240V/50Hz	16A	3.1kW	12.9A
EVEP614BA	597 x 596 x 573	230-240V/50Hz	16A	3.1kW	12.9A
EVEP613SA	597 x 596 x 573	230-240V/50Hz	16A	3.1kW	12.9A
EVEP616BA	597 x 596 x 573	230-240V/50Hz	16A	3.1kW	12.9A
EVEP615SA	597 x 596 x 573	230-240V/50Hz	16A	3.5kW	12.9A
EVEP618BA	597 x 596 x 573	230-240V/50Hz	16A	3.5kW	12.9A
EVE623SA	890 x 596 x 573	230-240V/50Hz	25A	5.3kW	22.1A
EVE633SA	1083 x 596 x 573	230-240V/50Hz	25A	6.2kW	24.2A

Hard wiring details

1. Remove terminal cover plate from rear panel of appliance.
2. Fit wires through hole in cover plate and make connections to terminals.
3. Engage wires into plastic clip. Secure plastic clip with two long silver screws (supplied in separate bag).
4. Replace cover plate onto rear panel.

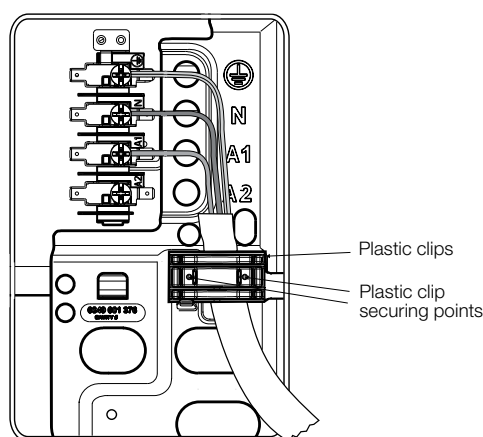

Error codes

error code	description	comment	fix
F01 or 01	Door lock sensor alarm	This relates to a door lock failure which is only associated with the Pyrolytic product	Check wiring/plugs or replace door lock
F02 or 02	Door lock actuator alarm		
F04 or 04	Oven Probe (PT500) out	This relates to the temperature sensing probe which may be out of tolerance, of range alarm or have open/short circuit connections	Replace probe
F05 or 05	Oven Probe (PT500) too high temperature alarm		
25	Board Temperature Sensor (NTC) too high temperature alarm	This relates to the temperature of the powerboard and/or the (NTC) on the powerboard	Cooling fan not working or replace powerboard
26	Board Temperature Sensor (NTC) out of range warning		
6	Board Temperature Sensor (NTC) out of range alarm		
F08 or 08	Communication alarm	This relates to an error in communication between the powerboard and the IOI controller. This can occur if the IOI controller is connected while the powerboard is energised	Reset power. (Minimum of 20 sec.) or check or replace data cable
F09 or 09	Software compatibility code alarm	This relates to a mismatch between powerboard firmware version and the IOI controller firmware version. Most likely caused by an un-programmed powerboard	Replace Powerboard
C1	Telescopic runners fitted	Only applies to Pyrolytic product	Remove both side racks and re-start pyrolytic cycle
C3	Door open	Only applies to Pyrolytic product	Close door and restart pyrolytic cycle
F03 or 03	EEPROM check sum alarm	Relates to the controller	Replace Controller
F14 or 14	EEPROM compatibility code alarm	Relates to the controller	Replace Controller

Electrolux Warranty

FOR SALES IN AUSTRALIA AND NEW ZEALAND
APPLIANCE: BUILT-IN OVEN, COOKTOP
AND FREESTANDING COOKER

This document sets out the terms and conditions of the product warranties for Electrolux Appliances. It is an important document. Please keep it with your proof of purchase documents in a safe place for future reference should you require service for your Appliance.

1. In this warranty
 - (a) 'acceptable quality' as referred to in clause 10 of this warranty has the same meaning referred to in the ACL;
 - (b) 'ACL' means Trade Practices Amendment (Australian Consumer Law) Act (No.2) 2010;
 - (c) 'Appliance' means any Electrolux product purchased by you accompanied by this document;
 - (d) 'ASC' means Electrolux' authorised serviced centres;
 - (e) 'Electrolux' means Electrolux Home Products Pty Ltd of 163 O'Riordan Street, Mascot, NSW 2020, ABN 51 004 762 341 in respect of Appliances purchased in Australia and Electrolux (NZ) Limited of 3-5 Niall Burgess Road, Mount Wellington, in respect of Appliances purchased in New Zealand;
 - (f) 'major failure' as referred to in clause 10 of this warranty has the same meaning referred to in the ACL and includes a situation when an Appliance cannot be repaired or it is uneconomic for Electrolux, at its discretion, to repair an Appliance during the Warranty Period;
 - (g) 'Warranty Period' means:
 - (i) where the Appliance is used for personal, domestic or household use (i.e. normal single family use) as set out in the instruction manual, the Appliance is warranted against manufacturing defects in Australia for 24 months and in New Zealand for 24 months, following the date of original purchase of the Appliance;
 - (ii) where the Appliance is used for commercial purposes (including being used to directly assist a business or where the Appliance is used in a multi-family communal or share type environment), the Appliance will then be warranted against manufacturing defects in Australia for 3 months and in New Zealand for 3 months, following the date of original purchase of the Appliance.
 - (h) 'you' means the purchaser of the Appliance not having purchased the Appliance for re-sale, and 'your' has a corresponding meaning.
2. This warranty only applies to Appliances purchased and used in Australia or New Zealand and is in addition to (and does not exclude, restrict, or modify in any way) any non-excludable statutory warranties in Australia or New Zealand.
3. During the Warranty Period Electrolux or its ASC will, at no extra charge if your Appliance is readily accessible for service, without special equipment and subject to these terms and conditions, repair or replace any parts which it considers to be defective. Electrolux or its ASC may use remanufactured parts to repair your Appliance. You agree that any replaced Appliances or parts become the property of Electrolux. This warranty does not apply to light globes, batteries, filters or similar perishable parts.
4. Parts and Appliances not supplied by Electrolux are not covered by this warranty.
5. You will bear the cost of transportation, travel and delivery of the Appliance to and from Electrolux or its ASC. If you reside outside of the service area, you will bear the cost of:
 - (a) travel of an authorised representative;
 - (b) transportation and delivery of the Appliance to and from Electrolux or its ASC,

In all instances, unless the Appliance is transported by Electrolux or an Electrolux authorised representative, the Appliance is transported at the owner's cost and risk while in transit to and from Electrolux or its ASC.
6. Proof of purchase is required before you can make a claim under this warranty.
7. You may not make a claim under this warranty unless the defect claimed is due to faulty or defective parts or workmanship. Electrolux is not liable in the following situations (which are not exhaustive):
 - (a) the Appliance is damaged by:
 - (i) accident
 - (ii) misuse or abuse, including failure to properly maintain or service
 - (iii) normal wear and tear
 - (iv) power surges, electrical storm damage or incorrect power supply
 - (v) incomplete or improper installation
 - (vi) incorrect, improper or inappropriate operation
 - (vii) insect or vermin infestation
 - (viii) failure to comply with any additional instructions supplied with the Appliance;
 - (b) the Appliance is modified without authority from Electrolux in writing;
 - (c) the Appliance's serial number or warranty seal has been removed or defaced;
 - (d) the Appliance was serviced or repaired by anyone other than Electrolux, an authorised repairer or ASC.
8. This warranty, the contract to which it relates and the relationship between you and Electrolux are governed by the law applicable where the Appliance was purchased. Where the Appliance was purchased in New Zealand for business purposes the Consumer Guarantee Act does not apply.
9. To the extent permitted by law, Electrolux excludes all warranties and liabilities (other than as contained in this document) including liability for any loss or damage whether direct or indirect arising from your purchase, use or non use of the Appliance.
10. For Appliances and services provided by Electrolux in Australia, the Appliances come with a guarantee by Electrolux that cannot be excluded under the Australian Consumer Law. You are entitled to a replacement or refund for a major failure and for compensation for any other reasonably foreseeable loss or damage. You are also entitled to have the Appliance repaired or replaced if the Appliance fails to be of acceptable quality and the failure does not amount to a major failure. The benefits to you given by this warranty are in addition to your other rights and remedies under a law in relation to the Appliances or services to which the warranty relates.
11. At all times during the Warranty Period, Electrolux shall, at its discretion, determine whether repair, replacement or refund will apply if an Appliance has a valid warranty claim applicable to it.
12. For Appliances and services provided by Electrolux in New Zealand, the Appliances come with a guarantee by Electrolux pursuant to the provisions of the Consumer Guarantees Act, the Sale of Goods Act and the Fair Trading Act.
13. To enquire about claiming under this warranty, please follow these steps:
 - (a) carefully check the operating instructions, user manual and the terms of this warranty;
 - (b) have the model and serial number of the Appliance available;
 - (c) have the proof of purchase (eg an invoice) available;
 - (d) telephone the numbers shown below.
14. You accept that if you make a warranty claim, Electrolux and its ASC may exchange information in relation to you to enable Electrolux to meet its obligations under this warranty.

Important Notice

Before calling for service, please ensure that the steps listed in point 13 above have been followed.

<p>FOR SERVICE or to find the address of your nearest state service centre in Australia PLEASE CALL 13 13 49 For the cost of a local call (Australia only)</p>	<p>SERVICE AUSTRALIA  ELECTROLUX HOME PRODUCTS www.electrolux.com.au</p>	<p>FOR SPARE PARTS or to find the address of your nearest state spare parts centre in Australia PLEASE CALL 13 13 50 For the cost of a local call (Australia only)</p>
<p>FOR SERVICE or to find the address of your nearest authorised service centre in New Zealand FREE CALL 0800 10 66 10 (New Zealand only)</p>	<p>SERVICE NEW ZEALAND  ELECTROLUX HOME PRODUCTS www.electrolux.co.nz</p>	<p>FOR SPARE PARTS or to find the address of your nearest state spare parts centre in New Zealand FREE CALL 0800 10 66 20 (New Zealand only)</p>

Electrolux Home Products Australia

telephone: 1300 363 640
fax: 1800 350 067
email: customercare@electrolux.com.au
web: www.electrolux.com.au

Electrolux Home Products New Zealand

telephone: 09 573 2384
fax: 09 573 2221
email: customercare@electrolux.co.nz
web: www.electrolux.co.nz

The Thoughtful Design Innovator.

Do you remember the last time you opened a gift that made you say 'Oh! How did you know? That's exactly what I wanted!' That's the kind of feeling that the designers at Electrolux seek to evoke in everyone who chooses or uses one of our products. We devote time, knowledge, and a great deal of thought to anticipating and creating the kind of appliances that our customers really need and want.

This kind of thoughtful care means innovating with insight. Not design for design's sake, but design for the user's sake. For us, thoughtful design means making appliances easier to use and tasks more enjoyable to perform, freeing our customers to experience that ultimate 21st century luxury, ease of mind. Our aim is to make this ease of mind more available to more people in more parts of their everyday lives, all over the world. So when we say we're thinking of you, you know we mean just that.

The 'Thinking of you' promise from Electrolux goes beyond meeting the needs of today's consumers. It also means we're committed to making appliances safe for the environment—now and for future generations.

Electrolux. Thinking of you.

Share more of our thinking at www.electrolux.com.au or www.electrolux.co.nz

P/No. 0342 001 584

© 2013 Electrolux Home Products Pty Ltd
ABN 51 004 762 341

EMAN_Ovens_Aug13