



# FROST ICE CREAM & FROZEN DRINK MAKER **USER GUIDE**

# IMPORTANT SAFEGUARDS

**When using an electrical appliance, basic safety precautions should always be followed to reduce the risk of fire, electric shock, and/or injury, including the following:**

1. **Read all instructions before using.**
2. If the supply cord is damaged, it must be replaced by the manufacturer or its service agent or a similarly qualified person in order to avoid a hazard.
3. This appliance is not intended for use by persons (including children) with reduced physical, sensory or mental capabilities, or lack of experience and knowledge, unless they have been given supervision or instruction concerning use of the appliance by a person responsible for their safety. Children should be supervised to ensure that they do not play with the appliance.
4. This appliance can be used by children aged from 8 years and above and persons with reduced physical, sensory or mental capabilities or lack of experience and knowledge if they have been given supervision or instruction concerning use of the appliance in a safe way and understand the hazards involved. Children shall not play with the appliance. Cleaning and user maintenance shall not be made by children without supervision.

## **WARNING:**

- Do not store explosive substances such as aerosol cans with a flammable propellant in this appliance.
- Keep ventilation openings, in the appliance enclosure or in the built-in structure, clear of obstruction.
- Do not use mechanical devices or other means to accelerate the defrosting process, other than those recommended by the manufacturer.
- Do not damage the refrigerant circuit.
- Do not use electrical appliances inside the food storage compartments of the appliance, unless they are of the type recommended by the manufacturer.
- When positioning the appliance, ensure the supply cord is not trapped or damaged.

- Do not locate multiple portable socket-outlets or portable power supplies at the rear of the appliance.
- When disposing of the appliance, do so only at an authorized waste disposal center. Do not expose to flame.

## **DANGER:**

- Risk of fire or explosion. Flammable refrigerant used. Do not use mechanical devices to defrost refrigerator. Do not puncture refrigerant tubing.
- Risk of fire or explosion. Flammable refrigerant used. To be repaired only by trained service personnel. Use only manufacturer-authorized service parts. Any repair equipment used must be designed for flammable refrigerants. Follow all manufacturer repair instructions. Do not puncture refrigerant tubing.

## **CAUTION:**

- Risk of fire or explosion. Dispose of refrigerator properly in accordance with the applicable federal or local regulations. Flammable refrigerant used.
- Risk of fire or explosion due to puncture of refrigerant tubing; follow handling instructions carefully. Flammable refrigerant used.



The refrigerant (R290) is flammable.

- Risk of fire/Flammable materials.

The refrigerant isobutene (R290) is contained within the refrigerant circuit of the appliance, a natural gas with a high level of environmental compatibility, which is nevertheless flammable. During transportation and installation of the appliance, ensure that none of the components of the refrigerant circuit becomes damaged. Refrigerant is flammable gas, do not expose to open flame. When disposing of this equipment, be sure to dispose of it at an authorized waste disposal center.

If the refrigerant circuit should be damaged:

- Avoid opening flames and sources of ignition.
- Thoroughly ventilate the room in which the appliance is situated.
  1. Do not use outdoors.
  2. This appliance is intended to be used in household and similar applications such as:
    - Staff kitchen areas in shops, offices and other working environments;
    - Farm houses and by clients in hotels, motels and other residential type environments;
    - Bed and breakfast type environments.
    - Catering and similar non retail applications.

1. Before using the appliance for the first time, please wait 2 hours after positioning it, and keep the transparent lid open for at least 2 hours.
2. Ensure the voltage is compliant with the voltage range stated on the rating label, and ensure the earthing of the socket is in good condition.
3. Do not upend this product or incline it over a 45° angle.
4. To protect against risk of electric shock, do not pour water on cord, plug and ventilation, immerse the appliance in water or any other liquid.
5. The plug must be removed before cleaning, maintaining or filling the appliance.
6. Keep the appliance 20cm from other objects to ensure the good heat releasing.
7. Do not use the accessories which are not recommended by Manufacturer.
8. Do not use the appliance close by flames, hot plates or stoves.
9. Do not switch on the power button frequently (ensure 5 min. interval at least) to avoid the damage of compressor.
10. Do not use outdoors.
11. Never clean with scouring powders or hard implements.
12. Please keep the instruction manual.
13. Do not put your fingers into the outlet to avoid danger.
14. If the SUPPLY CORD is damaged, it must be replaced by the manufacturer, its service agent or similarly qualified persons in order to avoid a hazard.
15. If there is a fault, please check it again before requesting maintenance. If the fault still cannot be eliminated, please go to the designated maintenance point for maintenance, or contact our company, and please confirm the following items.

# SAVE THESE INSTRUCTIONS FOR HOUSEHOLD USE ONLY

## **SPECIAL CORD SET INSTRUCTIONS:**

A short power-supply cord is provided to reduce the risks resulting from becoming entangled in or tripping over a longer cord. Longer extension cords may be used if care is exercised. If a long extension cord is used, the marked electrical rating of the extension cord should be at least as great as the electrical rating of the appliance, and the longer cord should be arranged so that it will not drape over the countertop or tabletop where it can be pulled on by children or animals or tripped over.

# NO FREEZER, NO WAITING, NO HASSLE.

Welcome to the GreenPan Frost Ice Cream and Frozen Drink Maker, the easiest way to bring frozen treats home! We have helpful tips, tricks, and quick recipes to help you get started creating your favorite slushie or frozen cocktail, homemade ice cream, or creamy milkshakes. **Enjoy!**

## CONTENTS

- 05 **Before First Use**
- 05 **Parts**
- 05 **Control Panel**
- 06 **Assembly**
- 07 **Operation**
- 10 **Quick Tips**
- 11 **Cleaning & Maintenance**
- 12 **Troubleshooting**
- 13 **Warranty**

## BEFORE FIRST USE

1. Read all instructions and important safeguards.
2. Remove all packaging materials and check that all items have been received in good condition.
3. Tear up all plastic bags and dispose of properly as they can pose a suffocation or choking risk to children.
4. Wash all accessories in warm, soapy water. Rinse and dry thoroughly.

**NOTE:** Do not use harsh abrasive cleaners. If washing accessories in the dishwasher, a slight discoloration to accessories may occur. This is cosmetic only and will not affect performance.

## PARTS

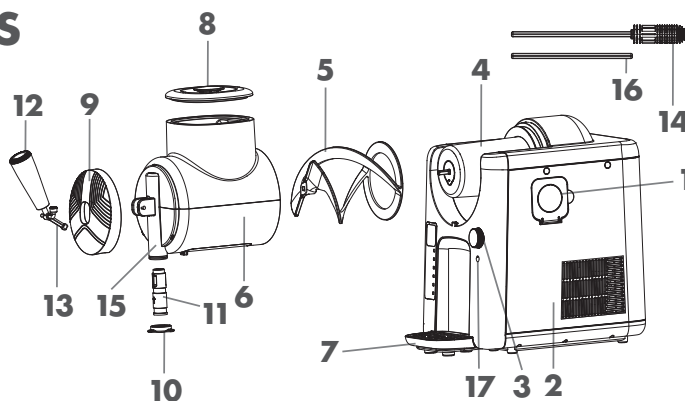

- |                          |                                 |                         |
|--------------------------|---------------------------------|-------------------------|
| 1. Ice Cream Cone Holder | 7. Two-Part Removable Drip Tray | 13. Handle Fixing Pin   |
| 2. Main Body             | 8. Mixing Bowl Cover            | 14. Cleaning Brush      |
| 3. Control Dial          | 9. Removable Decorative Cover   | 15. Extrusion Head Slot |
| 4. Cooling Rod           | 10. Extrude Cover Accessory     | 16. Installation Rod    |
| 5. Stirring Blade        | 11. Extrusion Head              | 17. Mode Button         |
| 6. Mixing Bowl           | 12. Handle                      |                         |

## CONTROL PANEL

- 1. Slushie:** Use slushie mode to make icy treats and more.
- 2. Soft Ice Cream:** Use for ice cream, frozen custards, frozen yogurts, sherbet and more.
- 3. Spiked Slushies:** Use spiked slushie mode to make delicious icy drinks with alcohol.
- 4. Sorbet:** Make fresh fruit sorbets for healthier alternatives.
- 5. Milkshake:** Make soft or thick milkshakes with milkshake mode.
- 6. Extrude/Clean:** Use extrude mode to clear the mixing bowl of ingredients when ready. Once done add warm water and soap to previously extruded mixing bowl for a quick clean.



### Control Dial:

Turn the control dial to cycle between textures on specified modes.



Press the control dial to start the mode.

Press and hold the control dial to stop a mode.

### Mode Button:

Use the mode button to cycle between the 6 modes.



**Tip:** Once unit is in COOL, press mode button to begin extrude mode. Press again to go back to COOL mode.

# ASSEMBLY INSTRUCTIONS

**NOTICE:** Keep unit upright for at least 2 hours before first use.

1. Ensure all parts are fully cleaned and the Ice Cream & Frozen Drink Maker is level on a flat, solid surface.

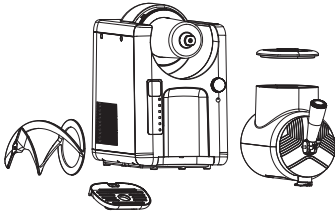

2. Insert the two-part removable drip tray in front of the motor base. Insert the drip tray from the wider side and slide under the main body.

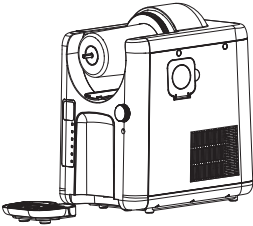

3. Install the stirring blade on the cooling rod. By aligning the square end of the cooling rod with the opening of the stirring blade. Make sure the bottom of the stirring blade is affixed to the cooling rod.

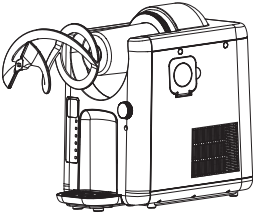

4. Attach the removable decorative cover onto the end of the mixing bowl and turn to the right to lock in place.

5. Insert the mixing bowl onto the main body with the decorative cover facing outward. Once in the correct position turn the mixing bowl clockwise to lock into place. Please reference the icons on the main body of the unit for further reference.

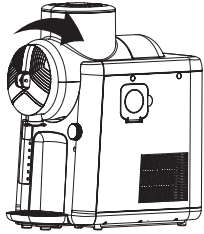

6. Put the removable extrude head into the extrude head slot and install the latch sleeve to tighten it. This part must be in place to operate. Installation rod can be used here to insert properly. See insertion directions below.

## REMOVABLE EXTRUDE HEAD & HANDLE INSTALLATION

1. Insert extrusion head into the extrude head slot right side up (as shown below). Use the installation rod to push the extrusion head into the correct place. This will allow for the handle to be inserted.

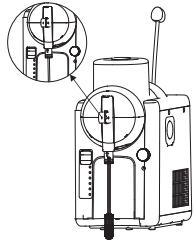

2. Once the extrusion head is in place, insert the handle into the opening of the extrusion head slot. Make sure the handle is facing upward.

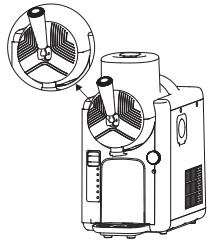

3. Hold this handle in place and thread the handle fixing pin through the hole on the mixing bowl and the hole on the handle. Make sure that the pin latch is in the correct position and place all the way through. Lock the extrusion pin in the up position to continue.
4. To disassemble for cleaning remove the pin and handle and thread the installation rod through the top of the extrude head slot to slide out the removable extrude head.
5. The Ice Cream & Frozen Drink Maker will begin to make your frozen treat. Time will vary depending on the mode selected, temperature of the mix, and amount of content in the mixing bowl.
6. Once the Ice Cream & Frozen Drink Maker determines when the mixture is ready the unit will beep and COOL will display on the screen.

## OPERATION

1. Plug the Ice Cream & Frozen Drink Maker into an outlet. Once this is done the screen will illuminate. If a texture or new mode is not selected in 1 minute the unit will go into standby mode.

2. To select a mode press the Mode Button below the dial until you select your desired mode. The control panel indicator will illuminate on the current mode selected.
3. Once the correct mode is chosen use the control dial to select the desired texture of your frozen treat. Each mode has its own texture level. For reference, Level 1 is thinner and softer and higher levels are more firm or thick. Press the control dial to begin the mixing process.

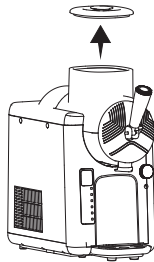

4. **PLEASE NOTE:** Always make sure handle is in up position before adding Ingredients into the mixing bowl. After desired texture is selected and mixing has begun, open the mixing bowl cover and add your ingredients into the mixing bowl.

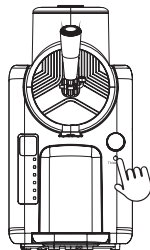

7. You can extrude your frozen treats while in COOL mode by pulling the handle down as the stirring blade will continue to spin. If you want to extrude more quickly, simply press the mode button and the program will change to extrude/clean. After 1 minute this will return to the COOL mode, or you can press the mode button again to return to the previous mode.

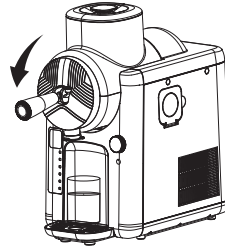

8. If you notice the mixture is not to your desired texture or firmness in cool mode increase the texture level by turning the control dial to a higher setting. A texture cannot be decreased, ONLY increased once in COOL mode. After higher setting is selected press the control dial to confirm.
9. If you want to stop the cooling/mixing process at any time, hold down the control dial for 3 seconds. This will cancel the selected mode and texture selected.

## EXTRUDE/CLEAN MODE

In this mode, the stirring blade rotates at a high speed, without cooling, to extrude or clean all contents from the unit.

### EXTRUDE

1. Select Extrude/Clean mode by pressing the mode button. Confirm mode by pressing the control dial.
2. The stirring blade will begin to spin. Put a large bowl or storage container under the removable extrusion head. Once ready pull the handle down.

### CLEAN

1. Once all of the ingredients are extruded from the mixing bowl. Put the handle into the up position, add warm water and a small amount of soap. Fill up to the bowl's max fill line.

2. The stirring blades will continue to rotate to clean the mixing bowl, cooling rod and stirring blade.
3. The Extrude/Clean mode will work for a total of 5 minutes. Let the soapy water stir for approximately one minute. Add a large bowl or pitcher under the Ice Cream & Frozen Drink Maker and pull the handle down to extrude the contents of the mixing bowl. We recommend repeating this 1 or 2 times to completely clean the unit. Please reference cleaning & maintenance instructions on page 11 for more details.
4. Press and hold the control dial to exit this mode or let the 5 minutes elapse.

**TIP:** Adding warm water and soap more than once will clean the inner parts more.

## PREP-FREE DRINKS

### 1. Pick a Prep-Free bottled or canned beverage.

See options in below section for Slushies, Frozen cocktails and Frozen juices.

**2-3 SERVINGS:** Add 2 1/2 cups      **4-6 SERVINGS:** Add 5 cups

### 2. Chill ingredients before adding.

Chilling your ingredients will result in less icy and smoother texture overall.

### 3. Select Spiked Slushie or Slushie Modes

Adjust the temperature for your preferred texture.

### 4. Serve & Enjoy

## EASY SLUSHIES

- Soda (root beer, cola, ginger ale, orange, grape, cream, or other flavored soda)
- Sweetened Iced Tea
- Lemonade
- Sports Drinks
- Kombucha
- Limeade
- Fruit Punch
- Energy Drinks

## FROZEN COCKTAILS

### Bottled or Canned:

- Sour Beers
- Wine (white or rosé)
- Hard Lemonade
- Hard Seltzers
- Hard Kombucha
- Hard Cider
- Hard Tea
- Premixed Margaritas

### Pre-made Cocktails:

- Old Fashioned
- Cosmopolitan
- Rum Punch

## JUICE SLUSHIES

- Fruit Punch
- Pineapple Juice
- Orange Juice
- Apple Juice/Apple Cider
- Bottled Pre-Made Smoothies
- Cherry Juice
- Cranberry Juice
- Grape Juice
- Mango Juice
- Tropical Juice
- Watermelon Juice

**8 NOTE:** Please refer to page 9 for Sugar & Alcohol requirements.

# HARD ALCOHOL/ SPIRIT GUIDELINES

Creating a delicious frozen cocktail is easy with your Ice Cream/Frozen Drink maker!

Just follow these simple guidelines:

**Option 1:** Using a canned or bottled beverage (Beer, Wine, Seltzer etc.)

Your drink must be between 2.8% and 16% alcohol for the best results.

Lower alcohol (closer to 2.8%)? It will freeze faster and have a more icy texture.

Higher alcohol (closer to 16%)? It will freeze more slowly and have a slushier texture.

Too much alcohol? If it's over 16%, it won't freeze properly and have a very thin texture.

**Option 2:** Mixing Hard Spirits Into Your Drink.

If adding a hard spirit (vodka, tequila, rum, etc.) to any liquids to create your own spiked slushie, follow the chart below to keep the balance right:

Total Recipe Size	Maximum Alcohol Amount
3 Cups (24 oz)	½ Cup ( 4 oz)
4½ Cups (36 oz)	¾ Cup (6 oz)
6 Cups (48 oz)	1 Cup (8 oz)

## Important:

### Adjusting Your Slushie's Texture

If your drink isn't freezing as expected:

- Too icy? Increasing the alcohol content slightly, adding more sugar or lowering the texture setting can all help.
- Too soft? Reducing the alcohol content slightly, reducing the sugar or increasing the texture setting, can all help.
- Still not right? Adjust the texture setting on your machine and tweak the alcohol/sugar balance until you get the perfect slushie.

# SUGAR CONTENT

The entire recipe must contain at least 4% sugar. Refer to drink/liquid nutrition label to ensure sugar content meets the recommended minimums below:

Listed Serving Size	Minimum Total Sugar Amount
8 oz (240 ml)	8 g
12 oz (355 ml)	11 g
20 oz (591 ml)	18 g

If a drink does not meet minimum requirement of total sugar: Add 1–2 tablespoons of flavored syrup, juice, sugar, date sugar, coconut sugar, maple syrup, agave, simple syrup, or honey per serving. Combine additional sugar with the base prior to pouring into unit.

If there is not enough sugar in the recipe added to the machine the display will illuminate "EEE" and the Ice Cream/Frozen Drink Maker will Beep. To avoid this, always have a minimum of 4% sugar in the mixture. To clear this, you must either add more liquid or allow the mixture to thaw for 30 minutes before restarting.

**PLEASE NOTE:** Sugar can be added to the ingredients before EEE is displayed on screen.

## QUICK TIPS

Minimum input = 3 cups (24 oz/710 ml)

Maximum input = 6 cups (48oz/1.4L)

**PLEASE NOTE:** the maximum input will expand due to freezing. Final output is up to 64oz. This will depend on the ingredients being used.

For the best dispensing experience, fill the unit to the max-fill line (48 oz)

**Always be sure to have handle in the UP position when filling with ingredients. This will prevent ingredients from extruding from the extrusion head.**

- Keep the Ice Cream and Frozen Drink Maker upright for at least 2 hours before first use.
- Mixture can be extruded at any time during the cooling/ mixing process. It is not necessary to go into the Extrude/ Clean Mode to dispense contents from this machine. As long as the stirring blade is moving contents can be dispensed.
- The Ice cream & Frozen Drink Maker will automatically go into cool mode for 2 hours after the selected texture setting has been reached. The Ice Cream & Frozen Drink Maker will automatically shut off after cool mode has finished.
- We recommend that any Ice Cream, Frozen Yogurt or Sorbet that you do not eat immediately be stored in a sealed container in your freezer.
- Please note that ingredients always taste sweeter before they are frozen, do not worry if it seems too sweet before adding it to the Ice cream and Frozen Drink Maker.
- When using the Spiked Slushie mode, all pre-made mixes and recipes must contain between 2.8% and 16% alcohol.
- For best results, chill liquid(s) or blended ingredients before adding to the unit.
- For the best dispensing experience, fill the unit to the max-fill line
- **DO NOT OVERFILL.**

### IMPORTANT:

ONLY add mix-ins after you have extruded into your own bowl or container.

### DO NOT add mix-ins to the Mixing Bowl

For best results when using soda or carbonated beverages vigorously stir or shake the soda first to reduce the level of carbonation.



DO NOT add hot ingredients, ice, or solid ingredients like fruit, ice cream, or frozen fruit.



The entire recipe must contain at least 4% sugar. If the sugar content is below 4%, you can add syrup or sugar.



Use the control dial to find your ideal texture.



For best and faster results, chill liquid(s) before adding to the unit.



For an extra icy drink, chill your glass before dispensing your creations.



For best results when using soda or carbonated beverages vigorously stir or shake the soda first to reduce the level of carbonation.

## MODE REFERENCE TABLE

Preset	Default	Texture Range and Default Texture
Slushie	L:4	Levels 1-7 If you like softer slushies choose a lower level. If you are looking for more texture and ice use a higher level. For lower sugar drinks, it is recommended to choose level 1 or 2.
Soft Ice Cream	L:4	Levels 1-6 If you like softer ice cream choose a lower level. If you are looking for firmer ice cream use a higher level.
Spiked Slushie	L:4	Levels 1-7 If you like softer slushies choose a lower level. If you are looking for more texture and ice use a higher level. For lower sugar drinks, it is recommended to choose level 1 or 2.
Sorbet	L:4	Levels 1-6 If you like softer sorbet choose a lower level. If you are looking for firmer sorbet use a higher level.
Milkshake	L:3	Levels 1-4 If you like softer milkshake choose a lower level. If you are looking for thicker milkshake use a higher level.
Extrude/ Clean	/	5 min

# CLEANING & MAINTENANCE

**IMPORTANT:** For easier cleaning of internal parts always use extrude/ clean mode before removing mixing bowl. The Extrude/Clean mode will work for a total of 5 minutes. Let the soapy water stir for approximately one minute. Add a large bowl or pitcher under the Ice Cream & Frozen Drink Maker and pull the handle down to extrude the contents of the mixing bowl. We recommend repeating this 1 or 2 times to completely clean the unit. The Stirring blade, mixing bowl, two-part removable drip tray, extrusion head, cleaning brush and removable decorative cover are top rack dishwasher safe.

## DISASSEMBLY FOR CLEANING

1. Pull out the pin, remove the handle, and rotate counterclockwise to remove the decorative cover.

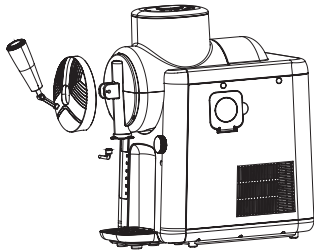

2. Use the installation rod to push out the removable extrusion head for cleaning, and then use the cleaning brush to clean the extrude head slot.

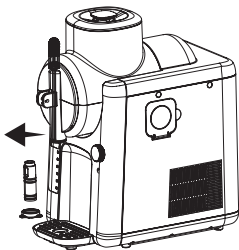

3. Rotate the mixing bowl counterclockwise, then gently remove the mixing bowl from the main unit and set it aside.

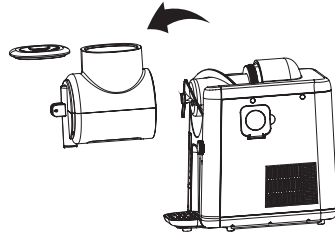

4. Remove the stirring blade from the cooling rod and wipe the remaining liquid on and around the cooling rod with a dry dishcloth.

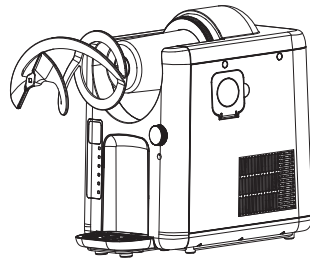

5. Slide the two-part removable drip tray out of the main body and clean the parts with wet soapy water. Dry before using again.

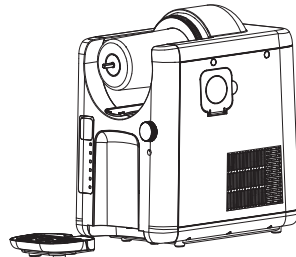

# TROUBLESHOOTING

Issue	Cause	Solution
After the frozen treat is made, it is difficult to remove the bowl.	There may have been water in the mixing bowl before the unit was started creating ice behind the bowl.	Wait 10 to 15 minutes for the unit to thaw before trying again.
Your frozen treat is too grainy	There is too much water in your recipe.	Increase, milk, cream or sugar ratio.
Machine Displays "EEE" message	Incorrect ingredient amount or sugar ratio	Increase ingredients to a minimum of 24oz or make sure that there is enough sugar in your mixture.
The machine stops working	Poor exhaust and high internal temperature	The product is too close to the wall, resulting in poor air circulation and high temperature. The product vent should be at least 20cm away from the wall. To solve, wait 10-15mins & try again. If issue persists please contact customer service team.
The recipe is not freezing on spiked slushie mode	High Alcohol or sugar content.	Make sure that the alcohol percentage is not over 16% a higher alcohol content will make the recipe difficult to freeze.
The recipe is not freezing on Slushie, Soft Ice Cream, and Milkshake mode.	High sugar content or overfilled mixing bowl	If you are using too high of a sugar content dispense some of the liquid and replace with water or liquid without sugar. If there is too much liquid, the contents will take much longer to freeze and will risk overflowing due to expansion. If issues persist, contact customer service.

# LIMITED WARRANTY

GreenPan Electrics are covered by a limited warranty against defects in materials and workmanship, beginning on the date you receive the product and lasting for two years. If your GreenPan Electrics product has a defect covered by the limited warranty during the warranty period, The Cookware Company (USA), LLC will either repair or replace the product. Further information on the warranty claim process, exclusions from warranty coverage, and other terms can be found in the complete limited warranty for this product, available online at [greenpan.us/warranty](http://greenpan.us/warranty)."

# TERMS OF SALE; ARBITRATION

The terms on which The Cookware Company (USA), LLC sells GreenPan Electrics are available online at [greenpan.us/pages/terms-of-sale](http://greenpan.us/pages/terms-of-sale) (the "Terms"). The Terms contain very important information regarding your rights and obligations, as well as conditions, limitations, and exclusions that may apply to you. Please read them carefully.

In particular, the Terms provide that, by your purchase of this product, you and The Cookware Company (USA), LLC are agreeing to give up any rights to litigate in a court or before a jury, or to participate in a class action or representative action with respect to a claim. Other rights that you would have if you went to court may also be unavailable or limited in arbitration. Any claim, dispute, or controversy between you and The Cookware Company (USA), LLC arising from or relating in any way to your purchase of products or services will be resolved exclusively and finally by binding arbitration.

The arbitration will be administered by the American Arbitration Association ("AAA") in accordance with the Consumer Arbitration Rules (the "AAA Rules") then in effect, except as modified hereby. (The AAA Rules are available at [adr.org](http://adr.org) or by calling the AAA at 1-800-778-7879.) The Federal Arbitration Act will govern the interpretation and enforcement of this arbitration and waiver provision.

The Cookware Company (USA), LLC will be responsible for the AAA filing fee of any such proceeding. Other than your right to pursue a claim in small claims court, as described in the Terms, the arbitrator will have exclusive authority to resolve any dispute relating to arbitrability and/or enforceability of this arbitration provision, including any unconscionability challenge or any other challenge that the arbitration provision or these Terms are void, voidable or otherwise invalid. The arbitrator will be empowered to grant whatever relief would be available in court under law or in equity. Any award of the arbitrator(s) will be final and binding on each of the parties and may be entered as a judgment in any court of competent jurisdiction. Attorney fee shifting in this case is governed by the Terms. You agree to an arbitration on an individual basis. In any dispute, NEITHER YOU NOR THE COOKWARE COMPANY (USA), LLC WILL BE ENTITLED TO JOIN OR CONSOLIDATE CLAIMS BY OR AGAINST OTHER CUSTOMERS IN COURT OR IN ARBITRATION OR OTHERWISE PARTICIPATE IN ANY CLAIM AS A CLASS REPRESENTATIVE, CLASS MEMBER OR IN A PRIVATE ATTORNEY GENERAL CAPACITY. The arbitral tribunal may not consolidate more than one person's claims and may not otherwise preside over any form of a representative or class proceeding. The arbitral tribunal has no power to consider the enforceability of this class arbitration waiver and any challenge to the class arbitration waiver may only be raised in a court of competent jurisdiction.

If any provision of the arbitration agreement described herein and in the Terms is found unenforceable, the unenforceable provision will be severed and the remaining arbitration terms will be enforced.







1400030980