

TOMAHAWK

TFS10H
10" EARLY ENTRY CONCRETE SAW

Operation Manual

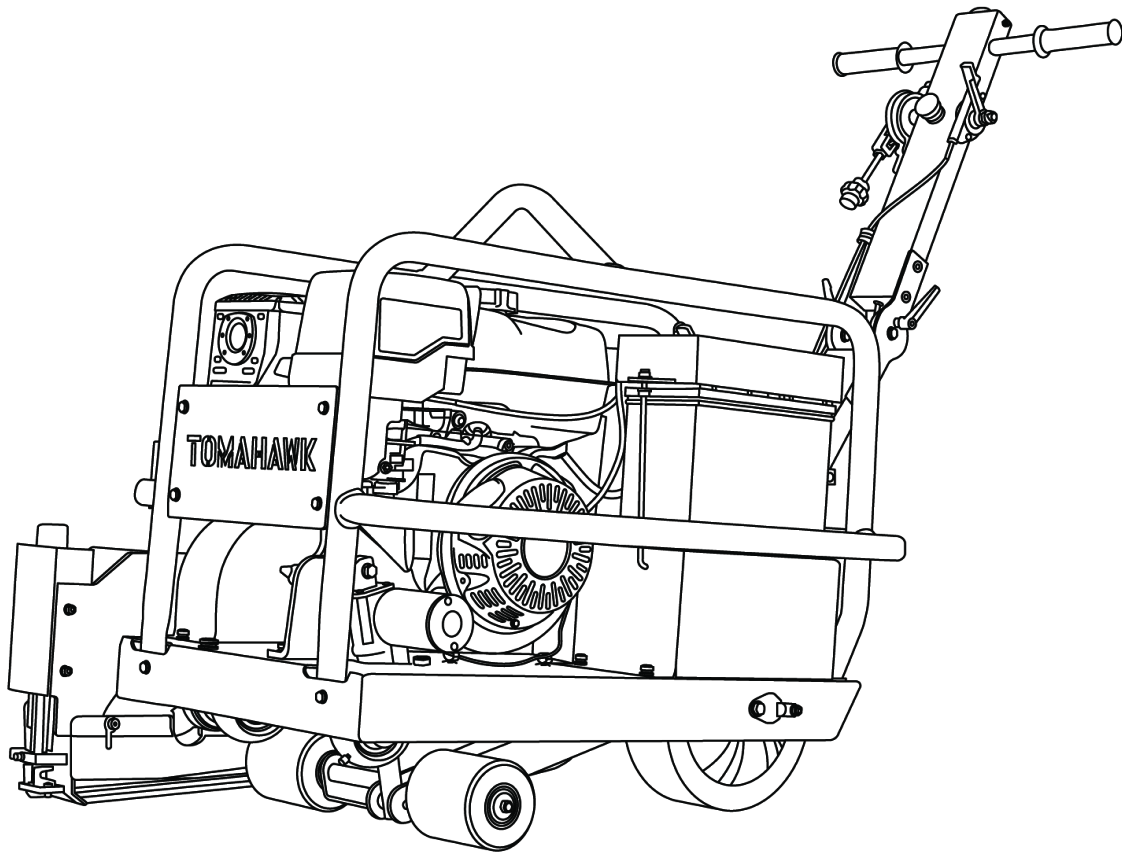

SCAN FOR ASSEMBLY GUIDE



HOW TO VIDEOS, MANUALS,
FINISHING GUIDES, & MORE

HONDA
ENGINES



CALIFORNIA
AIR RESOURCES BOARD



TABLE OF CONTENTS

1. SAFETY INFORMATION	4
- Laws Pertaining to Spark Arresters	5
- Operating Safety	5
- Safety while using Combustion Engines	6
- Service Safety	6
2. TECHNICAL DATA	7
- Design and Features	7
- Honda Engine	7
- Machine Data	8
3. STARTING AND STOPPING	8
- Recommended Fuel	8
- Low Oil Sensor	8
- Before Starting	9
- Starting	9
- Cutting	10
4. FUEL HANDLING	11
5. OPERATION	13
6. MAINTENANCE	18
- Replacement Parts	21
- Maintenance Schedule	22
7. TROUBLESHOOTING	23
8. PARTS MANUAL	25
9. CATALOG	42
10. COUPON	43

Register Your Equipment

Thank you for purchasing TOMAHAWK® equipment! Your product is covered by the TOMAHAWK® Warranty policy, but in order to activate your warranty, we need you to register your product. In addition to activating your equipment warranty, product registration will grant you access to important product updates, streamlined customer service and more.

INCLUDED WITH YOUR REGISTRATION

- ✓ Equipment Warranty Activation
- ✓ Product Updates
- ✓ Streamlined Customer Service
- ✓ Exclusive Discounts and Sales

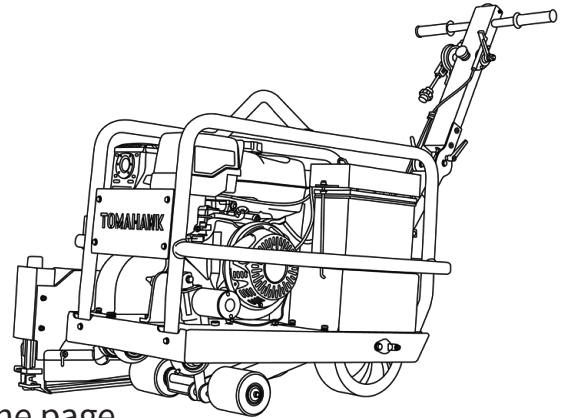

STEPS TO REGISTER YOUR EQUIPMENT

1. Visit www.tomahawk-power.com
2. Choose “Product Registration” at the bottom of the page
3. Enter your equipment’s serial number to get started
4. Provide all required information
5. Submit Registration

Equipment Resources

TOMAHAWK® Customer Service doesn’t stop at checkout. We understand to keep a job-site running smoothly - the proper equipment, spare parts, instruction manuals, and more are needed at the drop of a hat. Visit www.tomahawk-power.com to gain access to the incredible resources below.

How To Video Library

More of a visual person? Visit our Video Library for equipment assembly instructions, troubleshooting tips, and more!

Found in the TOMAHAWK® Resource Center.

Manual and Assembly Guide Library

Visit our Manual Library if you are looking for a lost operations manual or a particular spare part?

Found on the TOMAHAWK® Manuals Page.

Service Requests

In need of a quick fix or a service center referral? Submit a Service Request and a TOMAHAWK® Technician will respond shortly to get you the help you need.

Choose “Service Request” at the bottom of www.tomahawk-power.com.



This manual provides information and procedures to safely operate and maintain this equipment. For your own safety and protection from injury, carefully read, understand and observe the safety instructions described in this manual.

Keep this manual or a copy of it with the equipment. If you lose this manual or need an additional copy, please contact TOMAHAWK® or visit www.tomahawk-power.com This equipment is built with user safety in mind; however, it can present hazards if improperly operated and serviced. Follow operating instructions carefully. If you have questions about operating or servicing this equipment, contact TOMAHAWK®.

The information contained in this manual is based on equipment's production at the time of publication. TOMAHAWK® reserves the right to change any portion of this information without notice.

No part of this publication may be reproduced in any form or by any means, electronic or mechanical, including photocopying, without express written permission from TOMAHAWK®.

Any type of reproduction or distribution not authorized by TOMAHAWK® represents an infringement of valid copyrights and will be prosecuted. We expressly reserve the right to make technical modifications, even without due notice, which aim at improving our machines or their safety standards.

1. SAFETY INFORMATION

This manual contains DANGER, WARNING, CAUTION, and NOTE callouts which must be followed to reduce the possibility of personal injury, damage to the equipment, or improper service.



This is the safety alert symbol. It is used to alert you to potential personal injury hazards. Obey all safety messages that follow this symbol to avoid possible injury or death.



DANGER indicates an imminently hazardous situation which, if not avoided, will result in death or serious injury.



WARNING indicates a potentially hazardous situation which, if not avoided, could result in death or serious injury.



CAUTION indicates a potentially hazardous situation which, if not avoided, may result in minor or moderate injury.

CAUTION: Used without the safety alert symbol, **CAUTION** indicates a potentially hazardous situation which, if not avoided, may result in property damage.

1.1 Laws Pertaining to Spark Arresters

Notice: State Health Safety Codes and Public Resources Codes specify that in certain locations spark arresters be used on internal combustion engines that use hydrocarbon fuels. A spark arrester is a device designed to prevent accidental discharge of sparks or flames from the engine exhaust. Spark arresters are qualified and rated by the United States Forest Service for this purpose.

In order to comply with local laws regarding spark arresters, consult the engine distributor or the local Health and Safety Administrator.

1.2 Operating Safety



Familiarity and proper training are required for the safe operation of equipment! Equipment operated improperly or by untrained personnel can be dangerous! Read the operating instructions contained in both this manual and the engine manual and familiarize yourself with the location and proper use of all controls. Inexperienced operators should receive instruction from someone familiar with the equipment before being allowed to operate the machine.

1.2.1 NEVER allow anyone to operate this equipment without proper training. People operating this equipment must be familiar with the risks and hazards associated with it.

1.2.2 NEVER touch the engine or muffler while the engine is on or immediately after it has been turned off. These areas get hot and may cause burns.

1.2.3 NEVER use accessories or attachments that are not recommended by TOMAHAWK®. Damage to equipment and injury to the user may result.

1.2.4 NEVER leave machine running unattended.

1.2.5 ALWAYS be sure operator is familiar with proper safety precautions and operation techniques before using machine.

1.2.6 ALWAYS wear ANSI Z87.1-approved safety goggles or safety glasses with side shields, or when needed, a face shield. Use a dust mask in dusty work conditions. Also use non-skid safety shoes, hardhat, gloves, dust collection systems, and hearing protection when appropriate. This applies to all persons in the work area.

1.2.7 ALWAYS close fuel valve on engines equipped with one when machine is not being operated.

1.2.8 ALWAYS store equipment properly when it is not being used. Equipment should be stored in a clean, dry location out of the reach of children.

1.2.9 ALWAYS operate machine with all safety devices and guards in place and in working order. **DO NOT** modify or remove safety devices. **DO NOT** operate machine if any safety devices or guards are missing or inoperative.

1.2.10 ALWAYS read, understand, and follow procedures in Operator's Manual before attempting to operate equipment.

1.3 Safety while using Combustion Engines



Internal combustion engines present special hazards during operation and fueling! Read and follow warning instructions in engine owner's manual and safety guidelines below. Failure to follow warnings and DANGER safety guidelines could result in severe injury or death.

1.3.1 DO NOT run machine indoors or in an enclosed area such as a deep trenches unless there is adequate ventilation, through such items as exhaust fans or hoses are provided. Gasoline exhaust from the engine contains poisonous carbon monoxide gas; exposure to carbon monoxide can cause loss of consciousness and may lead to death.

1.3.2 DO NOT smoke while operating machine.

1.3.3 DO NOT smoke when refueling engine.

1.3.4 DO NOT refuel hot or running engine.

1.3.5 DO NOT refuel engine near open flame.

1.3.6 DO NOT spill fuel when refueling engine.

1.3.7 DO NOT run engine near open flames.

1.3.8 ALWAYS refill fuel tank in well-ventilated area.

1.3.9 ALWAYS replace fuel tank cap after refueling.

1.3.10 ALWAYS check fuel lines and fuel tank for leaks and cracks before starting engine.

1.3.11 DO NOT run machine if fuel leaks are present or fuel lines are loose.

1.4 Service Safety



Poorly maintained equipment can become a safety hazard! In order for the equipment to operate safely and properly over a long period of time, periodic maintenance and occasional repairs are necessary.

1.4.1 DO NOT attempt to clean or service machine while it is running. Rotating parts can cause severe injury.

1.4.2 DO NOT crank a flooded engine with the spark plug removed on gasoline-powered engines. Fuel trapped in the cylinder will squirt out the spark plug opening.

1.4.3 DO NOT test for spark on gasoline-powered engines, if engine is flooded or the smell of gasoline is present. A stray spark could ignite fumes.

1.4.4 DO NOT use gasoline or other types of fuels or flammable solvents to clean parts, especially in enclosed areas. Fumes from fuels and solvents can become explosive.

1.4.5 ALWAYS keep area around muffler free of debris such as leaves, paper, cartons, etc. A hot muffler could ignite them, starting a fire.

1.4.6 ALWAYS replace worn or damaged components with spare parts designed and recommended by TOMAHAWK®.

1.4.7 ALWAYS disconnect spark plug on machines equipped with gasoline engines, before servicing, to avoid accidental start-up.

1.4.8 ALWAYS keep machine clean and labels legible. Replace all missing and hard-to-read labels. Labels provide important operating instructions and warn of dangers and hazards.

1.4.9 ALWAYS check for damaged parts before each use. Carefully check that the screed will operate properly and perform its intended function. Replace damaged or worn parts immediately. Never operate the screed with a damaged part.

1.4.10 ALWAYS inspect the screed prior to placing in storage and before re-use. Store the screed in a dry, secure place out of the reach of children when not in use.

1.4.11 ALWAYS use only accessories that are recommended by the manufacturer for use with the screed. Accessories that may be suitable for one Screed may create a risk of injury when used with the screed equipment.

1.4.12 ALWAYS keep boards clean when not in use and guards in place and in working order.

2. TECHNICAL DATA

2.1 Design and Features

Features such as high performance, reliability, innovative technology, advanced technical solutions and environmental considerations distinguish TOMAHAWK® products. Safe operation of this product requires the operator to read this manual carefully. Ask your dealer or TOMAHAWK® if you need more information. Some of the unique features of your product are described below.

2.2 Low Noise and Low Dust Blade Block Enclosure

Low noise, low dust blade block, and skid plate technology in conjunction with TOMAHAWK® blades allows for ultra early entry sawing the same day while minimizing chipping and spalling.

2.3 Honda Engine

Honda's GX390 engine is legendary for superior reliability and performance. And there's no doubt about it. Low noise levels, low vibration, and low emissions – without sacrificing power output or performance.

2.4 Machine Data

ENGINE DATA	
Engine Brand	Honda
Engine Model	GX270
Engine Type	UT2X
Displacement	270
Net Power Output*	5.8/9.0
Net Torque	15.3/2500
Starting System	Electric
Oil Capacity	1.1
Fuel Tank Capacity	5.3
SAW DATA	
Hydraulic Motor	Danfoss BDU-10S-222
Maximum Blade Diameter, in. (mm)	10(254)
Maximum Depth Of Cut, in. (mm)	1 1/2 (38 mm)
Average Bladeshaft, RPM	3600 @ 3600 RPM
Arbor	Trangular
Bladeshaft Diameter, in. (mm)	35mm
Air Filter	Cyclonic
Axle Front/Rear, in. (mm)	370mm
Wheels Front, in. (mm)	100mm
Wheels Rear, in. (mm)	250mm
Handlebar Adjustment	Manual
Blade Guard Type	Fully Closed
Number Of Belts	840La
Blade Depth Control	Electric Adjustment
Maximum Weight Uncrated, lbs (kg)	360 (163)

3. STARTING AND STOPPING

3.1 Recommended Fuel

The engine requires regular grade unleaded gasoline, 91 Octane or higher. Use only fresh, clean gasoline. Gasoline containing water or dirt will damage the fuel system. Consult engine owner's manual for complete fuel specifications.

3.2 Low Oil Sensor

The low oil sensor is located inside the oil reservoir. Its primary job is to measure the amount of oil inside the engine prior to the engine being started. If the oil is low, the sensor will trigger and it will not be possible to start the engine.

NOTE: The low oil sensor may trigger if the saw is in the upright position. The upright angle of the machine can cause the oil to fall below the sensor and trigger it. Before starting the engine, check that the oil level is raised above the sensor and/or the machine is lowered to allow the low oil sensor to get an accurate oil level reading.

3.3 Before Starting



Please read the operator's manual carefully and make sure you understand the instructions before using the machine.

Wear personal protective equipment. Refer to the instructions under the "Personal Protective Equipment" heading.

Make sure no unauthorised persons are in the working area, otherwise there is a risk of serious personal injury.

Check that the guards are mounted correctly and do not show any signs of damage. See instructions in the section "Machine's Safety Equipment" and "Assembly and Settings".

- Make sure the engine is filled with SAE10W30 4 Stroke Oil and 91 Octane Fuel. If the oil and fuel levels are too low, the low oil sensor will not allow the engine to start
- Check that the handle is in a full upright position and pinned.
- Check that the front guide is rotated to the FORWARD position.

3.4 Starting

Start the Engine

- Move the fuel valve lever to the ON position (A)
- Raise the blade by pulling up on the guide lever (D).
- To start a cold engine, move the choke lever (B) or choke rod (applicable types) to the CLOSED position.
- Move the throttle to the neutral position (E).
- Turn the key (C) to the START position, and hold it there until the engine starts.

The closed choke position enriches the fuel mixture for starting a cold engine. The open choke position provides the correct fuel mixture for operation after the engine starts and for restarting a warm engine.

- After the engine starts, slowly open the choke (B).
- Allow the engine to warm for a few minutes.

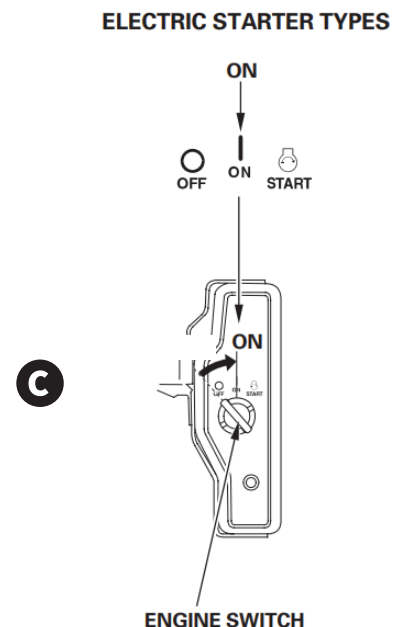
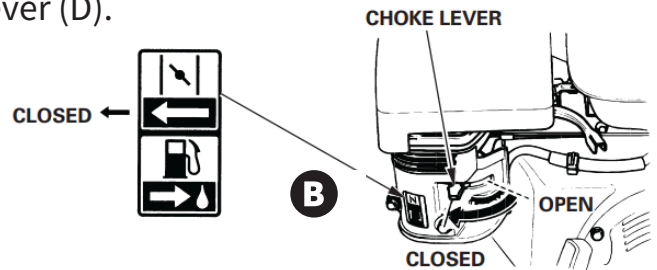
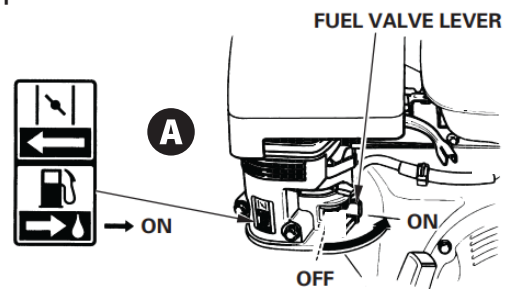

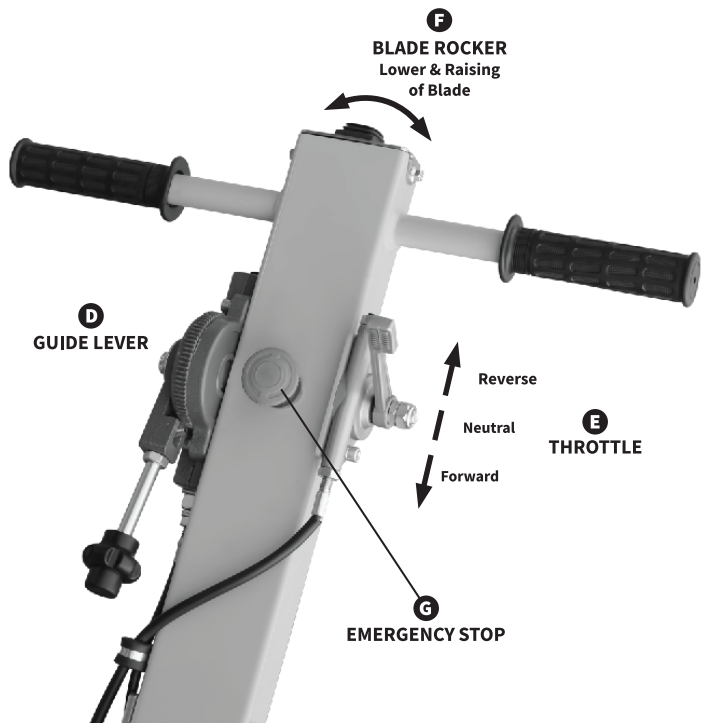

3.5 Cutting

- Move the throttle lever (E) to full OPEN position for maximum engine speed.
- Line up the saw with the cut line pushing down the guide lever (D).
- To lower the blade, push down the blade rocker button (F) on the saw handle.
- To move the saw forward, move the throttle (E) slowly down. (This saw is self-propelled and does not require and pushing.)
- To move in reverse, move the throttle (E) slowly past Neutral up towards you.
- When approaching a wall, raise the front guide (D) and use the triangle guide behind the blade block to cut the last few feet.
- **DO NOT** hit the blade block assembly against any object as this may cause damage.

4. FUEL HANDLING



Running an engine in a confined or badly ventilated area can result in death due to asphyxiation or carbon monoxide poisoning. Use fans to ensure proper air circulation when working in trenches or ditches deeper than one meter.

Fuel and fumes are highly flammable and can cause serious injury when inhaled or allowed to come in contact with the skin. For this reason, observe caution when handling fuel and make sure there is adequate ventilation.

The exhaust fumes from the engine are hot and may contain sparks which can start a fire. Never start the machine indoors or near combustible material!

Do not smoke and do not place any hot objects in the vicinity of fuel.

4.1 Fuel

4.1.1 Use unleaded gasoline with an octane rating of 91 or higher.

4.1.2 Unleaded gasoline with more than 10% ethanol should not be used. It may cause starting and/or performance problems. It may also damage metal, rubber, and plastic parts of the fuel system, as well as posing a fire hazard.

4.1.3 DO NOT use gasoline containing methanol.

4.1.4 DO NOT use fuel that is older than 30 days. Old fuel can cause running problems as well as fuel system damage

4.2 Fueling



Always stop the engine and allow it to cool for a few minutes before refueling. Refuel the engine in a well ventilated area. Never fuel the engine indoors.

When refuelling, open the fuel cap slowly so that any excess pressure is released gently. Never overfill the fuel tank.

Clean the area around the fuel cap.

Tighten the fuel cap carefully after refuelling. Check for fuel leaks.

Failure to follow these guidelines may lead to a fire.

4.2.1 When refueling, remove the equipment from the vehicle and refuel it on the ground. If this is not possible, refuel the equipment with a portable container, rather than from a petrol dispenser nozzle.

4.2.2 When refueling, remove the equipment from the vehicle and refuel it on the ground. If this is not possible, refuel the equipment with a portable container, rather than from a petrol dispenser nozzle. Use only approved gasoline containers.

4.2.3 NEVER refuel inside a vehicle. Always place the container on the ground - away from your vehicle when filling.

4.2.4 Keep the nozzle in contact with the rim of the fuel tank or container opening at all times until fuelling is complete. DO NOT use a nozzle lock-open device.

4.2.5 NEVER start the machine if:

- You have spilled fuel or engine oil on the machine.
- Wipe off the spill and allow the remaining fuel to evaporate before resuming.
- You have spilled fuel on yourself or your clothes.
- Change your clothes.
- Wash any part of your body that has come in contact with fuel.
- Use soap and water to clean.
- The machine is leaking fuel.
- Check regularly for leaks coming from the fuel cap and fuel lines.

4.3 Disposal

Dispose of used engine oil after use.

4.3.1 Used engine oil, antifreeze, etc. is a health hazard and must NOT be disposed of on the ground or in nature. It should always be disposed of at a workshop or at an appropriate disposal location.

4.4 Transportation

Properly store and transport the machine and its unused fuel to eliminate risk of any leakage or fumes coming into contact with sparks or open flames.

4.4.1 Store away from electrical machinery, electric motors, electrical relays/switches or boilers.

4.4.2 When storing and transporting fuel, always use approved containers intended for this purpose.

4.5 Long Term Storage

Properly store and transport the machine and its unused fuel to eliminate risk of any leakage or fumes coming into contact with sparks or open flames. Contact your local petrol station to find out where to dispose of used/excess fuel.

5. OPERATION

5.1 General

DO NOT use the equipment unless you are able to call for help - in the event an accident occurs.

5.2 Personal Protective Equipment (PPE)

Approved personal protective equipment must be used when operating the machine. Personal protective equipment cannot eliminate the risk of injury, but it will reduce the degree of injury if an accident does happen.



The use of products such as cutters, grinders, drills, that sand or form material can generate dust and vapors which may contain hazardous chemicals. Check the nature of the material you intend to process and use an appropriate breathing mask.

Long-term exposure to noise can result in permanent hearing impairment. Always use approved hearing protection. Listen out for warning signals or shouts when you are wearing hearing protection. Always remove your hearing protection as soon as the engine stops.

5.3 ALWAYS wear the following when operating:

- Approved protective helmet
- Hearing protection
- Approved eye protection
- Breathing mask
- Heavy-duty, firm grip gloves
- Tight-fitting, heavy-duty and comfortable clothing that permits full movement
- Boots with steel toe-caps and non-slip sole
- Rubber work gloves to avoid contact with wet concrete, which can cause skin irritation.
- Be careful as clothing, long hair, and jewelry can get caught in moving parts.



Other Protective Equipment

Sparks may appear and start a fire. ALWAYS keep fire safety equipment readily available.

5.4 Operators must have the following equipment:

- Fire extinguisher
- First aid kit



General Safety Precautions

Operators must read all safety warnings and all instructions. Failure to follow the warnings and instructions may result in electric shock, fire, and/or serious injury.

5.5 This section describes basic safety directions for using the machine. This information is never a substitute for professional skills and experience.

- Read the operator's manual carefully and make sure you understand the instructions= before using the Early Entry Green Concrete Saw.
- Keep in mind that it is you, the operator, that is responsible for not exposing people or their property to accidents or hazards.
- All operators shall be trained in the use of the machine. The owner is responsible for ensuring that the operators receive training.
- The machine must be kept clean. Signs and stickers must be fully legible.



WARNING

Unauthorized modifications to the machine and/ or unauthorized accessories may lead to serious injury or death to the user or others.

Under no circumstances may the design of the machine be modified without the permission of the manufacturer, TOMAHAWK®.

DO NOT modify this product or use it if it appears to have been modified by other companies that are not TOMAHAWK®.

Never use a machine that is faulty.

Perform ALL safety checks, maintenance and service instructions described in this manual. Some maintenance and service measures must be carried out by trained and qualified specialists. See instructions under the Maintenance heading.

Always use genuine accessories manufactured or approved by TOMAHAWK®.



WARNING

WARNING! This machine produces an electromagnetic field during operation. This field may, under some circumstances, interfere with active or passive medical implants.

To reduce the risk of serious or fatal injury, we recommend persons with medical implants to consult their physician and the medical implant manufacturer before operating this machine.

5.6 Always Use Common Sense

7.6.1 Always exercise safety and use common sense when operating this machine. If you get into a situation where you feel unsafe, stop and seek expert advice.

5.6.2 Contact your dealer, service agent, an experienced user, or a TOMAHAWK® Customer Service Technician.

5.6.3 Do not attempt any task that you feel unsure of.

5.7 Work Safety

5.7.1 Work Area Safety

- Keep your work area clean and well lit. Cluttered or dark areas invite potential accidents.
- Define and cordon off the risk area. Keep people and animals well away from the operating area.
- People and animals can distract, causing you to lose control of the machine. For this reason, always remain concentrated and focused on the task.
- Do not use the machine in bad weather, such as dense fog, heavy rain, strong wind, intense cold, etc. Working in bad weather is tiring and can lead to dangerous conditions, e.g. slippery surfaces.
- NEVER start to work with the machine before the working area is clear and you have a firm foothold.

5.7.2 Personal Safety

- NEVER use the machine if you are fatigued, while under the influence of alcohol, drugs, medication, or anything that could affect your vision, alertness, coordination or judgement.
- Ensure the switch is in the OFF-position to prevent unintentional starting.
- Check that no tools or other objects have been left lying on the machine.
- NEVER allow anyone else to use the machine without proper training.
- ALWAYS shut off the machine during longer work breaks.
- NEVER work alone. Ensure there is another person close at hand.
- Learn how to use the machine and its controls safely and learn how to stop quickly. Learn and identify the safety decals.
- Do not overreach. Keep proper footing and balance at all times.

5.7.3 Use and Care

- Experience is very important when running the machine. A skilled operator is highly recommended for this machine.
- ALWAYS perform daily maintenance checks before starting the engine. See instructions in the section "Maintenance".
- The machine is intended for use in industrial applications by experienced operators. Only operate the saw from behind the machine with both hands on the handle.
- Use caution when loading, unloading, and when maneuvering the machine on ramps.
- DO NOT use the machine as a vehicle for transporting personnel or equipment.
- NEVER stand on the machine.
- DO NOT overload the machine. This will damage the machine.
- Keep tools sharp and clean in order to enable safer work.
- Keep all parts in good working order and ensure that all fixtures are properly tightened.
- NEVER leave the machine unsupervised with the motor running.

5.7.4 Use and Care Continued

- Make sure the blade does not make contact with the ground or any other surface when maneuvering the saw.
- Avoid getting in direct line with the blade or contacting the blade while it is rotating.

5.8 Basic Working Techniques

5.8.1 Sawing Contraction Joints

As concrete hydrates or cures begin to set, it develops internal stress, which may cause random cracks.

Random cracks cast doubt on the quality and workmanship of the concrete. Contraction joints are cut in concrete to relieve these stresses before they seek their own relief in the form of random crack.

The TOMAHAWK® Early Entry Green Concrete Saw system controls random cracking through the early timing of a saw cut at predetermined locations. This is to create weakened planes in the concrete that subsequently crack at the bottom of the cut to relieve stress.

TOMAHAWK® sawed contraction joints should be a minimum of 1/8th the concrete depth and a minimum of 25 mm (1”) deep.

Contraction joints should be cut as soon as the concrete will support the weight of the saw and the operator without marking or damaging the concrete.

There are many possibilities for joint layout. Joint layout should be provided, the contractor should submit a detailed joint layout for approval prior to cutting.

Several factors affect joint spacing including:

- Concrete thickness.
- Type, amount, and location of reinforcement.
- Shrinkage potential of concrete-cement (type, quantity), aggregate (size, quantity, quality), water to cement ratio, admixtures, concrete temperature.
- Base friction.
- Slab restraints.
- Layout of foundations, racks, pits, equipment pad, trenches, etc.
- Environmental factors: temperature, wind, humidity.
- Methods and quality of concrete curing.

5.8.2 Sawing Contraction Joints Continued

Generally, contraction joint patterns should divide slabs into approximate square panels per the recommended spacing shown.

Concrete thickness, mm(in.)	Maximum spacing, m (ft.)
90 (3.5)	2,4 (8)
100, 114 (4, 4.5)	3,0 (10)
125, 140 (5, 5.5)	3,6 (12)
150 (6) or greater	4,5 (15)

At all intersecting cross cuts, install a joint protector at each joint to prevent joint damage. Install an additional joint protector where the right wheel will cross the joint to prevent concrete damage.

5.8.3 Maximizing The TOMAHAWK® Early Entry System

“The timing of concrete operations - especially finishing and jointing - is critical. Failure to address this issue can contribute to undesirable characteristics in the wearing surface, such as cracking” (Extract from the foreword of the American Concrete Institute (ACI) 302.1 R-96.)

In order for an operator to do a satisfactory job using the TOMAHAWK® Early Entry Concrete Saw system, the following criteria must be met:

- A TOMAHAWK® Early Entry Green Concrete Saw dry up-cut saw.
- A TOMAHAWK® Excel Series dry-cutting diamond blade.
- A TOMAHAWK® anti-ravel skid plate installed with every new diamond blade.
- An operator skilled in using the TOMAHAWK® Early Entry Green Concrete Saw cutting system

Without this criteria, joints can not be cut clearly enough to control random cracking before it starts.

The ACI Spec 302.1R-96 says it best:

“Early-entry dry-cut saws use diamond-impregnated blades and a skid plate that helps prevent spalling. Timely changing of skid plates is necessary to effectively control spalling. It is best to change skid plates in accordance with manufacturer’s recommendations...The goal of saw-cutting is to create a weakened plane as soon as the joint can be cut...The timing of the early-entry process allows joints to be in place prior to development of significant tensile stress in the concrete...”

5.8.4 Maximizing The Soft-Cut System Continued

The Portland Cement Association (PCA) engineering bulletin, Concrete Floors on the ground, also states: “Proper jointing can eliminate unsightly random cracks. Aspects of jointing that lead to a good job are choosing the correct type of joint for each location, establishing a good joint pattern and layout, and installing the joint at the correct time.

Timing of joint sawing is critical...Lightweight, high-speed, early-cut saws have been developed to permit the joint sawing very soon after floor finishing, sometimes within 0 to 2 hours...if the cut is sawn within a few hours after the final finishing, random cracking can be controlled...”

5.9 Lifting

The Early Entry Green Concrete Saw should be lifted from the CENTER handle on the roll cage.

- If two people are lifting the saw, use the roll cage bar on each side of the saw and lift with two hands.
- ALWAYS store the saw in a completely lowered position and secured from moving.
- Close the fuel valve.
- Secure the equipment during transportation in order to avoid transport damage and accidents.
- Store the equipment in a lockable area so that it is out of reach of children and unauthorized persons.
- Remove the blade BEFORE transportation or storage of the machine.
- Store the machine and its equipment in a dry and frost-proof place.

6. MAINTENANCE

6.1 Air Cleaner

- Wash the urethane foam filter (1) with detergent. Allow the filter to dry.
- Clean the paper element (2) by tapping gently to remove dirt and blow off dust.

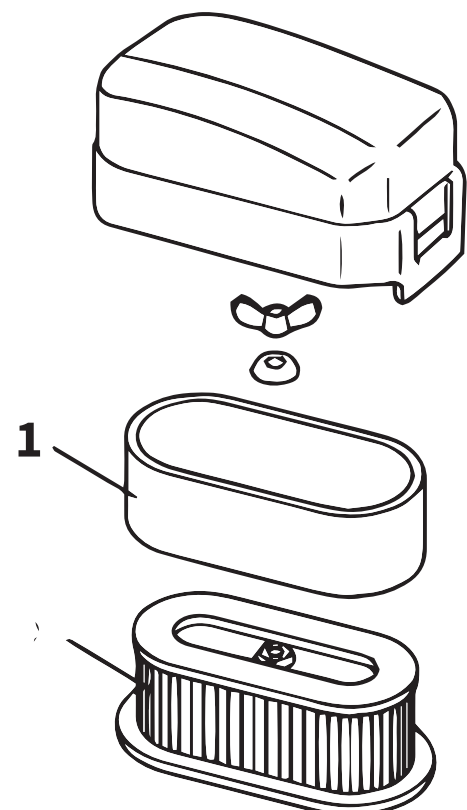

6.2 Spark Plug

- Ensure that the spark plug cap and ignition lead are undamaged to avoid the risk of electric shock.
- Clean off carbon deposits on the spark plug electrode using a plug cleaner or wire brush.

6.3 Fuel Cap

- Inspect fuel cap for water and dirt.
- To remove water and dirt, close the fuel tap and remove the fuel cap.
- After removing dirt and water, wash the fuel cup with kerosene or gasoline.
- Reinstall securely to prevent leakage.

6.4 Check

6.4.1 General Inspection

- Check that all nuts and screws are fastened tight.
- Check for any fuel or oil leakage.

6.4.2 Skid Plate

- Check for damage and excessive wear in the blade slot.
- Check for burrs on the concrete surface side and twisting.
- Install a new skid plate with each new blade. NEVER reuse skid plates.
- Lift the front and rear of the skid plate to ensure the blade can slide freely through the skid plate.

6.4.3 Oil Level

- Turn OFF the engine.
- Lower the machine and make sure the engine is level.
- Remove the oil cap and wipe the dipstick clean.
- Check the oil level. Do not screw the oil dipstick into the oil filler neck to check the oil level.
- If the oil level is low, fill using engine oil up to the upper level on the dipstick. See instructions in section “Technical data” for oil specification.
- Screw on the oil filler cap.

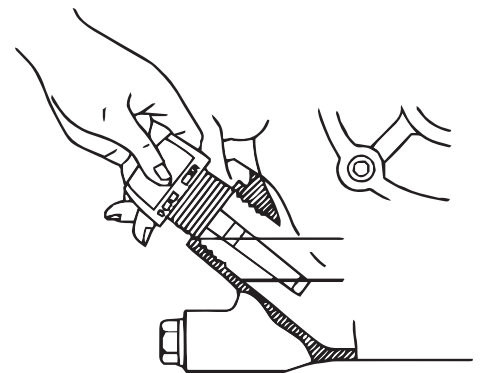

6.4.4 Drive Belt

- Check that the drive belt is not damaged and is not visibly defective.
- The belt tension is controlled by a belt tensioner and does not require adjustment.
- Inspect the belt tensioner to ensure free movement up and down.
- Ensure the belt tensioner bearings roll freely.

6.4.5 Blade Shaft Bearings

- Lubricate the blade shaft bearings with 3 pumps of Lithium-12 based grease.

6.4.6 Spark Plug and Electrode Gap

- Check the electrode gap.
- The gap should be 0.6 mm to 0.7 mm (0.02 inch.-0.03 inch).
- To adjust the gap, carefully bend the side of the electrode.
- Call TOMAHAWK® at 866-577-4476 if you need additional assistance checking your machine's spark plug.

6.5 Change

6.5.1 Oil

- Change the oil after the first 20 hours of use. After that, change every 100 hours.
- Change the engine oil while the engine is hot.
- Turn OFF the engine.
- Place a pan under the drain and remove the plug.
- Let the oil run out into the pan.
- Put the plug back and fill with new oil.
- When full, the oil level should be at the high level mark on the dipstick.

6.5.2 Oil Sensor

The engine is equipped with an oil alert system that will stop the engine if the oil level is low.

The engine cannot be started unless the level is raised above the prescribed limit.

6.5.3 Disposal

Used engine oil, antifreeze etc. is a health hazard and must not be disposed of on the ground or in nature; it should always be disposed of at a workshop or appropriate disposal location.

6.5.4 Additional Engine Information

Please see the engine Operator's Manual for additional information about servicing the engine.

The manual also contains specific information about specifications, tune-up parts, engine warranty, emission compliance, and more.

6.6 Replacement Parts

- For replacement parts and technical questions visit www.tomahawk-power.com or scan the QR code on the front of this manual.
- Not all equipment components are available for replacement. The illustrations within this manual are a convenient reference to the location and position of parts in the assembly sequence.
- When ordering parts, the following will be required: model number, serial number/lot date code, and description.
- The distributor reserves the right to make design changes and/or improvements to product lines and manuals without notice.

6.7 Maintenance Schedule

Maintain the screed in accordance with the following recommended procedures. Refer to the engine manufacturer's instruction manual for additional information about engine maintenance. The following chart is based on a normal operation schedule.

	DAILY BEFORE STARTING	AFTER FIRST 20 HOURS OR 3 MONTHS	AFTER FIRST 50 HOURS OR 6 MONTHS	AFTER FIRST 100 HOURS OR EVERY YEAR	AFTER FIRST 200 HOURS OR EVERY 2 YEARS
Check the fuel level	●				
Check the engine oil level	●				
Inspect the fuel lines	●				
Inspect the air filter and replace if needed	●				
Check and tighten the external hardware	●				
Change the engine oil		●			
Clean the air filter			●		
Change the engine oil			●		
Check and clean the spark plug			●		
Clean the fuel strainer				●	
Check and adjust the valve clearance					●
Clean the cylinder head					●
Replace the spark plug					●

7. TROUBLESHOOTING

Please check the list below before addressing the problems to servicing personnel including local dealer. And if the problem continues after the troubleshooting as described below, call your local dealer for future assistance.

Saw is spalling and raveling cut	Check to see if the diamond blade is worn out, glazed, warped or damaged.
	Ensure skid plate moves freely up and down the entire shaft length without contacting the diamond blade.
	Check skid plate for excessive wear or gap around the diamond blade.
	Check bottom of skid plate for metal burrs or irregularities.
	Ensure skid plate is not twisted or bent.
	Check lexan covers for free movement up and down.
	Ensure there is spring down pressure at each end of the skid plate.
	Do not twist or move the saw sideways while cutting. Make gradual changes in pressure on the handlebar to control the saw in the cut.
	Check that the engine is running properly and at full throttle.
	Check belt and belt idler for proper tension.
	Ensure the diamond blade is properly mounted and secured with clean flanges.
	Ensure that the diamond blade is the correct specification for your area.
	Ensure the slab is in clean with no debris that could raise the skid plate or saw while cutting.
	Use TOMAHAWK® joint protectors at all cut intersections.
	Clean excess concrete debris from the blade block assembly.
Check that the scrapers in the blade block are not bent or binding.	
Ensure that the blade block shafts are not bent or damaged.	
Saw pulls to one side while sawing	Check that the front guide is properly aligned with the center of the diamond blade.
	Check to see if the diamond blade is worn out, glazed, warped or damaged.
	Do not twist or move the saw sideways while cutting. Make gradual changes in pressure on the handlebar to control the saw in the cut
	Ensure that all wheels rolls freely and smoothly.
	Do not force the saw. Allow the diamond blade to cut at its own rate of speed.
Check the skid plate for damage or burrs.	
Engine does not start	Check if there is fuel in the tank and it is the correct fuel. Make sure there is no water in the fuel.
	Check if the fuel valve is turned to the 'on" position.
	Check if the ON/OFF switch is in the 'ON" position.
	Check that the spark plug wire is connected to the spark plug.
	Engine is flooded. Adjust the choke per the engine owner's manual.
	Check the choke is in the 'ON" position for cold starts. Adjust the choke per the engine owner's manual.
	Oil level is too low. Engine is equipped with an oil alert system that will not let the engine start unless the engine oil level is within the correct range.
	Check that air cleaner is not dirty or plugged.
Check that the blade shaft rotates freely and no concrete has built up in the blade block.	
Engine runs rough, back fires or can not reach full speed.	Check if there is fuel in the tank and it is the correct fuel. Make sure there is no water in the fuel.
	Oil level is too low. Engine is equipped with an oil alert system that will not let the engine start unless the engine oil level is within the correct range.
	Check that air cleaner is not dirty or plugged.
	Check that spark plug is clean and properly gapped.
	Check that throttle lever is properly set.
Check the choke is in the 'ON" position for cold starts. Adjust the choke per the engine owner's manual.	

TOMAHAWK

TFS10H
10" EARLY ENTRY CONCRETE SAW

Parts Manual

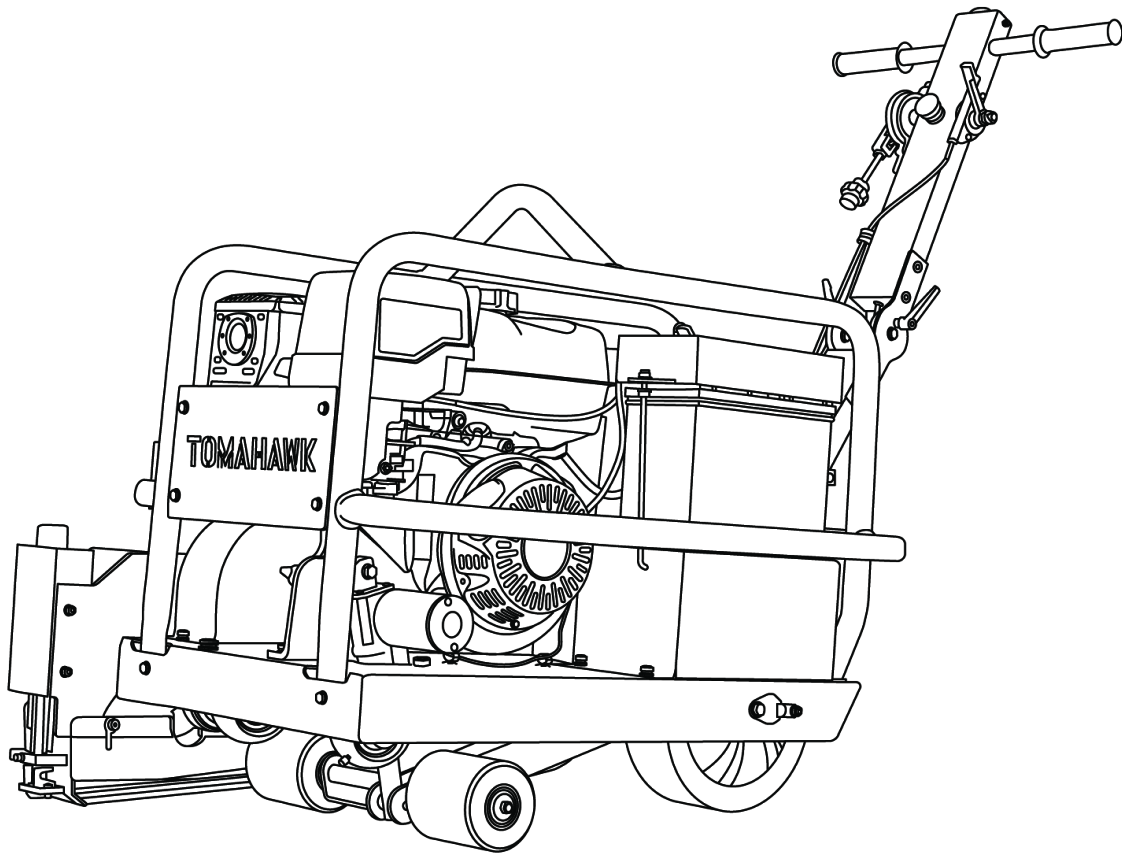

BLADE COVER SYSTEM

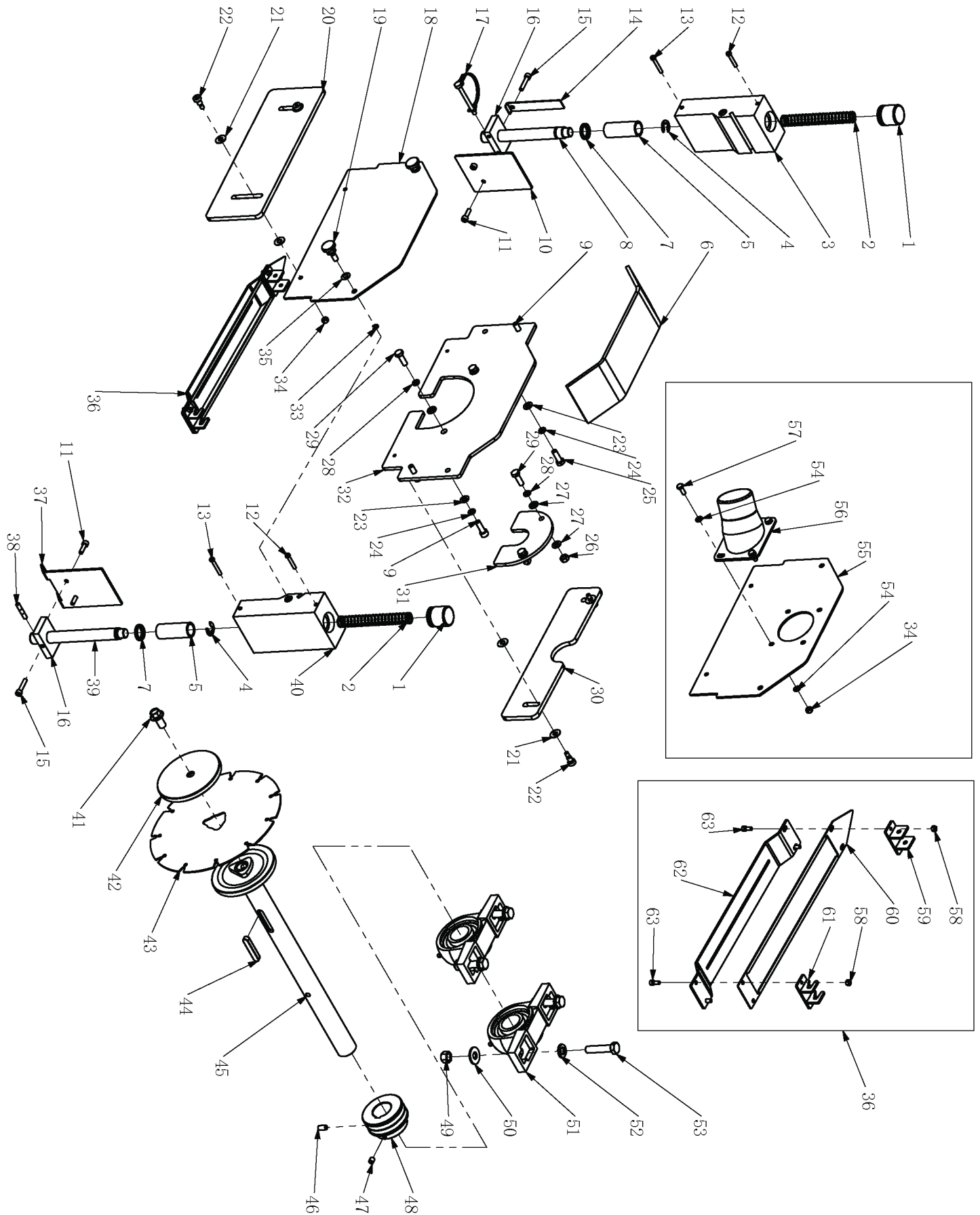

BLADE COVER SYSTEM

No.	Description	Drawing No.	Qty
1	Cap, Rod	1907-00070-1	2
2	Spring, Rod	1907-00079-4	2
3	Rare Blade Cover	1907-00072-1	1
4	Circlip $\Phi 12$	18120003	2
5	Bushing, Rod	1907-00068-1	2
6	Upper Blade Cover	1907-00074-2	1
7	Rubber Ring 20x28x3.5-5	2220283.506	2
8	Height Adjustment Rare Rod	1907-00073-1	1
9	Allen Screw M8x25	16082503	3
10	Rare Shield	1907-00078-2	1
11	Allen Screw M6x20	16062003	4
12	Allen Screw M5x30	16053020	2
13	Allen Screw M5x35	16053520	2
14	Indicator	1907-00080-2	1
15	Allen Screw M6x30	16063020	2
16	Spacer, Rod	1907-00071-1	2
17	D Pin	1906-00014-4	1
18	Outside Blade Cover	1907-00076-2	1
19	Bolt M8x20	16082008	2
20	Outside Shield	1907-00046-4	1
21	Washer $\Phi 8 \times 19 \times 1$	1904-00009-4	8
22	Bolt M6x $\Phi 8 \times 10$	16061010	4
23	Washer M8	11080000	4
24	Spring Washer M8	12080000	4
25	Bolt M8x25	15080250	1
26	Lock Nut M8	13080001	2
27	Washer M8	11080010	6
28	Spring Washer M8	12080010	4
29	Bolt M8x25	15082511	4
30	Inner Shield	1907-00045-4	1
31	Connecting Plate	1907-00044-2	1
32	Inner Blade Cover	1907-00075-2	1
33	Circlip $\Phi 6$	18060003	2
34	Lock Nut M6	13060001	6
35	Wave Washer M8x16x0.8	14080001	2
36	Skid	1907-08000-1	1
37	Front Shield	1907-00077-2	1
38	Pin $\Phi 6.35 \times 32$	1906.353202	1
39	Height Adjustment Front Rod	1907-00069-1	1
40	Front Blade Cover	1907-00067-1	1
41	Bolt M12x25	15122502	1
42	Outside Flange	1907-00047-1	1
43	10" Blade	1907-00048-4	1
44	Key 10x55	20100855A	1
45	Blade Shaft	1907-07000-3	1
46	Bolt M8x16	16081605	1
47	Set Screw M8x10	16081005	1

BLADE COVER SYSTEM

No.	Description	Drawing No.	Qty
48	Driven Pulley	1907-00049-4	1
49	Lock Nut M12	13120001	4
50	Washer M12x30x3	11123003	4
51	Bearing UCP207	21UCP207	2
52	Washer M12	11120000	4
53	Bolt M12x55	15120550	4
54	Washer M6	11060000	8
55	Outside Blade Cover (Vac Port)	1907-00094-2	1
56	Vac Port	1906-00051-4	1
57	Bolt M6x16	15060160	4
58	Nut M5	13050000	4
59	Front Connector, Skid	1907-08100-3	1
60	Indicator Plate	1907-08001-2	1
61	Rare Connector, Skid	1907-08200-3	1
62	Skid, Skid	1907-08002-2	1

ENGINE BASE AND ADJUSTMENT SYSTEM

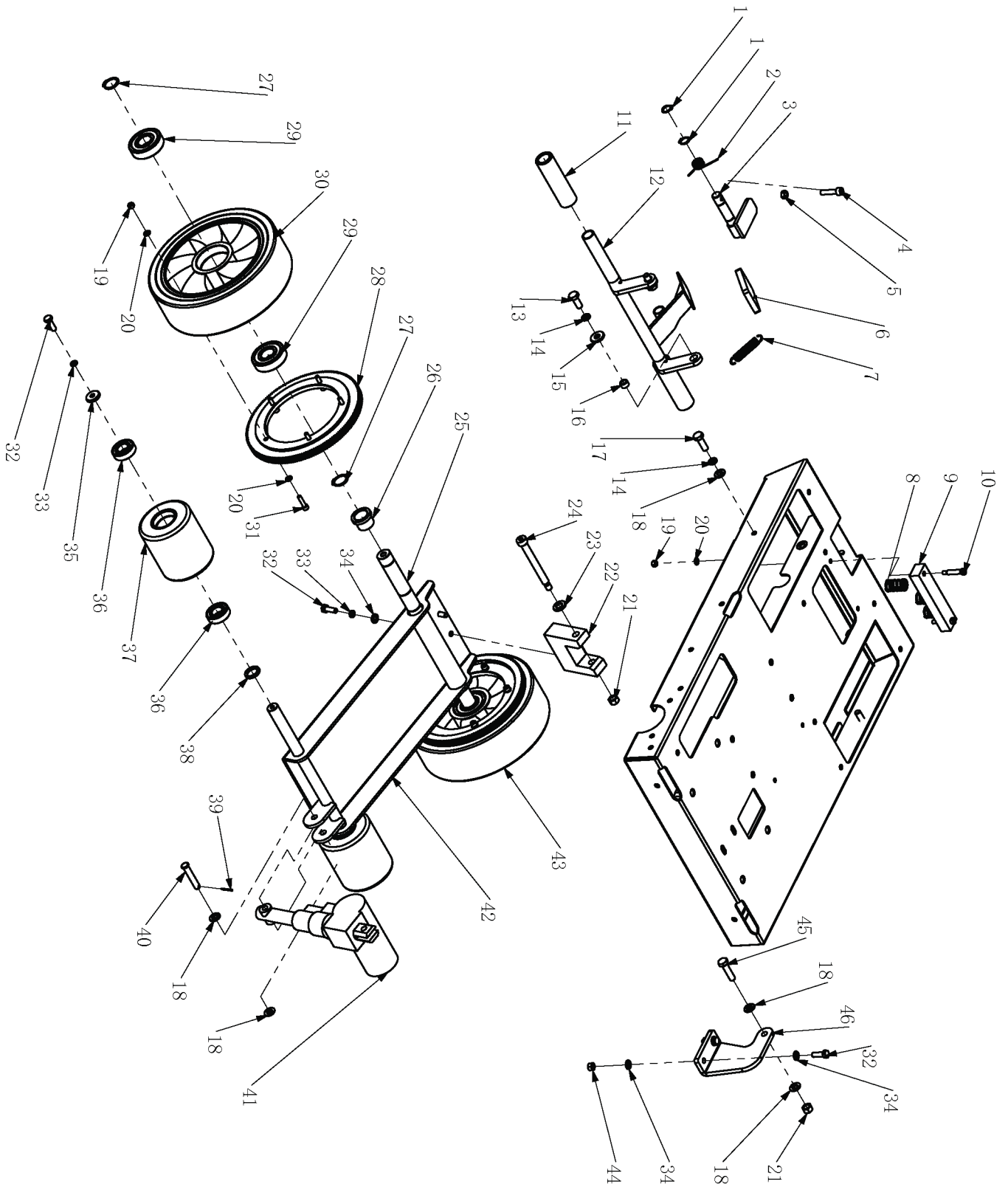

ENGINE BASE AND ADJUSTMENT SYSTEM

No.	Description	Drawing No.	Qty
1	Circlip Φ 16	18160001	2
2	Spring 1, Foot Brake	1907-00088-4	1
3	Foot Pedal, Foot Brake	1907-12000-3	1
4	Allen Screw M8x35	16083503	1
5	Nut M8	13080000	1
6	Rubber Pad, Foot Pedal	1907-00085-4	1
7	Spring 2, Foot Brake	1907-00087-4	1
8	Spring	1907-00030-4	3
9	Stopper	1907-00029-1	1
10	Bolt M6x Φ 8x30	16063010	2
11	Stopper	1107-00023-4	2
12	Frame, Foot Brake	1907-11000-3	1
13	Bolt M10x25	15100250	2
14	Spring Washer M10	12100000	4
15	Washer M10x25x3(10x26x3)	11102503	2
16	Bushing, Foot Brake	1907-00086-1	2
17	Bolt M10x30	15100300	2
18	Washer M10	11100000	6
19	Lock Nut M6	13060001	12
20	Washer M6	11060000	22
21	Lock Nut M10	13100001	2
22	Support	1907-00018-1	1
23	Washer M12	11120000	1
24	Bolt M10x Φ 12x100	161010010	1
25	Rare Shaft	1907-00013-1	1
26	Bushing	1907-00011-1	2
27	Circlip Φ 25	18250001	6
28	Gear 176x1.25	1907-00017-4	2
29	Bearing 6305-2R	216305-2R	4
30	Rare Right Wheel	1907-00015-1	1
31	Allen Screw M6x25	16062503	10
32	Bolt M8x25	15080250	6
33	Spring Washer M8	12080000	4
34	Washer M8	11080000	6
35	Washer M8x26x4	11082604	2
36	Bearing 6004-2R	216004-2R	4
37	Front Wheel	1907-00012-4	2
38	Spacer	70000048	2
39	Pin 2x20	19022003	1
40	Pin Φ 10x55	19105505	1
41	Linear Actuator	1907-00040-4	1
42	Carriage	1907-05000-3	1
43	Rare Left Wheel	1907-00014-1	1
44	Lock Nut M8	13080001	2
45	Bolt M10x40	15100400	1
46	Bracket, Linear Actuator	1907-00039-2	1

DRIVING SYSTEM AND FRAME

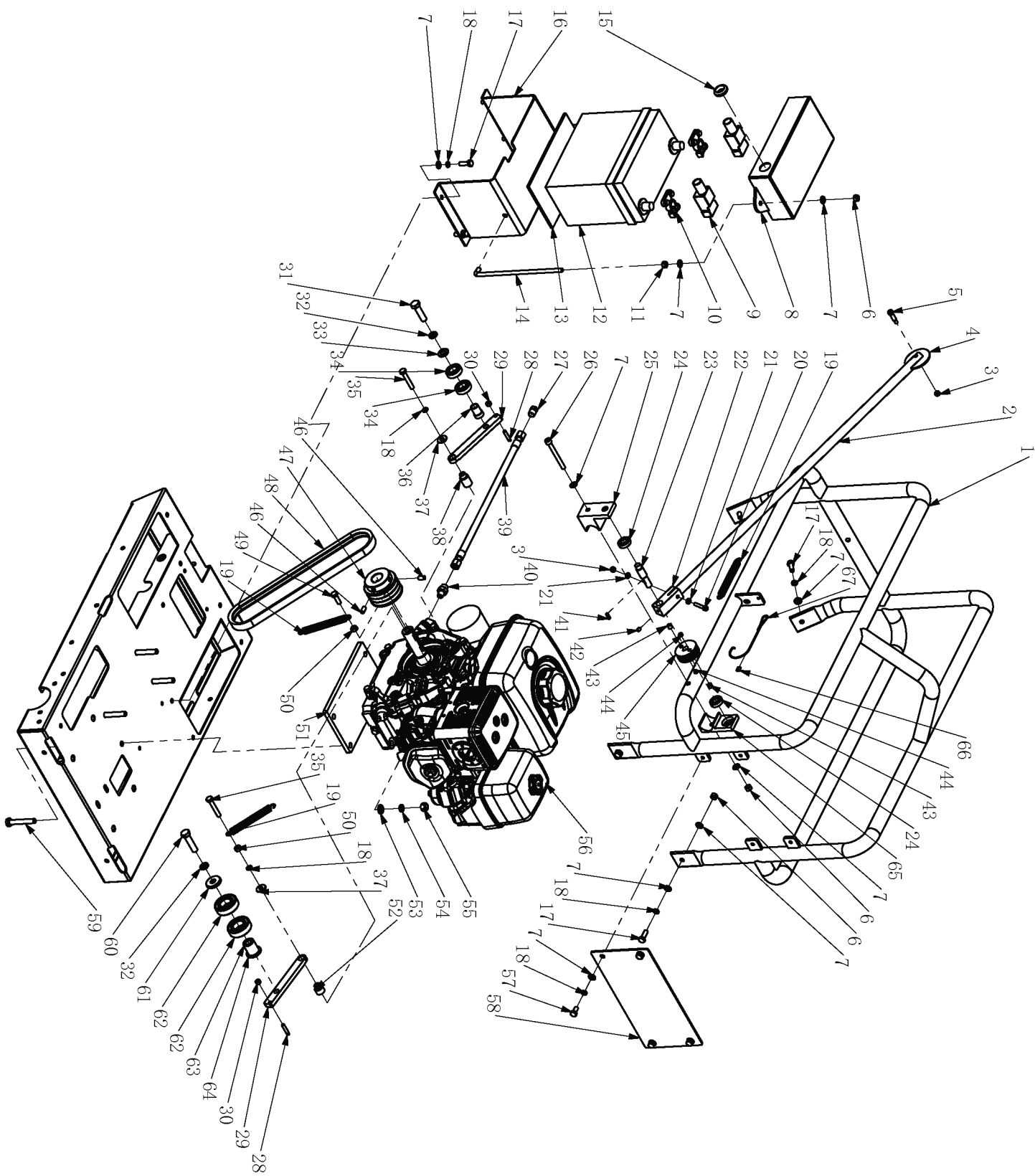

DRIVING SYSTEM AND FRAME

No.	Description	Drawing No.	Qty
1	Frame	1907-10000-3	1
2	Guide Rod	1907-00062-1	1
3	Lock Nut M6	13060001	2
4	Guide Wheel	1907-00065-1	1
5	Bolt M6xΦ8x20	16062010	1
6	Lock Nut M8	13080001	5
7	Washer M8	11080000	20
8	Battery Cap	1907-09000-3	1
9	Protective Cover	70000033	1
10	Battery Clamp	70000032	1
11	Nut M8	13080000	2
12	Battery	2304-20003-4	1
13	Rubber Pad	2304-00027-1	1
14	Support	1907-00056-1	2
15	Rubber Ring	70000054	1
16	Battery Base	1907-00055-2	1
17	Bolt M8x25	15080250	8
18	Spring Washer M8	12080000	14
19	Spring	1907-00051-4	3
20	Allen Screw M6x35	16063503	1
21	Washer M6	11060000	2
22	House, Guide Rod	1907-00061-1	1
23	Shaft, Guide Rod	1907-00059-1	1
24	Bearing 6001	216001-2Z	2
25	Right Support, Guide Rod	1907-00057-1	1
26	Allen Screw M8x80	16088017	1
27	Plug	1602-17003-4	1
28	Bolt M6x30	1906-00003-4	2
29	Tensioner Rod	1906-01001-2	2
30	Nut M6	13060000	2
31	Bolt M12x45	15120450	1
32	Spring Washer M12	12120000	2
33	Washer M12	11120000	1
34	Bearing 6003-2R	216003-2R	2
35	Bolt 5/16-24x2	15080500Y	2
36	Bushing	1906-01003-1	1
37	Washer M8x22x2	11082202	2
38	Bushing	1907-00053-1	1
39	Drain Hose	1605-00008-4	1
40	Drain Joint	1603-09001-4	1
41	Key 4x16	20040416A	1
42	Set Screw M6x8	16060805	1
43	Set Screw M8x10	16081005	2
44	Set Screw M8x6	16080605	2
45	Wheel, Guide Rod	1907-00060-1	1
46	Bolt M8x16	16081605	2
47	Driving Pulley	1907-00052-4	1

DRIVING SYSTEM AND FRAME

No.	Description	Drawing No.	Qty
48	Belt	273V(9J)840La-2	1
49	Bolt 5/16-24x1	15080300Y	1
50	Nut 5/16-24	13080000Y	2
51	Engine Pad	1907-00054-1	1
52	Bushing	1906-01002-1	1
53	Washer M10	11100000	4
54	Spring Washer M10	12100000	4
55	Lock Nut M10	13100001	4
56	Engine		1
57	Bolt M8x16	15080160	4
58	Front Plate	1907-00066-2	1
59	Bolt M10x65	15100650	4
60	Bolt M12x50	15120500	1
61	Washer M12x35x5	11123505	1
62	Bearing 6205	1905-00060-4	2
63	Shaft, Tensioner	1907-00050-1	1
64	Washer	70000049	1
65	Left Support, Guide Rod	1907-00058-1	1
66	Bushing	70000097	1
67	Stay Wire	1907-00063-1	1

HANDLE AND BELT COVER

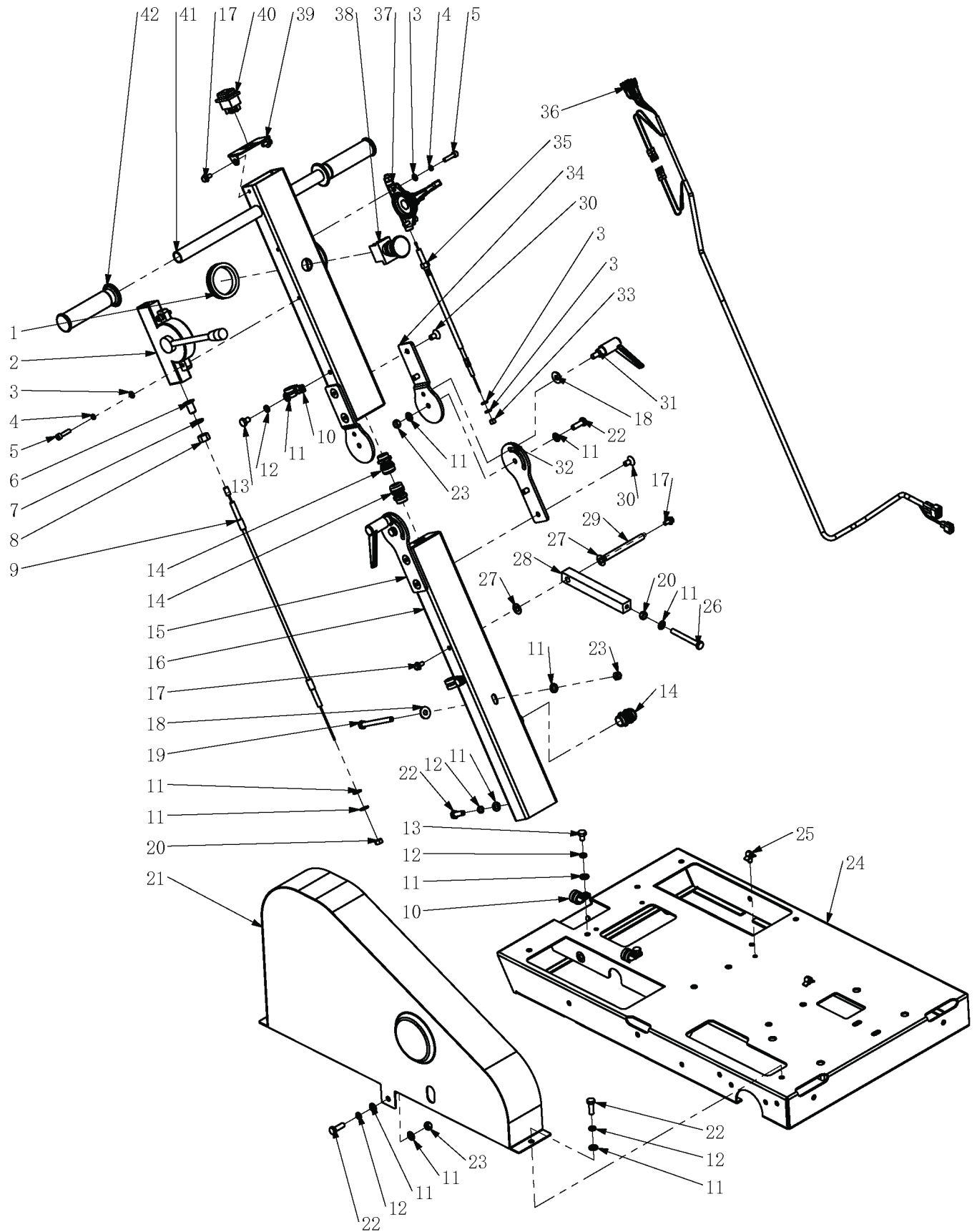

HANDLE AND BELT COVER

No.	Description	Drawing No.	Qty
1	Back Cover, Emergency Stop	1907-00092-4	1
2	Guide Rod Lever	1907-00007-4	1
3	Washer M6	11060000	6
4	Spring Washer M6	12060000	4
5	Allen Screw M6x25	16062503	4
6	Joint	1907-00091-1	1
7	Washer M12	11120000	1
8	Nut M12	13120000	1
9	Guide Cable	1907-00009-4	1
10	Clamp Φ 16	70000021	4
11	Washer M8	11080000	18
12	Spring Washer M8	12080000	9
13	Bolt M8x12	15080120	4
14	Joint, Electrical Box	70000029	3
15	Right Lower Connector, Handle	1907-00004-2	1
16	Lower Handle	1907-03000-3	1
17	Bolt M6x12	15060122	4
18	Washer M8x22x2	11082202	3
19	Bolt M8x90	15080901	1
20	Nut M8	13080000	2
21	Belt Cover	1907-04000-3	1
22	Bolt M8x25	15080250	7
23	Lock Nut M8	13080001	4
24	Engine Base	1907-01000-3	1
25	Wire Clip Φ 9	70000002	2
26	Bolt M8x70	15080700	1
27	Washer Φ 10x20x1	1907-00089-4	2
28	Connect Rod	1907-00008-1	1
29	Shaft	1907-00084-1	1
30	Allen Screw M8x16	16081604	8
31	Locking Handle M8x16	28080164	2
32	Left Lower Connector, Handle	1907-00003-2	1
33	Nut M6	13060000	1
34	Upper Connector, Handle	1907-00002-2	2
35	Travelling Lever	1907-00090-4	1
36	Wire 1	1907-13000-1	1
37	Trottle Lever Assy.	2302-09000-3	1
38	Emergency Switch	2403-00147-4	1
39	Base, Depth Switch	1907-00005-2	1
40	Depth Switch	1907-00006-4	1
41	Upper Handle	1907-02000-3	1
42	Handle Grip	70220000	2

HYDRAULIC AND ELECTRONIC SYSTEM

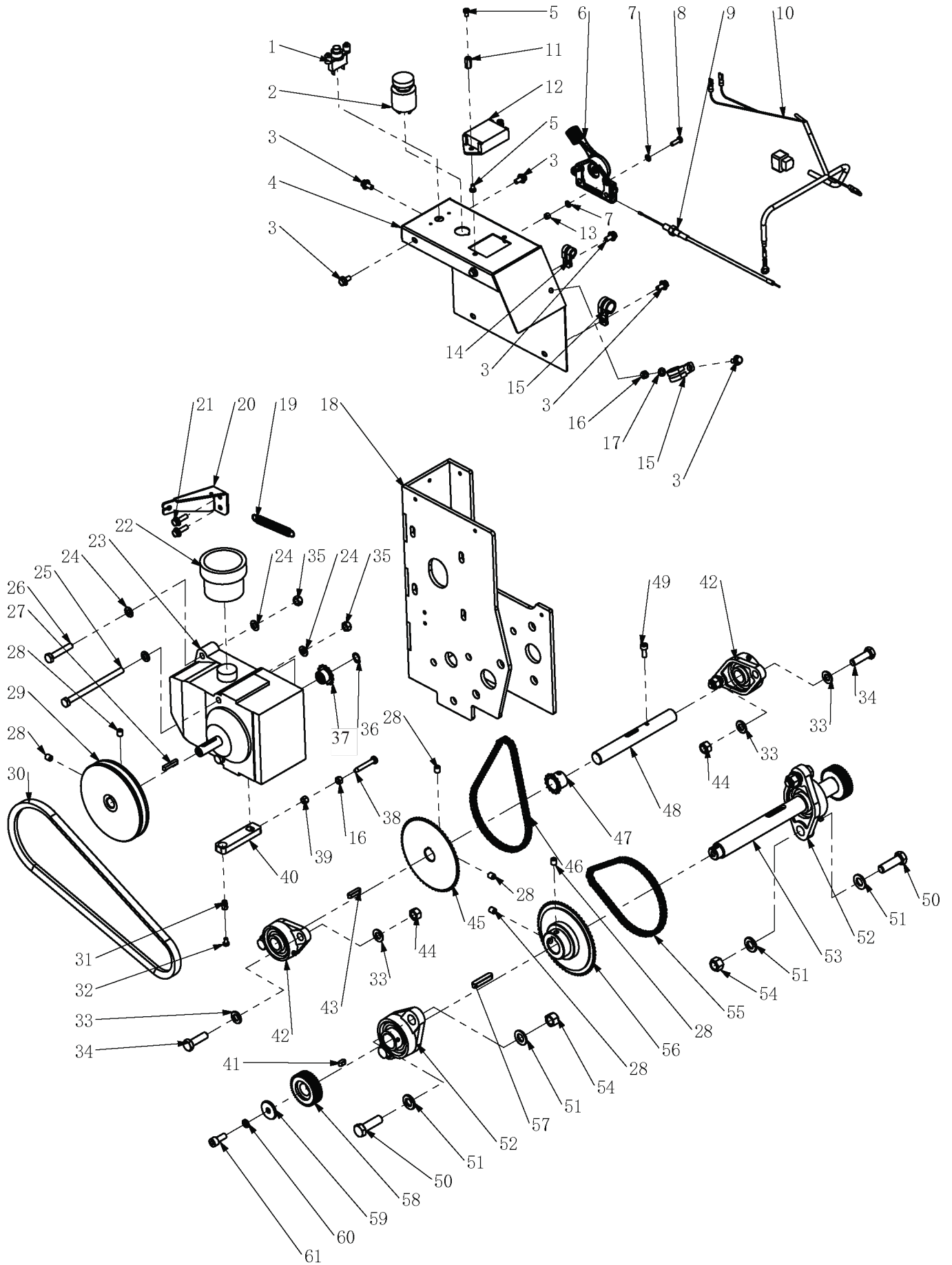

HYDRAULIC AND ELECTRONIC SYSTEM

No.	Description	Drawing No.	Qty
1	Battery Protector		1
2	Keyhole	2403-00153-4	1
3	Bolt M6x12	15060122	7
4	Upper Shield, Hydraulic Motor	1907-00019-2	1
5	Screw M5x8	16050801	4
6	Throttle Lever Assy.	1107-06000-1	1
7	Washer M5	11050000	4
8	Bolt M5x16	15051600	2
9	Trottle Wire	1104-00032-4	1
10	Wire 2	1907-15000-1	1
11	Nut	1907-00024-1	2
12	Techometer	70000025	1
13	Lock Nut M5	13050001	2
14	R Clamp Φ 9	70000001	1
15	Clamp Φ 16	70000021	2
16	Lock Nut M6	13060001	2
17	Washer M6	11060000	1
18	Base, Hydraulic Motor	1907-06000-3	1
19	Spring	1907-00096-4	1
20	Clamping Plate, Travelling Cable	1907-00034-2	1
21	Bolt M6x20	15060202	2
22	Oil Inlet	1907-00083-4	1
23	Hydraulic Motor	1907-00082-4	1
24	Washer M8	11080000	8
25	Bolt M8x120	15081200	2
26	Bolt M8x45	15080450	2
27	Key 5x30	12050530A	1
28	Set Screw M8x10	16081005	6
29	Pulley, Hydraulic Motor	1907-14000-3	1
30	Belt	273V(9J)900La	1
31	Lock Nut	2204-00021-4	1
32	Bolt M5x8	15050080	1
33	Washer M10	11100000	8
34	Bolt M10x35	15100350	4
35	Lock Nut M8	13080001	4
36	Circlip Φ 12	18120001	1
37	First Driving Chain Gear	1907-00023-4	1
38	Bolt	1907-00095-1	1
39	Nut M6	13060000	1
40	Arm	1907-00027-1	1
41	Key 6x20	20060620A	2
42	Bearing UCFL204	21UCFL204	2
43	Key 6x25	20060625A	1
44	Lock Nut M10	13100001	4
45	First Driven Chain Gear	1907-00020-4	1
46	First Chain	1907-00032-1	1

HYDRAULIC AND ELECTRONIC SYSTEM

No.	Description	Drawing No.	Qty
47	Second Driving Chain Gear	1907-00021-4	1
48	First Shaft	1907-00037-1	1
49	Allen Screw M6x16	16061603	1
50	Bolt M12x40	15120400	4
51	Washer M12	11120000	8
52	Bearing UCFL205	21UCFL205	2
53	Second Shaft	1907-00036-1	1
54	Lock Nut M12	13120001	4
55	Second Chain	1907-00031-1	1
56	Second Driven Chain Gear	1907-00022-4	1
57	Key 8x40	20080740A	1
58	Gear 40x1.25	1907-00038-4	2
59	Washer M8x30x3	11083003	2
60	Spring Washer M8	12080000	2
61	Allen Screw M8x35	16082003	2



FINISH 4X FASTER

Master your next concrete job with power screeds from **TOMAHAWK!** Achieve incredible finishes 4x faster than traditional methods to increase crew efficiency and jobsite profit! Choose magnesium or aluminum screed boards from 4ft to 14ft long.



Item #: TVSA-H
4'-6'-8'-10'-12'-14'
POWER SCREEDS

www.tomahawk-power.com 



TOMAHAWK

PRODUCT CATALOG

COMPACTION



HONDA
ENGINES

3,550 lbs/ft Vibratory Rammer
Part#: TR68H

3.6 HP Honda GXR120 Engine
Easily achieve a 100% compaction rating
3-in-One Fuel System with carburetor protection
13" x 11" plate for narrow trenches and corners
3 Year Engine Warranty & 1 Year Product Warranty



HONDA
ENGINES

3,400 lbs/ft Plate Compactor
Part#: TPC90H

5.5 HP Honda GX160 Engine
Easily achieve a 100% compaction rating
22" x 20" cold, rolled steel beveled base plate
Includes 3.5 gallon water tank for asphalt compaction
3 Year Engine Warranty & 1 Year Product Warranty



HONDA
ENGINES

KOHLER
ENGINES

3,000 lbs/ft Plate Compactor
Part#: TPC80 & TPC80H

6 HP Kohler CH260 & 5.5 HP Honda GX160 Engines
Easily achieve a 100% compaction rating
16.5" x 21.5" plate for narrow trenches and corners
Optional Honda Engine model: TPC80H
3 Year Engine Warranty & 1 Year Product Warranty

FINISHING



6.5 Gal Backpack Concrete Sprayer
Part#: TCS6.5

Maintain constant, adjustable pressure up to 450 PSI
Achieve superior concrete finishes with even spraying
Spray 15,000 sq ft in less than 10 minutes
Compatible with major manufacturer wands
1 Year Product Warranty

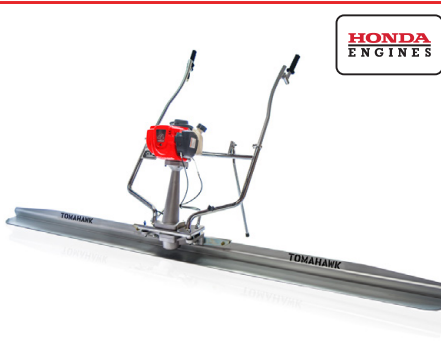

HONDA
ENGINES

1.6 HP Vibratory Concrete Screed
Part#: TVSA-H

1.6 HP Honda GX35 Engine
Aluminum Magnesium blades available from 8ft - 14ft
Finish concrete 4X faster than other screed methods
360° adjustable handle placement
3 Year Engine Warranty & 1 Year Product Warranty

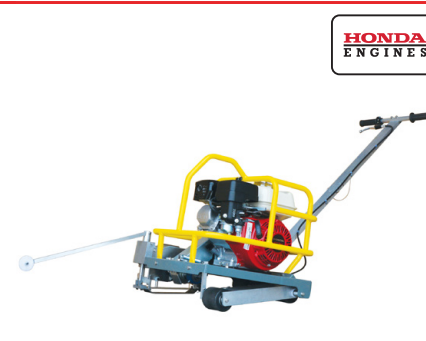

HONDA
ENGINES

6" Early Entry Green Concrete Saw
Part#: TFS6H

5.5 HP Honda GX160 Engine
Maximum cutting depth of 1 3/16 inches
OSHA compliant vacuum port for dust collection
Includes 6" early entry concrete blade
3 Year Engine Warranty & 1 Year Product Warranty

FINISHING



HONDA
ENGINES

1.6HP Backpack Concrete Vibrator
Part#: TVIBH + TVW10-P

1.6 HP Honda GX35 engine
Consolidation with speeds of 10,000-12,000 VPM
Quick Connect centrifugal clutch vibrator
1" and 2" Diameter Whips Available in 10ft Length
3 Year Engine Warranty & 1 Year Product Warranty

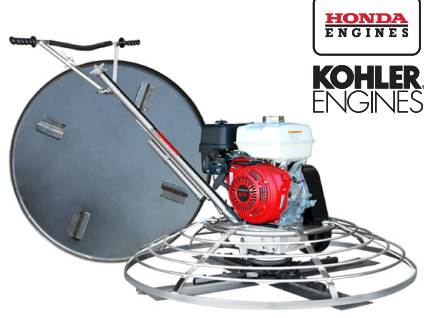

HONDA
ENGINES

KOHLER
ENGINES

36" & 46" Concrete Power Trowel
Part#: TPT36H/K & TPT46H/K

6 HP/14HP Kohler & 5.5HP/8.5HP Honda Engines
Adjust trowel blade pitch from 0-28°
60-115 RPM rotor speed for superior concrete finishes
Includes float pan and trowel blades
3 Year Engine Warranty & 1 Year Product Warranty



HONDA
ENGINES

8" Gas Powered Concrete Scarifier
Part#: TSCAR8H

5.5 HP Honda GX160 Engine
Remove traffic lines at 800 - 1,000 linear ft/hr
Tungsten Carbide Blade Kit Available
OSHA approved dust port for silica vacuum removal
3 Year Engine Warranty & 1 Year Product Warranty

HAVE QUESTIONS?

Contact us. *We're here to help!*

Email us at sales@tomahawk-power.com



USE CODE **SAVE10**
AT CHECKOUT FOR
10% OFF YOUR ORDER AT
WWW.TOMAHAWK-POWER.COM

POWER / WELDING

INVERTER SERIES



2000 Watt Inverter Generator
Part#: TG2000i

2000 Max Watts, 1600 Rated Watts
Run Time of 8 hours on 1 gallon of gas
OSHA and GFCI Compliant
Parallel technology capable for double the power
2 Year Product Warranty

INVERTER SERIES



210 Amp Portable Welder Generator
Part#: TWG210A

Steady 50 - 210 Amp DC welding output
60% Duty Cycle for extended use
Suitable for welding rods from 6010 to 7024
Electric Key Start with battery included
2 Year Product Warranty



7000 Watt Generators
Part#: TG7000

7000 Max Watts, 5500 Rated Watts
Voltage Selector gives Full Wattage for 120V or 240V
Run Time of 8 hours at 50% Load
OSHA and GFCI Compliant
2 Year Product Warranty

PEST CONTROL



3.7 Gallon 3HP Backpack Fogger
Part#: TMD14

Turbo Boosted Pump with 40ft + Horizontal Reach
Sprays 1 acre in 30 minutes
10X Faster than Manual Pump Sprayers
Converts to Leaf Blower with 200 MPH Air Velocity
1 Year Product Warranty



4.75 Gallon Battery Power Sprayer
Part#: eTPS18

Reach Up to 30ft Horizontal Reach
Sprays 6000 sq ft in 10 minutes
10X Faster than Manual Pump Sprayers
70 PSI Commercial Grade Pump
1 Year Product Warranty



5 Gallon Backpack Power Sprayer
Part#: TPS25

Reach Up to 30ft Horizontal Reach
Sprays acres in 10 minutes
10X Faster than Manual Pump Sprayers
50-435 Adjustable PSI Commercial Grade Pump
1 Year Product Warranty

AND MORE



4 Gal. Backpack Fertilizer Spreader
Part#: TGS30

Reach up to 30ft Horizontally
Sprays 1 acre in 30 minutes
20X Faster than push spreaders
Converts to Leaf Blower with 200 MPH Air Velocity
1 Year Product Warranty



3" Full Trash Water Pump
Part#: TW3H

Moves liquids at a rate up to 375 gal/min
Handle solids up to 1.5"
Silicone carbide seals and a chrome plated volute
8 HP engine protected by rugged all purpose frame
3 Year Engine Warranty & 1 Year Product Warranty



Commercial 38" Push Sweeper
Part#: TOS38

Collect up to 14.5 gallons of dust and debris
Can be used indoors & outdoors on wet or dry surfaces
Includes integrated airflow control and fine dust filter
Lightweight design, capable of fitting through doorways
1 Year Product Warranty

ASSEMBLED IN THE
USA
PARTS SOURCED GLOBALLY

* All coupons in this manual are valid only for orders placed on www.tomahawk-power.com, unless otherwise noted. Coupon codes may only be used once per customer and may not be combined with any other offer. Coupons may expire at any time without notice.

(866) 577-4476

www.tomahawk-power.com





POWER YOUR WORLD

TOMAHAWK® understands to keep a job-site running smoothly the proper equipment and spare parts are needed at the drop of a hat. With same day shipping and faster delivery times, count on TOMAHAWK® to keep you powered throughout the day! With long lasting parts and engines, TOMAHAWK® equipment will be the star of your fleet for years to come. Visit www.tomahawk-power.com to get started today!

TOMAHAWK

TOMAHAWK POWER, LLC
San Diego, CA

Sales Support
(866) 577-4476
sales@tomahawk-power.com

Equipment Support
(866) 577-4476
support@tomahawk-power.com

www.tomahawk-power.com



FACEBOOK
facebook.com/TomahawkPowerUSA

YOUTUBE
youtube.com/TomahawkPower

INSTAGRAM
[@tomahawkpower](https://instagram.com/tomahawkpower)