

SEARS OWNER'S MANUAL

MODEL NO.

580.751651

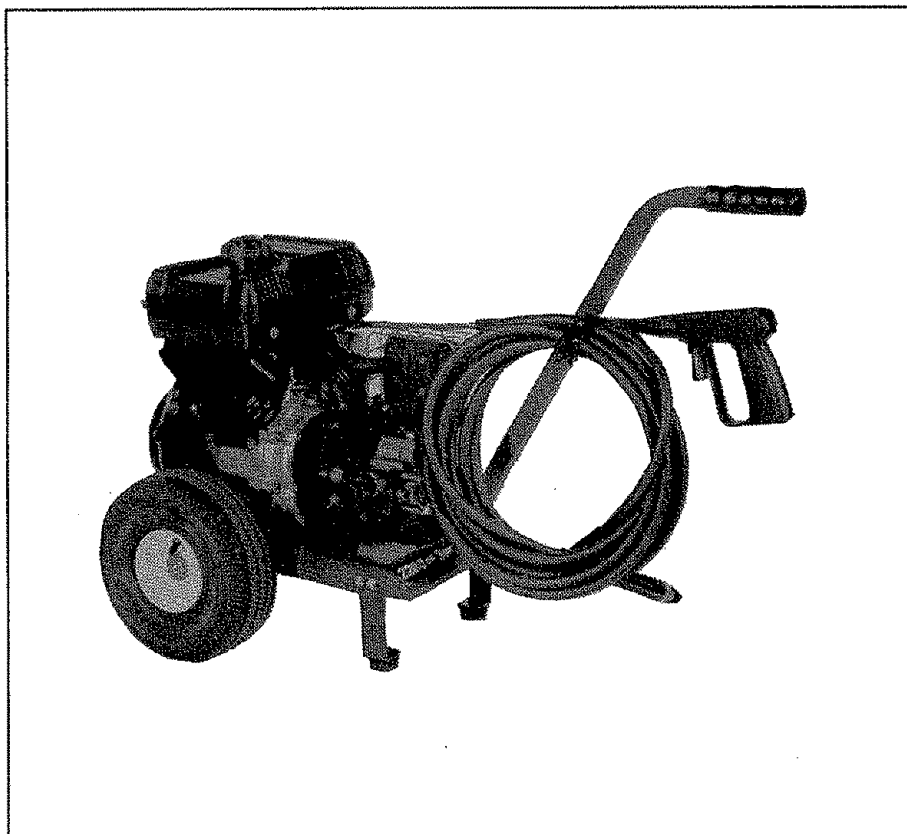

**PRESSURE WASHER
CUSTOMER
HELPLINE
1-800-222-3136**

**HOURS:
Mon. - Fri. 8 a.m. to 5 p.m.
(CST)**

**CAUTION:
Read and Follow
all Safety Rules
and Instructions
Before Operating
This Equipment**

CRAFTSMAN®

**6.5 HORSEPOWER
2200 PSI 3 GPM
HIGH PRESSURE WASHER**

- Assembly
- Operation
- Customer Responsibilities
- Service and Adjustment
- Repair Parts

SEARS, ROEBUCK and CO., Hoffman Estates, IL 60179 U.S.A.

SAFETY RULES



CAUTION: ALWAYS DISCONNECT SPARK PLUG WIRE AND PLACE WIRE WHERE IT CANNOT CONTACT SPARK PLUG, TO PREVENT ACCIDENTAL STARTING WHEN SETTING UP, TRANSPORTING, ADJUSTING OR MAKING REPAIRS TO YOUR HIGH PRESSURE WASHER.



TRAINING:

- Engine exhaust gases contain **DEADLY** carbon monoxide gas. This dangerous gas, if breathed in sufficient concentrations, can cause unconsciousness or even death. Operate this equipment only in the open air where adequate ventilation is available.
- **WARNING:** Engine exhaust from this product contains chemicals, known, in certain quantities, to cause cancer, birth defects, or other reproductive harm.
- Gasoline is highly **FLAMMABLE** and its vapors are **EXPLOSIVE**. Do not permit smoking, open flames, sparks or heat in the vicinity while handling gasoline. Avoid spilling gasoline on a hot engine. Allow unit to cool for 2 minutes before refueling. Comply with all laws regulating storage and handling of gasoline.
- Locate this pressure washer in areas away from combustible materials, combustible fumes or dust.
- The high pressure equipment is designed to be used with Sears authorized parts only. If you use this equipment with parts that do not comply with minimum specifications, the user assumes all risks and liabilities.
- Some chemicals or detergents may be harmful if inhaled or ingested, causing severe nausea, fainting or poisoning. The harmful elements may cause property damage or severe injury.
- Do not allow **CHILDREN** to operate the Pressure Washer at any time.

PREPARATION:

- Operate engine only at governed speed. Running the engine at excessive speeds increases the hazard of personal injury. Do not tamper with parts which may increase or decrease the governed speed.
- Do not wear loose clothing, jewelry or anything that may be caught in the starter or other rotating parts.
- Before starting the Pressure Washer in cold weather, check all parts of the equipment and be sure ice has not formed there.
- Units with broken or missing parts, or without protective housing or covers should **NEVER** be operated.
- The muffler and air cleaner must be installed and in good condition before operating the Pressure Washer. These components act as spark arrestors if the engine backfires.
- Check the fuel system for leaks or signs of deterioration such as chafed or spongy hose, loose or missing clamps or damaged tank or cap. Correct all defects before operating the Pressure Washer.

OPERATION:

- Do not spray flammable liquids.
- Never aim the gun at people, animals or plants.
- Never allow any part of the body to come in contact with the fluid stream. **DO NOT** come in contact with a fluid stream created by a leak in the high pressure hose.
- High pressure stream of fluid that this equipment can produce can pierce skin and its underlying tissues, leading to serious injury and possible amputation.

- High pressure spray can cause paint chips or other particles to become airborne and fly at high speeds.
- Always wear eye protection when you use this equipment or when you are in the vicinity where the equipment is in use.
- Operate the pressure at no more than the PSI fluid pressure rated for your pressure washer.
- Never move the machine by pulling on the high pressure hose. Use the handle provided on the top of the unit.
- Always be certain the spray gun, nozzles and accessories are correctly attached.
- Never use a spray gun which does not have a trigger lock or trigger guard in place and in working order.
- Use a respirator or mask whenever there is a chance that vapors may be inhaled. Read all instructions with the mask so you are certain the mask will provide the necessary protection against inhaling harmful vapors.
- High pressure spray may damage fragile items including glass. Do not point spray gun at glass when in the jet spray mode.
- Keep the hose connected to machine or the spray gun while the system is pressurized. Disconnecting the hose while the unit is pressurized is dangerous.
- Hold the spray gun firmly in your hand before you start the unit. Failure to do so could result in an injury from a whipping spray gun. Do not leave the spray gun unattended while the machine is running.
- The cleaning area should have adequate slopes and drainage to reduce the possibility of a fall due to slippery surfaces.
- Keep water spray away from electric wiring or fatal electric shock may result.
- Do not adjust unloader valve to a pressure in excess of machine rating.
- Do not secure trigger gun in the pull-back (open) position.
- Do not by-pass any safety device on this machine.
- Do not leave trigger closed for more than 5 minutes with engine running. This could damage the pump.
- The muffler and engine heat up during operation and remain hot immediately after shutting it down. Avoid contact with a hot muffler or engine or you could be severely burned.

MAINTENANCE AND STORAGE:

- Operate and store this unit on a stable surface.
- High pressure hose can develop leaks from wear, kinking, abuse, etc. Water spraying from a leak is capable of injecting material into skin. Inspect hose each time before using it. Check all hoses for cuts, leaks, abrasions or bulging of cover, or damage or movement of couplings. If any of these conditions exist, replace hose immediately. Never repair high pressure hose. Replace it with another hose that meets minimum pressure rating of your pressure washer.



LOOK FOR THIS SYMBOL TO POINT OUT IMPORTANT SAFETY PRECAUTIONS. IT MEANS "ATTENTION!!! BECOME ALERT!!! YOUR SAFETY IS INVOLVED."

CONGRATULATIONS on your purchase of a Sears Craftsman high pressure washer. It has been designed, engineered and manufactured to give you the best possible dependability and performance.

Should you experience any problem you cannot easily remedy, please contact your nearest Sears Service Center/Department or call the 1-800 number listed on the front of this manual. We have competent, well-trained technicians and the proper tools to service or repair this unit.

Please read and retain this manual. The instructions will enable you to assemble and maintain your high pressure washer properly. Always observe the "SAFETY RULES."

MODEL NUMBER	580.751651
SERIAL NUMBER	_____
DATE OF PURCHASE	_____
THE MODEL AND SERIAL NUMBERS WILL BE FOUND ON A DECAL ATTACHED TO THE PRESSURE WASHER.	
YOU SHOULD RECORD BOTH SERIAL NUMBER AND DATE OF PURCHASE AND KEEP IN A SAFE PLACE FOR FUTURE REFERENCE.	

MAINTENANCE AGREEMENT

A Sears Maintenance Agreement is available on this product. Contact your nearest Sears store for details.

CUSTOMER RESPONSIBILITIES

- Read and observe the safety rules.
- Follow regular schedule in maintaining, caring for and using your high pressure washer.
- Follow the instructions under "Customer Responsibilities" and "Storage" sections of this Owner's Manual.

PRODUCT SPECIFICATIONS

Pressure Washer Specifications

PUMP PRESSURE	Adjustable to 2200 psi
FLOW RATE	3 gpm
DETERGENT MIX	Use undiluted detergent
DETERGENT RATIO	Adjustable to 73:1
WATER SUPPLY TEMPERATURE	Not to exceed 140°F
SUCTION HEIGHT	3 FT. maximum

Engine Specifications

ENGINE MODEL	GN-Series
RATED HORSEPOWER	6.5
DISPLACEMENT	190cc
SPARK PLUG: Type:	Champion RC12YC or equivalent
Set Gap To.	0.030 inch (0.76mm)
GASOLINE CAPACITY	1 U.S. gallon
OIL (20 oz. capacity)	SAE 30 weight
SOLID STATE IGNITION AIR GAP	0.0125 inch

NOTE: The engine of the pressure washer is equipped with a spark arrestor muffler. The spark arrestor must be maintained in effective working order by the owner/operator.

In the State of California a spark arrestor is required by law (Section 4442 of the California Public Resources Code). Other states may have similar laws. Federal laws apply on federal lands.

TABLE OF CONTENTS

SAFETY RULES	2	CUSTOMER RESPONSIBILITIES	14-16
PRODUCT SPECIFICATIONS	3	SERVICE AND ADJUSTMENTS	17
ACCESSORIES AND ATTACHEMENTS	5	STORAGE	18
CONTENTS OF HARDWARE PACK.....	6	TROUBLESHOOTING.....	19
ASSEMBLY.....	7-8	REPLACEMENT PARTS.....	20-26
OPERATION	9-13	WARRANTY	27

- A -

Air Cleaner	9,16
Assembly	
Removing from Carton	7
Tools Required	7
Set Up	7-8

- B -

Before Starting	11-12
-----------------------	-------

- C -

Customer Responsibilities	
Statement	3
Schedule	14-16
Changing Oil	15
Checking Oil Level	15
General Recommendations ...	14
Pressure Washer	14
Pump	15
Replace Spark Plug	16
Service Air Cleaner.....	16
Spark Arrestor.....	16

- E -

Engine Speed	17
--------------------	----

- G -

Gun and Wand Assembly... ..	8,9
-----------------------------	-----

- H -

Hardware Pack	6
High Pressure Hose.....	6,8

- L -

Low Oil Pressure System ...	13
-----------------------------	----

- M -

Maintenance	
Engine	15
Pump	15

- O -

Oil, Engine	3,11
Operation	
Detergent Application	11
Stopping	10
To Start Engine	12
To Turn On Washer.....	12
To Use	10

- P -

Pressure Regulator	10
--------------------------	----

- R -

Repair Parts	20-26
--------------------	-------

- S -

Safety Latch	12
Safety Rules	2
Service and Adjustments .	17-18
Storage	18
Engine.....	18
Pressure Washer Pump.....	18

- T -

Troubleshooting	19
-----------------------	----

- V -

Valve, thermal relief	13
-----------------------------	----









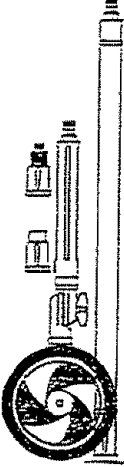

- W -

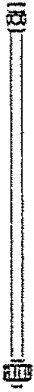
Warranty	27
----------------	----

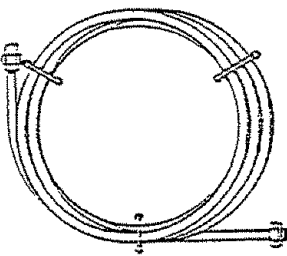
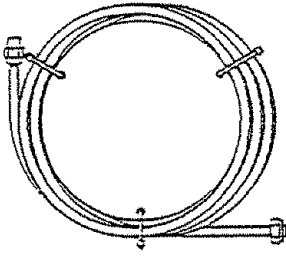
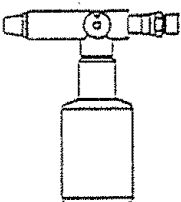

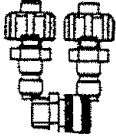
ACCESSORIES AND ATTACHMENTS

These accessories and attachments were available when the high pressure washer was purchased. They are also available at most Sears retail outlets and service centers. Most Sears stores can order these items for you when you provide the model number of your high pressure washer. Some of these accessories may not apply to your pressure washer.

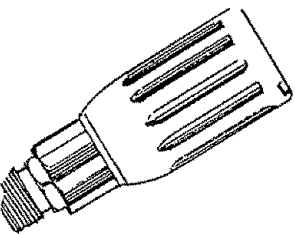
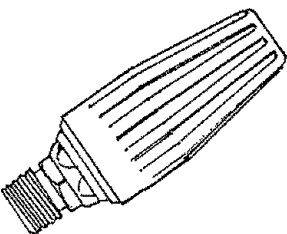
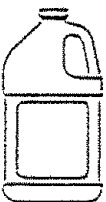
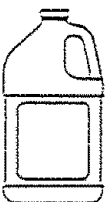
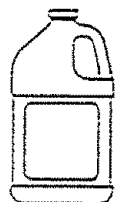
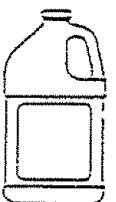
 <p>FLOOR/SIDING BRUSH KIT</p>	 <p>ROTATING BRUSH KIT</p>	 <p>UTILITY BRUSH KIT</p>	 <p>18" STAINLESS STEEL EXTENSION</p>	 <p>ELECTRIC TURBO NOZZLE</p>	 <p>ANGLE EXTENSION KIT</p>
 <p>1/4" I.D. 25 ft. EXTENSION HOSE</p>		 <p>3/8" I.D. 50 ft. EXTENSION HOSE</p>		 <p>CHEMICAL INJECTION FOAMER</p>	
 <p>HIGH PRESSURE HOSE QUICK CONNECT KIT</p>	 <p>ACCESSORY QUICK CONNECT</p>	 <p>ACCESSORY QUICK CONNECT STARTER KIT</p>	 <p>HIGH PRESSURE HOSE TO HOSE COUPLING</p>	 <p>GARDEN HOSE QUICK CONNECT WITH 2 ADAPTORS</p>	 <p>PRESSURE GAUGE</p>
 <p>TURBO HEAD 1800 PSI (max.)</p>	 <p>TURBO HEAD 2200 and 2500 PSI (max.)</p>	 <p>MULTI-PURPOSE/HOUSE WASH</p>	 <p>DECK WASH</p>	 <p>VEHICLE/BOAT WASH</p>	 <p>DEGREASER</p>

CONTENTS OF HARDWARE PACK

Parts packed separately in carton

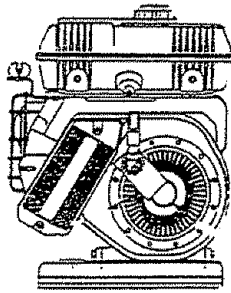

Main Unit

Parts Carton

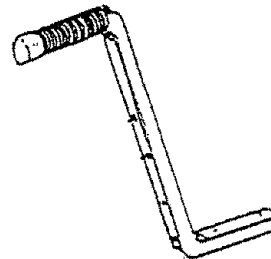
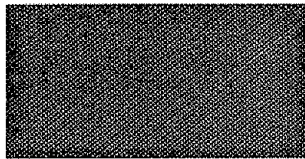

Guide Handle Assembly (packed in flat carton)

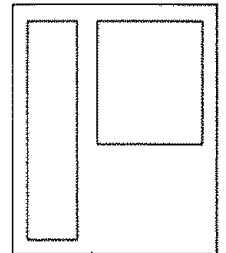

Owner's Manual

Parts packed in Parts Carton

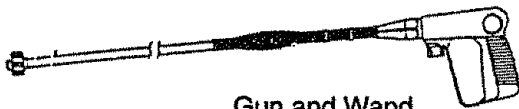

Gun and Wand



Detergent Pickup Tube and Filter

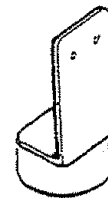

(2) Support Legs

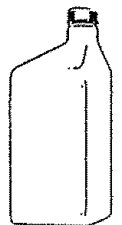

Motor Oil

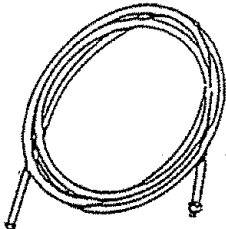

High Pressure Hose

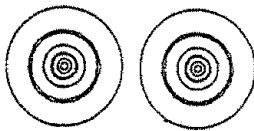

Wheels

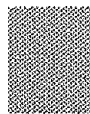

Nozzle Cleaner Kit

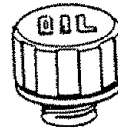

Oil Fill Cap/Breather



Vinyl Cap



Wire Support

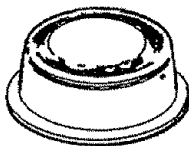

(2) Push Nuts - 1/2"



Quick-Connect

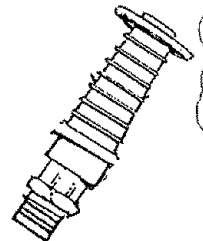

Adjustable Nozzle

Parts packed in carton shown full size

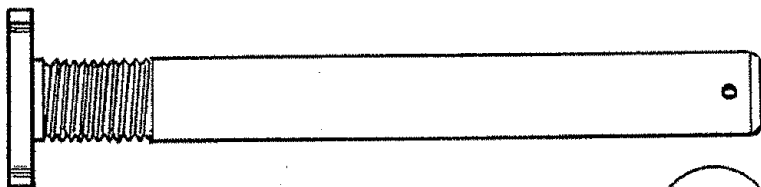

(2) Axle Pins

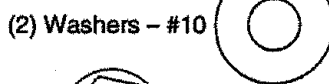

(2) Washers - #10

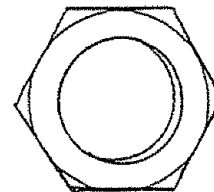

(2) JAM Nuts - 5/8"

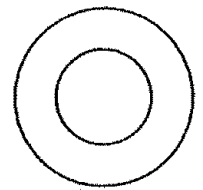

(2) Washers - M12



(2) Hex Head Capscrews - M8 x 40mm



(6) Flange Nuts - M8

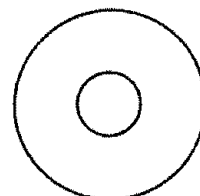

(2) Washers - M8

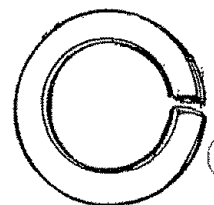

(2) Lock Washers - 5



(4) Hex Head Capscrews - M8 x 20mm

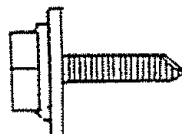

(2) Self-drilling Capscrews - #10-16

ASSEMBLY

Read these instructions and Operator's Manual in its entirety before you attempt to assemble or operate your new high pressure washer. Your high pressure washer has, for the most part, been assembled at the factory, except those parts left unassembled. Before you can operate your new high pressure washer, you must assemble the wheel kit and properly connect the high pressure hose.

IF YOU HAVE ANY PROBLEMS WITH THE ASSEMBLY OF YOUR PRESSURE WASHER, PLEASE CALL THE PRESSURE WASHER HELPLINE AT 1-800-222-3136.

TOOLS REQUIRED FOR ASSEMBLY

- Mallet
- 2 adjustable wrenches OR the following wrenches:
- 5/16" (8mm) combination wrench
- 1/2" (13mm) combination wrench
- 5/8" (16mm) combination wrench
- 11/16" (18mm) combination wrench
- 7/8" (22mm) combination wrench
- 15/16" (24mm) combination wrench

TO REMOVE PRESSURE WASHER FROM CARTON

- Remove two boxes marked "PARTS INSIDE" and remove the parts contained in both boxes.
- Remove unit with one hand under pump and one hand under recoil starter.

Refer to Page 6, "Contents of Hardware Pack" for an illustrated listing of all the items included with your pressure washer. Become familiar with each piece before assembling the pressure washer. Check all contents against the illustrations on Page 6. If any parts are missing or damaged, call the Pressure Washer Helpline at 1-800-222-3136.

HOW TO SET UP YOUR PRESSURE WASHER TO INSTALL THE WHEEL KIT

Installing the wheel kit requires the tools listed, the guide handle and items included in the parts carton.

- Prop up the engine end of the main unit. This will allow you to slip each axle pin into the holes provided on the side of the base (Fig. 1).

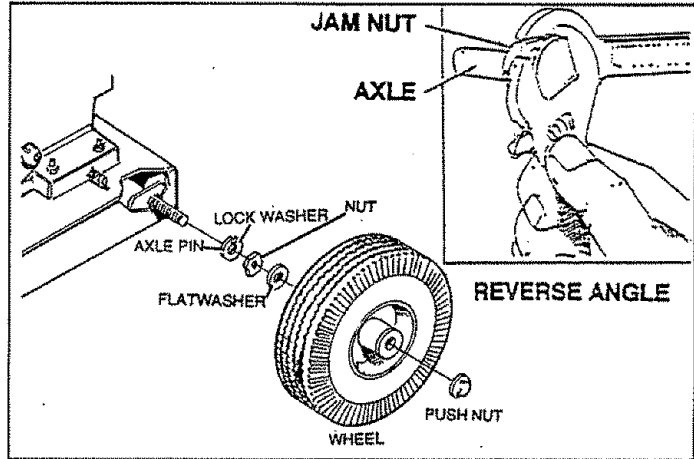

FIG. 1

- With the axle pin inserted inside the base, grip the end of the axle pin as shown with an adjustable or 15/16" combination wrench. This will keep the axle from spinning as you fasten the axle to the base with a 5/8" lock washer, a 5/8"-18 JAM nut, and an M12 flat washer.
- Place wheels on the axles so the valve side of hub is facing outward.
- Retain each wheel to its axle pin by tapping a push nut onto end of axle with a mallet.
- Attach support legs to base as shown in Fig. 2 with M8 x 20mm hex head capscrews and flange lock nuts. Tighten with 13mm or 1/2-inch wrench on each fastener. Be sure legs are straight when you are finished.
- Attach the guide handle to the base as shown in Fig. 2 with two M8 x 40mm hex head capscrews, two M8 washers and two flange nuts.

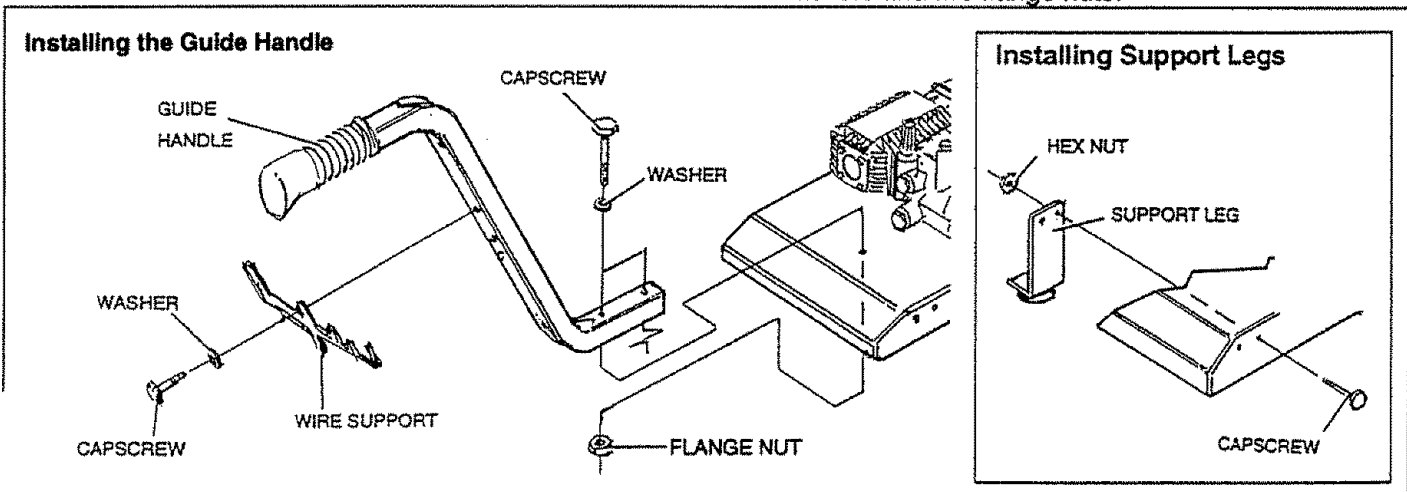

FIG. 2

ASSEMBLY

- Attach wire support to two lower holes in guide handle with #10 self-drilling screws and #10 flat washers (Fig. 3). The hose minder should be to the left and gun holder to the right. Be sure loop of support is pointing upward. Place vinyl cap onto gun holder.

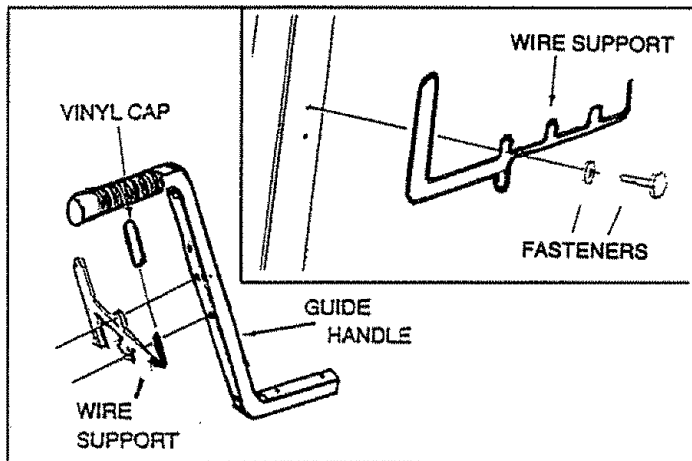

FIG. 3

TO ASSEMBLE REMAINING COMPONENTS

IMPORTANT: YOU MUST ASSEMBLE WAND AND ATTACH ALL HOSES BEFORE YOU START ENGINE. STARTING ENGINE WITHOUT ALL HOSES CONNECTED AND WATER SUPPLIED WILL DAMAGE PUMP.

- Remove cap from top of pump and insert oil fill cap attached to other end of yellow warning tag.

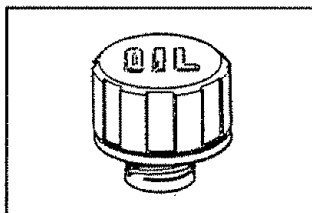

FIG. 4

- Included with this unit is a Quick-Connect fitting you attach to Water Inlet on pump. The quick-connect includes two parts — a Male Connector factory-installed on water inlet and a Female Connector (Fig. 5). Remove male connector to inspect Intake Supply

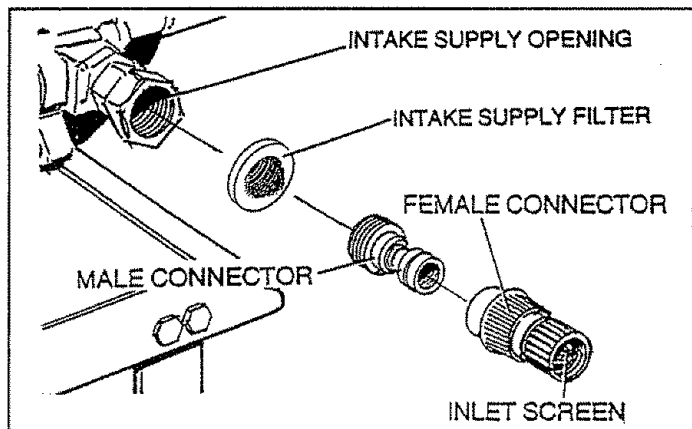

FIG. 5

Screen in water inlet for cleanliness and inspect Inlet Screen on female connector. Reattach male connector to water inlet and attach female connector to garden hose.

- Unravel high pressure hose, remove protective cap from end of hose and check other end of hose to see that threads are properly covered with teflon tape. If tape is not properly applied, reapply it so threads are fully covered. The tape seals the connection from hose to gun and wand assembly.
- Attach fitting with teflon tape to gun and wand assembly (Fig. 6). You may want to spin gun. Tighten with adjustable wrench to keep hose from twisting.

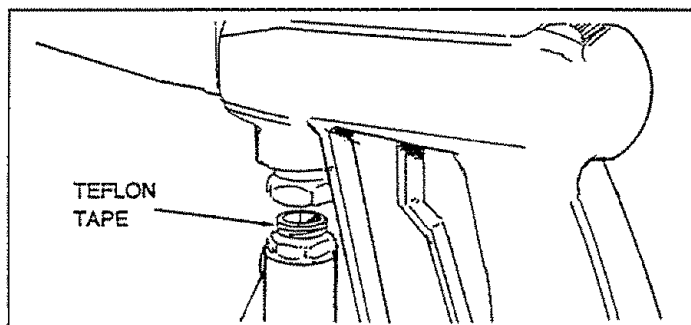

FIG. 6

- Attach the other end of the high pressure hose to high pressure fitting on pump (Fig. 7). Tighten with adjustable wrench.

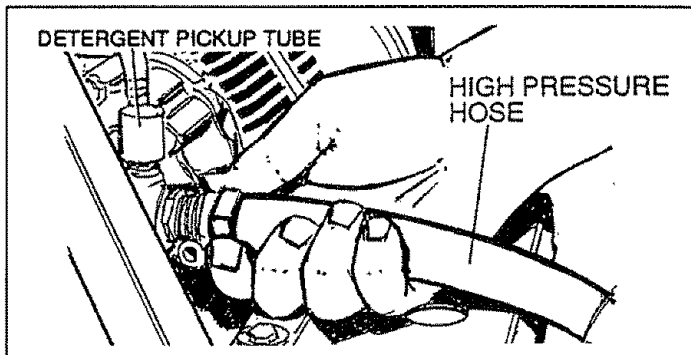

FIG. 7

- Attach Detergent Pickup Tube and Filter as shown in Fig. 7.
- To attach the adjustable nozzle, refer to Operation section, Fig. 9.

CHECKLIST

- Check that fasteners you used to install wheels and handle are tight. Vibration during operation may loosen fasteners that are not tight enough.
- Check for proper hose connections (high pressure and water supply) and for tight connections and that there are no kinks, cuts, or damage to the high pressure hose.
- Provide proper water supply (not to exceed 140°F).
- Be sure to read "Safety Rules" and "Operation" sections before using the pressure washer.

OPERATION

KNOW YOUR HIGH PRESSURE WASHER

READ THIS OWNER'S MANUAL AND SAFETY RULES BEFORE OPERATING YOUR HIGH PRESSURE WASHER. Compare the illustrations with your high pressure washer to familiarize yourself with the locations of various controls and adjustments. Save this manual for future reference.

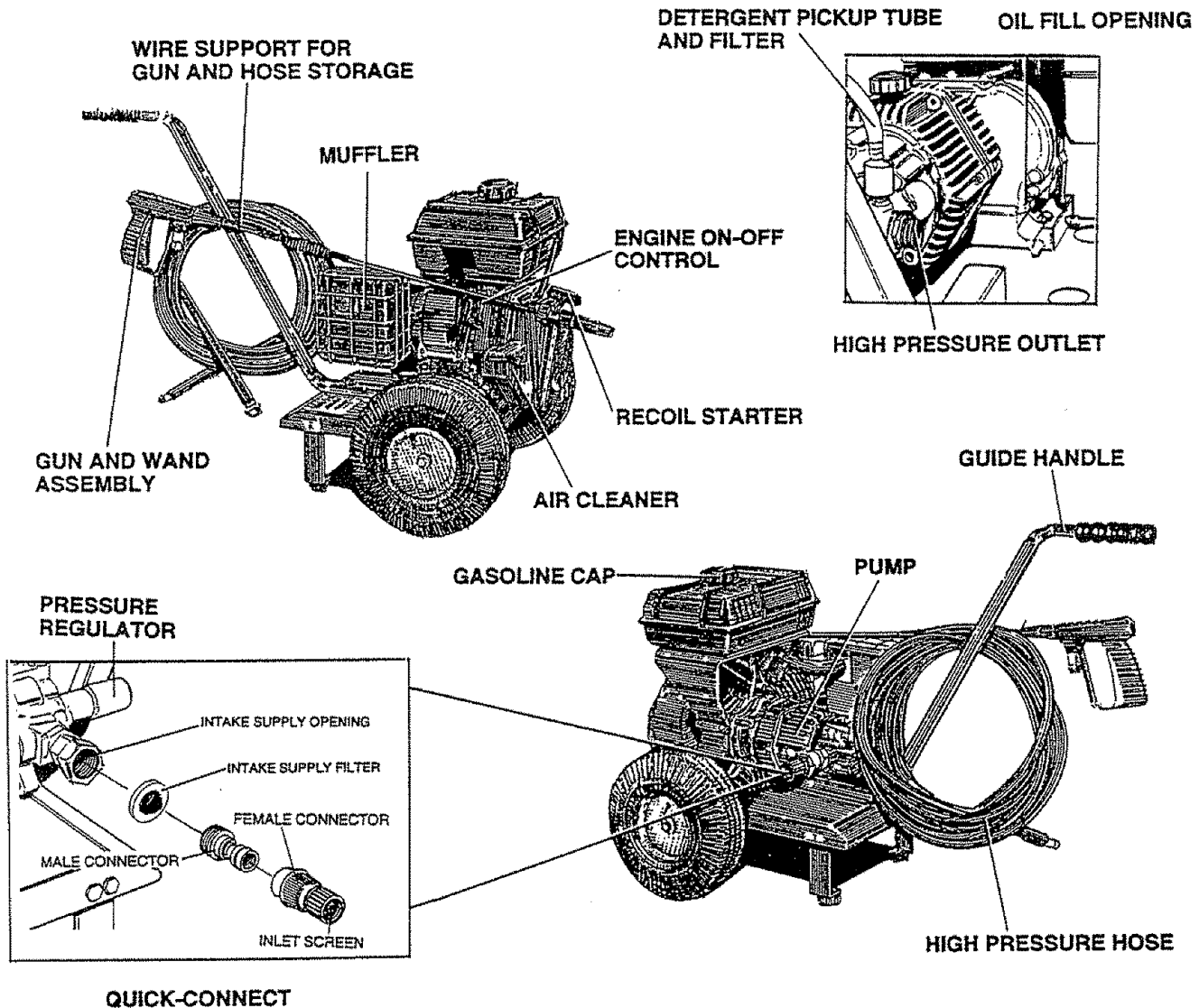

FIG. 8

PUMP — Develops high pressure.

PRESSURE REGULATOR — Allows you to adjust the pressure of the outlet stream.

ENGINE ON-OFF CONTROL — Sets engine in starting mode for recoil starter; turns OFF running engine.

RECOIL STARTER — Used for starting the engine manually.

AIR CLEANER - Dry type filter element limits the amount of dirt and dust that gets in the engine.

GUN AND WAND ASSEMBLY— Controls the application of water onto cleaning surface with trigger device. Includes safety latch.

INTAKE SUPPLY FILTER — Filters inlet water supply.

DETERGENT PICKUP TUBE AND FILTER — Mixes water and detergent in outlet water flow.

HIGH PRESSURE OUTLET — Connection for high pressure hose.

QUICK-CONNECT — Easy connection for intake water supply.

OPERATION

HOW TO USE YOUR WASHER

IF YOU HAVE ANY PROBLEMS OPERATING YOUR PRESSURE WASHER, PLEASE CALL THE PRESSURE WASHER HELPLINE AT 1-800-222-3136.

STOPPING YOUR PRESSURE WASHER

- First, move engine RUN/STOP switch to "STOP" position (Fig. 9).

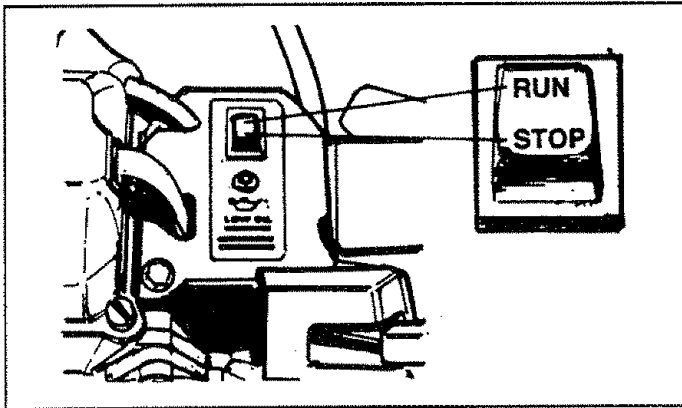

FIG. 9

- Simply shutting OFF engine will not release pressure in the system. Pull the trigger on the spray wand assembly to relieve the pressure in the hose.

NOTE: A small amount of water will squirt out when you release the pressure.

SPRAY NOZZLES

Your high pressure washer comes equipped with an adjustable nozzle (Fig. 10) or you can order the optional turbo nozzle (Fig. 11). Attach either nozzle as shown in Fig. 10 and **HAND TIGHTEN** the plastic knob.

HOW TO USE ADJUSTABLE NOZZLE

WARNING: NEVER ADJUST SPRAY PATTERN WHEN SPRAYING. NEVER PUT HANDS IN FRONT OF SPRAY NOZZLE TO ADJUST SPRAY PATTERN.

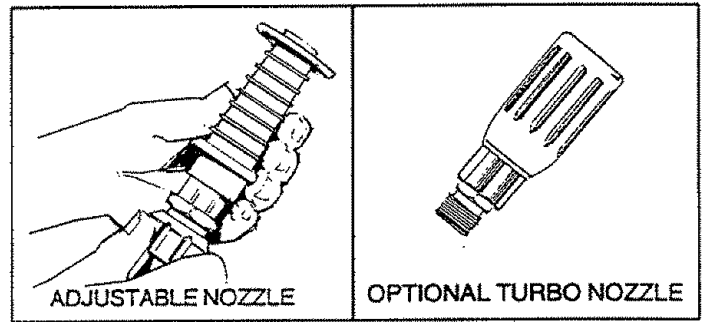

FIG. 10

FIG. 11

With the adjustable nozzle you can adjust the spray pattern to be either high pressure or low pressure. You can also adjust the spray so it is concentrated in a stream pattern or expanded into a fan pattern. Use this nozzle to apply detergent.

- Push the nozzle attachment forward when you wish to adjust the spray to low pressure mode (Fig. 12). Push the nozzle backward to achieve high pressure.
- Twisting the nozzle adjusts the spray pattern from a narrow stream to an expanded stream.

You can also adjust the pressure by turning the pressure control knob (Fig. 13) to the desired pressure setting. Turning this knob all the way clockwise produces the highest pressure. Do not unscrew the pressure control valve more than 3 turns. It will come off.

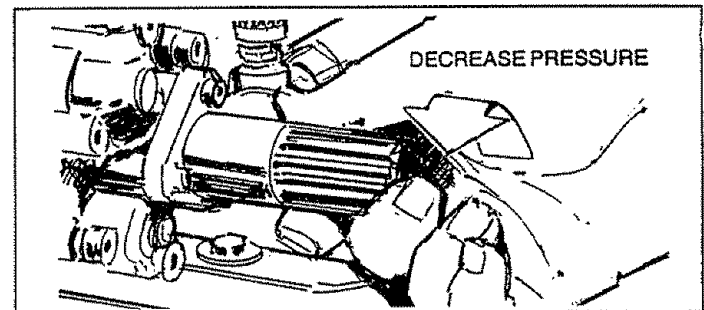

FIG. 13

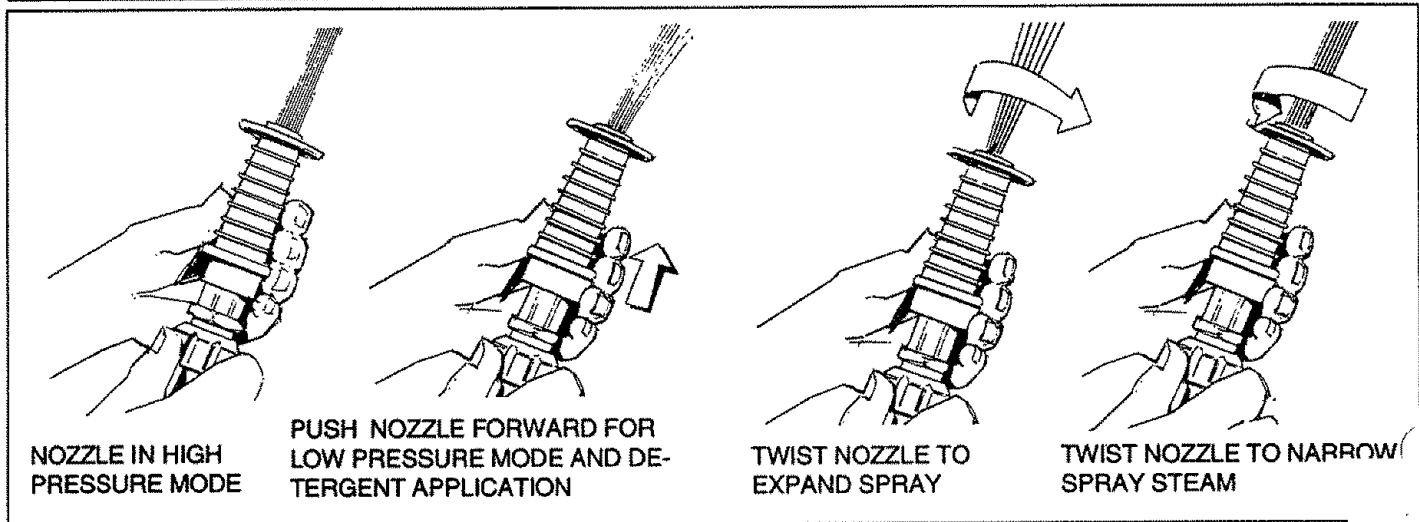

FIG. 12

OPERATION

APPLYING DETERGENT WITH ADJUSTABLE NOZZLE

IMPORTANT: USE SOAPS DESIGNED SPECIFICALLY FOR PRESSURE WASHERS. HOUSEHOLD DETERGENTS COULD DAMAGE THE PUMP.

IMPORTANT: YOU MUST ATTACH ALL HOSES BEFORE YOU START THE ENGINE. STARTING THE ENGINE WITHOUT ALL THE HOSES CONNECTED WILL DAMAGE THE PUMP.

Pressure washers are useful cleaning tools designed to clean almost any surface in two easy steps.

- The first step involves applying an appropriate detergent/solvent solution to penetrate and loosen grime. The detergent is applied at low pressure to avoid splashing, overspraying and waste. Leave the solution on surface for 3 to 5 minutes to allow solution to work.
- The second step involves cleaning the surface you have prepared with the pressure washer and then rinsing it clean.

To apply detergent follow these steps:

- Prepare your detergent solution as required by your job.
- Place small filter of the clear, detergent syphoning tube into the detergent container (Fig. 14).
Set nozzle to low pressure mode. Detergent is not siphoned in the high pressure mode (Fig. 12).

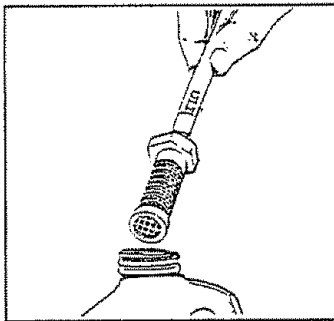

FIG. 14

- Start washer and apply detergent to a dry surface, starting from the bottom and working up.
- Adjust the concentration of detergent by turning the knob on the detergent injector (Fig. 15).
- To stop flow of detergent, turn knob clockwise, remove filter from detergent or set nozzle to high pressure.

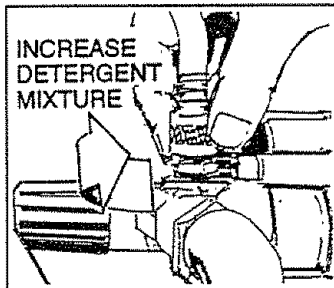

FIG. 15

NOTE: Detergents are most effective when applied to a dry surface.

PRESSURE WASHING/RINSING



WARNING: BE EXTREMELY CAREFUL IF YOU MUST USE PRESSURE WASHER FROM LADDER, SCAFFOLDING OR ANY OTHER RELATIVELY UNSTABLE LOCATION. PRESSURE IN A RUNNING WASHER BUILDS IN THE WAND AS YOU CLIMB. WHEN YOU PRESS THE TRIGGER, THE RECOIL FROM THE INITIAL SPRAY COULD FORCE YOU TO FALL, OR IF YOU ARE TOO CLOSE TO THE CLEANING SURFACE, HIGH PRESSURE COULD FORCE YOU OFF CLIMBING APPARATUS.

- Hook up water supply (Fig. 16) and turn ON water.
- **NOTE:** Be sure female quick-connect is installed properly onto male connector.

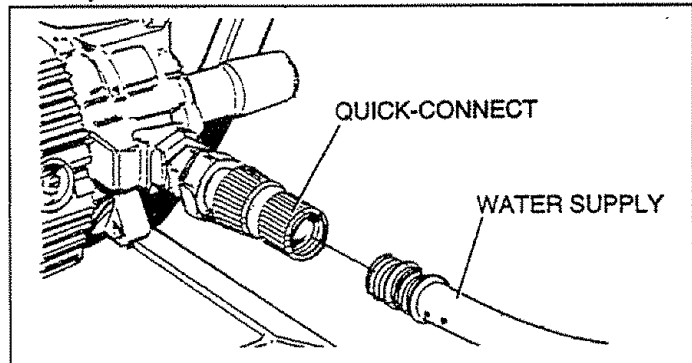

FIG. 16

- Adjust nozzle to select high pressure mode.
NOTE: Detergent will not flow when in the high pressure mode.
- Start washer and work from the top of the surface to the bottom.

NOTE: The high pressure mode is most effective when the tip of the wand is held between 8 inches to two feet from the surface being cleaned.

HOW TO USE OPTIONAL TURBO NOZZLE

- The optional rotating turbo nozzle, in essence, expands the area of the high pressure stream.
- You cannot adjust the spray pattern with this nozzle.
- You cannot apply detergent with this nozzle.

BEFORE STARTING THE ENGINE

To operate the engine you will need the following:

ENGINE OIL

IMPORTANT: ANY ATTEMPT TO CRANK OR START THE ENGINE BEFORE IT HAS BEEN PROPERLY SERVICED WITH THE RECOMMENDED OIL RESULTS IN AN ENGINE FAILURE.

A 20 oz. bottle of SAE 30 weight oil is included in the parts carton.

NOTE: When adding oil to the engine crankcase in the future, use only high quality detergent oil rated with API service classification SC, SD, SE, SF, SG rated SAE 30 weight. Use no special additives. Select the oil's viscosity grade according to your expected operating temperature.

colder	32°F	warmer
5W30		SAE30

Although multi-viscosity oils (5W30, 10W30, etc.) improve starting in cold weather, these multi-viscosity oils will result in increased oil consumption when used above 32°F. Check your engine oil level more frequently to avoid possible damage from running low on oil. Oil sump capacity is 20 ounces.

OPERATION

ADD ENGINE OIL:

- Place pressure washer on a level surface and remove one of the yellow Oil Fill Caps (Fig. 17) and add engine oil from the enclosed bottle until level is at point of overflowing. Check engine oil level before starting each time thereafter. If oil level is below point of overflowing, fill to proper level. Crankcase oil capacity is about 620ml or 21 fluid ounces.

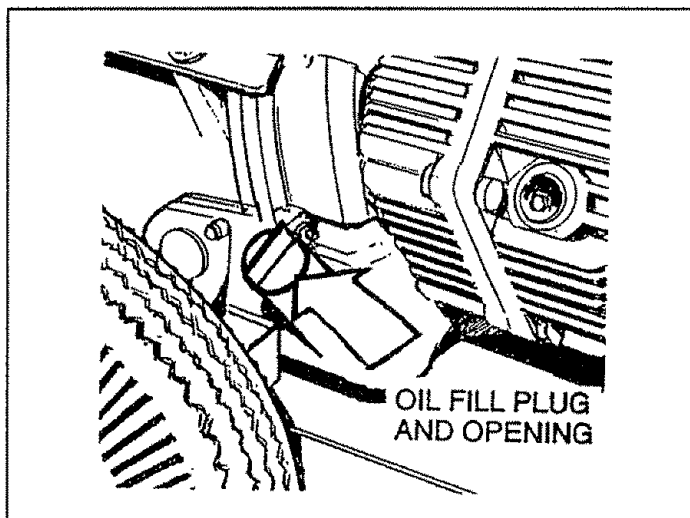

FIG. 17

CAUTION: ANY ATTEMPT TO CRANK OR START THE ENGINE BEFORE IT HAS BEEN PROPERLY SERVICED WITH THE RECOMMENDED OIL RESULTS IN AN ENGINE FAILURE.

ADD GASOLINE:

CAUTION: DO NOT OVERFILL THE FUEL TANK. ALWAYS ALLOW ROOM FOR FUEL EXPANSION.

WARNING: NEVER FILL FUEL TANK INDOORS. NEVER FILL FUEL TANK WHEN ENGINE IS RUNNING OR HOT. DO NOT LIGHT A CIGARETTE OR SMOKE WHEN FILLING FUEL TANK.

- Use regular UNLEADED gasoline with the pressure washer engine. Regular leaded gasoline may also be used if UNLEADED is not available. Fuel tank capacity is 1 U.S. gallon.

IMPORTANT: IT IS IMPORTANT TO PREVENT GUM DEPOSITS FROM FORMING IN ESSENTIAL FUEL SYSTEM PARTS SUCH AS THE CARBURETOR, FUEL FILTER, FUEL HOSE OR TANK DURING STORAGE. ALSO, EXPERIENCE INDICATES THAT ALCOHOL-BLENDED FUELS (CALLED GASOHOL OR USING ETHANOL OR METHANOL) CAN ATTRACT MOISTURE WHICH LEADS TO SEPARATION AND FORMATION OF ACIDS DURING STORAGE. ACIDIC GAS CAN DAMAGE THE FUEL SYSTEM OF AN ENGINE WHILE IN STORAGE. TO AVOID ENGINE PROBLEMS, THE FUEL SYSTEM SHOULD BE EMPTIED BEFORE STORAGE OF 30 DAYS OR LONGER. SEE "STORAGE" ON PAGE 18. NEVER USE ENGINE OR CARBURETOR CLEANER PRODUCTS IN THE FUEL TANK OR PERMANENT DAMAGE MAY OCCUR.

- Clean area around fuel fill cap, remove cap.
- Add "UNLEADED" regular gasoline, slowly, to fuel tank.
- Install fuel cap and wipe up any spilled gasoline.

TO TURN ON WASHER

- Attach one end of a garden hose to a cold water source. Water supply should not exceed 140°F (55°C).
- Check that high pressure hose is attached to pump outlet and that water supply is attached to pump inlet.
- Turn ON water.
- Press trigger on gun and wand assembly to force air from high pressure hose.
- Start engine according to "TO START THE ENGINE."

TO START THE ENGINE

IMPORTANT: DO NOT RUN PUMP WITHOUT THE WATER SUPPLY CONNECTED AND TURNED ON.

- Start, store and fuel the unit in a level position.
- Open fuel shut-off valve.
- Press trigger on pressure washer wand to relieve high pressure and/or purge the inlet hose of air.
- Adjust safety latch on spray gun to the ON position. This disables the trigger so you cannot inadvertently actuate a high pressure spray (Fig. 18).

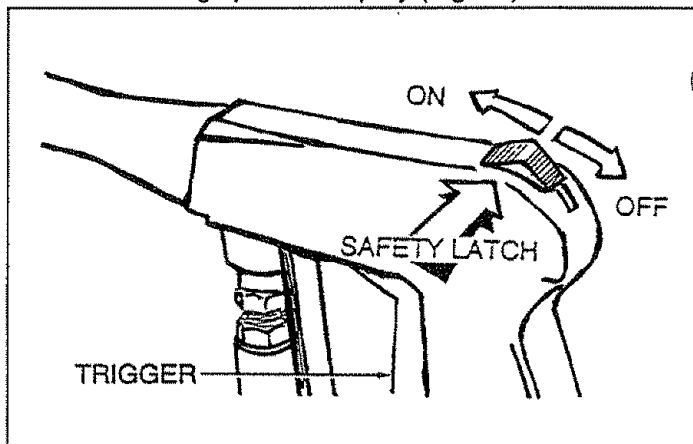

FIG. 18

- Locate the Run/Stop switch (Fig. 19 on Page 13) next to the engine cylinder head and set it to RUN.
- Close the choke to FULL position (Fig. 20 on Page 13) by sliding it to far position in direction indicated by arrow on air cleaner housing.
- Turn pressure control knob counterclockwise, two turns from maximum pressure.
- Grasp the starter grip and pull slowly until you feel resistance. Then pull rapidly.
- When engine starts, move choke lever to "RUN" position. If engine fails to start, move choke lever to "RUN" position and pull starter rope (maximum 2 pulls).
- If engine fails to start, repeat the previous two steps.

OPERATION

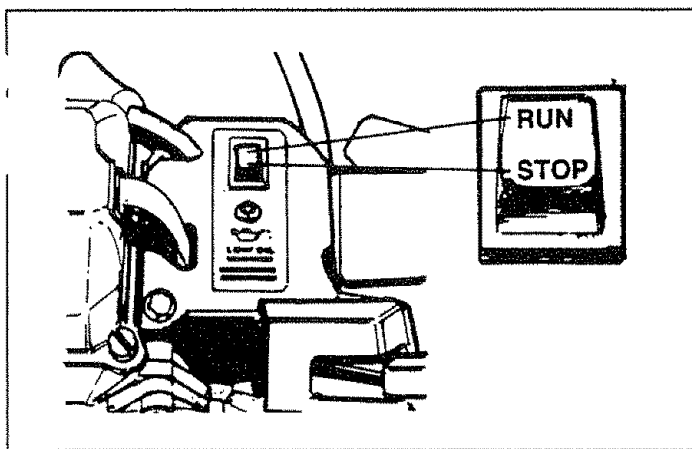

FIG. 19

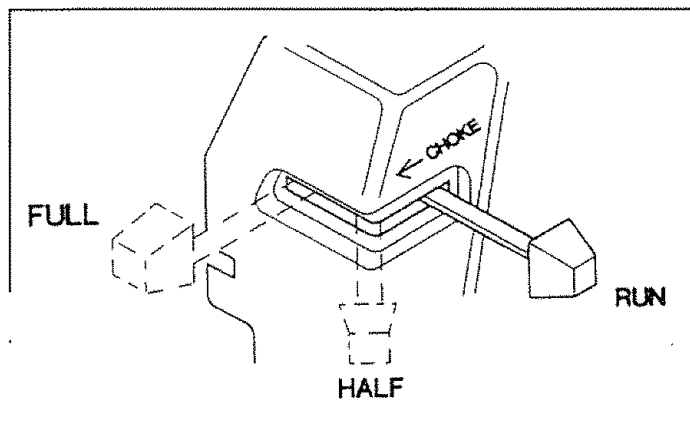

FIG. 20

- Once engine has started, place Safety Latch in OFF position.
- Press trigger on gun and wand assembly. Water should spray out the nozzle.
- Adjust nozzle for correct pressure and spray angle. You can also turn the pressure control knob to your desired pressure setting.
- Your pressure washer is ready to use.

IMPORTANT: AN INTERNAL THERMAL RELIEF VALVE HAS A MAXIMUM TEMPERATURE SETTING OF 140°F (60°C). IF YOU RUN THE PUMP FOR 5 MINUTES WITHOUT PRESSING THE TRIGGER ON THE SPRAY GUN, 1/2 TO 1 OUNCE OF WATER IS RELEASED THROUGH THE VALVE TO COOL THE UNIT. THE SMALL AMOUNT OF WATER WILL DRIP OUT THE BOTTOM OF PUMP.

LOW OIL PRESSURE SHUTDOWN SYSTEM

The engine is equipped with a low oil pressure sensor that shuts down the engine automatically when the oil pressure drops below 6 psi. If the engine shuts down by itself and the fuel tank has enough gasoline, check engine oil level.

TIAL STARTUP

delay built in the shutdown system allows oil pressure to build during starting. The delay allows the engine to run for about 10 seconds before sensing oil pressure.

SENSING LOW PRESSURE

If the system senses low oil pressure during operation, the engine shuts down. As the system shuts down, the low oil light comes ON. However, once the engine has stopped rotating, this light will go OFF. See Fig. 21 for schematic.

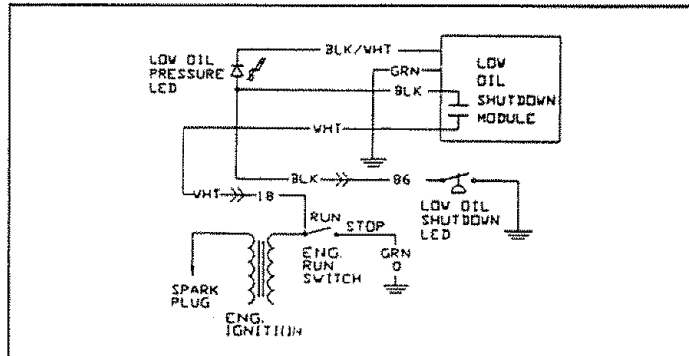

FIG. 21

RESTARTING

If you try to restart the engine within 10 seconds after it shuts down, the engine may NOT start. The system needs 5 to 10 seconds to reset.

If you do restart the engine after such a shutdown and have not corrected the low oil pressure, the engine runs for about 10 seconds as described above and then stops.

SIPHONING

We recommend that you DO NOT siphon your water supply. Connect only to household water supply.

TIPS

- Initially clean an area and then check the surface for damage. If no damage is found, you can assume it is okay to continue cleaning. Detergents work best when applied to dry surface.
- For most effective cleaning, keep spray nozzle between 8 to 24 inches of cleaning surface.
- Allow the detergent to soak in between 3-5 minutes before washing and rinsing.
- For cleaning, start at lower portion of area to be washed and work upward, using long, even overlapping strokes.
- For rinsing, push the nozzle sleeve to high pressure and wait for detergent to clear. Start at the top of area to be rinsed, working down with the same action as for cleaning.
- Never use the garden hose inlet to siphon detergent or wax.
- If you get the spray nozzle too close, especially using high pressure mode, you may damage the cleaning surface.
- If you have the spray nozzle too far away, the cleaning will not be as effective.
- Do not get closer than 6 inches when cleaning automobile tires.

CUSTOMER RESPONSIBILITIES

MAINTENANCE SCHEDULE FILL IN DATES AS YOU COMPLETE REGULAR SERVICE	HOURLY OPERATING INTERVAL				SERVICE DATES			
MAINTENANCE TASK	Before Each Use	Every 25 Hours or Yearly	Every 50 Hours or Yearly	Every 100 Hours or Yearly				
PRESSURE WASHER								
Check/clean inlet filter and screen	X [∇]							
Check high pressure hose.	X							
Check detergent hose.	X							
Check gun and wand for leaks.	X							
Check pump oil. ♦			X					
Purge pump of air and contaminants	X							
ENGINE								
Check oil level.	X							
Change engine oil. ♦			X*					
Retorque head bolts.			X					
Service air cleaner.		X**						
Clean/replace spark plug.				X				
Clean spark arrestor screen.				X				
Prepare for storage.	Prepare unit for storage if it is to remain idle longer than 30 days							

∇ Clean if clogged. Replace if perforated or torn. ♦ Change oil after first 8 hours, then after every 50 hours.

* Change sooner when operating under heavy load or high ambient temperature. ** Clean more often under dusty conditions or when airborne debris is present.

GENERAL RECOMMENDATIONS

The warranty of the high pressure washer does not cover items that have been subjected to operator abuse or negligence. To receive full value from the warranty, operator must maintain high pressure washer as instructed in this manual.

Some adjustments will need to be made periodically to properly maintain your high pressure washer.

All adjustments in the Service and Adjustments section of this manual should be made at least once each season.

- Once a year you should replace the spark plug and clean or replace the air filter and check the gun and wand assembly for wear. A new spark plug and clean air filter assure proper fuel-air mixture and help your engine run better and last longer.

BEFORE EACH USE

- Check engine oil level.
- Check water inlet filter and quick-connect screen for damage.
- Check high pressure hose for leaks.
- Check detergent inlet hose and filter for damage.
- Check gun and wand assembly for leaks.
- Purge pump of air and contaminants.

PRESSURE WASHER MAINTENANCE

Check and Clean Inlet Supply Filter and Inlet Screen: Remove quick-connect and examine inlet screen on the female connector and filter on pump inlet fitting. Clean if either is clogged or replace if either is torn.

Check High Pressure Hose: High pressure hose can develop leaks from wear, kinking, abuse. Inspect hose each time before using it. Check for cuts, leaks, abrasions or bulging of cover, or damage or movement of couplings. If any of these conditions exist, replace hose immediately.



DANGER: WATER SPRAYING FROM A LEAK IS CAPABLE OF INJECTING MATERIAL INTO SKIN. NEVER REPAIR HIGH PRESSURE HOSE. REPLACE WITH HOSE THAT MEETS MINIMUM PRESSURE RATING OF YOUR PRESSURE WASHER.

Check Detergent Hose: Examine the filter on the detergent hose and clean if clogged. Hose should fit tightly on barbed fitting. Examine hose for leaks or tears. Replace the filter or hose if either is damaged.

Check Gun and Wand: Examine hose connection to gun and make sure it is secure. Test trigger by pressing it and making sure it springs back into place when you release it. Put safety latch in ON position and test trigger. You should not be able to press trigger.

Check Pump Oil: Refer to PUMP MAINTENANCE for information.

CUSTOMER RESPONSIBILITIES

Purge Pump of Air and Contaminants:

To remove the air from the pump, follow these steps:

- Set up the pressure washer as described in the ASSEMBLY section and connect the water supply.
- Remove the nozzle attachment from the gun.
- Pull the trigger on the gun and hold.

To remove the contaminants from the pump, follow these steps:

- Set up the pressure washer as described in the ASSEMBLY section, connect the water supply and start the engine according to instructions in the OPERATION section.
- Remove the nozzle attachment from the gun.
- Pull the trigger on the gun and hold.
- When the water supply is steady and constant, you may refasten the nozzle attachment and start the pump.

PUMP MAINTENANCE

WARNING: DO NOT ATTEMPT TO DISASSEMBLE THE PUMP. WITHOUT THE PROPER TECHNIQUE, ATTEMPTING TO DISASSEMBLE PUMP MAY CAUSE PERSONAL INJURY. FOR SERVICE, CONSULT A SEARS AUTHORIZED SERVICE CENTER OR CONTACT YOUR PLACE OF PURCHASE.

Pump Oil: Change pump oil after first 50 hours of operation. Change pump oil every time you change the engine oil.

To change pump oil, follow these steps:

Place a proper container beneath the pump (Fig. 22).

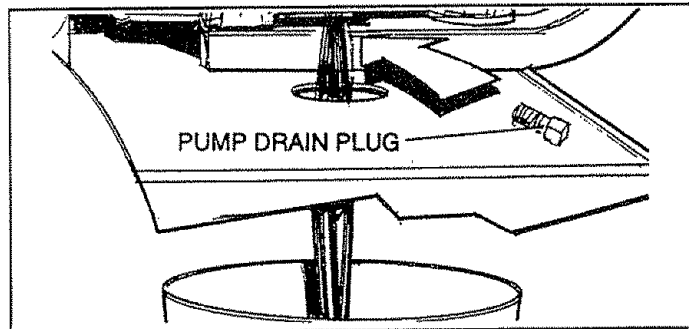

FIG. 22

- Remove the Oil Drain Plug of pump and drain oil into the container.
- When oil has drained completely, reinstall oil drain plug.
- Remove pump's oil fill plug, insert funnel and add recommended SAE 80W-90 oil until level reaches full mark on gauge located on side of the pump. Capacity is 5 ounces (150 grams).
- Reinstall the pump's oil fill plug.

ENGINE MAINTENANCE

CHECKING OIL LEVEL

Oil level should be checked prior to each use or at least every 5 hours of operation. Keep oil level maintained.

CHANGING ENGINE OIL

- Change oil after first 8 hours of operation. Change oil every 50 hours thereafter. If you are using your pressure washer under extremely dirty or dusty conditions, or in extremely hot weather, change oil more often.
- Change oil while engine is still warm from running, as follows:

CAUTION: DISCONNECT SPARK PLUG WIRE FROM SPARK PLUG AND KEEP IT AWAY FROM SPARK PLUG.

- Clean area around oil drain plug, remove plug and drain oil completely into a suitable container (Fig. 23).

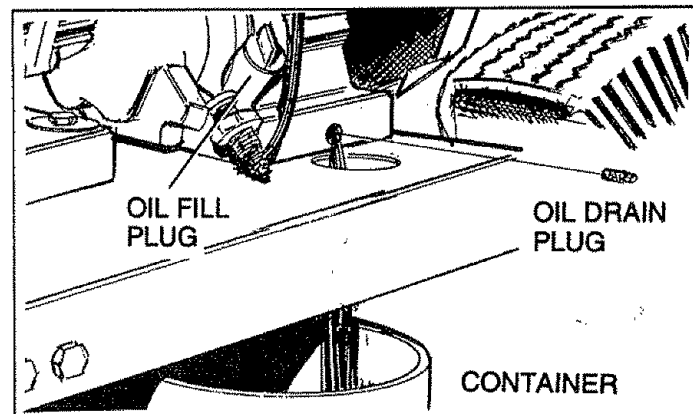

FIG. 23

- When oil has drained, install and tighten the oil drain plug.
- Remove yellow oil fill plug and insert a clean fill funnel into plug opening. Fill engine crankcase with recommended oil until oil level is at point of overflowing. Do not overfill above the point of overflowing. About 21 ounces (620ml) is required. POUR SLOWLY.
- When engine crankcase is filled to proper level. Install and tighten oil fill plug.

RETORQUE HEAD BOLTS

After 50 hours of operation, retorque the head bolts for this GN-Series engine to 4.0 kg/m (29 foot-pounds).

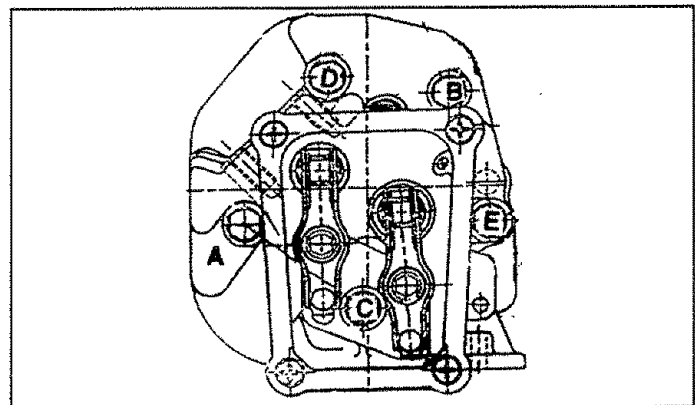

FIG. 24

The torque sequence is A, B, C, D, E (star pattern). See Fig 24.

CUSTOMER RESPONSIBILITIES

SERVICE AIR CLEANER



CAUTION: NEVER RUN THIS UNIT WITHOUT THE COMPLETE AIR CLEANER SYSTEM INSTALLED ON THE ENGINE. THIS COULD RESULT IN PREMATURE WEAR TO THE ENGINE.

Your engine will not run properly and may be damaged if you run it using a dirty air cleaner.

Clean or replace the air cleaner paper filter (Fig. 25) once every 25 hours of operation or once a year, whichever comes first. Clean or replace more often if operating under dusty or dirty conditions. Clean foam pre-filter every 25 hours of operation or sooner under dusty conditions.

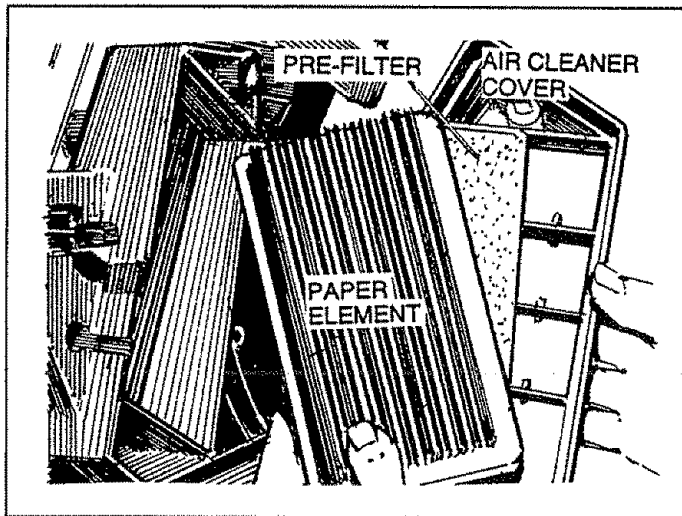

FIG. 25

To clean or replace foam pre-filter:

- Remove air cleaner cover, then foam pre-filter.
- Wash pre-filter in soap water. Squeeze pre-cleaner dry in clean cloth (DO NOT TWIST).
- Clean air cleaner cover before installing it.

To clean or replace paper air filter:

- Remove air cleaner cover; then remove foam pre-filter (service if necessary) and remove paper filter.
- Clean air filter by tapping it gently on a solid surface. If the filter is too dirty, replace it with a new one. Dispose of the old filter properly.
- Clean air cleaner cover then insert pre-filter into cover. Next insert new paper filter into cover to hold pre-filter in place and assemble all of them to the base of the air cleaner.

CLEAN/REPLACE SPARK PLUG

Change the spark plug every 100 hours of operation or once each year, whichever comes first. This will help your engine to start easier and run better. Replace with Champion RC12YC or equivalent type spark plug. Set spark plug gap 0.030 inch (0.76mm).

CLEAN SPARK ARRESTOR SCREEN

The engine exhaust muffler has a spark arrestor screen. Inspect and clean the screen every 100 hours of operation or once each year, whichever comes first.



WARNING: LET THE MUFFLER COOL BEFORE WORKING ON IT. CONTACT WITH A HOT MUFFLER OR ENGINE CAN CAUSE SEVERE BURNS.

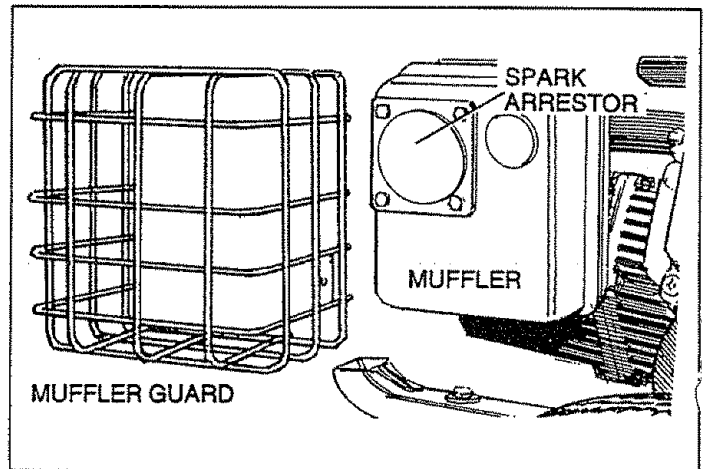

FIG. 26

NOTE: If you use your pressure washer on any forest-covered, brush-covered or grass-covered unimproved land, it must have a spark arrestor. The spark arrestor must be maintained in good condition by the owner/operator.

Clean and inspect the spark arrestor as follows:

- To remove the muffler guard from the muffler, remove the three screws that connect the guard to the muffler bracket (Fig. 26).
- Remove four screws that attach the spark arrestor screen.
- Inspect screen and replace if torn, perforated or otherwise damaged. DO NOT USE a defective screen. If screen is not damaged, clean it with commercial solvent.
- Reattach the screen and the muffler guard.

SERVICE AND ADJUSTMENTS

ENGINE SPEED



CAUTION: ENGINE SPEED WAS PROPERLY ADJUSTED AT THE FACTORY AND SHOULD REQUIRE NO ADDITIONAL ADJUSTMENT. DO NOT ATTEMPT TO CHANGE ENGINE SPEED. IF YOU BELIEVE THE ENGINE IS RUNNING TOO FAST OR TOO SLOW, TAKE YOUR PRESSURE WASHER TO SEARS AUTHORIZED SERVICE CENTER FOR REPAIR AND ADJUSTMENT. CHANGING ENGINE GOVERNED SPEED WILL VOID ENGINE WARRANTY.

Your pressure washer runs at a constant speed. This constant operating speed is maintained by a mechanical, flyweight type, fixed speed governor. DO NOT try to adjust the governed speed setting for the following reasons:

- High engine speeds are dangerous and increase the risk of personal injury or damage to equipment.

Low engine speeds impose a heavy load on the engine when sufficient engine power is not available and may shorten engine life.

ADJUSTING VALVE CLEARANCE

After the first 50 hours of operation, you should adjust the valve clearance in the engine.

When adjusting valve clearance, engine should be at room temperature and piston should be at Top Dead Center (TDC) of compression stroke (both valves closed). Correct clearance is 0.05-0.1mm. Adjust valve clearance as follows:

- Loosen the rocker arm jam nut. Use an allen wrench to turn the pivot ball stud while checking clearance between the rocker arm and the valve stem with a feeler gauge (Fig. 27).
- When valve clearance is correct, hold pivot ball stud with allen wrench and tighten rocker arm jam nut with crows foot. Tighten jam nut to 65-85 inch-pounds torque. After tightening jam nut, recheck valve clearance to make sure it did not change (Fig. 28).

NOZZLE MAINTENANCE

If the nozzle becomes restricted or clogged with foreign materials, such as dirt, excessive pump pressure may develop. A partially clogged nozzle can cause a pulsing sensation during use. This generally is not a pump related problem, but rather a clogged or partially restricted nozzle.

If the nozzle becomes clogged or partially restricted, immediately clean the nozzle with the kit included with your pressure washer by following these instructions:

- Shut off the engine and turn off the water supply.
- Separate the wand from the gun.
- Remove nozzle from the end of the wand using a 2mm or 5/64 allen wrench (like the one included in the kit).

Use the wire included in the kit (Fig. 29) or a small paper clip to free the foreign materials clogging or restricting the nozzle.

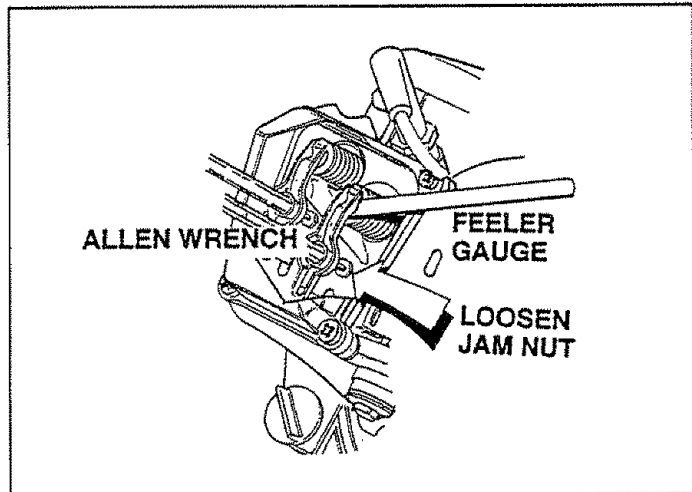

FIG. 27

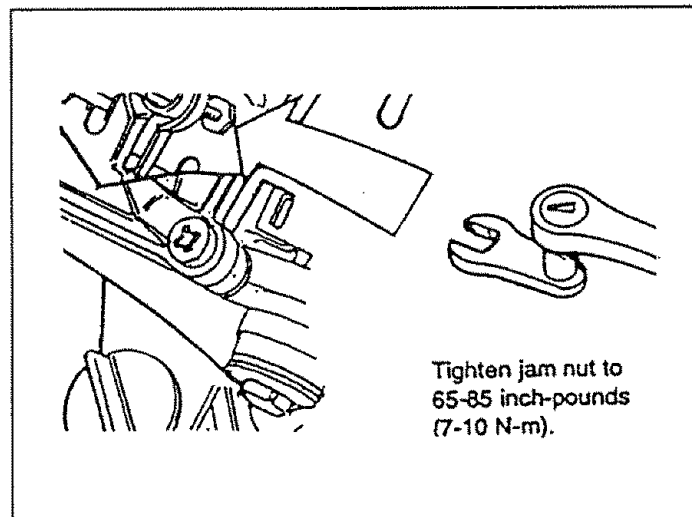

FIG. 28

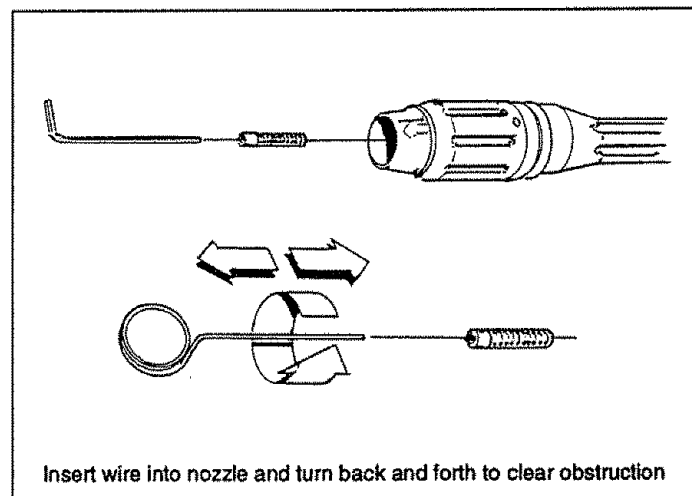

FIG. 29

SERVICE AND ADJUSTMENTS

- Remove additional debris by back flushing water supply through wand (Fig. 30). Back flush between 30 to 60 seconds. Turn wand to stream spray and move nozzle from low to high while flushing.
- Reinstall nozzle into the wand. DO NOT overtighten.
- Reconnect the wand to the gun
- Reconnect the water supply, turn on the water, and start the engine.

- Test the pressure washer by operating with nozzle in the high and in the low position.

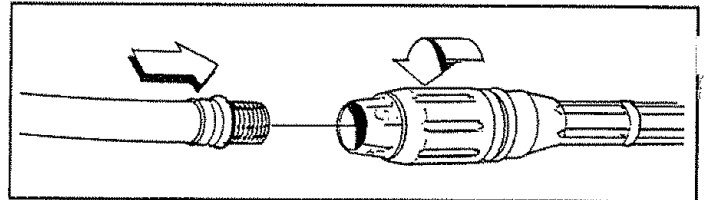

FIG. 30

STORAGE

AFTER EACH USE

Water should not remain in the unit for long periods of time. Sediments of minerals can deposit on pump parts and "freeze" pump action. Follow these procedures after every use:

- Flush detergent hose by placing the injector filter into a pail of clear water while running Pressure Washer with nozzle in low pressure mode. Flush until you can see clear water running through the tube.
- Shut off the engine and let it cool, then remove all hoses.



CAUTION: BE SURE THE THROTTLE LEVER IS IN "STOP" POSITION BEFORE YOU CONTINUE. IF YOU START THE ENGINE WITHOUT THE PROPER WATER SUPPLY CONNECTED, YOU CAN DAMAGE THE PUMP.

- Empty the pump of all pumped liquids by pulling recoil handle about 6 times. This should remove most of the liquid in the pump.
- Coil the high pressure hose and inspect it for damage. Cuts in the hose or fraying of it could result in leaks and loss of pressure. Should any damage be found, replace the hose. DO NOT attempt to repair a damaged hose and use it. Replace the hose with the genuine Craftsman part.
- Drain water from hose and properly hang it on the wire support provided on the guide handle.

NOTE: To protect the unit from freezing temperatures, you can draw windshield washer fluid into the pump by pouring the washer fluid into a 3-foot section of garden hose connected to the inlet adaptor and pulling the recoil handle twice.

- Store in a clean, dry area.

LONG TERM STORAGE



WARNING: NEVER STORE ENGINE WITH FUEL IN TANK INDOORS OR IN ENCLOSED, POORLY VENTILATED AREAS WHERE FUMES MAY REACH AN OPEN FLAME, SPARK OR PILOT LIGHT AS ON A FURNACE, WATER HEATER, CLOTHES DRYER OR OTHER GAS APPLIANCE.

If you do not plan to use the Pressure Washer for more than 30 days, you must prepare the engine for long term storage.

NOTE: As always, prepare the pressure washer pump as you would after each use.

It is important to prevent gum deposits from forming in essential fuel system parts such as the carburetor, fuel filter, fuel hose or tank during storage. Also, experience indicates that alcohol-blended fuels (called "gasohol" or using ethanol or methanol) can attract moisture which leads to separation and formation of acids during storage. Acidic gas can damage the fuel system of an engine while in storage.

To avoid engine problems, the fuel system should be emptied before storage of 30 days or longer. Follow these instructions:

Protect Fuel System: Engines stored over 30 days need to be protected or drained of fuel to prevent gum deposits from forming in fuel system or on essential carburetor parts.

- For engine protection use a fuel stabilizer. Mix stabilizer with fuel in fuel tank and run engine for short time to circulate stabilizer through carburetor.
- If you did use "gasohol", run engine until engine stops from lack of fuel. Make sure you have water supply to pump inlet connected and turned ON.

Change Oil: While engine is still warm, drain oil from crankcase. Refill with recommended grade.

Oil Cylinder Bore: Remove spark plug and pour about 1/2 ounce (15ml) of engine oil into the cylinder. Cover spark plug hole with rag. Crank slowly to distribute oil.



CAUTION! AVOID SPRAY FROM SPARK PLUG HOLE WHEN CRANKING ENGINE SLOWLY.

- Install spark plug. Do not connect spark plug wire.

OTHER

- Do not store gasoline from one season to another.
- Replace your gasoline can if your can starts to rust. Rust and/or dirt in your gasoline will cause problems.
- If possible, store your unit indoors and cover it to give protection from dust and dirt.
- Cover your unit with a suitable protective cover that does not retain moisture.

IMPORTANT: NEVER COVER YOUR PRESSURE WASHER WHILE ENGINE AND EXHAUST AREAS ARE WARM.

TROUBLESHOOTING

PROBLEM	CAUSE	CORRECTION
Pump has following problems: failure to produce pressure, erratic pressure, chattering, loss of pressure, low water volume.	<ol style="list-style-type: none"> 1. Nozzle in low pressure mode. 2. Low regulator pressure 3. Water inlet is blocked. 4. Inadequate water supply 5. Inlet hose is kinked or leaking 6. Clogged inlet hose strainer. 7. Detergent line is not submerged. 8. Water supply is over 140°F. 9. Outlet hose is blocked or leaks. 10. Gun leaks. 11. Nozzle is obstructed. 12. Pump is faulty. 	<ol style="list-style-type: none"> 1. Pull nozzle backward for high pressure mode. 2. Adjust regulator to desired setting. 3. Clear inlet 4. Provide adequate water flow. 5. Straighten inlet hose, patch leak. 6. Check and clean inlet hose strainer. 7. Submerge detergent line. 8. Provide cooler water supply. 9. Clear blocks in outlet hose. 10. Replace gun. 11. Clear nozzle. 12. Contact Sears Service Department.
Detergent fails to mix with spray.	<ol style="list-style-type: none"> 1. Detergent line is not submerged. 2. Chemical filter is clogged. 3. Nozzle is in high pressure mode. 4. Chemical adjuster is closed. 	<ol style="list-style-type: none"> 1. Insert chemical line into detergent. 2. Clean or replace filter/detergent line. 3. Push nozzle forward for low pressure mode. 4. Open chemical adjuster.
Engine runs good at no-load but "bogs"	Engine speed is too slow.	Contact Sears Service Department.
Engine will not start; or starts and runs rough	<ol style="list-style-type: none"> 1. Low oil level 2. Dirty air cleaner 3. Out of gasoline. 4. Stale gasoline. 5. Spark plug wire not connected to spark plug 6. Bad spark plug. 7. Water in gasoline. 8. Overchoking. 9. Excessively rich fuel mixture. 10. Intake valve stuck open or closed. 11. Engine has lost compression. 	<ol style="list-style-type: none"> 1. Fill crankcase to proper level. 2. Clean or replace air cleaner. 3. Fill fuel tank. 4. Drain gas tank; fill with fresh fuel. 5. Connect wire to spark plug. 6. Replace spark plug. 7. Drain gas tank; fill with fresh fuel. 8. Open choke fully and crank engine. 9. Contact Sears Service Department. 10. Contact Sears Service Department. 11. Contact Sears Service Department.
Engine shuts down during operation	<ol style="list-style-type: none"> 1. Out of gasoline. 2. Low oil level. 	<ol style="list-style-type: none"> 1. Fill fuel tank. 2. Fill crankcase to proper level.
Engine lacks power.	Dirty air filter.	Replace air filter.
Engine "hunts" or falters.	Choke is opened too soon.	Move choke to halfway position until engine runs smoothly.



ITEM	PART NO.	DESCRIPTION	ITEM	PART NO.	DESCRIPTION
1	90507	6.5 HP Engine with 70mm piston (1 req.)	37	77584	Handle Grip (1 req.)
2	95319C	3.0 Gpm Pump (1 req.)	38	96168	Chemical Injector Hose (1 req.)
3	95456	Quick-connect, Male (1 req.)	39	95587A	Adjustable Nozzle (1 req.)
4	96016	Quick-connect, Female (1 req.)	40	91630	3/8" x 25 Ft. Hose Assembly (1 req.)
5	94944	Piston Pivot Shoe (3 req.)	41	95567	Gun And Wand Assembly (1 req.)
6	93790	O-ring, 2.6 x 114 (1 req.)	44	94197	Pressure Gauge [optional] (1 req.)
7	96542	Rolling Thrust Bearing (1 req.)	45	65852	Spring Clip (1 req.)
8	96865	8mm Axial Cam (1 req.)	46	95214	Cradle (1 req.)
9	95165	Engine Adaptor Shaft (1 req.)	47	96002	Tank Bushing (4 req.)
10	93873	M6 Ribbed Lock Washer (6 req.)	48	96001	M6-1.0 x 21mm Bolt (4req.)
11	95963	Front Gun Bracket (1 req.)	49	95963	Front Gun Bracket (1 req.)
12	93869	Ball Thrust Bearing (1 req.)	50	90878	Fuel Cap (1 req.)
13	23707	5/16"-24 x 1" Bolt (4 req.)	51	45764	M4-0.7 x 8mm Taprite Screw (3 req.)
14	96430A	Engine Adaptor (1 req.)	52	77395	M6-1.0 Locking Nut (2 req.)
15	93871	Engine Adaptor Gasket (1 req.)	53	96193	Fuel Shut-off Valve (1 req.)
16	92479	M8 Ribbed Lock Washer (4 req.)	54	48031C	Hose Clamp (4 req.)
17	40945	M6-1.0 x 20mm Capscrew (4 req.)	55	30340	1/4" I.D. Fuel Hose (1 req.)
18	39414	M8-1.25 x 35mm Capscrew (4 req.)	56	90300	Muffler Support Bracket (1 req.)
19	96963	Mounting Base (1 req.)	57	90299	M5 x 10mm Screw (11 req.)
20	75402	1/2" Dia. Push Nut (2 req.)	59	92535	Muffler Support Bracket (1 req.)
21	88521	2-1/4" x 4" Wheel (2 req.)	60	40976	M8 x 20mm Screw (2 req.)
22	49808	M12 Flat Washer (2 req.)	61	89476	Exhaust Gasket (1 req.)
23	25391	Jam Nut (2 req.)	62	89712	Muffler Guard (1 req.)
24	93728A	Axle Pin (2 req.)	63	83083	Spark Arrestor Screen (1 req.)
25	39253	M8-1.25 x 20mm Capscrew (6 req.)	64	88688	Muffler Assembly (1 req.)
26	52858	M8-1.25 Flange Nut (12 req.)	65	83512	M8-1.25 x 15mm Screw (2 req.)
27	22246	5/8" Lock Washer (2 req.)	67	93887	M16 x 1.5 Jam Nut (1 req.)
28	92339	Support Leg (2 req.)	68	94738	Bellville Washer (1 req.)
29	87841	Shock Mount (2 req.)	69	94994	Fuel Tank (1 req.)
30	57821	M8-1.25 x 40mm Screw (2 req.)	70	95454	Oil Cap/breather (1 req.)
31	50190	M8 x 25 Flat Washer (2 req.)	72	40945	M6-1.0 x 20mm Capscrew (3 req.)
32	91093	Guide Handle (1 req.)	73	93873	M6 Ribbed Lock Washer (3 req.)
33	92067	Vinyl Cap (1 req.)	74	96581E	Unloader Assembly (1 req.)
34	95908	Gun And Hose Holder (1 req.)	75	93723	Spindle Seat "O" Ring (1 req.)
35	96633	5mm x 20mm Flat Washer (2 req.)	76	92661	Nozzle [mv Blue] (1 req.)
36	86292	#10 Self-drilling Screw (2 req.)	77	51767	M6 x 1 x 45mm Capscrew (2 req.)
			78	95441	SLEEVE, ENGINE ADAPTOR (1 req.)

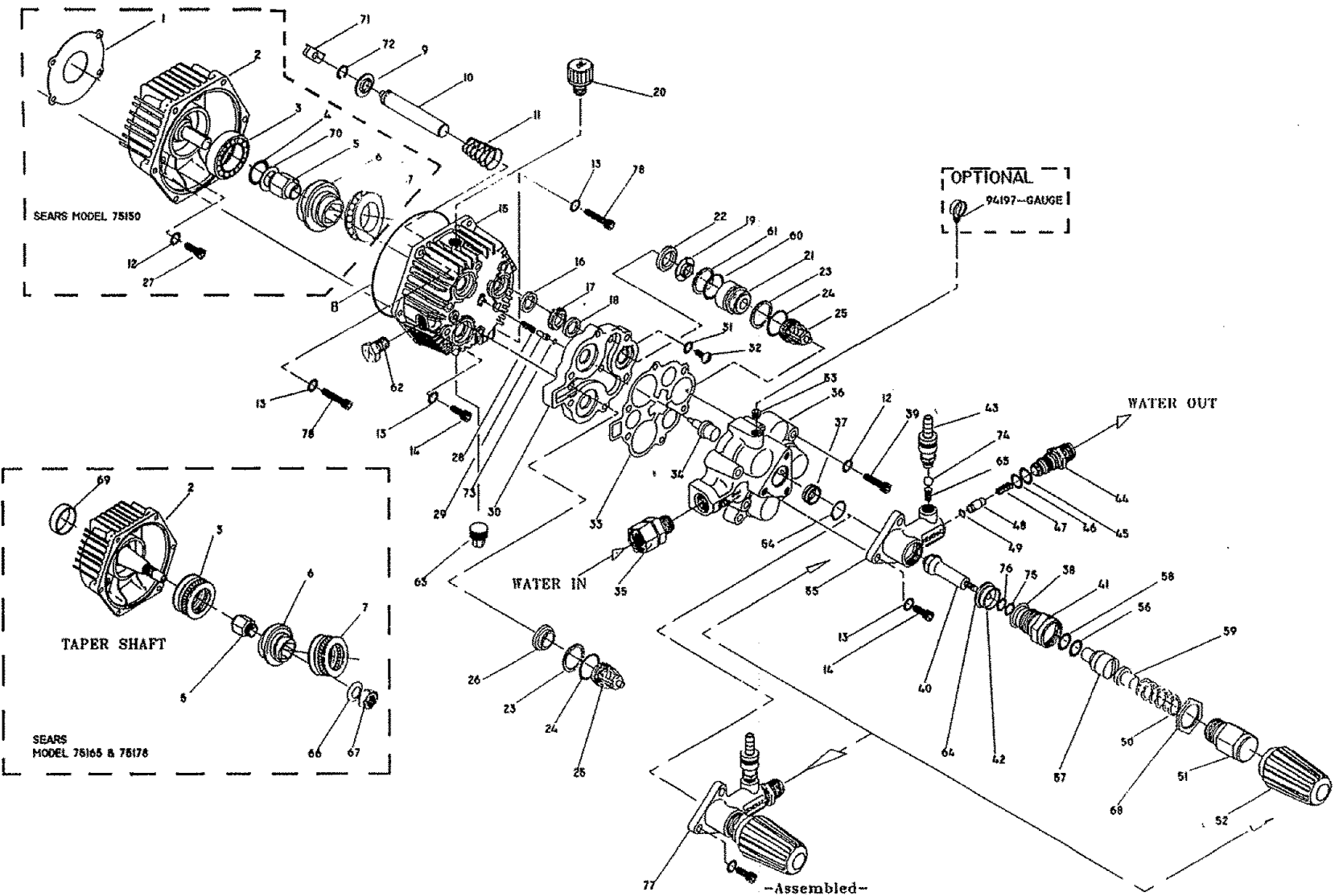

CRAFTSMAN 2200 PSI HIGH PRESSURE WASHER 580.751651

REPAIR PARTS

ITEM	PART NO.	DESCRIPTION	ITEM	PART NO.	DESCRIPTION
1	93871	Engine Adaptor Gasket (1 req.)	40	95373	Unloader Assembly Spindle (1 req.)
2	96430-A	Engine Adaptor (1 req.)	41	95367	Unloader Piston Guide (1 req.)
3	93869	Thrust Ball Bearing (1 req.)	42	95372	O-ring 1.78 x 14mm (1 req.)
5	95165	Engine Adaptor (1 req.)	43	95378	Chemical Injector Fitting (1 req.)
6	96865	Axial Cam (1 req.)	44	95377	High Pressure Outlet Adaptor (1 req.)
7	96542	Thrust Roller Bearing (1 req.)	45	93788	O-ring 1.78 x 12.4mm (1 req.)
8	93790	114 x 119 x 2.6 O-ring (1 req.)	46	93787	O-ring 1.78 x 15.6mm (1 req.)
9	95386	Piston Spring Retainer (3 req.)	47	95376	Spring (1 req.)
10	95217	Piston, D15 S.S. (3 req.)	48	95374	High Pressure Outlet Piston (1 req.)
11	96400	Piston Return Spring (3 req.)	49	95375	O-ring, #2.4 x 4.3 (1 req.)
12	92479	M8 Ribbed Lock Washer (10 req.)	50	95384	Pressure Adjust Spring (1 req.)
13	93873	M6 Ribbed Lock Washer (9 req.)	51	95364-B	Pressure Adjust Adaptor with groove (1 req.)
14	40945	M6 x 1.0 x 20mm Capscrew (7 req.)	52	95381-B	Pressure Adjust Handle [red] (1 req.)
15	94404	Aluminun Crankcase (1 req.)	53	96137	1/8" NPT Pipe Plug (1 req.)
16	93680	Piston Oil Seal (3 req.)	54	93723	"O" Ring 2.6 x 20.2 (1 req.)
17	93668	Pilot Spacer (3 req.)	55	95216	Pressure Relief Valve Body (1 req.)
18	93667	Seal (3 req.)	56	95369	Back-up O-ring 11 x 12.4 (1 req.)
19	96015	Bearing Ring Seal (3 req.)	57	95368	Unloader Piston (1 req.)
20	95454	Oil Fill/Breather (1 req.)	58	95370	O-ring 1.78 x 7.65 (1 req.)
21	95895	High Pressure Port Tower (3 req.)	59	95363	Spring Support (1 req.)
22	96053	High Pressure Seal [black] (3 req.)	60	96069	Quad-Ring 0.09 x 1.06" (3 req.)
23	95504	Back-up Ring (1 req.)	61	95506	Back-up Ring (3 req.)
24	95503	O-Ring 2.62 x 17.12mm (6 req.)	62	95453	Sight Gauge Assembly
25	96005	Valve Check Kit (6 req.)	63	57163	3/8" NPT Magnetic Plug (1 req.)
26	95896	Check Valve Seat Support (3 req.)	64	95371	Piston Support O-ring (1 req.)
27	23707	5/16"-24 x 1" Bolt (4 req.)	65	95380	Chemical Injector Spring (1 req.)
28	93652	Thermal By-pass Spring (1 req.)	66	94738	Belleville Washer (1 req.)
29	95416	By-pass Piston (1 req.)	67	93887	M16-1.6 JAM Nut (1 req.)
30	94402	Spacer Plate (1 req.)	68	95366	M18 x 1.0 Nut (1 req.)
31	93673	O-ring 4.5 x 8 x 1.8 (2 req.)	69	95441	Engine Adaptor Sleeve (1 req.)
32	93678	M5-0.8 x 20 Truss Head Bolt (2 req.)	71	94944	Piston Pivot Shoe (3 req.)
33	93645	Head Gasket (1 req.)	72	94284	"C" Ring Retainer (3 req.)
34	93644	Thermal By-pass Actuator (1 req.)	73	93876	O-Ring, 0.12 x 0.25 x 0.6 (1 req.)
35	95320	Garden Hose Connector (1 req.)	74	95379	Ball (1 req.)
36	95138	Cylinder Head (1 req.)	75	93656	O-Ring 1.78 x 6.07 (1 req.)
37	95382	Spindle Seat (1 req.)	76	93657	Back-up Ring 1.24 x 6.7 (1 req.)
38	93722	O-Ring, 0.68 X 0.81 x 0.06 (2 req.)	77	95212-B	Unloader Assembly (1 req.)
39	93874	M8-1.25 x 75mm Capscrew (6 req.)	78	51767	M6-1.0 x 45mm Capscrew (2 req.)



ITEM	PART NO.	DESCRIPTION	ITEM	PART NO.	QTY.	DESCRIPTION
1	90507	Engine, Taper Shaft used with 70mm piston (1 req.)	31	78607		Air Cleaner Base (1 req.)
2	77182T	Flywheel Assembly used with 70mm piston (1 req.)	32	78651C		Blower Housing Back Plate (1 req.)
3	81675	Ignition Coil Assembly (1 req.)	33	92984		Top Wrapper (1 req.)
4	81810	M16-1.5 Hex Nut (1 req.)	34	80303		Breather Canal Cover (1 req.)
5	83312	Conical Washer (1 req.)	35	72347		RC-12YC Spark Plug [Champion] (1 req.)
6	90695A	Blower Housing (1 req.)	36	45756		M6-1.0 x 10mm Bolt (5 req.)
7	95948	Carburetor Assembly (1 req.)	37	66476		M6-1.0 x 12mm Capscrew (11 req.) with lock washer (2 req.)
8	78631	Carb./Manifold Gasket (1 req.)	38	80316		M6-1.0 x 30mm Capscrew with lock washer (1 req.)
9	90948	HS Intake Manifold (1 req.)	39	59635		No. 8 x 3/8" Plastite Screw (1 req.)
10	78608A	Air Cleaner Cover (1 req.)	40	83504		Choke Lever Knob (1 req.)
11	78601	Air Filter Element (1 req.)	43	82981		M6-1.0 x 30mm Taptite Bolt (2 req.)
12	78602	Air Filter Pre-Cleaner (1 req.)	44	78653		Shut-off Switch (1 req.)
13	83015	Recoil Cup (1 req.)	45	49813		M6-1.0 Hex Nut (2 req.)
14	81671	Recoil Assembly (1 req.)	46	22097		M6 Lock Washer (1 req.)
15	90051	Manifold/Head Gasket (1 req.)	47	83512		M8 x 15mm Taptite Bolt (1 req.)
16	91846	Carburetor/Air Cleaner Gasket (1 req.)	48	85272		Low Oil Indicator LED (1 req.)
17	78609	Bolt - Air Cleaner Cover (2 req.)	49	77667		4 psi Oil Pressure Switch (1 req.)
18	90947	Breather Hose (1 req.)	51	84195		LOS Engine Decal (1 req.)
19	82774	4 x 19 Woodruff Key (1 req.)	56	85953		Carburetor Wear Washer (1 req.)
20	86962	Governor Lever Ass (1 req.)	57	91848		Oil Filter Pad Gasket (1 req.)
21	78604	Governor Spring (1 req.)	58	92978		M6-1.0 x 20mm Screw (2 req.)
22	83502	Governor Adjusting Screw (1 req.)	61	87221A		LOS Module [optional] (1 req.)
24	83782	Idle Control Coil (1 req.)	62	88758		By-pass Adaptor [optional] (1 req.)
25	86037	Anti-Lash Extension Spring (1 req.)	64	94820		Expansion Plug (1 req.)
26	86384	Governor Rod (1 req.)	68	66311		JAM-M8-1.25 Hex Nut (1 req.)
27	83781	Gov. Adjust Bracket (1 req.)	69	49811		M6-12.5 O.D. Flat Washer (1 req.)
28	78643	Carburetor Mtng. Bolt (2 req.)	70	95213		Fuel Tank Bracket (1 req.)
29	83503	M5-0.8 Lock Nut (1 req.)				
30	89739	Bottom Wrapper (1 req.)				



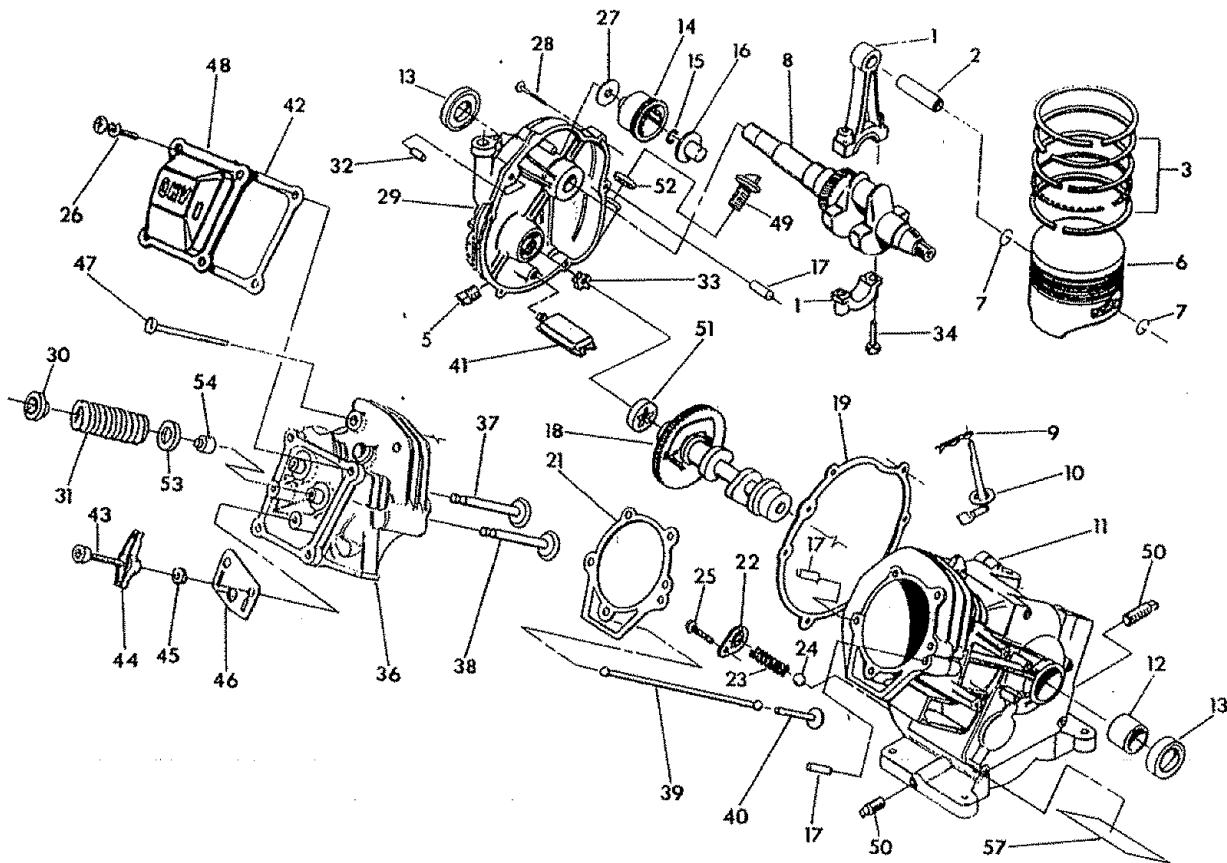

ITEM	PART NO.	DESCRIPTION	ITEM	PART NO.	DESCRIPTION
1	76380	Connecting Rod with Cap (1 req.)	29	88420A	Sub-assembly Gear Cover (1 req.)
2	76389	Piston Pin (1 req.)	30	86293	Valve Spring Retainer (2 req.)
3	78660	70mm Piston Ring Set (1 req.)	31	88401	Valve Spring (2 req.)
5	72683	1/8" NPT Pipe Plug (1 req.)	32	88590	12mm dia. x 20mm Dowel Pin (1 req.)
6	90325	70mm Piston (1 req.)	33	83152	Inner Gerotor (1 req.)
7	76390	Piston Pin Retainer (2 req.)	34	76381	Connecting Rod Bolt (2 req.)
8	83337	Crankshaft Assm. w/gear (1 req.)	35	78659	Governor Arm Washer (1 req.)
9	78658	Governor Arm "R" Pin (1 req.)	36	88404B	Cylinder Head with Valve Seats and Guides (1 req.)
10	76354	Governor Arm (1 req.)	37	90082	Exhaust Valve (1 req.)
11	89213B	Crankcase Sub-assy. [70mm](1 req.)	38	90081	Intake Valve (1 req.)
12	76349	Sleeve Bearing (1 req.)	39	88396A	Push Rod (2 req.)
13	81695	Crankshaft Seal (2 req.)	40	83235	Tappet (2 req.)
14	76359	Governor Gear Assembly (1 req.)	41	80336	Oil Pickup Assembly (1 req.)
15	78645	Governor Retainer ["C" Ring] (1 req.)	42	88397	Rocker Cover Gasket (1 req.)
16	76365	Governor Spool (1 req.)	43	77161	Pivot Ball Stud (2 req.)
17	78699B	Sleeve Dowel [12mm Dia.] (3 req.)	44	77160	Rocker Arm (2 req.)
18	83335	Camshaft Assembly (1 req.)	45	76307	Jam Nut [rocker Arm] (2 req.)
19	89096	Crankcase Gasket (1 req.)	46	88403	Push Rod Guide Plate (1 req.)
21	88058	Cylinder Head Gasket (1 req.)	47	77168	M8 x 52mm Head Bolt (5 req.)
22	78691	Oil Pressure Sprg Retainer (1 req.)	48	88412	Rocker Cover Assm. (1 req.)
23	76367	Oil Pressure Spring (1 req.)	49	76329	Oil Fill Plug (2 req.)
24	76362	Pressure Relief Ball (1 req.)	50	72657	1/4" NPT Pipe Plug (1 req.)
25	78692	M5-0.8 x 8mm Screw (1 req.)	51	83153	Outer Gerotor — 6/5 (1 req.)
26	78606	M6-1.0 x 12mm Screw (4 req.)	52	86254	O-ring — 17.8 I.d. x 2.4mm (1 req.)
27	76361	Thrust Washer (1 req.)	53	84186	Valve Spring Washer (2 req.)
28	89230	Flanged Hex Capscrew (6 req.)	54	88156	Valve Stem Seal (1 req.)
			57	82773J	Decal — Serial No. [70mm] (1 req.)



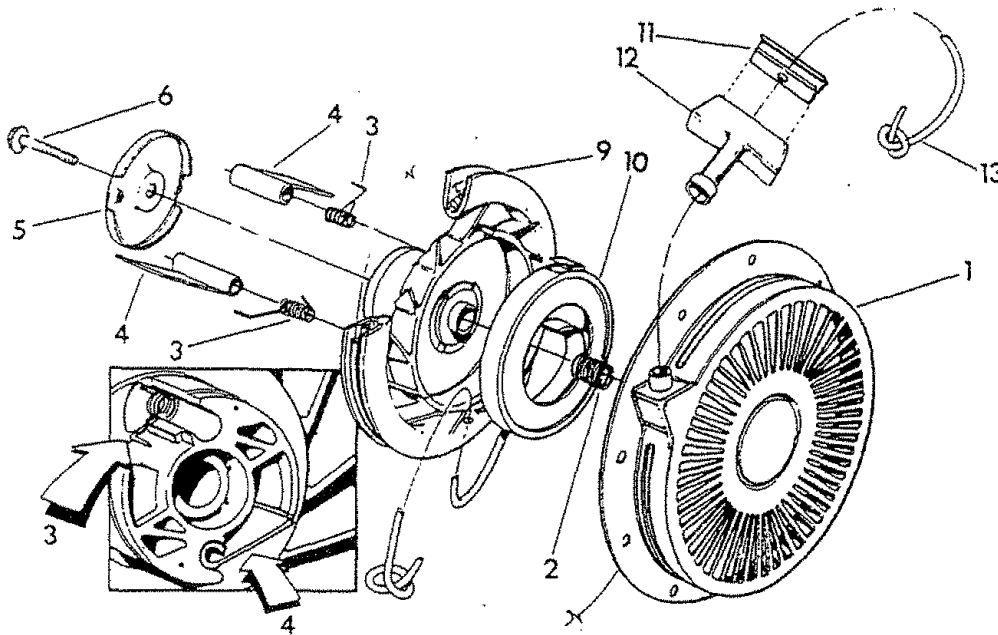

ITEM	PART NO.	DESCRIPTION
1	100-81671	REWIND STARTER HOUSING(1 REQ.)
2	105-81671	BRAKE SPRING(1 REQ.)
3	103-81671	DOG SPRING(2 REQ.)
4	104-81671	STARTER DOG(2 REQ.)
5	109-81671	RETAINER PAWL(1REQ.)
6	106-81671	RETAINER PAWL SCREW(1REQ.)
9	102-81671	PULLEY(1REQ.)
10	101-81671	SPRING AND KEEPER(1 REQ.)
11	108-81671	HANDLE INSERT(1 REQ.)
12	107-81671	STARTER ROPE WITH HANDLE(1REQ.)
13		ROPE (INCLUDED WITH ITEM 12)(1 REQ.)

Drawing No. 97020

FULL ONE YEAR WARRANTY ON CRAFTSMAN HIGH PRESSURE WASHER

For one year from the date of purchase, when this Craftsman High Pressure Washer is maintained and operated according to the instructions in the owner's manual, Sears will repair, free of charge, any defect in material and workmanship.

If this washer is used for commercial purposes, this warranty applies for only 90 days from the date of purchase.

If this high pressure washer is used for rental purposes, this warranty applies for only 30 days after date of purchase.

FULL TWO YEAR WARRANTY ON CRAFTSMAN ENGINE

For two years from the date of purchase, when this Craftsman engine is maintained and operated according to the instructions in the owner's manual, Sears will repair, free of charge, any defect in material and workmanship.

If the Craftsman Engine is used for commercial or rental purposes, this warranty applies for only one year from the date of purchase.

This warranty does not cover:

- Expendable items such as spark plugs and air filters, which become worn during normal use.
- Repairs necessary because of operator abuse or negligence, including damage resulting from no water being supplied to pump or failure to maintain the equipment according to the instructions contained in the owner's manual.

WARRANTY SERVICE IS AVAILABLE BY RETURNING THE HIGH PRESSURE WASHER TO THE NEAREST SEARS SERVICE CENTER/DEPARTMENT THROUGHOUT THE UNITED STATES.

This warranty gives you specific legal rights and you may also have other rights, which vary from state to state.

SEARS, ROEBUCK AND CO., D/817 WA, Hoffman Estates, IL 60179

SEARS

OWNER'S MANUAL

MODEL NO.

580.751651

IF YOU NEED REPAIR SERVICE OR PARTS

FOR REPAIR SERVICE CALL
THIS TOLL FREE NUMBER
1-800-4-REPAIR

(1-800-473-7247)

FOR REPLACEMENT PARTS
INFORMATION AND ORDERING,
CALL THIS TOLL FREE NUMBER:
1-800-FON-PART

(1-800-366-7278)

CRAFTSMAN®

6.5 HORSEPOWER

2200 PSI 3 GPM

HIGH PRESSURE WASHER

Each High Pressure Washer has its own model number. Each engine has its own part number. Each engine has its own model number.

The model number for your pressure washer will be found on a decal attached to the unit.

The part number for your engine will be found in the parts list.

All parts listed herein may be ordered through Sears, Roebuck and Co. Service Centers and most Retail Stores.

WHEN ORDERING REPAIR PARTS, ALWAYS GIVE THE FOLLOWING INFORMATION:

- **PRODUCT — HIGH PRESSURE WASHER**
- **MODEL NUMBER — 580.751651**
- **PART NUMBER**
- **PART DESCRIPTION**

Your Sears merchandise has added value when you consider that Sears has service units nationwide staffed with Sears trained technicians....professional technicians specifically trained on Sears products, having the parts, tools and the equipment to ensure that we meet our pledge to you, we service what we sell.

SEARS, ROEBUCK and CO., Hoffman Estates, IL 60179 U.S.A.