

# GoWISEUSA®

## Instruction Manual

ELECTRIC AIRWISE FRYER WITH ACCESSORIES

GWAC981, GWAC982, GWAC983



[www.gowiseusa.com](http://www.gowiseusa.com)

For indoor household use only

# Table of Contents

Product Introduction . . . . .	3
Important Safeguards. . . . .	4
Features . . . . .	7
Before First Use . . . . .	8
Display Controls . . . . .	9
How To Use Your Air Fryer . . . . .	11
Cooking Guide . . . . .	13
Cleaning Your Air Fryer . . . . .	15
Troubleshooting . . . . .	16
Warranty . . . . .	17
Authorized Retailers. . . . .	19



# Product Introduction

GoWISE USA would like to introduce the GWAC981 (Black), GWAC982 (Red), GWAC983 (Mint) Airwise Fryers with Rapid Air Technology. Rapid Air Technology is a new technique for preparing food that traditionally needs to be fried in oil. Rapid Air Technology works by quickly circulating hot air around the Air Fryer pan. The best part – it heats food in all directions, and most dishes cook with little to no oil.

This 5.3-quart Airwise Fryer features 8 built-in pre-sets including Fries, Pork, Chicken, Shrimp, Steak, Cake, Vegetables, and Fish. It offers a wide temperature range from 170°F - 400°F and a timer up to 60 minutes.

Take your air frying to the next level with the included accessory kit! Enjoy 7 perfectly-sized accessories to expand your air fryer's capabilities. Bake a cake or mini cupcakes with the baking accessories, roast kebabs using the hanging rack, even make a personal pan pizza in the 8-inch pizza/pie pan. Explore these possibilities and more with our air fryer accessories.

# Important Safeguards

1. READ THE ENTIRE MANUAL BEFORE ATTEMPTING TO OPERATE.
2. Keep the box and packing material for storage.
3. Do not immerse the cord, plug, or any part of the appliance in water or any other liquids to avoid electric shock.
4. Do not over fill the Fry Basket - avoid any ingredients from coming in contact with the heating element.
5. Do not cover the air intake or hot air exhaust when the appliance is on.
6. Do not fill the pan with oil. Filling the pan with oil may cause a fire hazard.
7. Do not touch the inside of the appliance while it is hot.
8. Do not use the appliance if there is any damage to the plug, main cord, or other parts.
9. Do not go to any unauthorized person to replace or fix the appliance.
10. Keep the cord away from hot surfaces.
11. Do not plug in or use the appliance with wet hands.
12. Make sure that the appliance is plugged into the wall socket properly.
13. Make sure that the appliance is out of reach of children, especially when the fryer is operating.
14. Do not connect the appliance to an external timer switch.
15. Do not place the appliance on or near combustible materials, such as a tablecloth or curtain.
16. Do not place the appliance against a wall or any other appliances. Leave at least 5 inches of free space around and above the appliance.
17. Do not place anything on top of the appliance.

# Important Safeguards

18. Do not use the appliance for any other purposes other than described in this manual.
19. Do not leave the appliance while it is operating.
20. During hot air frying, hot steam is released through the hot air exhaust openings. Keep your hands and face at a safe distance from the steam and exhaust openings. Be careful of hot steam and air when you remove the pan from the appliance. Any accessible surface may become hot during use.
21. Immediately unplug the appliance if you see dark smoke coming from either the vents or fry basket. Wait for the smoke emission to stop before you remove the pan from the appliance.
22. Ensure that the appliance is placed on a horizontal, even, and stable surface.
23. This appliance is designed for household use only. It is not safe to use in the environment such as staff kitchens, farms, motels, and other non-residential environments.
24. The warranty is void if the appliance is used for professional or semi-professional purposes, or it is not used according to instructions.
25. Always wait 30 minutes for the appliance to cool down before handling or cleaning it.
26. The Air Fryer base vents heat during the cooking process. Artificial stone countertops are not heat resistant - use a silicone pad or spare, non-artificial tile to protect your counters from heat damage.

# Important Safeguards

## Polarized Plug

This appliance has a polarized plug (one blade is wider than the other). As a safety feature to reduce the risk of electrical shock, this plug is intended to fit in a polarized outlet only one way. If the plug does not fit fully in the outlet, reverse the plug. If it still does not fit, contact a qualified electrician. Do not attempt to modify the plug in any way. If the plug fits loosely in the AC outlet or if the AC outlet feels warm do not use that outlet.

## Electromagnetic Fields

This GoWISE USA Air Fryer complies with all standards regarding Electromagnetic fields. Under proper handling, there is no harm done to the human body based on available scientific evidence.

If you have any questions regarding your Air Fryer, please contact Customer Service at 855-233-9199 or [support@gowiseusa.com](mailto:support@gowiseusa.com).

## Product Specification

Voltage: 120V~60Hz

Wattage: 1700 Watts

Capacity of basket: 5.3 Quart

Adjustable temperature: 170°F - 400°F

Timer: 0-60 min

# Features

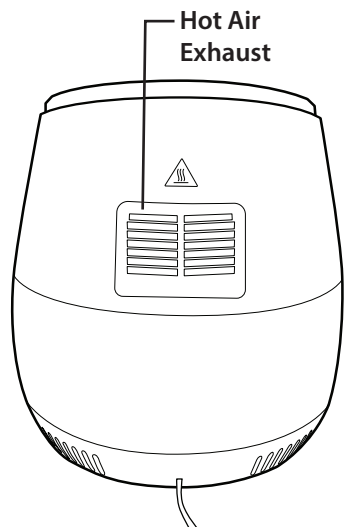
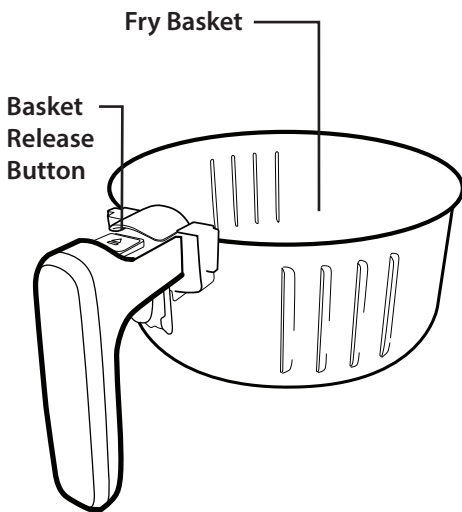
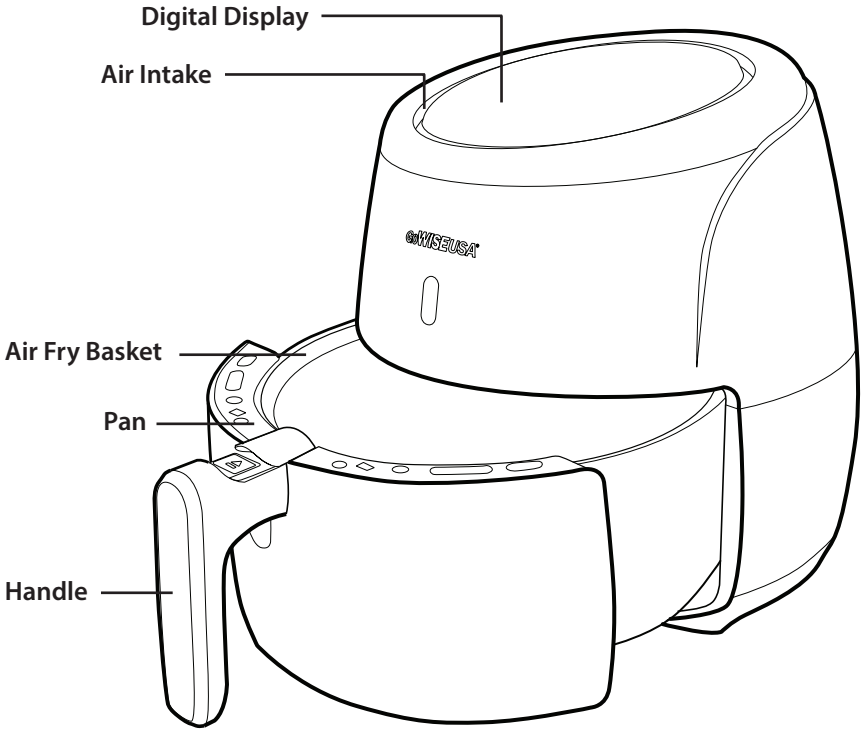

# Before First Use

1. Remove all packaging materials, stickers, and labels.
2. Clean the basket and pan with hot water, soap, and a non-abrasive sponge.
3. Wipe the inside and outside of the appliance with a clean cloth

Note: DO NOT fill the pan with oil or lard. The appliance uses rapid air circulation to fry.

# Display Controls

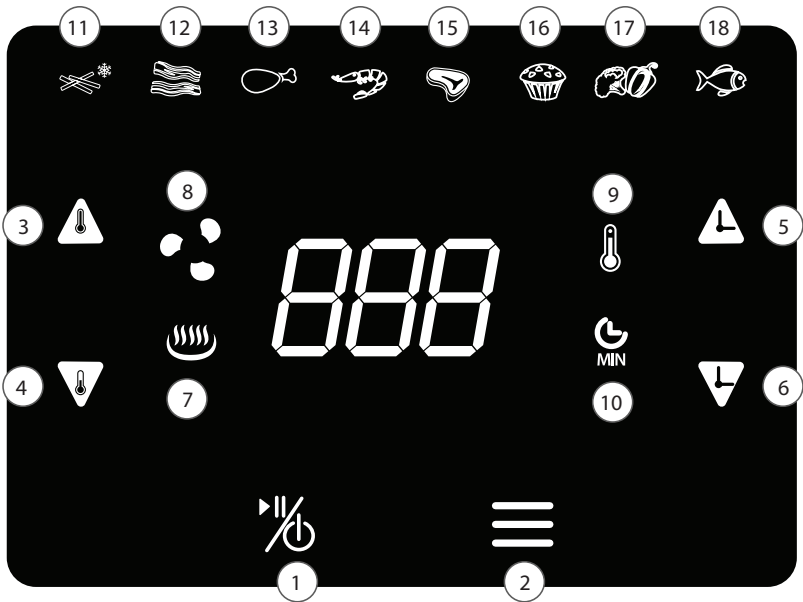

## Controls

### 1. Power Button: (Power, Pause, Resume)

Powers on Air Fryer; once on, select a cooking preset or adjust to desired Time and Temperature – press the Power Button again to start the cooking process.

To Pause the cooking process (useful when flipping or shaking food), press the Power Button while cooking. Press the Power Button once more to resume cooking.

To power off the air fryer, press and hold the Power Button for three seconds.

### 2. Preset Menu Button:

Toggles through the Cooking Preset menu. Press until the desired preset is flashing. Press the Power Button to start the cooking preset.

# Display Controls

## **3+4.** Temperature Control Buttons:

Use the Up and Down arrows to adjust the cooking temperature in increments of 10°F. Holding either arrow adjusts Temp rapidly.

## **5+6.** Timer Control Buttons:

Add or decrease cooking time using the Timer Up and Down arrows. Press and hold the arrows to adjust time rapidly.

## **7.** Heating Indicator

## **8.** Fan Indicator

## **9.** Temperature Indicator

## **10.** Time Indicator

## **11-18** Cooking Presets

# How to use your Air Fryer

1. Place the air fryer on a flat and even surface. DO NOT PLACE THE FRYER ON A SURFACE THAT IS NOT HEAT RESISTANT.
2. Secure the pan and basket into the fryer. DO NOT FILL THE PAN WITH OIL OR ANY OTHER LIQUID.
3. Use the time control arrows located on the right side of the display to adjust the Timer to three minutes. Preheating your air fryer will ensure foods cook faster and more evenly. After the three minutes are up, remove basket from the fryer.

CAUTION: Be careful when handling the basket when hot. Do not press the Fry Basket Release button on the handle when removing it – this will detach the basket from the pan. The Fryer will automatically shut down when the pan is pulled out.

4. Place the ingredients in the basket and then put the basket and pan back into the appliance.
5. To set cooking time, adjust the timer using the up and down arrow icons on the right side of the display. To set cooking temperature, use the up and down arrows located on the left side of the display until the desired temperature has been inputted.
6. Once you have set your cooking time and temperature, the air fryer will automatically start.

# How to use your Air Fryer

## Detaching the Basket

1. Push the button guard back.
2. Press the air fryer basket release button while pulling up on the handle to free the basket from the pot.

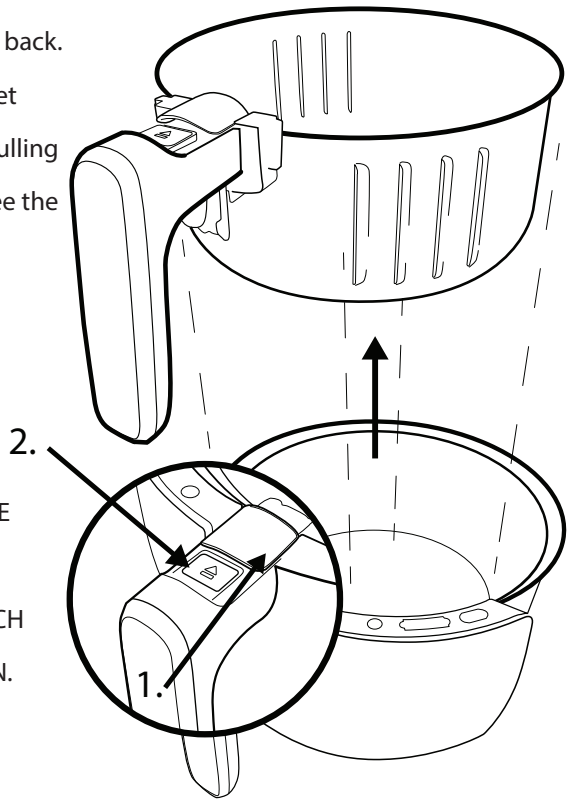

CAUTION: NEVER PRESS THE RELEASE BUTTON DURING SHAKING; THIS WILL DETACH THE BASKET FROM THE PAN.

To order replacement parts, please contact GoWISE USA Customer Service at 855-233-9199 or [support@gowiseusa.com](mailto:support@gowiseusa.com)

# Cooking Guide

Refer to this Time and Temperature Chart for any questions regarding the settings necessary for preparing specific foods and ingredients.

NOTE: Please keep in mind that because ingredients differ in size, shape, brand, and origin, we cannot guarantee that this is the best setting for the ingredients you have.

Rapid Air Technology reheats the air inside the fryer instantly; therefore, removing the pan from the air fryer for a brief period will not interrupt the cooking process.

## TIPS:

- Small ingredients usually require shorter cooking time than larger ingredients.
- Shaking smaller ingredients midway through the cooking process will ensure the ingredients cook more evenly and give a better result.
- Adding a very little amount of oil to fresh potatoes before frying will give them a crispier texture.
- Do not prepare extremely greasy ingredients in the air fryer.
- Snacks that can be prepared in the oven can also be prepared in the air fryer.
- The recommended quantity of french fries to Air Fry at a time is 17.5 oz.
- Pre-made dough requires shorter cooking time than home-made dough.
- When making a cake, quiche or ingredients with filling, use a baking tin or oven dish in the fryer basket.
- You can also use the air fryer to heat ingredients. Set the temperature to 170°F for up to 10 minutes.

# Cooking Guide

Food	Time (minutes)	Temperature (°F)	Shake/ Flip	Tips
<b>Potatoes &amp; Fries</b>				
Thin Frozen Fries	9-16	400°F	Shake	Add 1/2 Tbsp of Oil
Thick Frozen Fries	11-20	400°F	Shake	
Homemade Fries	16-20	400°F	Shake	
Homemade Potato Wedges	18-22	360°F	Shake	
Homemade Potato Cubes	12-18	360°F	Shake	
Falafel	15	360°F	Shake	
<b>15-18 Meat &amp; Poultry</b>				
Steak	8-12	360°F	Flip	Line with tin foil
Pork Chops	10-14	360°F	Flip	
Hamburger	7-14	360°F	Flip	
Bratwurst, Sausage	13-15	400°F	Flip	
Drumsticks	18-22	360°F	Flip	
Chicken Breast	10-15	360°F	Flip	
<b>Snacks</b>				
Spring Rolls	8-10	400°F	Shake	
Frozen Chicken Nuggets	6-10	400°F	Shake	
Frozen Fish Sticks	6-10	400°F	Shake	
Frozen Mozzarella Sticks	8-10	360°F	Shake	
Stuffed Vegetables	10	320°F		
<b>Baking</b>				
Cake	20-25	320°F		Use baking tin
Quiche	20-22	360°F		
Muffins	15-18	400°F		
Sweet Snacks	20	320°F		

If you have any questions regarding your air fryer, please contact Customer Service at 855-233-9199 or [support@gowiseusa.com](mailto:support@gowiseusa.com).

# Cleaning your Air Fryer

1. Clean the fryer after every use. Unplug the fryer. ALWAYS WAIT UNTIL THE FRYER HAS COOLED TO A SAFE TEMPERATURE BEFORE HANDLING.
2. Wipe the outside of the fryer with a moist cloth.
3. Clean the pan and basket with hot water, soap, and a non-abrasive sponge. You can remove any remaining food debris by using grease-cutting liquid soap. For any stuck on grease or food, soak the pan in hot water.
4. Clean the inside of the appliance with a lightly moistened non-abrasive sponge or cloth. Be careful not to get the inside of the appliance too wet. Clean the heating element with a cleaning brush to remove any food debris.

# Troubleshooting

<b>Problem</b>	<b>Possible Cause</b>	<b>Solution</b>
The Fryer is not turning on	The appliance is not plugged in	Plug the appliance into a grounded wall socket
	You have not set the timer	Set the timer using the knob for the correct time on the appliance
Ingredients undercooked	The basket has been overfilled	Place smaller batches of ingredients in the basket
	The set temperature is too low	Increase the temperature
The Ingredients are cooking unevenly	The basket maybe overfilled	Remove some of the contents or try shaking the basket midway through the cooking process
Food not crispy	Some foods are crispy when traditionally fried	Prepare traditional oven snacks or try lightly brushing oil on foods before air frying
Pan not sliding into the fryer	Overfilled basket	Do not fill the basket beyond the MAX fill indicator
White smoke emitting from the fryer	White smoke is normal when cooking frozen or greasy foods	It is common while air frying greasy ingredients for a small/ large amount of oil to leak into the pan. Heating oil will produce white smoke, and the pan may heat up faster than usual. This does not affect the appliance or the food's result
	The pan is still greasy	Clean pan properly after each use
Fresh fries cook unevenly	Potatoes are not fresh	Use fresh potatoes and make sure that they stay firm during frying
	Potato have not been rinsed thoroughly before cooking	Make sure to rinse the potato to remove the starch before frying
Fries are not crispy	Raw potato have not dried before cooking	Potato should be dry before adding oil
		Add more oil for a crispier result

# Warranty

General Warranty excludes refurbished / auction items.

GoWISE USA has a 1-year limited warranty for all products. Products are warrantied against defects in materials and workmanship for 1 year from the date of purchase, when used in accordance with the instructions provided. This warranty does not cover damages or wear resulting from accident, misuse, abuse, commercial use, or unauthorized adjustment and/or repair.

GoWISE USA shall not be liable for loss of use or any other incidental, consequential or indirect costs, expenses or damages. There are no express warranties except as listed above. This warranty gives you specific legal rights and you may have other rights which vary from state to state.

CALL 855-233-9199 for RETURN INSTRUCTIONS

WE DO NOT SERVICE PRODUCTS OUTSIDE THE 48 CONTINENTAL UNITED STATES. WE WILL SHIP TO A FREIGHT FORWARDER FOR CUSTOMERS.

NOTE: Customers are responsible for all return shipping costs. When item(s) are returned under warranty as being defective, they are thoroughly tested to verify manufacturer defect. If any item(s) are determined to be in proper working order after testing, all shipping cost to have the product returned to the customer will be the responsibility of the customer.

## Return Period: 30 Days

All return requests must be made within 30 days from the date our customers purchase their product(s). Refunds are only applicable during the 30-day return period and may be subject to restocking fees up to 15% of the original purchase amount. If the product is defective within 30 days, GoWISE USA will cover the cost of return shipping. However, a photo and/or video from the customer is required to receive a pre-paid shipping label. If the product is missing any accessories that were included in the original packaging/shipment, or the product is damaged, altered or used, the item may no longer be eligible for a refund or replacement. Any decision of refund and/or replacement will be decided at the discretion of GoWISE USA.

NOTE: Customers are responsible for all return shipping costs after 30 days.

# Warranty

## Defective/Freight Damaged:

Products that are within the 30-day return period and have been determined by customer service to be defective are qualified for a return label for the product to be returned to GoWISE USA for inspection and testing. GoWISE USA will provide a return shipping label for defective product(s) only. Customers must contact the carrier (shipping company) for products that have arrived damaged after initial transit. Clear photographic and video proof of damage and/or defective product(s) is REQUIRED prior to GoWISE USA authorizing the return of any product.

## Purchase from 3rd Parties:

In order for the GoWISE USA customer service team to lookup the warranty information regarding the product(s), the original order information and/or proof of purchase is required. Without this information, GoWISE USA will be unable to move forward with providing a replacement under warranty, as we do not know the date or origin of the purchase. GoWISE USA does not have a working business relationship with 3rd party selling sites or services or individuals which are not listed below as one of our authorized retailers. GoWISE USA is not responsible for making inquiries to such 3rd parties for the purpose of obtaining documentation. It is the responsibility of the person(s) making the warranty claim to provide original documentation such as order information and/or a receipt so that customer service can process the request. Any claim made under GoWISE USA warranty guidelines must be made by original purchaser of the product(s). Any defective product(s) will be replaced as long as the issues with the device fall within warranty guidelines.

# Authorized Retailers

Amazon

GoWISE USA

WayFair

Houzz

Home Depot

etailz

MorningSave.com

Bed Bath & Beyond

Jet.com

Walmart.com

**GoWISEUSA®**

[www.gowiseusa.com](http://www.gowiseusa.com)

[support@gowiseusa.com](mailto:support@gowiseusa.com)

855-233-9199

- To ensure the correct use of this appliance, read these instructions carefully and thoroughly.
- Please keep this manual for future reference.
- Thank you for purchasing this GoWISE USA electric Airwise Fryer.

USE PROMO CODE: **LIVewiseraF**

**10%  
OFF**

YOUR NEXT **GoWISEUSA®** PURCHASE

