



BUILT-IN COOKING APPLIANCES

User Manual



CONGRATULATIONS

Congratulations and thank you for choosing our Built-in Cooking Appliance. We are sure you will find your new appliance a pleasure to use and a great asset to your cooking. Before you use the appliance, we recommend that you read through the whole user manual which provides a description of the product and its functions.

To avoid the risks that are always present when you use a cooking appliance, it is important that the appliance is installed correctly and that you read the safety instructions carefully to avoid misuse and hazards. For future reference, please store this booklet in a safe place. This appliance complies to the requirements of Australian Standard AS/NZ 60335.2.6

Record model and serial number here:

Model:

Serial number:

The symbols you will see in this booklet have these meanings:



warning

Indicates information concerning your personal safety



caution

Indicates information on how to avoid damaging the appliance



tips & information

Indicates tips and information about use of the appliance



environmental tips

Indicates tips and information about economical and ecological use of the appliance



tips & information

Important – check for any damage or marks

If you find the appliance is damaged or marked, you must report it within 7 days if you wish to claim for damage/marks under the manufacturer's warranty. This does not affect your statutory rights.



environmental tips

Information on disposal for users

- Most of the packing materials are recyclable. Please dispose of those materials by contacting your local authorities and ask for the correct method of disposal.

Contents

Description of your appliance	4
EOC617	4
EOC627	4
EOC647	4
EGC627	4
EXC617	4
EXC627	5
63K906	4
63K914	4
Before operating your appliance for the first time ..	5
Setting the time	5
Preparing your appliance for the first time	5
Installing your oven accessories	6
Using your oven	7
Understanding your oven functions	7
Cooling/venting fan	8
Condensation	8
Operating your oven temperature selector	8
Pre-heating your appliance	8
Operating the programmable clock	9
3 button programmable clock	9
Cooking guide	10
Oven shelf location	10
Choosing the best oven settings	11
Roasting meat	12
Roasting poultry and fish	12
Grilling guide	13
Grilling hints	13
Guide to better grilling	13
Turbo Grill (Multi-function models only)	13
Dealing with cooking problems	14
Cleaning your appliance	15
Enamel	15
Stainless Steel	15
Glass	15
Painted Control Panel	15
Oven	15
Grill	15
Cleaning your oven accessories	15
Cleaning your oven door	17
Solving problems	18
Installation	19
Cabinet construction for your appliance	20
Oven Dimensions	20
Underbench Ovens	20
Separate Grill Underbench Ovens	21
Separate Grill Wall Ovens	22
Hard wiring detail	22
Warranty	23

general safety

An important read to avoid an electric shock or fire

Meanings of symbols used in this manual are shown below:



This symbol indicates never to do this



This symbol indicates always do this

- ⊘ The appliance is NOT suitable for use by children, without supervision.
- ✔ Young children should be supervised to ensure they do not play with this appliance.
- ⊘ This appliance is not intended for use by persons (including children) with reduced physical, sensory or mental capabilities, or lack of experience and knowledge, unless they have been given supervision or instruction concerning use of the appliance by a person responsible for their safety.
- ✔ During use this appliance becomes hot. Care should be taken to avoid touching hot external and internal surfaces when in use. Use oven gloves. Children should be kept away to avoid burns and scalds.
- ⊘ This appliance must NOT be used as a space heater.
- ⊘ DO NOT spray aerosols in the vicinity of this appliance while it is in operation.
- ⊘ DO NOT store flammable materials in the appliance storage drawer or near this appliance e.g. Aerosols.
- ✔ Ensure all specified vents, openings and airspaces are not blocked in order to avoid a fire.
- ⊘ DO NOT line the bottom of the oven or grill with foil or cookware.
- ⊘ DO NOT MODIFY THIS APPLIANCE.

Oven warnings

- ✔ During use the appliance becomes hot. Care should be taken to avoid touching hot surfaces inside the oven.
- ✔ Switch the appliance off before removing the oven light glass for globe replacement.
- ✔ To avoid an accident, ensure that oven shelves and fittings are always inserted into the appliance in accordance with the instructions.
- ⊘ Do not use the door as a shelf.
- ⊘ Do not push down on the open oven door.

Grill warnings

- ⊘ DO NOT leave grill on unattended.
- ✔ The grill door must be left fully open whilst grilling in a separate grill wall oven.
- ✔ The grill drawer must be left approx. two finger widths ajar whilst grilling in a separate grill underbench oven.
- ✔ Always turn the grill off immediately after use as fat left there may catch fire.
- ⊘ Do not cover the insert with foil, as fat left there may catch fire.
- ✔ Always keep the grill dish clean as any fat left may catch fire.
- ✔ To avoid a fire, ensure that grill trays and fittings are always inserted into the appliance in accordance with the instructions.
- ⊘ Do not place thick portions of food under the grill. Foods may curl, catch and ignite.
- ✔ Accessible parts may become hot when grill is in use. Children should be kept away.

Installation, cleaning and servicing

- ✔ Only authorised personnel must install and carry out servicing this appliance. (Certificate of Compliance to be retained)
- ✔ Before using the appliance, ensure that all packing materials are removed from the appliance.
- ✔ In order to avoid any potential hazard, the enclosed installation instructions must be followed.
- ✔ Ensure that all specified vents, openings and airspaces are not blocked.
- ✔ Where the appliance is built into a cabinet, the cabinet material must be capable of withstanding 70°C.
- ✔ Always ensure the appliance is switched off before cleaning or replacing parts.
- ⊘ Do not use steam cleaners, as this may cause moisture build up.
- ✔ Always clean the appliance immediately after any food spillage.
- ✔ To maintain safe operation, it is recommended that the product be inspected every five years by an authorised serviceperson.

This appliance must be earthed.

description of your appliance

Model: EOC617 Underbench Oven Conventional



Model: EOC627/63K906 Underbench Oven Fan Forced



Model: EXC617 Separate Grill Wall Oven Conventional

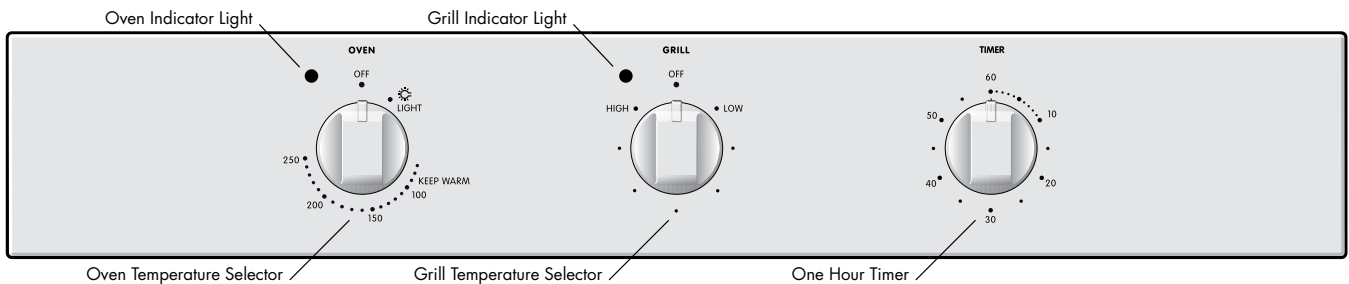

Model: EGC627/EXC627 Separate Grill Underbench Fan Forced/Separate Grill Wall Oven Fan Forced

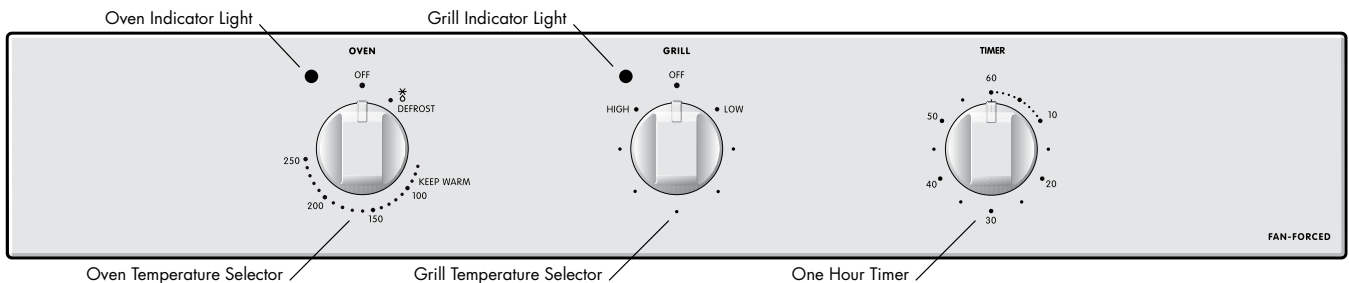

Model: EOC647/63K914 Underbench Oven Multifunction 5

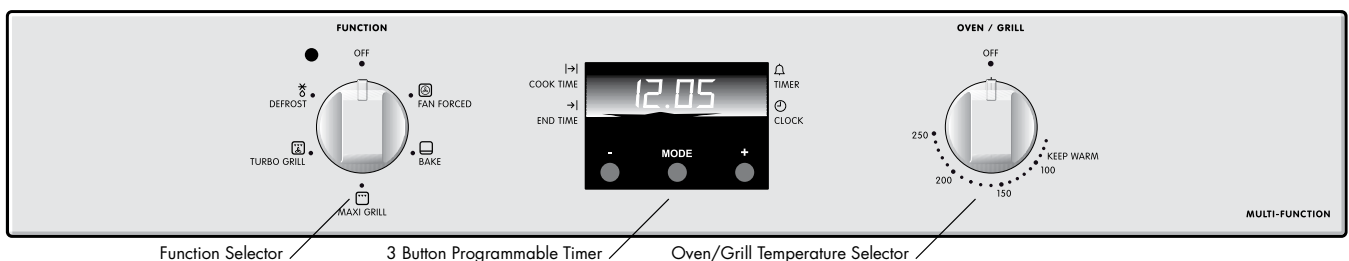

before operating your appliance for the first time

tips & information

Setting the time

If you have purchased a model fitted with an electronic or programmable timer, you **MUST** set the time of day before you can operate your appliance.



3 Button Electronic Clock

- After the appliance has been electrically connected '12.00' will be displayed and the 'clock indicator' will flash.
- To set the time of day, press the - or + buttons. 5 seconds after the last change, the "clock indicator" will disappear, confirming the time has been set.

NOTE: The clock has a 24-hour display.

Preparing your appliance for the first time

- Please remove all internal boxes and bags from the oven before operation.
- Please wipe out the oven interior prior to operation with warm soapy water and polish dry with a soft clean cloth. Do not close the oven door until the oven is completely dry.
- New appliances can have an odour during first operation. It is recommended to 'run in' your oven before you cook for the first time. Run the oven at 180°C for 2–4 hours and ensure that the room is well ventilated.

Installing your oven accessories

The type of oven furniture you receive is dependant on the model you have purchased.

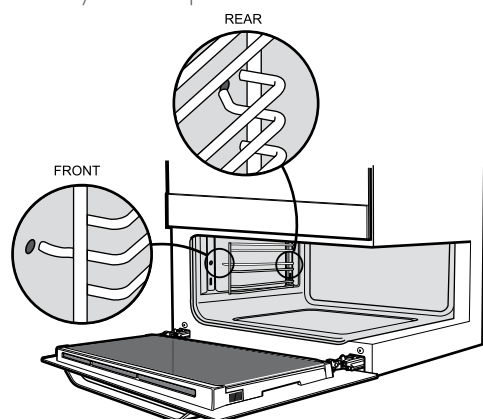

1. Side racks

Separate grill wall ovens come with side racks that are to be fitted to the smaller "grill cavity".

These can be attached to either side in the following manner.

- Insert the largest peg into rear access hole provided. See diagram above.
- Then locate the front peg into the front access hole and push in firmly.

2. Shelves and trays

Your oven comes with formed "easy clean" runners. The shelves are designed to travel freely on runners without being pulled out accidentally. Make sure you have the shelf in the correct orientation before you slide it in. Otherwise it could become jammed.

- Locate the rear edge of the shelf in the recess between 2 formed runner. See diagram below.

NOTE: The Top 'Ledge' is not a shelf position

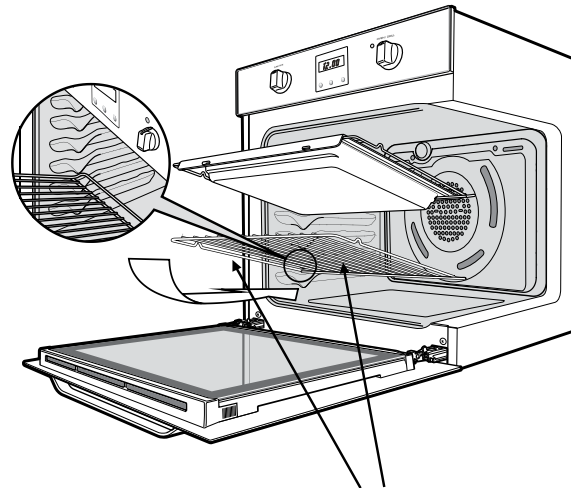

Note the orientation of the side and rear features

- With the front edge raised, begin to slide the shelf into the oven. Lower the front edge as you push the shelf completely in.
- The grill/baking tray for underbench oven models sits into a wire carrier that fits into the oven exactly like the shelves.
- The grill/baking tray for separate grill wall oven models slides into the wire runners in a similar manner.
- When fully inserted, the shelf/tray should not interfere with the closed oven door.

before operating your appliance for the first time

- To insert the grill tray in a separate grill underbench, fully open the grill drawer and position the tray so that the slots on the outer edges fit on the tabs on the slides.

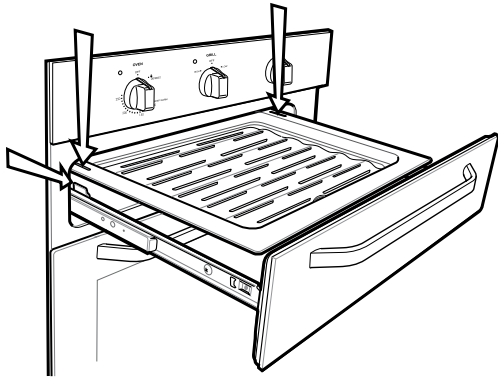

Separate grill underbench

- Always remove unnecessary trays and dishes from oven when roasting or baking.

using your oven

Understanding your oven functions

Your oven will have a selection of the following functions. Refer to "Description of your appliance" (page 4) to confirm what functions are available to you.

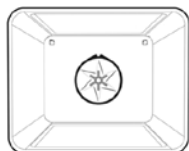

Fan Forced

Heat comes from the element surrounding the fan. This fan circulates the hot air around the oven cavity so that you can put your food in different places in the oven and still cook them at the same time.

You can use the "fan forced" function for multi-shelf cooking, reheating cooked foods, pastries and complete oven meals. It will cook at a lower temperature and be faster than baking. Please note that some variation in browning is normal.

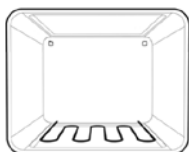

Bake

Heat comes from the element below the food. The element is controlled by the thermostat and will turn on and off to maintain the set temperature.

The "bake" function can be used to add extra browning to the bases of pizzas, pies and pastries. Cook in the lower half of the oven when you are using only one shelf.

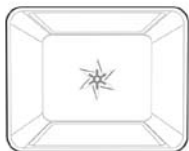

Defrost

The "defrost" function uses low temperature air that is circulated by the fan. You can defrost (thaw) your food before you cook it. You can also use "defrost" to raise your yeast dough and to dry fruit, vegetables and herbs.

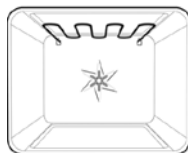

Turbo Grill

"Turbo grill" offers you the benefits of both "bake" and traditional "grill" functions. The grill element turns on and off to maintain the set temperature while the fan circulates the heated air. The oven door remains closed. You can use "Turbo grill" for large cuts of meat. This gives you a result that is similar to "roisserie" cooked meat. Put your food on a shelf in the second lowest shelf position. Put the grill dish on the lowest shelf position to catch any spills. When using "Turbo grill" it is not necessary to turn the food over during the cooking cycle. Set temperature to 180°C.

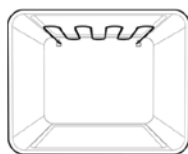

Grill

The "grill" directs radiant heat from the powerful upper element onto the food. You can use the "grill" function for tender cuts of meat, steak, chops, sausages, fish, cheese toasties and other quick cooking foods. Grill with the oven door closed. Preheat your grill for 3 minutes to get the best results. This will help seal in the natural juices of steak, chops etc. for a better flavour. You can slide your grill dish into either of the 2 spaces within the upper pairs of support rails.



Maxi Grill

"Maxi grill" directs radiant heat from 2 powerful upper elements onto the food. You can use the "maxi grill" function for tender cuts of meat, steak, chops, sausages, fish, cheese toasties and other quick cooking foods. Grill with the oven door closed.

"Maxi grill" allows you to take full advantage of the large grill dish area and will cook faster than normal "grill". For best results it is recommended to preheat your grill for 3 minutes. This will help seal in the natural juices of steak, chops etc. for a better flavour. You can slide your grill dish into either of the 2 spaces within the upper pairs of support rails.

using your oven

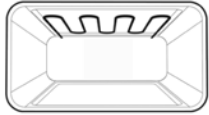

Separate Grill

The “grill” directs radiant heat from the powerful upper elements onto the food. You can use the “grill” function for tender cuts of meat, steak, chops, sausages, fish, cheese toasties and other quick cooking foods. Grill with the oven door open. Preheat your grill for 3 minutes to get the best results. This will help seal in the natural juices of steak, chops etc. for a better flavour. The grill dish is to be positioned between the upper pair of support rails.

Cooling/Venting fan

Your built-in appliance is fitted with a cooling fan. It will operate whenever you are using your oven or grill and will blow warm air across the top of the oven door. In some appliances the cooling fan may continue to operate after the appliance is turned off. This is to cool the product.

Condensation

Excess condensation may fog the oven door. This may happen when you are cooking large quantities of food from a cold start. You can minimize condensation by:

- Keeping the amount of water used whilst cooking to a minimum.
- Making sure that the oven door is firmly closed.
- Baking custard in a baking dish that is slightly smaller than the water container.
- Cooking casseroles with the lid on.

NOTE: If you are using water in cooking, this will turn to steam and may condense outside your appliance. This is not a problem or fault with your oven.

Operating your oven temperature selector

A thermostat controls the temperature in your appliance. The temperature can be selected within the specified range. To set the temperature, turn the temperature selector in a clockwise direction to the desired setting. An indicator light above the temperature selector will come on. When the temperature is reached, the heating source switches itself off and the indicator light goes out. When the oven temperature falls below the desired setting, the heating source switches on and the indicator light comes on again. Once the food is cooked, turn the temperature selector back in an anti-clockwise direction. Do not force it right round in a clockwise direction as this will result in damage to the thermostat.

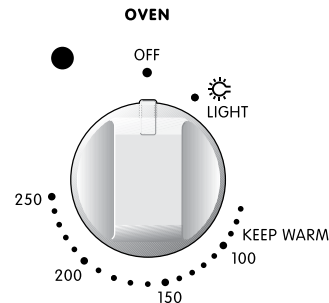

NOTE: For multifunction ovens the desired cooking function must be selected before the oven will operate. Once the desired function has been selected, use the temperature selector to set the required temperature.

Pre-heating your appliance

Pre-heating your oven is recommended in cooking and grilling functions. For best results when baking you must preheat your oven for 30 minutes.

With “Fan Forced”

1. It is recommended to preheat your appliance when cooking or baking.
2. Set the desired temperature, by rotating your oven temperature selector.

When the indicator light above the temperature selector goes out, the oven has reached the desired temperature, place your food into the oven, close the door and set the timer if you desire.

With “grill”

Preheat the grill for at least 3 minutes to obtain best results. This will help to seal the natural juices of steak, chops and other meats for a better flavour.

Setting temperatures

The following table displays the temperature settings for recipes which do not show actual temperatures.

	Oven	Temperature °C	Temperature °F
	Cool	80	175
Low Heat	Very slow	100 – 110	210 – 230
	Slow	130 – 140	265 – 285
Moderate Heat	Moderately slow	150 – 160	300 – 320
	Moderate	170 – 180	340 – 355
High Heat	Moderately hot	190 – 200	375 – 390
	Hot	200 – 210	390 – 410
	Very hot	220 – 230	430 – 450
	Extremely hot	240 – 250	465 – 480

operating the programmable clock

3 button programmable timer

General features

Your 3 button programmable timer has the following features:

- **Timer** – your 3 button programmable timer allows you to set a countdown time that will beep when the set time has elapsed.
- **Cooking duration** – You can set a cooking duration. A timer will count down the preset cooking time, beep when the time has elapsed and turn the oven off.
- **End cooking time** – you can set a cooking finish time. A timer will count down the preset cooking time, beep when the finish time has been reached and turn the oven off.
- **Delayed start cooking time** – You can combine the cooking time and stop cooking time to switch the oven on and off at a specific time during the day.

NOTE: Your 3 button programmable timer only operates with your main oven.

Setting the time of day

You must set the time of day before you can operate your appliance. When power is supplied to your oven "12.00" will be displayed and the "clock" indicator ■ will flash.

1. To set the time of day in hours and minutes, press the – or + buttons. 5 seconds after the last change, the "clock" indicator ■ will disappear, confirming the time has been set.

NOTE: The clock has a 24-hour display.

Setting the timer

1. Press the "mode" button until the "timer" indicator ■ begins flashing.
2. Set the countdown time you want by using the – and + buttons. 5 seconds after the last change the "timer" indicator ■ will stop flashing, confirming the timer has been set.
3. To stop the beeper, press any button.

Setting the cooking duration

1. Check the clock displays the correct time of day.
2. Select the desired oven function and temperature. The oven indicator light will glow and the heating source will come on.
3. Press the "mode" button until the "cook time" indicator ■ begins flashing.
4. Set the cooking duration you want by using the – or + buttons. 5 seconds after the last change, the "cook time" indicator ■ will stop flashing, and the time of day will be displayed.

NOTE: Do not forget to add preheating time if necessary.

Setting the cooking end time

1. Check the clock displays the correct time of day.
2. Select the desired oven function and temperature. The oven indicator light will glow and the heating source will come on.
3. Press the "mode" button until the "end time" indicator ■ begins flashing.
4. Enter the time of day you want to finish cooking by pressing the – or + buttons. 5 seconds after the last change, the "end time" indicator ■ will stop flashing and the current time of day will be displayed.

Setting the delayed start cooking time

1. Program the "cook time" and "end time" as described in the relevant sections. Once both the "cook time" and "end time" have been set, the "cook time" and "end time" indicators will stop flashing and the current time of day will be displayed.

To check or cancel settings

1. To check your settings, press the mode button until the setting you want is displayed. A red light will flash next to the mode (cook time, end time etc) that is currently on display.
2. To cancel "delayed start" press the mode button until a light flashes next to "end time". Press and hold the – button until the clock no longer reverses (you will hear a beep). If you have left the temperature and function knobs at a setting the oven will start once the "end time" light stops flashing.
3. To cancel "auto shut off" press the mode button until a light flashes next to "cook time". Press and hold the – button until the clock no longer reverses at ("0:00" and you will hear a beep). This automatically cancels "delayed start". If you have left the temperature and function knobs at a setting, the oven will start once the "cook time" light stops flashing. Because you have cancelled "auto off" the oven will continue to heat until you manually turn it off.

On completion of cooking

The oven will turn off, the timer will beep and the "end time" and/or "cook time" indicators will flash.

1. Turn the function and temperature controls to the off position.
2. Press any button to stop the timer from beeping.

cooking guide

- Select the correct shelf location for food being cooked.
- Make sure dishes will fit into the oven before you switch it on.
- Keep edges of baking dishes at least 40mm from the side of the oven. This allows free circulation of heat and ensures even cooking.
- Do not open the oven door more than necessary.
- Do not place foods with a lot of liquid into the oven with other foods. This will cause food to steam and not brown.
- After the oven is turned off it retains the heat for some time. Use this heat to finish custards or to dry bread.
- Do not use a lot of cooking oil when roasting. This will prevent splattering oil on the sides of the oven and the oven door. Polyunsaturated fats can leave varnish like residue which is very difficult to remove.
- When cooking things which require a high heat from below (e.g. tarts), place the cooking dish on a scone tray in the desired shelf position.
- For sponges and cakes use aluminium, bright finished or non-stick utensils.

Oven shelf location

Your oven comes with formed “easy clean” runners that allow five positions for shelves. These are numbered from 1 (the lowest shelf position) to 5 (the highest shelf position). See diagram.

In general:

- When cooking with 1 shelf, use position 3.
- When cooking with 2 shelves, use position 2 and 4.

For more specific suggestions refer to the table on the following page.

Use the oven efficiently, by cooking many trays of food at the same time. For example:

- Cook 2 trays of scones, small cakes or sausage rolls.
- Cook a roast dinner at the same time as you cook chips or vegetables.

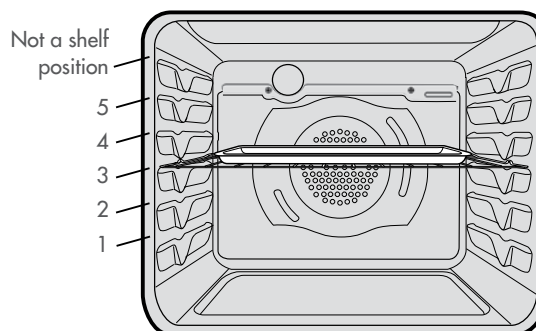

5 position rack

cooking guide

Choosing the best oven settings

The following table is intended as a guide and experience may show some variation in cooking times necessary to meet individual requirements. For best baking results preheat oven for 30 minutes.

Food	Non Fan Forced Mode		Fan forced oven		Time in minutes
	Temperature °C	Oven shelf position*	Temperature °C	Oven shelf position*	
Plain or fruit scones	220	2	210	Any	10 – 15
Rolled biscuits	170	2	150	Any	10 – 15
Spooned biscuits	190	2	180	Any	12 – 15
Shortbread biscuits	160	1 or 2	150	Any	30 – 35
Hard individual meringues	110	2	100	Any	90
Soft individual meringues	180	2	165	Any	15 – 20
Pavlova – 6 eggs	110	1	100	Any	75
Patty cakes	190	3	180	Any	15 – 20
Sponge – 4 eggs	180	2	170	Any	20 – 30
Shallow butter cake	180	2	170	Any	25 – 40
Rich fruit cake	140	2	130	Any	180
Shortcrust cornish pasty#	200	2	180	Any	40 – 45
Shortcrust custard tart	200/180	1	(180/160)		(10/35)
Cream puffs	210	2	200	Any	25 – 30
Yeast bread	210	1	200	Any	25 – 30

*Shelf position is counted from the bottom up. Bottom shelf is 1.

#Turn down temperatures and times shown.

cooking guide

Roasting Meat

1. Place the meat in the oven and set the temperature between 180°C and 200°C. (It is recommended to wrap your meats in an oven roasting bag or foil to prevent fats and oils from splattering, making it easier to clean your oven.)
2. Use the grill/oven dish and smokeless grill insert. Place the meat on the insert.
3. Do not pierce the meat, as this will allow juices to escape.
4. When the meat is cooked, take the roast out of the oven, wrap in aluminum foil and leave to stand for about 10 minutes. This will help retain the juices when the meat is carved. The table shows temperatures and cooking times for different kinds of meat. These may vary depending on the thickness or bone content of the meat.

Roasting poultry and fish

1. Place the poultry or fish in an oven set at a moderate temperature of 180°C.
2. Place a layer of foil over the fish for about three quarters of the cooking time.

The table shows temperatures and cooking times for different kinds of fish and poultry. These may vary depending on the thickness or bone content of the meat.

Meat/Poultry/Fish	Recommended temperature °C	Minutes per kilogram
Beef – Rare	200	35 – 40
– Medium	200	45 – 50
– Well done	200	55 – 60
Lamb – Medium	200	40
– Well done		60
Veal – Well done	180	60
Pork – Well done	200	60
Chicken	180	45 – 50
Duck	180 – 200	60 – 70
Turkey	180	40 – 45 (<10kg) 35 – 40 (>10kg)
Fish	180	20

grilling guide

Grilling hints



warning

NOTE: Always clean the grill/oven dish after every use. Excessive fat build up may cause a fire.

Depending on your model of appliance you will grill:

- With the door open, if you are grilling in the separate grill wall-oven compartment.
- With the drawer approximately two finger widths ajar, if you are grilling in the separate grill underbench compartment.
- With the door open or closed, if you are grilling in the oven compartment.

As a method of cooking, grilling can be used to:

- Enhance the flavours of vegetables, fish, poultry and meat.
- Seal the surface of the food and retain the natural juices.
- You can grill with the door open or closed.

This table shows how to grill different types of meat:

Beef	You can use tenderloin, rump, sirloin. Brush with oil or melted butter, especially if the meat is very lean.
Lamb	You can use loin chops, shortloin chops, chump chops, and forequarter chops. Remove skin or cut at intervals to stop curling. Brush with oil or melted butter.
Sausages	Prick sausages to stop skin from bursting.
Poultry	Divide into serving pieces. Brush with oil.
Fish	Brush with oil or melted butter and lemon juice.
Bacon	Remove rind. Grill flat and make into rolls.

Guide to better grilling

No definite times can be given for grilling because this depends on your own tastes and the size of the food. These times should only be used as a guide and remember to turn the food over half way through the cooking process.

Steak	15 – 20 minutes
Chops	20 – 30 minutes
Fish	8 – 10 minutes
Bacon	4 – 5 minutes

For better grilling results, follow these easy instructions:

1. Remove oven/grill dish and smokeless grill insert and preheat grill for about 5 minutes.
2. Choose only prime cuts of meat or fish. If the cut is less than 5mm thick it will dry out. If the cut is more than 40mm thick, the outside may burn whilst the inside remains raw.
3. Do not place aluminium foil under the food as this prevents fats and oils from draining away, which could result in a fire.
4. Baste the food during cooking with butter, olive oil or marinade. Grilled food is better if marinated before cooking.
5. Use tongs to turn food as a fork pierces the surface and will let juices escape.

Turbo Grill (Multifunction models only)

If your appliance has Turbo grill as a function, this will assist the grilling process by circulating the heat evenly around the food. The recommended temperature setting is 180°C for all fan grilling functions.

1. Use the smokeless grill insert and oven dish for all Turbo grilling.
2. Position the dish in the lower half of the oven, for best results.
3. Wipe off any oil or fat which spatters while the oven is still warm.

There is no need to turn the meat as both sides are cooked at the same time which means that the food is succulent.

dealing with cooking problems (see also page 18)

Problem	Causes	What to do
Uneven cooking	Incorrect shelf position	Select shelf that puts food in centre of oven
	Oven tray too large	Try other trays or dishes
	Trays not in centre	Put trays in centre
	Air flow in oven uneven	Rotate food during cooking
	Grill tray affecting thermostat	Remove grill tray from oven on bake modes
Baked products too brown on top	Oven not preheated	Preheat the oven
	Baking tins too large for recipe	Use correct size tins
	Baking tins not evenly spaced	Stagger baking tins at least 3cm between tins and the oven walls
	Products not evenly sized or spaced on trays	Make into same size and shape and spread evenly over trays
Baked products too brown on bottom	Baking tins too large	Use correct size tins
	Baking tins are dark metal or glass	Change to shiny, light tins or lower the temperature by 10°C
	Food too low in oven	Cook one shelf higher
	Oven door opened too frequently during baking	Don't open the oven door until at least half the cooking time has passed
	Baking temperature too high	Lower the temperature
	Grill tray affecting thermostat	Remove grill tray from oven on bake modes
Cakes have a cracked thick crust	Baking temperature too high	Lower the temperature
	Food too high in oven	Cook one shelf lower
	Cake batter over mixed	Mix just long enough to combine the ingredients
	Baking tin too deep	Check size of tin and use recommended size
	Baking tins dark	Change to shiny light tins
Baked products are pale, flat and undercooked	Baking temperature too low	Raise the temperature
	Food too low in oven	Cook one shelf higher
	Baking time too short	Increase cooking time
	Incorrect baking tin size	Use correct size tin
Cakes fallen in centre	Baking temperature too low	Raise the temperature
	Baking time too short	Increase cooking time
	Proportions of ingredients incorrect for recipe	Check recipe
	Opening door too early during baking	Do not open door until the last quarter of cooking time
Roast meat and potatoes not brown in fan oven	Poor hot air circulation	Elevate food onto a rack to allow air circulation
	Grill tray affecting thermostat	Remove grill tray from oven on bake modes
Juices running out of meat		Do not pierce meat with fork, turn with tongs
Grilled meats overcooked on outside & raw in the centre		Grill at lower insert position
Grilled chops & steaks curling		Cut into fat every 2cm (½")

get to know your oven

Get to know your new oven with this 'Simple Test Cake'

Although we strive for a perfect performing oven, it's possible that there will be some variation in colour when baking. Therefore, we suggest this simple, easy and delicious to make Simple Test Cake, it can help you understand your new oven. All ovens do sometimes have hot or cold spots, therefore it is important to judge with your eye as you may require to rotate during baking.

'Simple Test Cake'

125g butter, softened to room temperature

1 cup caster sugar

1 teaspoon pure vanilla essence

4 large eggs

2 cups self-raising flour

pinch of salt

4 tablespoons (80ml) full-cream milk

Method:

1. Butter base and sides of two, 20cm straight-sided round or square cake pans. Then line the base with grease proof or baking paper.
2. Preheat oven to moderate '180°C' (170°C fan forced) and ensure oven shelf is in the centre position of oven.
3. Cream softened butter and sugar until light in colour.
4. Add vanilla essence.
5. Then eggs one at a time, beating well after each addition.
6. Sift flour and salt into the mixture and beat until well combined.
7. Add milk and beat or stir to combine.
8. Spoon mixture equally between prepared cake pans.
9. Bake in preheated oven, middle shelf for about 25 to 35 minutes or until when tested with a fine cake skewer it comes out clean or the edges of the cakes have come away slightly from the sides of the cake pans.
10. Remove from oven to wire cake rack and rest for 5 minutes before removing from cake pans. Cool completely.

To Serve: sandwich together with your favourite jam or conserve, and dust top with pure icing sugar.

FOOT NOTE: if desired substitute butter for either margarine or olive oil spread.

Recipe is based on the Australian standard metric 250mL cup and 20mL tablespoon sets

cooking problems

tips & information

Important:

- Always make sure that the oven is electrically isolated before cleaning. This can be done via the functional switch located nearby. Do not use steam cleaners.
- Do not line the bottom of the oven or grill with foil or cookware as trapped heat will crack and craze the floor of the oven.

Enamel

- Rub persistent stains vigorously with a nylon scourer or creamed powder cleansers.

NOTE: You can also use household oven enamel cleaners – follow the manufacturer's instructions carefully.

- Do not use harsh abrasive cleaners, powder cleaners, steel wool or wax polishes.

Stainless steel

All grades of stainless steel can stain, discolour or become greasy. You must clean these areas regularly by following the procedures below, if you want your appliance to look its best, perform well and have a long life.

Care must be taken when wiping exposed stainless steel edges...they can be sharp!

- Wash with warm soapy water and rinse with clean water.
- If you want a better look, wipe your appliance with a suitable stainless steel cleaner then wipe with a soft lint free cloth.
- Use a stainless steel cleaner only where the stainless steel is extremely dirty and / or discoloured. A suitable cleaner can be purchased from Electrolux Service or Spares. See back cover.

NOTE: Make sure you follow the polish or brushing lines in the steel.

Glass

- Glass surfaces on doors are best cleaned immediately after soiling.
- A damp cloth may help remove baked on food deposits.
- Oven cleaners can be used to remove stubborn marks and stains.

Painted Control Panel & Door Trim

- Wash with soapy water and rinse with clean water. Wipe dry with a soft, lint free cloth.
- Do not use harsh abrasive cleaner, powder cleaners, steel wool or wax polishes.

Oven

- Always keep your appliance clean. Ensure that fats and oils do not accumulate around elements, burners or fans.
- Always keep the oven dish, bake trays and smokeless grill insert clean, as any fat deposits may catch fire.
- Always wrap your meats in foil or an oven roasting bag to minimise cleaning. Any polyunsaturated fats can leave a varnish-like residue which is very difficult to remove.

Grill

- Always keep the grill dish and smokeless grill insert clean, as any fat deposits may catch fire.

Cleaning your oven accessories

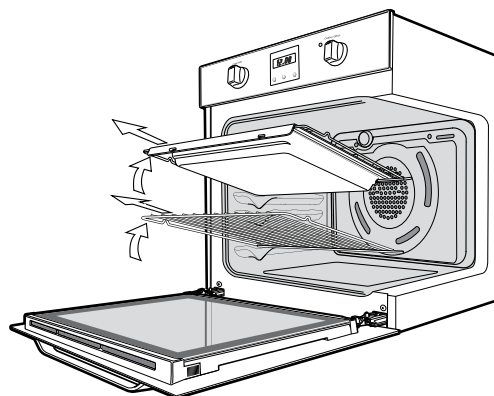

Removing the shelves from your appliance

- Slide the shelves towards you until they reach the front stop.
- Tilt them up at the front, taking care not to spill any contents.
- Lift them clear.
- Wash the dish and insert the shelves in hot soapy water.
- Reverse the above steps to put the grill dish and shelves back again.
- See page 5 for more details.

Removing the side racks (in separate grill wall ovens)

- Grasp the shelf supports at the front.
- Pull them firmly inwards.
- To install the side racks, see page 5.

cleaning your appliance

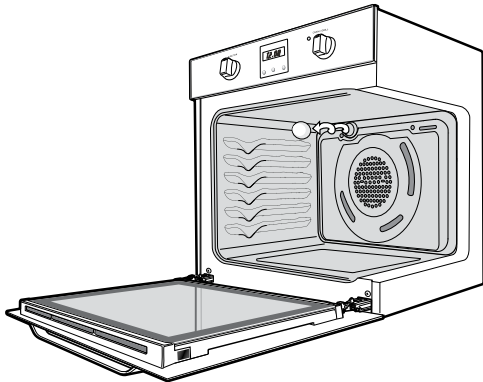

Removing and replacing the oven light

- Turn oven light glass anticlockwise to remove it for globe replacement.
- A special high temperature resistant globe should be used. This can be purchased from the Electrolux Customer Care Centre.

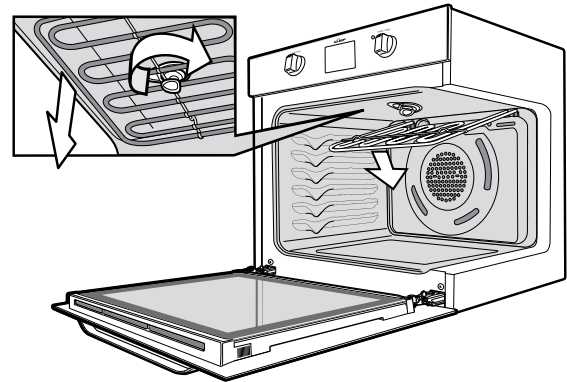

Rotating latch models

- Rotate latch 180°.

The element will drop down freely.



warning

Important:

Make sure the appliance is turned off before you remove or replace parts, to avoid the possibility of electric shock.

Releasing the grill element

Retaining wire models

We have designed the upper element with a hanger clip to help you reach your oven roof for cleaning.

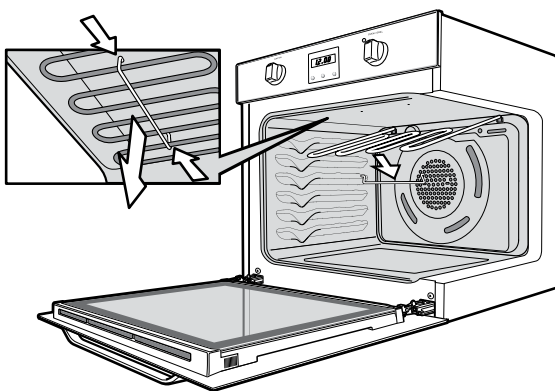

Retaining wire models

- Lift element up carefully.
- Push the sides of the clip together.

The element will drop down freely.

cleaning your oven door

warning

Do not lift the door by the handle. Rough handling will cause glass to break.

Removing the oven door

Your oven is equipped with a door that can be disassembled in order to clean all the panes of glass. Remove the door before cleaning.

- Open the door fully to access the hinges then rotate the 'stirrups' (highlighted in the image) on both hinges fully towards the oven.

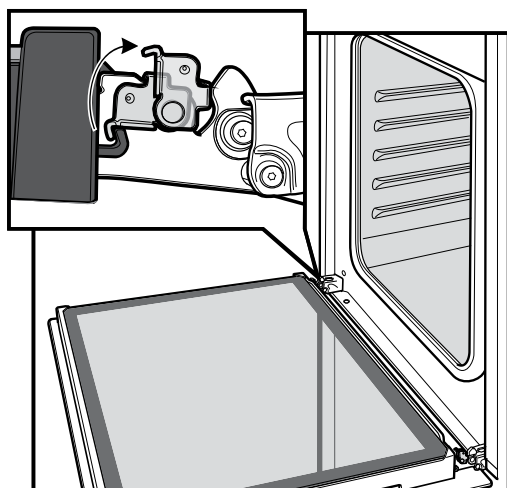

- Slowly close the oven door until it stops against the 'stirrups' (about 45°).

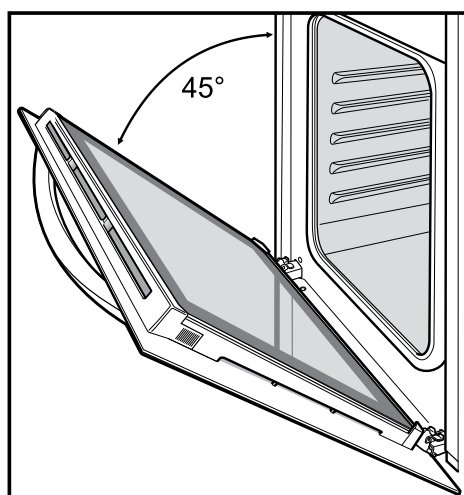

- Grasp the oven door with a hand each side of the door and remove it from the oven by pulling it towards you.

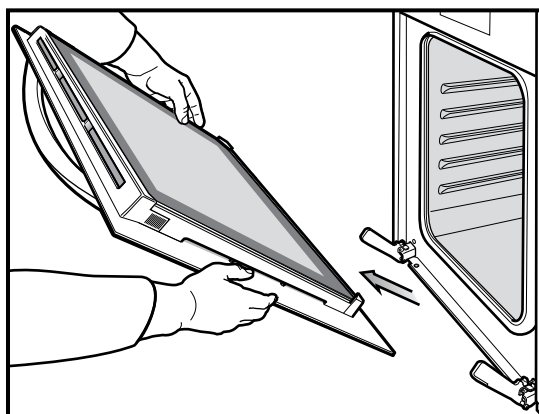

- Lay the oven door with the outer side facing downwards on something soft and flat (for example a blanket on a kitchen table) to prevent scratches.

Removing oven door top trim

- Take hold of the grid embossed sections of the door trim at each end and press inwards to release the clips. Remove the door trim by pulling it towards you.

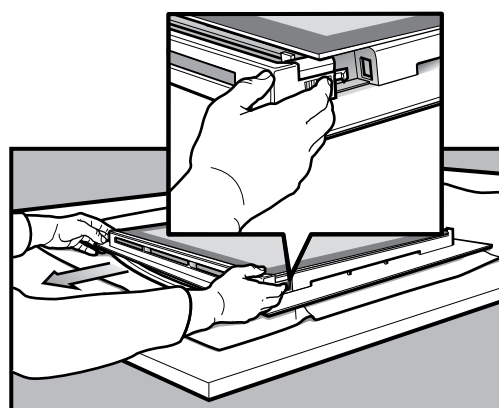

Removing door glass panels

warning

Rough handling, especially around the edges can cause the glass to break.

- Lift the black bordered glass panel out of the guide.
- Repeat this for the smaller clear glass panel (when fitted).

cleaning your oven door

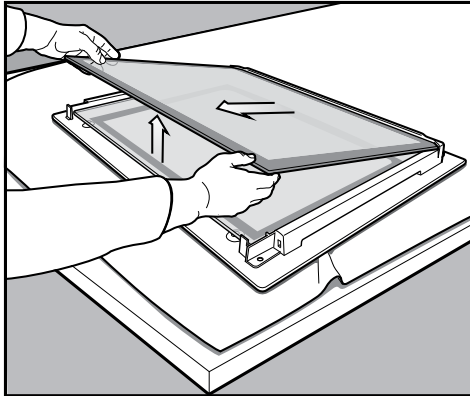

Cleaning door glass panels



warning

Do not use harsh abrasives on the glass panes as the reflective surface plays a role in the function of the oven. Do not place glass in dishwasher. Hand wash only with a soft cloth and warm soapy water. When dry polish with a soft cloth and ensure the glass is dry before reassembly.

Bottom trim (on selected models)

- The bottom trim may be removed for cleaning by snapping out and lifting away from the glass.

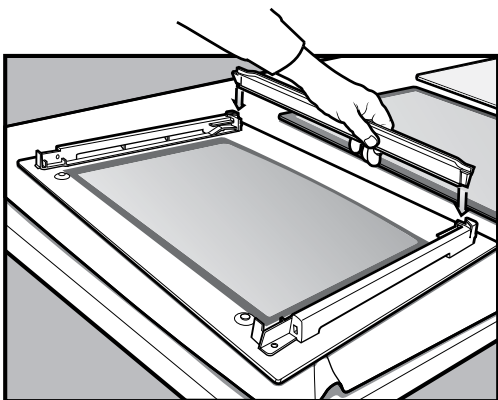

Re-assembling bottom trim

- Push down to “snap” each side of bottom trim back into door columns.

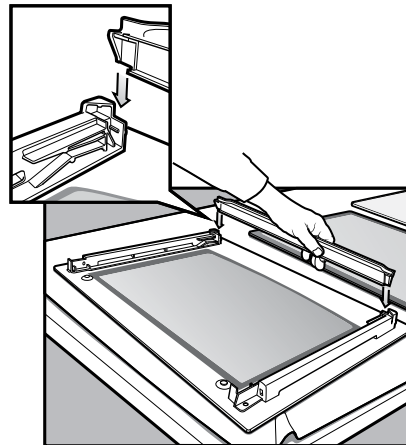

Re-assembling door glass panels

- Insert the smaller clear glass panel (when fitted) first from above and at an angle to the profile of the door.

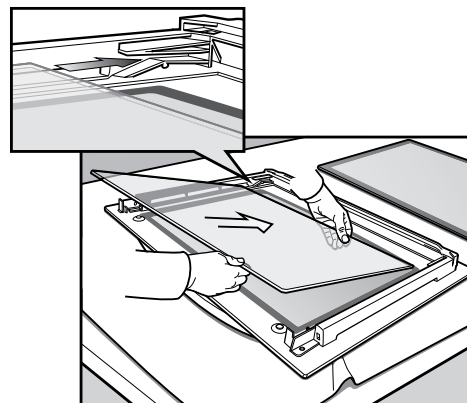

- Repeat for the black bordered glass panel ensuring the painted surface is facing to the downside.

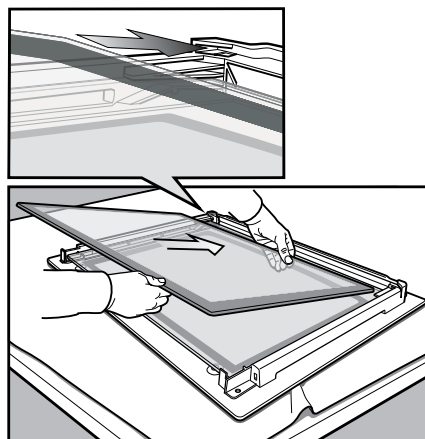

cleaning your oven door

Re-assembling top door trim

- Take hold of the top door trim at each side and position it to the inside edge of the glass.
- Push the trim down with its top edge over glass panel until the clip snaps in on each side of the trim.

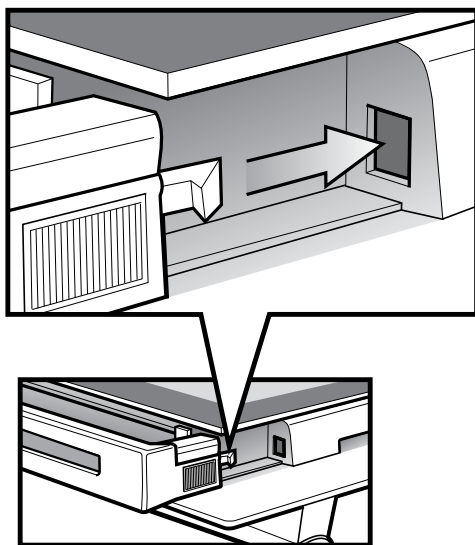

- Push the middle of the trim down to ensure it is straight and firm against the glass panel.

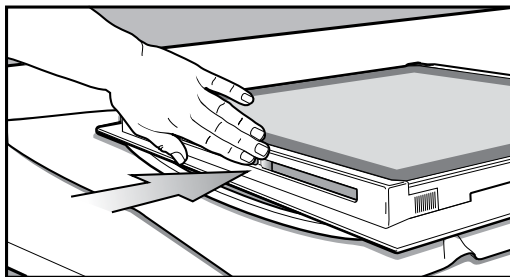

Fitting the oven door

- Take hold of the oven door with a hand on each side and with the door at an angle of 45°, position the recesses at the bottom of the door onto the hinge arms of the oven. Let the door slide down the hinge arms as far as it will go.

- Open the door fully to access the hinges then rotate the 'stirrups' (highlighted in the image) on both hinges back to their original positions.
The oven door may now be closed.

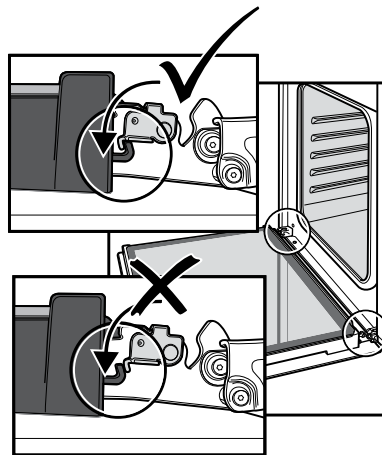

solving problems

Faults

If there is a problem with the oven and/or grill, please:

- Check the points listed below before calling for service. It may be possible to avoid a call by fixing the problem yourself – and so continue cooking.
- For cooking problems refer to page 14.

NOTE: We may charge for service even in the guarantee period if your problem is due to the causes listed below.

Data Plate

When you need information, service or replacement parts please:

- Tell us the 1. Model, 2. Model Number & 3. Serial Number shown on the data plate.

The data plate is visible when the oven or grill door is open.

Problem	Possible Cause
Oven or grill not working	<ul style="list-style-type: none">• Time of day not set.• Power not turned on.• Controls are incorrectly set.• Household fuse has blown or power supply is off.• Child-proof oven lock activated. (Refer to operating instructions). <p><i>NOTE: If the household fuse continues to blow, call the Electrolux Customer Care Centre.</i></p>
Oven light not working	<ul style="list-style-type: none">• Lamp blown or loose in socket.• Household fuse has blown. <p><i>NOTE: If the household fuse continues to blow, call the Electrolux Customer Care Centre.</i></p>
Oven not heating enough	<ul style="list-style-type: none">• Foil or trays on bottom of oven.
Oven not working	<ul style="list-style-type: none">• Timer is in "AUTO" mode. (Refer to timer operating instructions)• Household fuse has blown. <p><i>NOTE: If the household fuse continues to blow, call the Electrolux Customer Care Centre.</i></p>
Timer flashing on display	<ul style="list-style-type: none">• Power failure or interruption. <p><i>NOTE: Reset time of day and any cooking functions you were using. (Refer to TIMER operating instructions).</i></p>
Unit smoking when first used	<ul style="list-style-type: none">• Protective oils being removed.
Condensation building up	<ul style="list-style-type: none">• Reduce amount of water used in cooking. (Some condensation is normal)
Door cannot be replaced after removal	<ul style="list-style-type: none">• Stirrup not engaged properly.
Shelves tight in oven	<ul style="list-style-type: none">• Shelf not in correct orientation

When you need information, service or replacements please quote:

1. Model Number
2. Serial Number: You can find these on the data plate, which can be seen when the oven door is open. If you need more information, please contact the Customer Care Centre on 1300 363 640 (Australia – Centre is open 8.00am to 5.00pm Monday to Friday EST) Or 09 573 2384 (New Zealand – Centre is open 8.00am to 5.00pm Monday to Friday). Only authorised service centres should carry out servicing. Otherwise warranty may be void. If you have a warranty or spare parts enquiry, you should call the numbers listed on the back page.

installation

warning

USE AN AUTHORISED PERSON

As stated in the local municipal building codes and other relevant statutory regulations.

- Wiring connections must be in accordance with AS/NZS 3000 Wiring Rules and any particular conditions of the local authority.
- Refer to data plate for rating information and circuit diagram. The data plate is positioned behind the bottom of the oven door. The circuit diagram is positioned on the top panel of the appliance.
- An all pole disconnect functional switch should be provided near the appliance in an accessible position. Refer to AS/NZS 3000 clause 4.3.11
- Wiring should be protected against mechanical failure. Refer to AS/NZS 3000 clause 3.9
- A means of disconnection with a contact separation of at least 3mm must be supplied in the fixed wiring.
- To gain access to the mains connection terminals, remove the rear panel by unscrewing the 2 assembly screws.

NOTE: Where connection is made to a multi-phase 240V supply, the bridge piece should be removed from between the active connections.

warning

IMPORTANT: This appliance must be properly earthed.

- Do not lift the appliance by the door handles.
- Prepare the cupboard opening to match your appliance measurements. (See diagrams).
- Slide appliance into the cupboard, ensuring that the supply cable (where fitted) does not kink.
- To prevent tipping, use the screws supplied to secure your oven into the cupboard. Use just 2 screws for single cavity ovens and 4 screws for dual cavity. Remove the bottom door in dual cavity ovens to provide access to the bottom 2 screwing points. (See illustration page 23).
- For appliances fitted with a supply flexible cord, if the cord is damaged, it must be replaced by the manufacturer or its service agent or similarly qualified person in order to avoid a hazard. The plug must be accessible after installation.
- Where the appliance is built into a cabinet, the cabinet material must be capable of withstanding 70°C. Installation into low temperature tolerant cabinetry (e.g. vinyl coated)

may result in deterioration of the low temperature coating by discolouring or bubbling.

- If the appliance is installed adjacent to vinyl-wrapped surfaces, use an installation kit available from the vinyl-wrap supplier.
- Electrolux Home Products cannot accept responsibility for damage caused by installation into low temperature tolerant cabinets.
- After installation, test and ensure that the appliance operates correctly before handing it over to the customer.

warning

CAUTION: To avoid any potential hazard, you must follow our instructions below when you install your appliance. Failure to install the appliance correctly could invalidate any warranty or liability claims and lead to prosecution.

installation

Cabinet Construction for your appliance

For the best integration within a kitchen, install this appliance in a standard 600mm wide cupboard that gives a flush fit with the surrounding cupboard fronts (figure A).

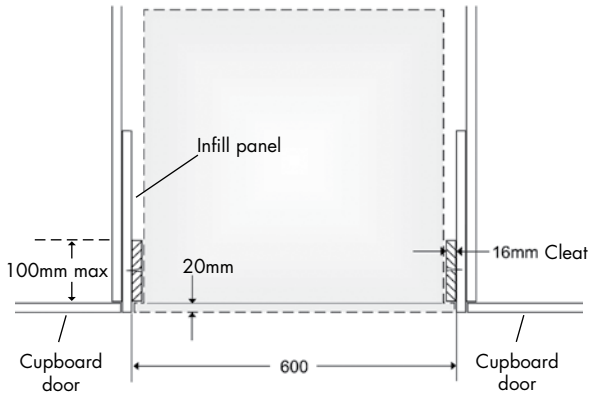

Figure A - Flush fit (top view)

A recess of 20 mm is ideal. It can also be installed using a proud fit with the surrounding cupboard (figure B).

NOTE: Your appliance must be mounted on a flat surface for the full width and depth of the product.

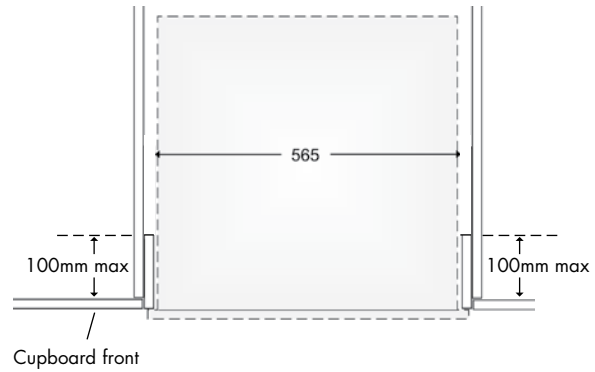

Figure B - Proud fit (top view)

Oven Dimensions

Underbench Oven	595 x 595 x 567mm (HxWxD)
Separate Grill Underbench Oven	725 x 595 x 567mm (HxWxD)
Separate Grill Wall Oven	888 x 595 x 567mm (HxWxD)

Underbench Ovens

Your underbench oven looks best when the control panel is directly under the benchtop. An upper infill panel may have to be added if the cooktop placed above the benchtop is too deep.

Refer to cooktop installation instructions for required clearance between cooktop and oven.

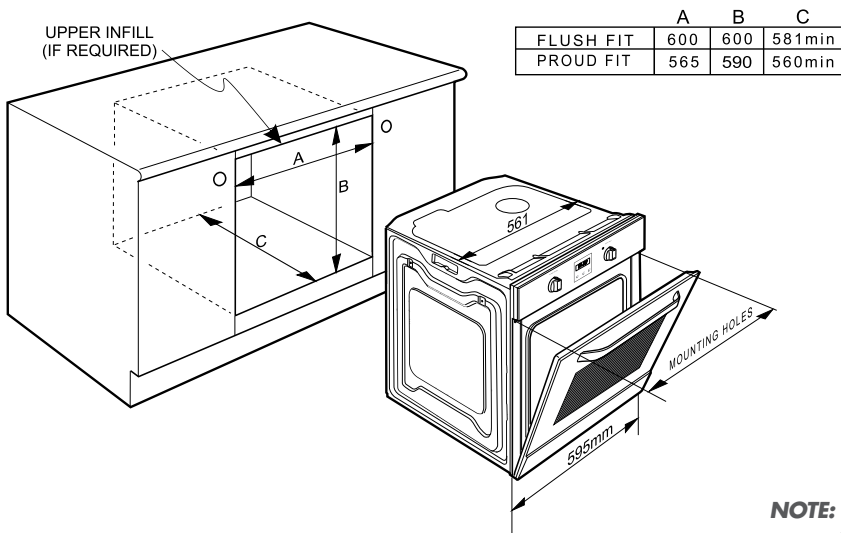

NOTE: If a powerpoint is fitted it must be accessible with the appliance installed.

installation

Separate Grill Underbench Ovens

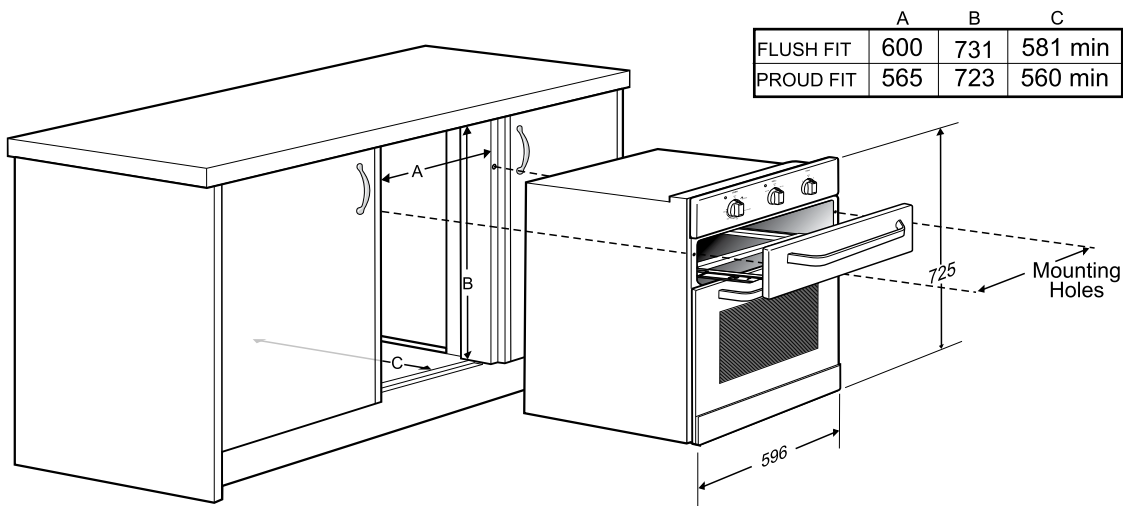

Recommended Cabinet Design

NOTE TO INSTALLER: For Separate Grill Underbench Installations where a Cooktop is installed directly above the appliance, a minimum clearance distance of 10mm must be allowed for between the bottom of the cooktop & the top of the Separate Grill Underbench Oven.

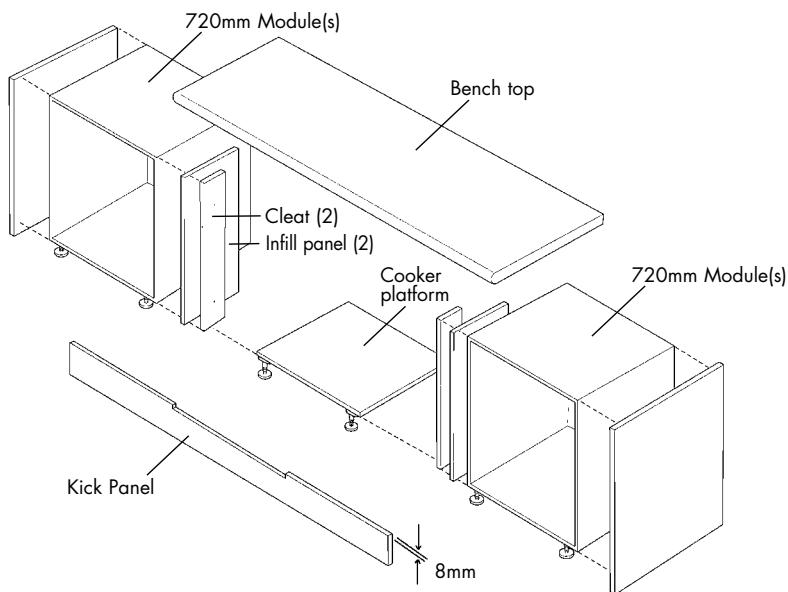

Supporting shelf 8mm below door line to give perfect alignment of cooker & cupboard (kickboard notched to suit).

installation

Separate Grill Wall Ovens

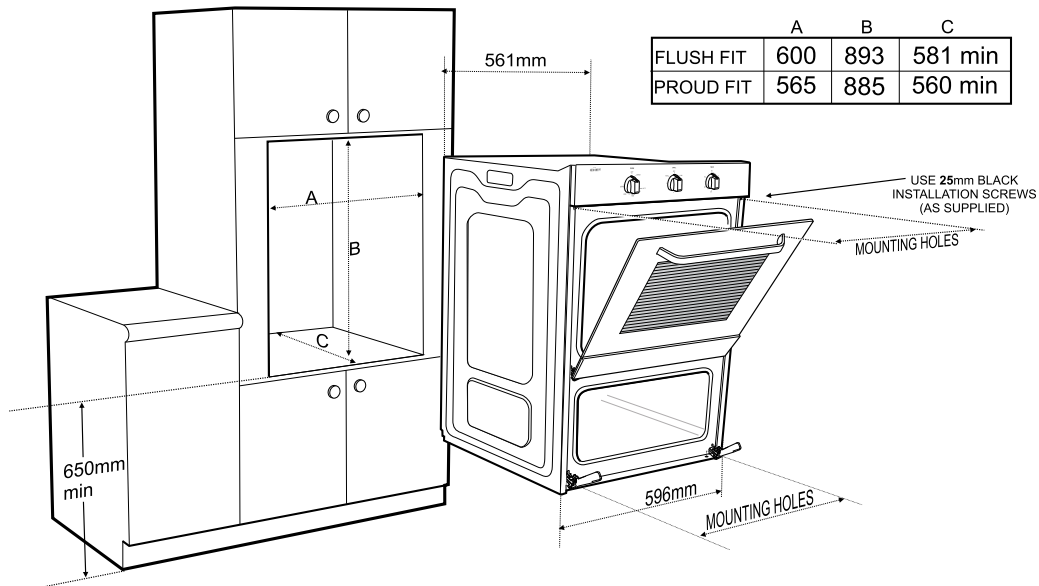

Hard Wiring Detail

1. Remove terminal cover plate from rear panel of appliance.
2. Fit wires through hole in cover plate and make connections to terminals.
3. Engage wires into plastic clip. Secure plastic clip with two long silver screws (supplied in separate bag).
4. Replace cover plate onto rear panel.

NOTE: Double oven (Model PDP794). This product is supplied with two optional termination points. Only one termination point is required to be connected.

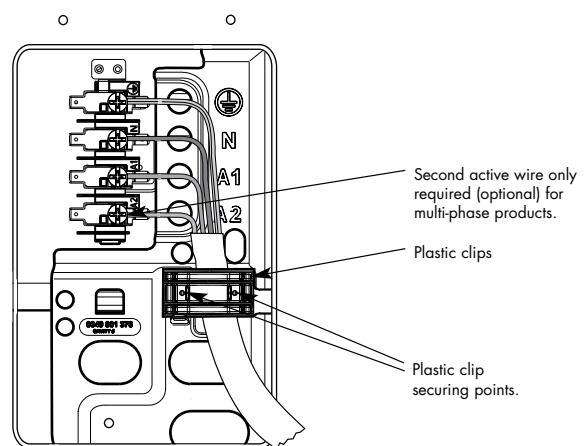

Electrolux Warranty

FOR SALES IN AUSTRALIA AND NEW ZEALAND
APPLIANCE: BUILT-IN COOKING APPLIANCES

This document sets out the terms and conditions of product warranties. It is an important document. Please keep it with your proof of purchase documents in a safe place for future reference should you require service for your appliance.

General Terms and Conditions

- In this warranty
 - 'Electrolux' means Electrolux Home Products Pty Ltd ABN 51 004 762 341 in respect of Appliances purchased in Australia and Electrolux (NZ) Limited in respect of Appliances purchased in New Zealand;
 - 'Appliance' means any Electrolux product purchased by you accompanied by this document;
 - 'Warranty Period' means
 - where you use the Appliance for personal, domestic or household purposes in Australia the period of '24' months and in New Zealand the period of '24' months;
 - where you use the Appliance for commercial purposes, in Australia the period of '3' months and in New Zealand the period of '3' months, (if the period stated is 0 months you are not covered by this product warranty) following the date of original purchase of the Appliance;
 - 'you' means the purchaser of the Appliance not having purchased the appliance for re-sale, and 'your' has a corresponding meaning.
- This warranty only applies to Appliances purchased and used in Australia or New Zealand and is in addition to (and does not exclude, restrict, or modify in any way) any non-excludable statutory warranties in Australia or New Zealand.
- Electrolux warrants that, when dispatched from an Electrolux warehouse, the Appliance is free from defects in materials and workmanship for the Warranty Period.
- During the Warranty Period Electrolux or its Authorised Service Centre will, at no extra charge if your appliance is readily accessible without special equipment, and subject to these terms and conditions, repair or replace any parts which it considers to be defective. You agree that any replaced Appliances or parts become the property of Electrolux. This warranty does not apply to light globes, batteries, filters or similar perishable parts.
- Parts and Appliances not supplied by Electrolux are not covered by this warranty.
- Where you are within an Electrolux service area, this warranty covers the cost of transport of the Appliance to and from Authorised Service Centres of Electrolux and travelling costs for representatives of the Authorised Service Centre to and from your home or business. If you are outside an Electrolux service area, you will bear these costs. For information about whether you are within an Electrolux service area, please phone 13 13 49 in Australia, or 0800 10 66 10 in New Zealand.
- Proof of purchase is required before you can make a claim under this warranty.

- You may not make a claim under this warranty unless the defect claimed is due to faulty or defective parts or workmanship. Electrolux is not liable in the following situations (which are not exhaustive):
 - The Appliance is damaged by:
 - accident
 - misuse or abuse, including failure to properly maintain or service
 - normal wear and tear
 - power surges, electrical storm damage or incorrect power supply
 - incomplete or improper installation
 - incorrect, improper or inappropriate operation
 - insect or vermin infestation.
 - The Appliance is modified without authority from Electrolux in writing.
 - The Appliance's serial number or warranty seal has been removed or defaced.
 - The Appliance was serviced or repaired by anyone other than Electrolux or its Authorised Service Centres.
- This warranty, the contract to which it relates and the relationship between you and Electrolux are governed by the law applicable in the Australian State where the Appliance was purchased or the law applicable in New Zealand if the Appliance was purchased in New Zealand. Where the Appliance was purchased in New Zealand for business purposes the Consumer Guarantee Act does not apply.

Limitation of Liability

- To the extent permitted by law:
 - Electrolux excludes all warranties other than as contained in this document;
 - Electrolux shall not be liable for any loss or damage whether direct or indirect or consequential arising from your purchase, use or non-use of the Appliance.
- Provisions of the Trade Practices Act and State consumer legislation in Australia, and the Consumer Guarantees Act, the Sale of Goods Act and the Fair Trading Act in New Zealand, imply warranties or conditions, or impose obligations, upon Electrolux which cannot be excluded, restricted or modified. To the extent permitted by law, the liability of Electrolux (if any) arising out of or in relation to the Appliance or any services supplied by Electrolux shall be limited (where it is fair and reasonable to do so),:
 - in the case of Appliances, at its option, to the replacement or repair of the Appliances or the supply of equivalent products or the payment of the cost of replacing the Appliances or having the Appliances repaired or of acquiring equivalent Appliances. Upon being replaced, parts and Appliances become the property of Electrolux; or
 - in the case of services, at its option, to the supply of the services again or the payment of the cost of having the services re-supplied; and in the case of Appliances or services supplied in New Zealand, loss or damage whether direct or indirect or consequential that is reasonably foreseeable.

Privacy

You acknowledge that in the event that you make a warranty claim it will be necessary for Electrolux and its Authorised Service Centres to exchange information in relation to you to enable Electrolux to meet its obligations under this warranty.

Important Notice

Before calling a Service Technician please check carefully the operating instructions, service booklet and the warranty terms and conditions.

<p>FOR SERVICE or to find the address of your nearest state service centre in Australia PLEASE CALL 13 13 49 For the cost of a local call (Australia only)</p>	<p>SERVICE AUSTRALIA  ELECTROLUX HOME PRODUCTS www.electrolux.com.au</p>	<p>FOR SPARE PARTS or to find the address of your nearest state spare parts centre in Australia PLEASE CALL 13 13 50 For the cost of a local call (Australia only)</p>
<p>FOR SERVICE or to find the address of your nearest authorised service centre in New Zealand FREE CALL 0800 10 66 10 (New Zealand only)</p>	<p>SERVICE NEW ZEALAND  ELECTROLUX HOME PRODUCTS www.electrolux.co.nz</p>	<p>FOR SPARE PARTS or to find the address of your nearest state spare parts centre in New Zealand FREE CALL 0800 10 66 20 (New Zealand only)</p>

like to know more?

For further information on all appliances, or to obtain detailed dimension and installation information, call into your Retailer, phone or email our Customer Care team or visit our website:

Australia

phone: 1300 363 640
fax: 1800 350 067
email: customercare@electrolux.com.au

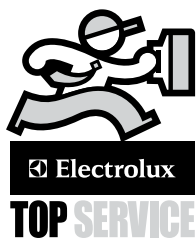

Top service

Top Service encompasses the after sales service provided by The Electrolux Group to consumers including delivery, home service and spare parts.

**We are part of the Electrolux family.
Share more of our thinking at www.electrolux.com**

© 2010 Electrolux Home Products Pty Ltd ABN 51 004 762 341

Print code: CMAN_BICOOK_UM Issue Date: May10

Part No. XXXXX