



**Item # 211-4758 Model # M27BC**

**Item # 211-4759 Model # M27BCTB**

**Item # 211-4760 Model # M27BCTR**

**Item # 211-4761 Model # M27BCW**

## **USE AND CARE GUIDE**

### **27 IN 2-Door Base Cabinet**

Questions, problems, missing parts?

Before returning to the store, call

1-866-441-5080

9 a.m – 5 p.m., CST, Monday-Friday

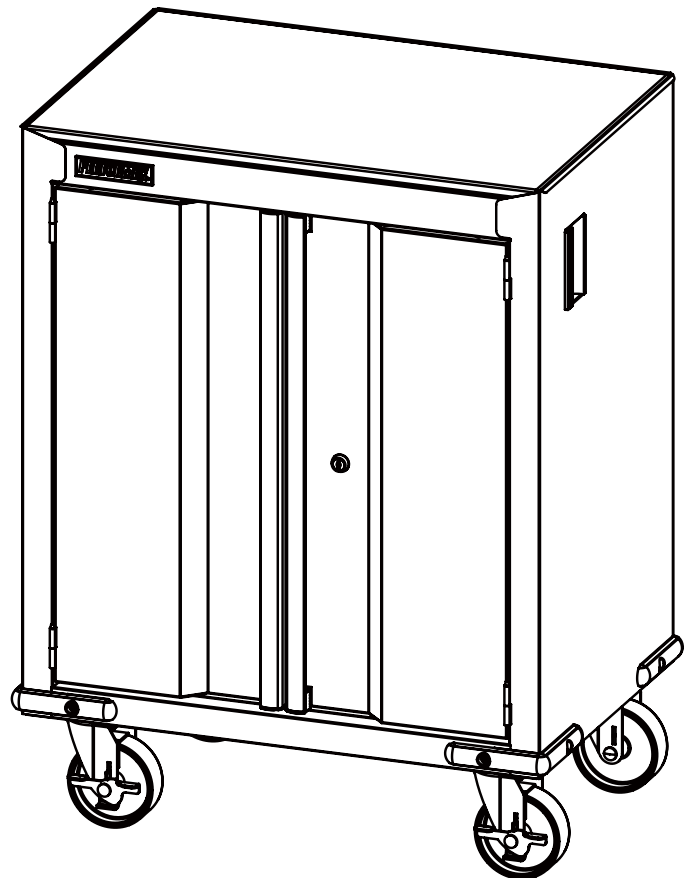

# Table of Contents

Table of Contents.....	2	Assembly .....	5
Safety Information .....	2	Operation .....	6
Warranty .....	3	Maintenance.....	7
Specifications .....	3	Replacement Parts .....	7
Package Contents.....	3-4		

# Safety Information

1. Do not pull this unit, push it when moving.
2. Use the brakes when this product is not being moved. This prevents the product from rolling.
3. Secure this product properly before moving it with a forklift.
4. Do not tow the product with power equipment.
5. Do not alter this product in any manner. For example, do not weld external lock bars or attach electrical equipment.



**CAUTION:** Lock the door before moving this product. The doors could come open and make the product unstable and tip, which may cause personal or product damage.



**CAUTION:** Do not attach or mount this product to a vehicle or mobile trailers. This may cause personal injury or product damage. Mounting this product to any vehicle or mobile trailers in any manner will void warranty.



**CAUTION:** Do not stand on this product. You may fall which may cause personal injury or product damage.



**CAUTION:** Keep the product on level surfaces. The product may become unstable and tip if stored or moved on an unlevel surface, which may cause personal injury or product damage.

# Limited Lifetime Warranty

PERFORMAX® Tool Cabinets and Chests are warranted to be free from defects in materials and workmanship under normal use for the lifetime that you own the product. If any part of the product is found to be defective during normal use, the defective product or part will be replaced at our discretion. This warranty does not cover products that are damaged through accident, abuse, misuse, commercial/industrial applications or neglect. This warranty also does not cover any losses, injuries or costs including indirect, incidental or consequential damages. This warranty may not be transferred or sold. When requesting warranty service please call 1-866-441-5080 and have the model number, cash register receipt and the date of purchase available when you call. If the product is defective, we will replace the defective part at no cost to you. Some states do not allow the exclusion or limitation of incidental damages, so the above limitations or exclusions may not apply to you. This warranty gives you specific legal rights and you may have other rights, which vary from state to state.

# Specifications

Maximum weight per (shelf )	100 lbs.
Casters support up to	600 lbs.



**NOTE:** Begin product assembly close to the final intended location of your cabinet. This product is heavy and may be difficult to move after assembly.

# Package Contents

## HARDWARE INCLUDED



**NOTE:** Hardware not shown to actual size.

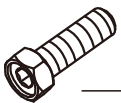

AA



BB



CC

Part	Description	Quantity
AA	M8 x 20 bolt	16
BB	M6 x 16 bolt	8
CC	Hex key	1

# Package Contents (continued)



**NOTE:** Cabinet Keys are inside shelf.

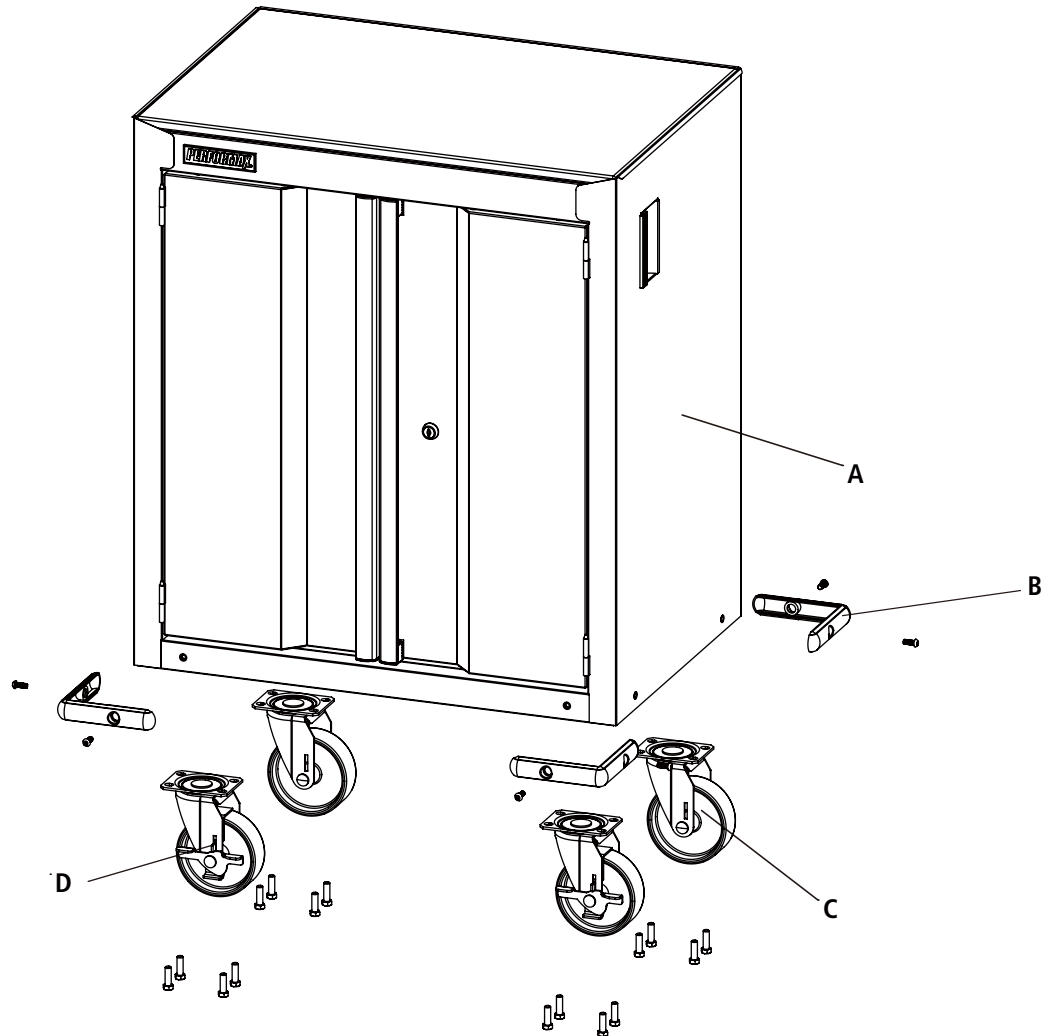

Part	Description	Quantity
A	Cabinet	1
B	Bumper	4
C	Swivel caster without brake	2
D	Swivel caster with brake	2

# Assembly



**CAUTION:** Two people are recommended for assembly.

## 1 Attaching the casters

- Be sure the doors are locked and lay the cabinet (A) on its back. Use packaging material to protect the finish.
- Attach the swivel casters with brake (D) on the front of the unit inserting four bolts (AA) per caster into the cabinet (A).
- Tighten with supplied hex key (CC).
- Attach the swivel casters without brake (C) on the back of the unit inserting four bolts (AA) per caster into the cabinet (A).
- Return the cabinet (A) to its upright position.



**CAUTION:** Do not over tighten the bolts.

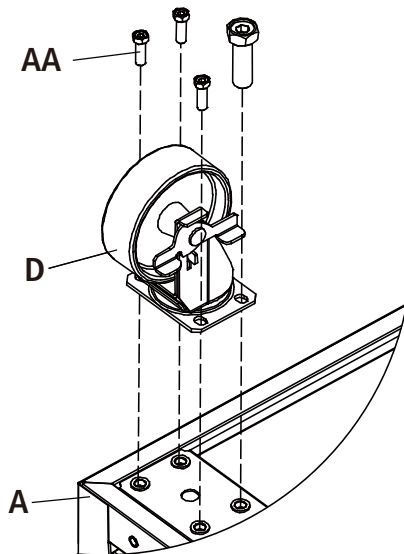

## 2 Attaching the bumpers

- Position the bumpers (B) over the corner holes. Insert 2 bolts (BB) into bumper holes and tighten with supplied Hex key (CC). Do not over tighten.

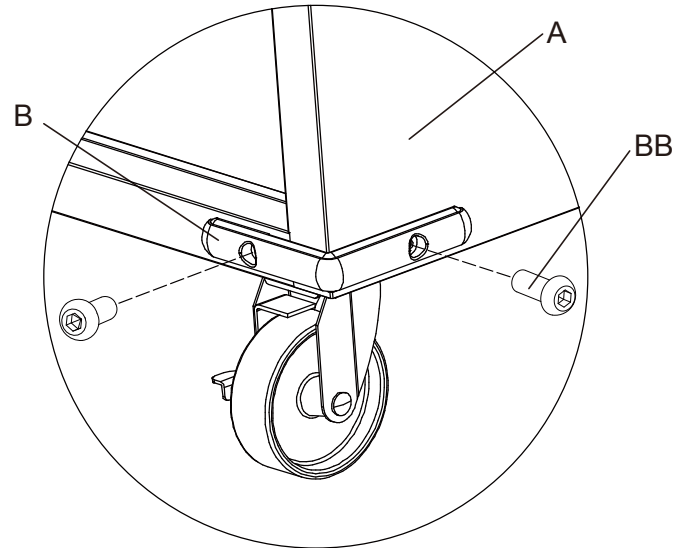

# Operation

## 1 Removing the sliding tray

- Fully extend the empty sliding tray.
- Push up the one release lever while pulling down on the other release lever.
- Pull the tray outward until it is released from the tray slide.

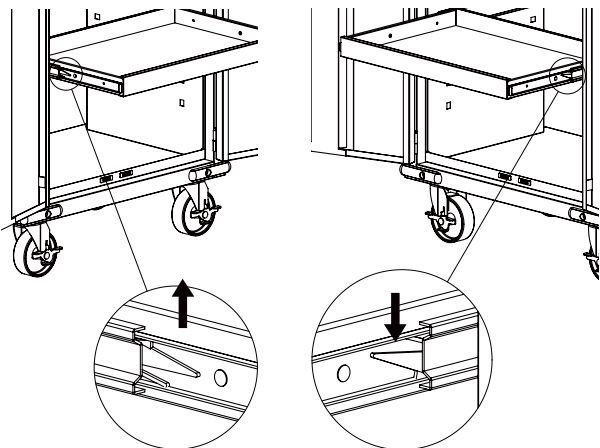

## 2 Sliding tray height adjustment

- With the sliding tray removed, push up at the front of the outer slide to release the clip from the side panel groove and then pull outward to remove.
- Determine the desired height of your shelf.
- Insert the back clip of the outer slide, and then push down to lock the front clip into the groove of the side panel.

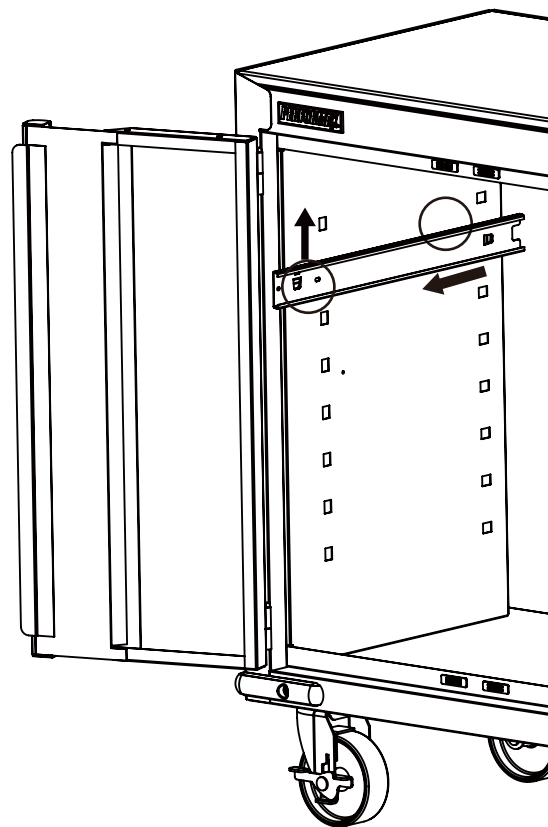

## 3 Re-inserting the sliding tray

- Extend the tray slides.
- Insert the brackets on each side of the tray into the slots in the slides, being careful that they are properly positioned.
- Once properly inserted, completely close the tray to set the slides in their proper positions.

# Maintenance

## 1 Caster maintenance

- Grease the casters annually using high-quality bearing grease.

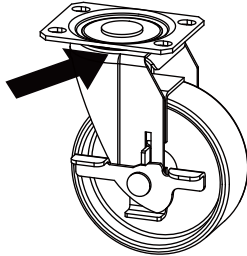

## 2 Drawer maintenance

- Lubricate the slides semi-annually with high-quality bearing grease.

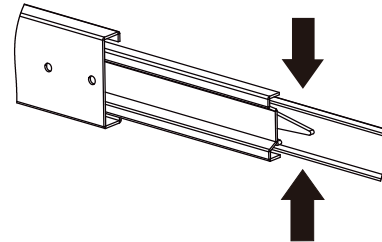

- Periodically clean the drawer fronts, drawer trim, and other surfaces with a mild detergent and water.
- Remove grease and oil with a standard nonflammable cleaning fluid.

# Replacement Parts

For assistance with replacement parts please call 1-866-441-5080.

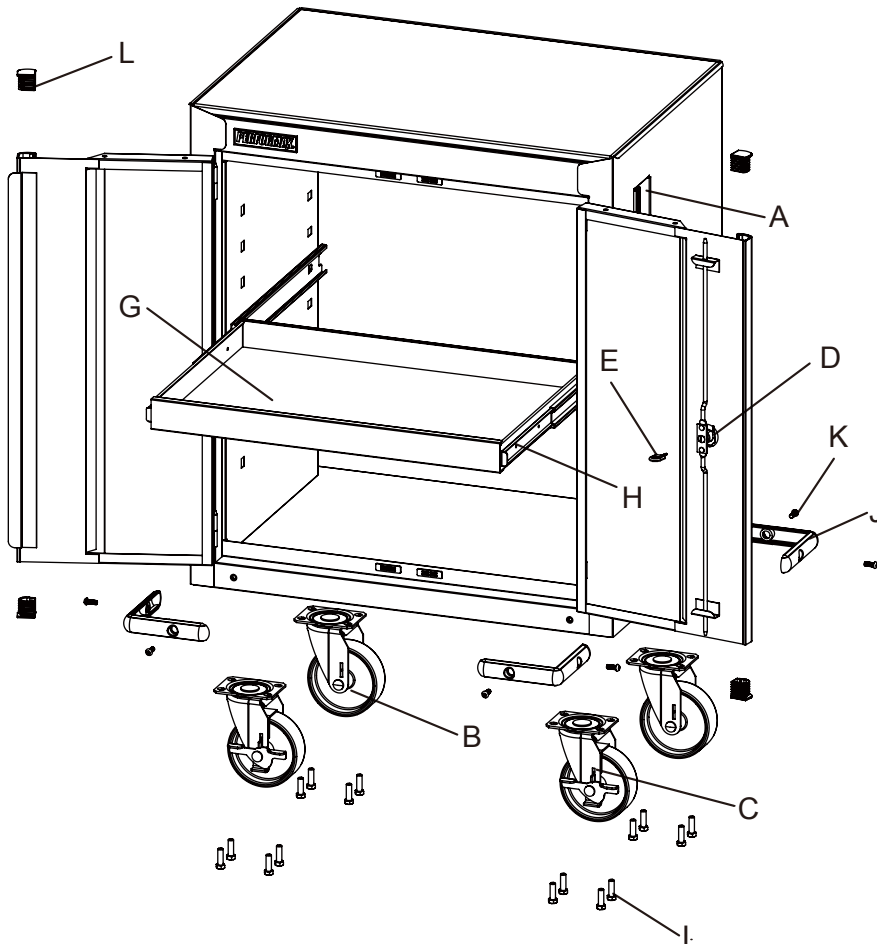

Part	Description	Quantity
A	Cabinet Handle	2
B	Swivel Caster without brake	2
C	Swivel Caster with brake	2
D	Lock	1
E	Key	2
F	Badge	1
G	Drawer Liner	1
H	Drawer Slide	2
I	Caster Bolt	16
J	Bumper	4
K	Bumper Bolt	8
L	Plastic Cap	4