



**BUILT-IN COOKING APPLIANCES
OWNER'S MANUAL**

**Underbench, separate grill,
duo and double ovens**

POR663, PORS663L/R, POR667, POR668,
PORS668L/R, POR783, POR788, PPR776, PGR657,
PGR659, PXR688, PXR698, PDR790, PDR794

 **Westinghouse**
made for modern families

congratulations

Congratulations and thank you for choosing our product. We are sure you will find your new appliance a pleasure to use and a great asset to your cooking. Before you use the appliance, we recommend that you read through the whole user manual which provides the description of the cooking appliance and its functions.

To avoid the risks that are always present when you use a gas appliance, it is important that the appliance is installed correctly and that you read the safety instructions carefully to avoid misuse and hazards. For future reference, please store this booklet in a safe place.

Please read the user manual carefully and store in a handy place for later reference. The symbols you may see in this booklet have these meanings:

CONDITIONS OF USE

This appliance is intended to be used in household and similar applications such as:

- Staff kitchen areas in shops, offices and other working environments
- Farm houses
- By clients in hotels, motels and other residential type environments
- Bed and breakfast type environments

warning

This symbol indicates information concerning your personal safety

caution

This symbol indicates information on how to avoid damaging the appliance

important

This symbol indicates important information

tips & information

This symbol indicates tips and information about use of the appliance

environmental tips

This symbol indicates tips and information about economical and ecological use of the appliance

Meanings of symbols used in this manual are shown below:

 This symbol indicates never to do this

 This symbol indicates always do this

Record model and serial number here:

Model:

Serial number:

| | |
|---|-----------|
| Description of your appliance | 4 |
| POR663, PORS663L/R, POR667, POR668, PORS668L/R, POR783, POR788, PPR776 | 4 |
| PGR657, PGR659, PXR688, PXR698, PDR790, PDR794 | 5 |
| Before operating your appliance for the first time .. | 6 |
| Setting the time | 6 |
| Preparing your appliance for the first time | 6 |
| Installing your oven accessories | 7 |
| Catalytic liners | 7 |
| Side racks | 7 |
| Shelves and trays | 8 |
| Side opening door features | 8 |
| Using your oven | 9 |
| Understanding your oven functions | 9 |
| Cooling/venting fan | 11 |
| Condensation | 11 |
| Operating your oven temperature selector | 11 |
| Pre-heating your appliance | 11 |
| Setting temperatures | 12 |
| Using your cooktop | 13 |
| Utensils | 13 |
| Cooking Do's and Don'ts | 14 |
| Cleaning your ceramic hotplate | 14 |
| Cooking hints | 15 |
| Cooking with your timer | 16 |
| 2-hour "Auto Off" timer | 16 |
| Electronic clock | 16 |
| POR783 programmable controller | 17 |
| Cooking guide | 19 |
| Oven shelf location | 19 |
| Choosing the best oven settings | 19 |
| Roasting meat | 20 |
| Roasting poultry and fish | 20 |
| Grilling guide | 23 |
| Grilling hints | 23 |
| Guide to better grilling | 23 |
| Fan grill | 23 |
| Dealing with cooking problems | 24 |
| Cleaning your appliance | 25 |
| Enamel | 25 |
| Stainless Steel | 25 |
| Glass | 25 |
| Oven | 25 |
| Grill | 25 |
| Cleaning your oven accessories | 25 |
| Releasing the grill element | 25 |
| Cleaning your oven door (side opening door models) | 29 |
| Catalytic liners (where fitted) | 27 |
| Solving problems | 32 |
| Installation | 33 |
| Cabinet Construction | 34 |
| Hard Wiring details | 37 |
| Door removal | 28 |
| Cooktop cut-out dimensions (combo models) | 37 |
| Door conversion for side opening door | 38 |

safety and warning instructions

Read the following carefully to avoid an accident.

General warnings

- This appliance is not intended for use by persons (including children) with reduced physical, sensory or mental capabilities, or lack of experience and knowledge, unless they have been given supervision or instruction concerning use of the appliance by a person responsible for their safety. Children should be supervised to ensure that they do not play with appliance.
- During use, this appliance becomes hot. Care should be taken to avoid touching hot surfaces, e.g. oven door, heating elements.
- This appliance must not be used as a space heater.
- In order to avoid a fire, the appliance must be kept clean and vents kept unobstructed.
- Do not spray aerosols in the vicinity of the appliance during operation.
- Do not store flammable materials in or under the appliance, e.g. Aerosols.
- Accessible parts will become hot when in use. To avoid burns and scalds children should be kept away.
- Do not line the bottom of the oven or grill with foil or cookware. It will damage the enamel.

Grill

- The grill door must be left fully open whilst grilling in a separate grill wall oven.
- The grill drawer must be left approximately two finger widths ajar whilst grilling in a separate grill underbench oven.
- Always turn the grill off immediately after use as fat left there may catch fire.
- Do not cover the insert with foil, as fat left there may catch fire.
- Always keep the grill dish clean as any fat left may catch fire.
- Do not leave the grill on unattended.
- To avoid a fire, ensure that grill trays and fittings are always inserted into the appliance in accordance with the instructions.
- Do not place thick portions of food under the grill. Foods may curl, catch and ignite.
- Accessible parts may become hot when grill is in use. Children should be kept away.

Oven

- During use the appliance becomes hot. Care should be taken to avoid touching the hot surfaces inside the oven.
- Switch the appliance off before removing the oven light glass for globe replacement.
- To avoid an accident, ensure that oven shelves and fittings are always inserted into the appliance in accordance with the instructions.
- Do not use the door as a shelf.
- Do not push down on the open oven door.

Cooktops

- Do not allow pots to boil dry, as damage to both pan and cooktop may result.
- Do not operate the cooktop for an extended period of time without a utensil on the hot plate.
- Do not allow large cookware to overhang the cooktop onto the adjacent benchtop. This will cause scorching to the benchtop surface.
- If the ceramic glass is accidentally cracked, switch off the appliance to avoid the possibility of electric shock.
- Do not place heat resistant mats, wire mats or aluminium foil under pots or pans.
- Do not cook food directly on the ceramic glass surface.
- Do not use round bottom woks, wok stands or similar utensils that could lead to over heating of hotplates and possible damage to the cooking surface.

Installation, cleaning and servicing

- An authorised person must install this appliance.
- Before using the appliance, ensure that all packing materials are removed from the appliance.
- In order to avoid any potential hazard, the enclosed installation instructions must be followed.
- Ensure that all specified vents, openings and airspaces are not blocked.
- Where the appliance is built into a cabinet, the cabinet material must be capable of withstanding 70°C
- Only authorised personnel should carry out servicing. (Certificate of Compliance to be retained)
- Always ensure the appliance is switched off before cleaning or replacing parts.
- Do not use steam cleaners, as this may cause moisture build up.
- Always clean the appliance immediately after any food spillage.
- To maintain safe operation, it is recommended that the product be inspected every five years by an authorised serviceperson.

This appliance must be earthed.



important

IMPORTANT – Check for any damage or marks.

If you find the appliance is damaged or marked, you must report it within 7 days if you wish to claim for damage/ marks under the manufacturer's warranty. This does not affect your statutory rights.



environmental tips

INFORMATION ON DISPOSAL FOR USERS

- Most of the packing materials are recyclable. Please dispose of those materials through your local recycling depot or by placing them in appropriate collection containers.
- If you wish to discard this product, please contact your local authorities and ask for the correct method of disposal.

MODEL POR663 and PORS663L/R

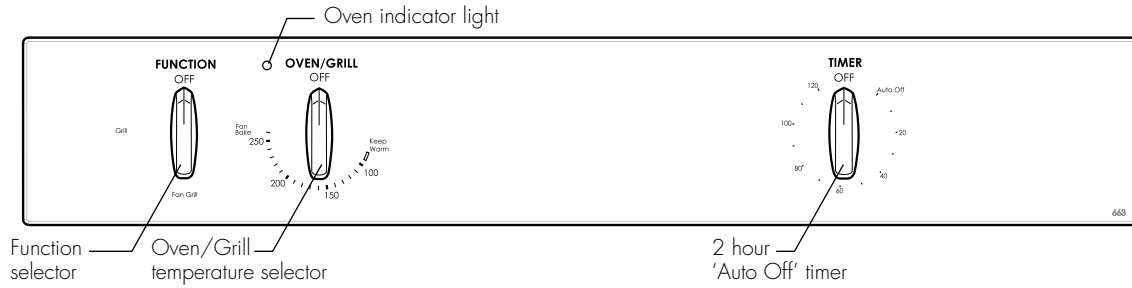

MODEL POR667

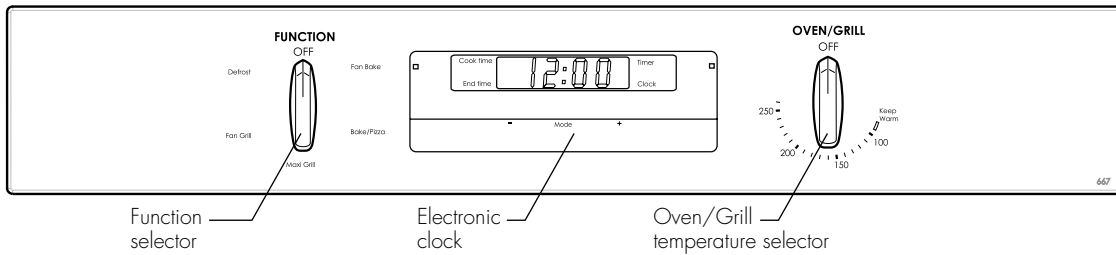

MODEL POR668 and PORS668L/R

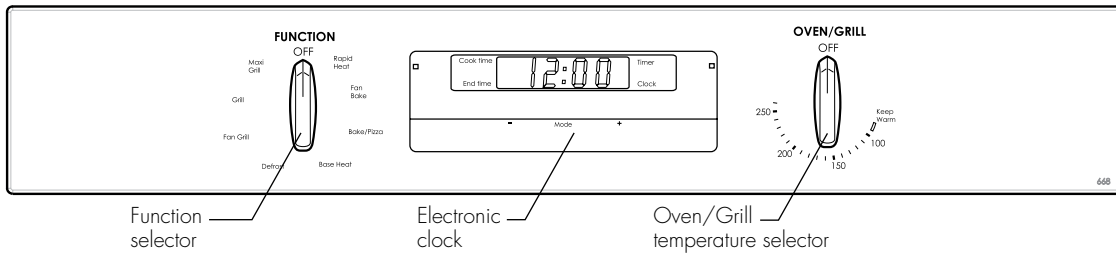

MODEL POR783

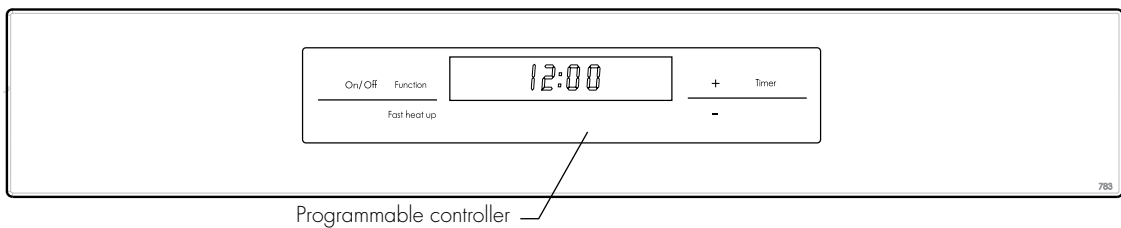

MODEL PPR776

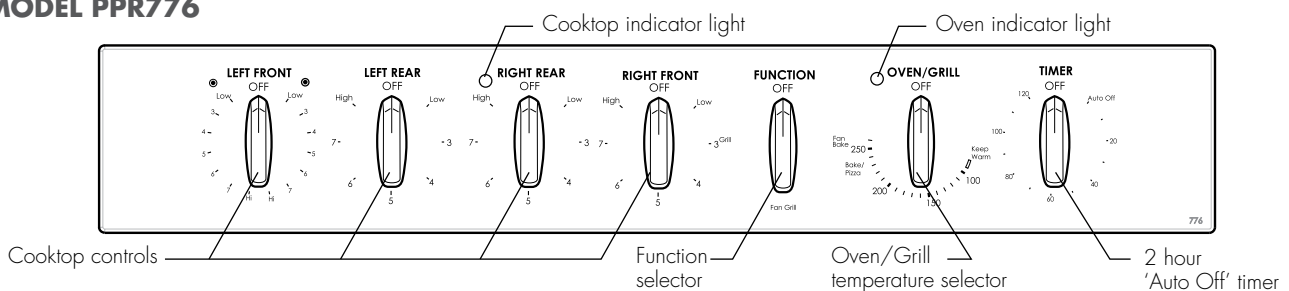

MODEL POR788

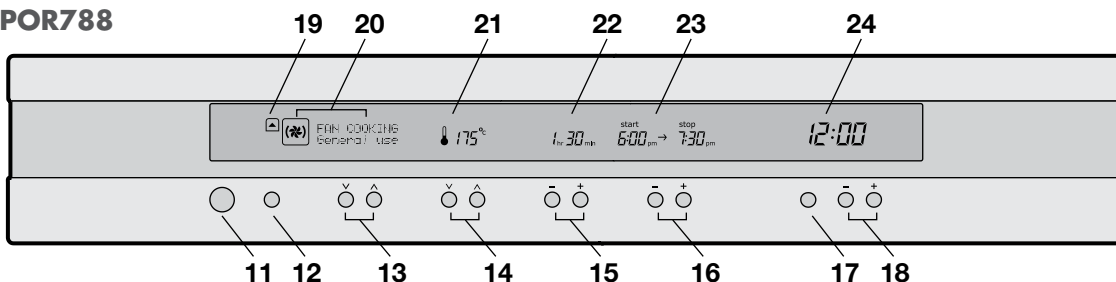

- 11 ON/OFF button
- 12 Upper/lower oven selector (EU663CS & ED663CS) Pyro accept button (EP663CS only)
- 13 Cooking function selectors
- 14 Temperature selectors

- 15 Cook time selectors
- 16 Start/stop time selectors
- 17 Timer button
- 18 Set clock buttons
- 19 Upper or lower oven display

- 20 Cooking function display
- 21 Temperature display
- 22 Cook time display
- 23 Start/stop time display
- 24 Clock

MODEL PGR657

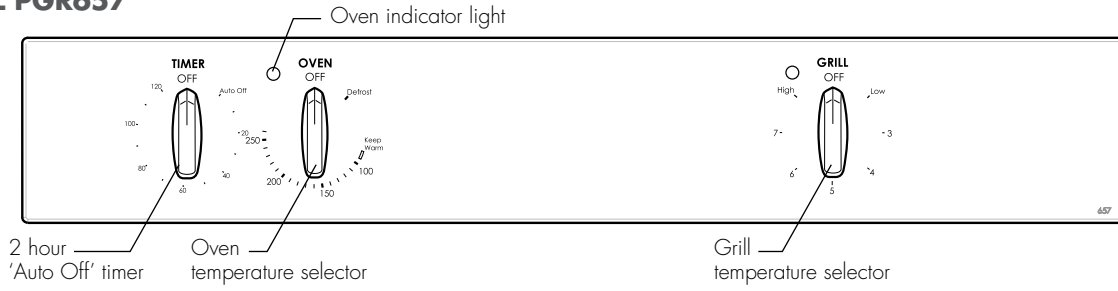

MODEL PGR659

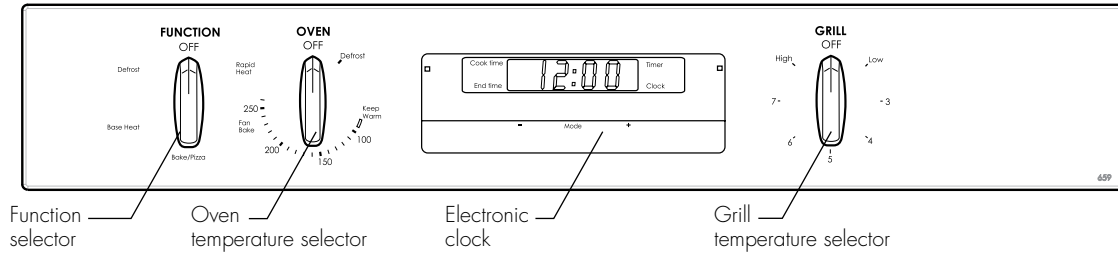

MODEL PXR688

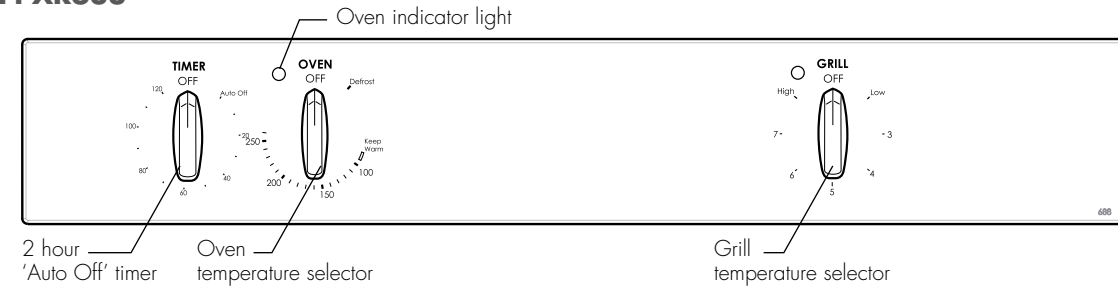

MODEL PXR698

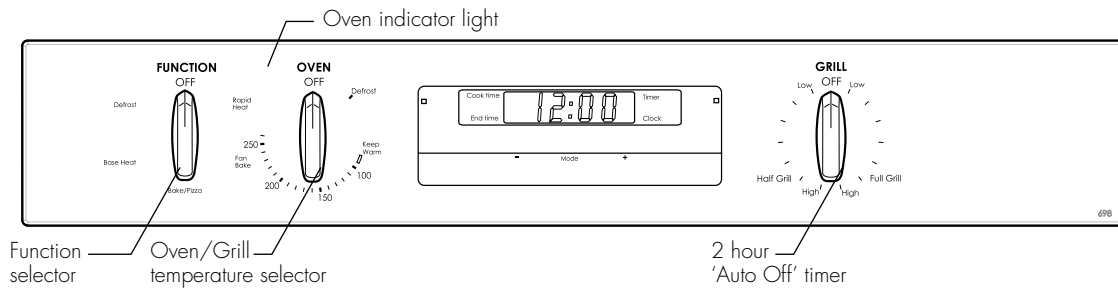

MODEL PDR790

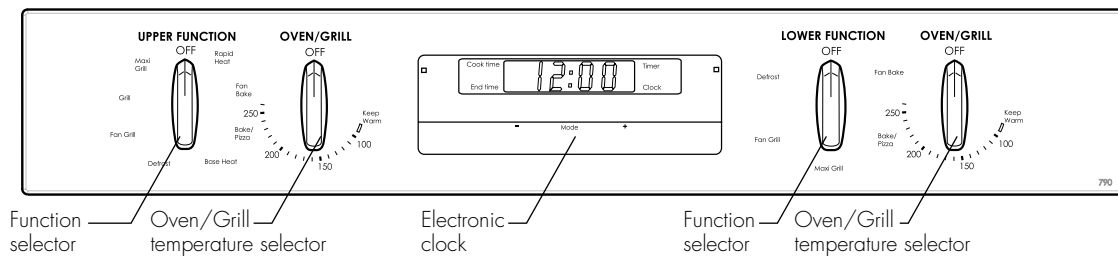

MODEL PDR794

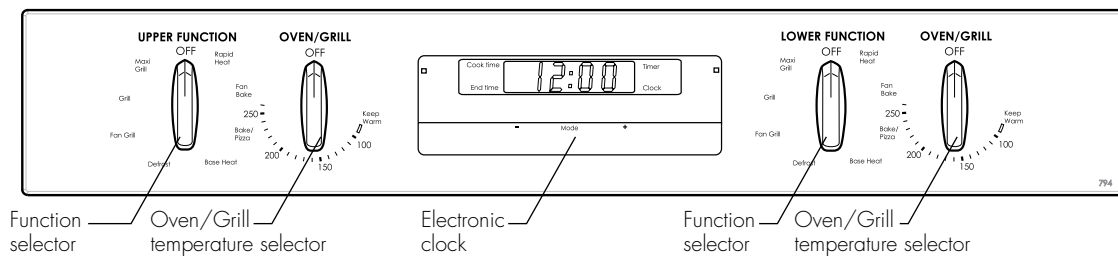

setting the time

If you have purchased a model fitted with an electronic or programmable timer, you **must** set the time of day before you can operate your appliance.

Electronic Clock

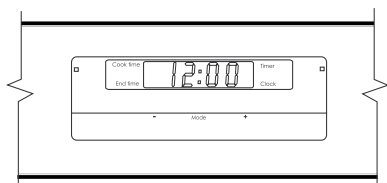

- After the appliance has been electrically connected "12.00" will be displayed and the "clock" indicator will flash.
- To set the time of day, press – or +. 5 seconds after the last change, the "clock" indicator will disappear, confirming the time has been set.

NOTE: The clock has a 24-hour display.

Programmable Controller (POR783 only)

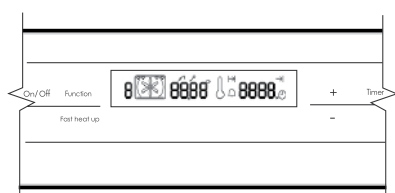

- After the appliance has been electrically connected, the set clock symbol ⊖ and timer arrow ► will flash on the clock display.
- To set the time of day, press – or +. 5 seconds after the last change the timer arrow ► will disappear, confirming the time has been set. Once the time has been entered, the clock advances minute by minute.

NOTE: The clock has a 24-hour display.

preparing your appliance for the first time

- Please remove all internal boxes and bags from the oven before operation.
- Please wipe out the oven interior prior to operation with warm soapy water and polish dry with a soft clean cloth. Do not close the oven door until the oven is completely dry.
- New appliances can have an odour during first operation. It is recommended to 'run in' your oven before you cook for the first time. Run the oven at 180°C for 2-4 hours and ensure that the room is well ventilated.
- DO NOT line the oven with foil, it will damage the enamel.
- If your appliance is fitted with a 2-hour "Auto Off" timer, make sure it is set to the 'Off' marker for manual operation. See image.

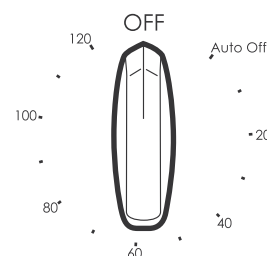

Setting the time (POR788 only)

After electrically connecting the appliance, you must set the time of day before you can operate your oven.

1. After the appliance has been electrically connected "12:00" will flash on the clock display, along with the scrolling message "Welcome to Electrolux".
2. To set the time of day in hours and minutes, press the – or + buttons underneath the "set clock" graphic.
3. 8 seconds after the last change the time will stop flashing, confirming the time has been set. Once the time has been entered, the clock advances minute by minute.

Note:

- The clock has a 12 hour display
- The display has 3 levels of brightness.
 - Brightest illumination: whenever the oven is in use.
 - Medium illumination: the oven is not in use.
 - Lowest illumination: the oven is not in use between the hours of 10pm and 6am.

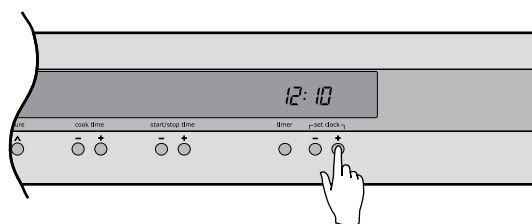

catalytic liners (on selected models)

Catalytic liners are coated with a specially formulated enamel coating. This porous coating enables the "self cleaning" process - see page 26 for more details. Catalytic liners must be installed first but you can omit them, if you wish, with no effect to cooking performance. Their sole purpose is to make oven cleaning easier.

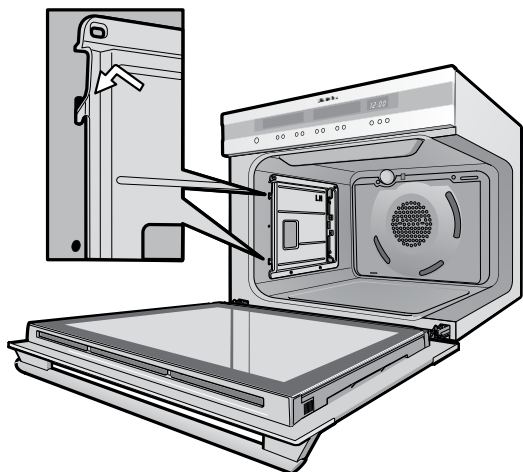

- The catalytic liners will attach to each side of your oven. There will be a left hand and right hand version. This is marked on the panel.
- Position the first liner as per the diagram. The black, shiny side of the liner should be facing the oven wall, the hooks pointing down and the word 'LH' positioned to the top rear portion of the oven. The right hand side will be a mirror image of this.
- Line the hooks up with the slots provided in the oven wall, push them in and then allow the liner to slide down to its final position.
- The access hole for the side racks should be visible when the liner is correctly positioned - see diagram.

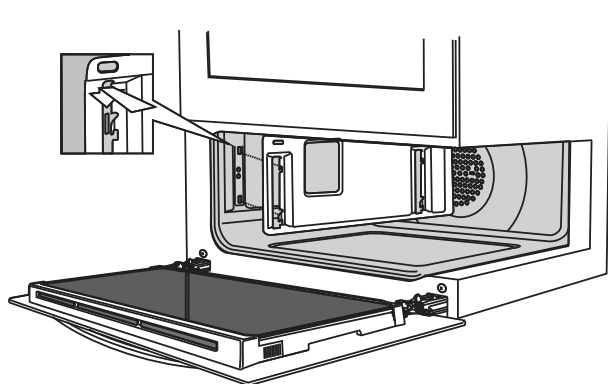

side racks

The side racks that come with your oven are all fitted the same way and can be attached to either side of your oven.

- Insert the largest peg into rear access hole provided. See diagram.
- Then locate the front peg into the front access hole and push in firmly.

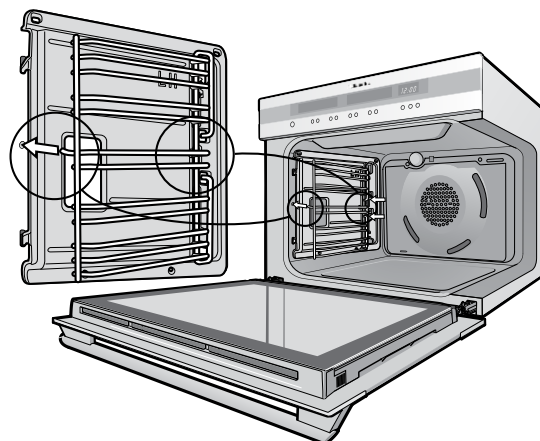

- When locating the left side racks into the small oven or grill ensure the pegs go into the top access holes.

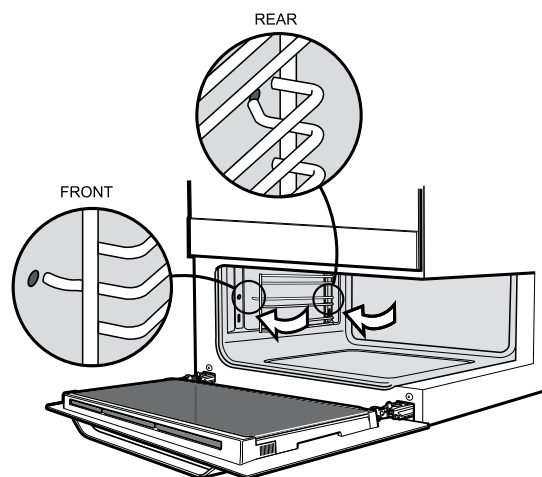

shelves and trays

The shelves are designed so that they have maximum travel but cannot be accidentally pulled right out. The trays are designed the same way and fit straight into the side racks.

- Locate the rear edge of the shelf/tray in between 2 guide rails of the side rack - see diagram. Ensure the same rail positions on both sides of the oven are being engaged.
- With the front edge raised, begin to slide the shelf into the oven.
- Once the detents have passed the front edge of the side rack, the shelf can be pushed completely in.
- When fully inserted the shelf/tray should not interfere with the closed oven door.
- To insert the grill tray in a separate grill underbench product, fully open the drawer and position the tray so that the slots on the outer edges fit over the tabs on the slides.
- Remove extra trays and dishes before roasting or baking.

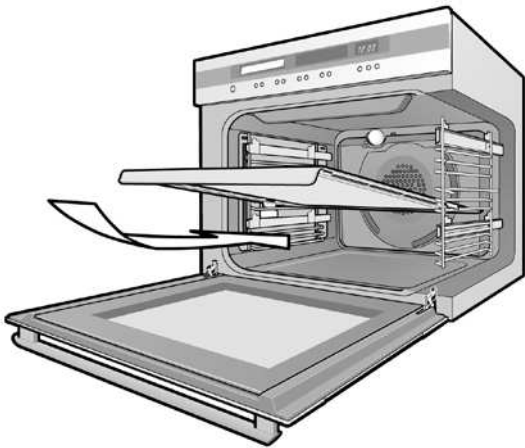

To fit a tray to telescopic slides:

1. Fully extend the slides on both sides.
2. Select the tray you wish to use and position the slots on one side on the respective tabs of the slide.
3. Drop the other side down so that the tray is fully seated on both slides.



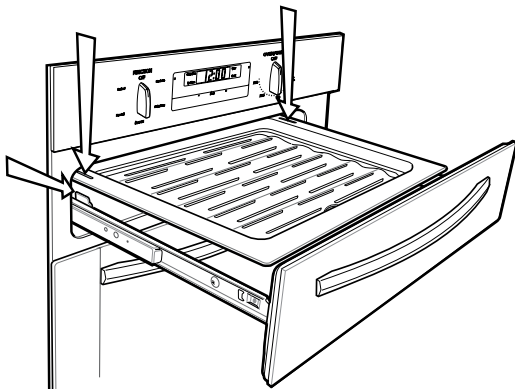



When fully inserted the shelf/tray should not interfere with the closed oven door.



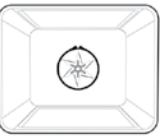

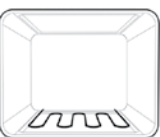
understanding your oven functions

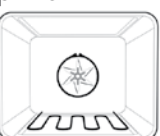
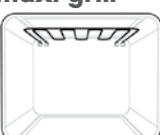
Your oven will have a selection of the following functions. Refer to "Description of your appliance" (page 4 and 5) to confirm what functions are available to you.



large oven

| function | description |
|---|---|
| rapid heat  | Heat comes from the element surrounding the fan as well as the smaller element above the food. This allows you to preheat your oven 30% quicker than on standard "bake". "Rapid heat" is ideal for cooking frozen pre-cooked foods such as savoury pastries, pizzas, mini meals (TV dinners), meat pies and fruit pies. Simply place the food in the oven straight from the freezer and heat - ideal for busy people. Cook in the upper half of the oven for best results. |
| fan bake  | Heat comes from the element surrounding the fan. This fan circulates the hot air around the oven cavity so that you can put your food in different places in the oven and still cook them at the same time. You can use the "fan bake" function for multi-shelf cooking, reheating cooked foods, pastries and complete oven meals. It will cook at a lower temperature and be faster than baking. Please note that some variation in browning is normal. |
| bake / pizza  | Heat comes from two elements, one above and one below the food. The bottom element is a clean heat element and is below the floor of the oven. Both elements are controlled by the thermostat and will turn on and off to maintain the set temperature. You can use the "bake" function for single trays of biscuits, scones, muffins, cakes, slices, casseroles, baked puddings, roasts and delicate egg dishes. |
| base heat  | Heat comes from the element below the food. The element is controlled by the thermostat and will turn on and off to maintain the set temperature. The "base heat" function can be used to add extra browning to the bases of pizzas, pies and pastries. Cook in the lower half of the oven when you are using only one shelf. For best results, use silver or shiny trays. |
| fan assist  | Heat comes from two elements, one above and one below the food. The fan circulates the hot air around the oven cavity so that you can put the food in different places in the oven and still cook them at the same time. You should only use a maximum of 2 shelves with "fan assist". Do not use the bottom shelf. If two shelves are used, food on the shelf in the higher position will cook first and should then be removed to allow the food on the lower shelf to finish cooking. |
| pizza  | "Pizza" is a combination of "base heat" and "fan bake" and offers you the combined benefits of both functions. Heat comes from the element surrounding the fan as well as the clean heat element below the oven floor. The "pizza" function is ideal for foods that require cooking and browning on the base. It is great for foods such as pizzas, quiches, meat pies and fruit pies. Simply place the food in the middle of the oven and set the desired temperature. |
| maxi grill  | "Maxi grill" directs radiant heat from 2 powerful upper elements onto the food. You can use the "maxi grill" function for tender cuts of meat, steak, chops, sausages, fish, cheese toasties and other quick cooking foods. Grill with the oven door closed. "Maxi grill" allows you to take full advantage of the large grill dish area and will cook faster than normal "grill". For best results it is recommended to preheat your grill for 3 minutes. This will help seal in the natural juices of steak, chops etc. for a better flavour. You can slide your grill dish into either of the 2 spaces within the upper pairs of support rails. |
| grill  | The "grill" directs radiant heat from the powerful upper element onto the food. You can use the "grill" function for tender cuts of meat, steak, chops, sausages, fish, cheese toasties and other quick cooking foods. Grill with the oven door closed. Preheat your grill for 3 minutes to get the best results. This will help seal in the natural juices of steak, chops etc. for a better flavour. You can slide your grill dish into either of the 2 spaces within the upper pairs of support rails. |
| fan grill  | "Fan grill" offers you the benefits of both "bake" and traditional "grill" functions. The grill element turns on and off to maintain the set temperature while the fan circulates the heated air. The oven door remains closed for fan grill. You can use "fan grill" for large cuts of meat in the large oven or smaller cuts in the mini oven (Duo only). This gives you a result that is similar to "roisserie" cooked meat. Put your food on a shelf in the second lowest shelf position. Put the grill dish on the lowest shelf position to catch any spills. When using "fan grill" it is not necessary to turn the food over during the cooking cycle. Set temperature to 180°C. |

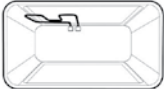
small oven/grill

| function | description |
|---|--|
| bake (duo oven only)  | Heat comes from the element below the food. The element is a clean heat element and is below the floor of the oven. The element is controlled by the thermostat and will turn on and off to maintain the set temperature. The "Bake" function can be used to add extra browning to the bases of pizzas, pies and pastries. |
| fan assist (duo oven only)  | Heat comes from the element below the food. The fan then circulates the hot air around the oven cavity allowing for very even cooking. |
| grill  | The "grill" directs radiant heat from the powerful upper element onto the food. You can use the "grill" function for tender cuts of meat, steak, chops, sausages, fish, cheese toasties and other quick cooking foods. Grill with the oven door open for separate grill wallovens and closed for Duo ovens. Preheat your grill for 3 minutes to get the best results. This will help seal in the natural juices of steak, chops etc. for a better flavour. The grill dish is to be positioned between the upper pair of support rails. |
| grill (split)  | The "split grill" works in the same way as a full width grill but with the added advantage of being able to optimise the energy usage for smaller servings. Grill with the oven door open. |

other functions

| function | description |
|---|--|
| fast heat up (POR783 only)  | "Fast heat" can be selected in the initial heat up phase of any cooking function. During "fast heat" the heat comes from the element surrounding the fan as well as the smaller element above the food. This allows you to preheat your oven 30% quicker than on standard "bake". See page 18 for more information. "Fast heat up" is not a cooking function. It is used to preheat the oven to the desired temperature quickly and efficiently. It is recommended to use this feature when preheating your appliance. The oven will automatically revert to the set cooking function once the preset temperature is reached. |
| defrost  | The "defrost" function uses low temperature air that is circulated by the fan. You can defrost (thaw) your food before you cook it. You can also use "defrost" to raise your yeast dough and to dry fruit, vegetables and herbs. |

cooling/venting fan

Your built-in appliance is fitted with a cooling fan. This prevents your kitchen cabinet from overheating and reduces the condensation inside the oven. It will operate whenever you are using your oven or grill and will blow warm air across the top of the oven door. In some appliances the cooling fan may continue to operate after the appliance is turned off. It will switch off by itself once oven is cool.

condensation

Excess condensation may fog the oven door. This may happen when you are cooking large quantities of food from a cold start. You can minimize condensation by:

- Keeping the amount of water used whilst cooking to a minimum.
- Making sure that the oven door is firmly closed.
- Baking custard in a baking dish that is slightly smaller than the water container.
- Cooking casseroles with the lid on.

NOTE: If you are using water in cooking, this will turn to steam and may condense outside your appliance. This is not a problem or fault with your oven.

operating your oven temperature selector

A thermostat controls the temperature in your appliance. The temperature can be selected within the specified range.

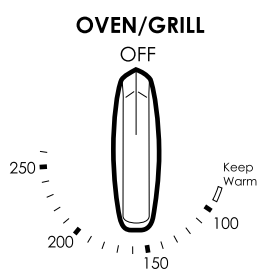

To set the temperature, turn the temperature selector in a clockwise direction to the desired setting. An indicator light above the temperature selector will come on. When the temperature is reached, the heating source switches itself off and the indicator light goes out. When the oven temperature falls below the desired setting, the heating source switches on and the indicator light comes on again. Once the food is cooked, turn the temperature selector back in an anti-clockwise direction. Do not force it right round in a clockwise direction as this will result in damage to the thermostat.

NOTE: For multifunction ovens the desired cooking function must be selected before the oven will operate. Once the desired function has been selected, use the temperature selector to set the required temperature.

pre-heating your appliance

For best results when baking you must preheat your oven for 30 minutes. Preheat the grill for 3 minutes to obtain best results. Pre-heating your appliance allows it to reach the required temperature quickly and efficiently.

With "rapid heat"

For electric multifunction appliances preheat your oven by selecting the "rapid heat" function.

This function allows your oven to reach the preset temperature quicker than any other cooking function.

1. Turn the function selector to "rapid heat".
2. Set the desired preheat temperature, by rotating your oven temperature selector.

When the indicator light above the temperature selector goes out, the oven has reached the desired temperature. Select the oven function you require for cooking or baking and place the food in the oven.

With "bake/pizza"

1. It is recommended you preheat your appliance when cooking or baking.
2. Set the desired preheat temperature, by rotating your oven temperature selector.

When the indicator light goes out the oven has reached the desired preset temperature, place your food in the oven, close the door and set the timer if you desire.

With "fan bake"

1. It is recommended to preheat your appliance when cooking or baking.
2. Set the desired preheat temperature, by rotating your oven temperature selector.

When the indicator light goes out the oven has reached the desired preset temperature, place your food into the oven, close the door and set the timer if you desire.

With "grill"

Preheat the grill for at least 3 minutes to obtain best results. This will help to seal the natural juices of steak, chops and other meats for a better flavour.

setting temperatures

The following table displays the temperature settings for recipes which do not show actual temperatures for non fan modes. For fan-forced modes the temperature should be reduced by 10°C.

| | oven | temp°C | temp°F |
|----------------------|-----------------|-----------|-----------|
| | Cool | 80 | 175 |
| low heat | Very slow | 100 - 110 | 210 - 230 |
| | Slow | 130 - 140 | 265 - 285 |
| moderate heat | Moderately slow | 150 - 160 | 300 - 320 |
| | Moderate | 170 - 180 | 340 - 355 |
| high heat | Moderately hot | 190 - 200 | 375 - 390 |
| | Hot | 200 - 210 | 390 - 410 |
| | Very hot | 220 - 230 | 430 - 450 |
| | Extremely hot | 240 - 250 | 465 - 480 |

Please refer to the cooking guide to choose the best oven setting for your recipes.

NOTES:

- *DO NOT line oven with foil, it will damage the enamel.*
- *DO NOT use the base of the oven for cooking – it will damage the enamel.*

warning

The ceramic cooktop is made from ceramic glass, a tough durable material that withstands heating and cooling without breaking. However, it must be remembered that as it is GLASS, it may break. Treat it accordingly!

The heating elements are concealed under the smooth glass surface which has a pattern to show the location of the elements. The glass will retain heat for a period of time after the appliance has been turned off. This is indicated by a "HOT SURFACE" warning light. It will remain on whenever the glass surface exceeds 60°C.

utensils

- Use pans with smooth, clean & dry bottoms to avoid scratching or burning residue into the glass.
- Ensure the pan bottom is the same size as the working element.
- We do not recommend ceramic glass pans because they do not conduct heat well. Stainless steel or enamelled saucepans are best.
- Do not use pans with copper or aluminium bottoms because they can leave traces which are difficult to remove from the glass.
- If buying new utensils select enamelled steel pans with 2-3mm thick bottoms or stainless steel pans with sandwich bottoms 4-6mm thick. The pan bottom should be flat, or preferably, slightly concave at room temperature so that it lies flat on the glass surface when hot.

cooking do's and don'ts

- Do use the stored heat in the hotplate by turning the control to "O" before the final few minutes of cooking.
- Do not place heat resistant mats, wire mats or aluminium foil under pots and pans.
- Do not allow pots and pans to boil dry, as damage to both pan and hotplate may result.
- Do not use round bottom woks, wok stands or similar utensils which could lead to overheating of the hotplates and possible damage to the cooking surface.
- Do not slide pans across the surface of the ceramic glass cooktop, it could result in scratching of the surface.
- Do not use the cooktop as extra bench space or as a cutting board.
- Do not allow children on or near the cooktop at any time.

cleaning your ceramic hotplate

1. Remove all spilt food and fat with a razor blade scraper (supplied with the unit) while the ceramic glass is still warm, but not hot. Wipe clean with dishwashing detergent on a damp cloth.
2. If aluminium foil, plastic items or high sugar content liquids/foods are allowed to melt on the ceramic glass, these should be removed immediately with a scraper before the surface has cooled down, otherwise pitting of the surface can occur.
NOTE: Items with high sugar content not only include jam and fruit but also vegetables such as peas, tomatoes and carrots.
3. When the ceramic glass is cool, apply a suitable cleaner (supplied with the unit).
4. It is important to follow the cleaner manufacturer's instructions. Remove any cleaning residue from the surface as staining of the cooktop may occur.
5. Do not use abrasive sponges or scourers, oven sprays or stain removers as they may scratch the cooktop.
6. Any pitting, staining, scratches or other surface deterioration is excluded from the warranty.
7. All stains/water marks can be removed by vigorous cleaning, using the supplied ceramic cleaner.

cooking hints

| | |
|-------------------------------------|---|
| bringing liquids to the boil | Use a high setting. |
| | Before the liquid begins to boil, turn to a lower setting. |
| | This will stop the liquid from boiling over. |
| using retained heat | Cooking areas will stay hot after they are turned off. |
| | Turn the cooking area off before cooking is finished and use retained heat to finish cooking. |
| turning to higher settings | If the pot does not have a lid, use a higher setting. |
| turning to lower settings | If the pot has a lid, then use a lower setting. |
| | Use a lower setting for foods which will easily burn eg milk, white sauce. |
| cooking too fast | If food is cooking too fast, take the pot off the cooktop. |
| | Turn the knob to a lower setting. |
| | Let the cooking area cool down and replace the pot. |

dealing with cooktop problems

| problem | possible cause | what to do |
|--|--|--|
| heating elements not working | Power not switched on | Check cooktop is plugged in and power is on |
| | Controls incorrectly set | Check correct knob turned for element |
| | Household fuse blown. If the fuse continues to blow, contact the Service Centre | Replace household fuse |
| benchtop becoming too hot and/or beginning to discolour | Wrong type of cooking pot | Make sure bases are not concave |
| | Pot may overhang cooktop | Place pot on centre of element so that it does not overhang |
| | Pot is too large | Use a smaller pot |
| food taking too long to cook | Pot base is not flat | Make sure pot base is flat or slightly convex |
| | Pot may be off centre | Centre pot over element making sure it does not overhang the cooktop |
| | Need to use larger element | Move pot to a larger element |
| | Using a round based wok | Use a flat based wok on electric cooktops |
| | Controls are incorrectly set | Check control is correct Check setting and increase setting |
| cannot simmer food | Control set too high | Turn control to lower setting |
| | Element too large | Use a smaller element |
| elements giving off smoke or odours when first used | Protective oils being removed in first cooking | Do not worry. This is normal |
| glass surface becomes milky white when pot removed | Base of pot is concave | Use a flat based pot |

**Models POR663, PORS663L/R, PPR776,
PGR657, PXR688**

2-hour “Auto Off” timer

The 2-hour timer features an automatic oven “cut off”. This means that a cooking period of up to 120 minutes can be set. When the timer has counted back to “Auto Off” a bell will sound and the oven will automatically switch off.

Once automatic baking is complete, return to manual operation by setting the timer to the ‘Off’ mark.

NOTE: It is not recommended to use this timer for short durations (e.g. boiling eggs).

Models POR667, PORS668L/R, POR668, PGR659, PXR698, PDR790, PDR794

touch control electronic clock

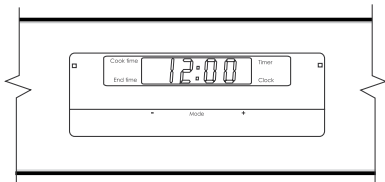

General features

Your touch control clock has the following features:

- **Timer** – allows you to set a countdown time that will beep when the set time has elapsed.
- **Cooking duration** – You can set a cooking duration. A timer will count down the preset cooking time, beep when the time has elapsed and turn the oven off.
- **End cooking time** – you can set a cooking finish time. A timer will count down the preset cooking time, beep when the finish time has been reached and turn the oven off.
- **Delayed start cooking time** – You can combine the cooking time and stop cooking time to switch the oven on and off at a specific time during the day.

NOTE: Your touch control clock only operates with your main oven.

Setting the time of day

You must set the time of day before you can operate your appliance. When power is supplied to your oven "12.00" will be displayed and the "clock" indicator **|** will flash.

1. To set the time of day in hours and minutes, press – or +. 5 seconds after the last change, the "clock" indicator **|** will disappear, confirming the time has been set.

NOTE: The clock has a 24-hour display.

Change the time of day (daylight saving)

1. Press "mode" until the "clock" indicator **|** begins flashing.
2. Press – or + to change the time. 5 seconds after the last change, the "clock" indicator **|** will disappear, confirming the time has been set.

Setting the timer

1. Press "mode" until the "timer" indicator **|** begins flashing.
2. Set the countdown time you want by using – and +. 5 seconds after the last change the "timer" indicator **|** will stop flashing, confirming the timer has been set.
3. To stop the beeper, press –, + or "mode".

Setting the cooking duration

1. Check the clock displays the correct time of day.
2. Select the desired oven function and temperature. The oven indicator light will glow and the heating source will come on.
3. Press "mode" until the "cook time" indicator **|** begins flashing.

4. Set the cooking duration you want by using – or +. 5 seconds after the last change, the "cook time" indicator **|** will stop flashing, and the time of day will be displayed.

NOTE: Do not forget to add preheating time if necessary.

Setting the cooking end time

1. Check the clock displays the correct time of day.
2. Select the desired oven function and temperature. The oven indicator light will glow and the heating source will come on.
3. Press "mode" until the "end time" indicator **|** begins flashing.
4. Enter the time of day you want to finish cooking by pressing – or +. 5 seconds after the last change, the "end time" indicator **|** will stop flashing and the current time of day will be displayed.

Setting the delayed start cooking time

1. Program the "cook time" and "end time" as described in the relevant sections. Once both the "cook time" and "end time" have been set, the "cook time" and "end time" indicators will stop flashing and the current time of day will be displayed.

To check or cancel settings

1. To check your settings, press "mode" until the setting you want is displayed. A red light will flash next to the mode (cook time, end time etc) that is currently on display.
2. To cancel "delayed start" press "mode" until a light flashes next to "end time". Press and hold "–" until the clock no longer reverses ("0:00" and you will hear a beep). If you have left the temperature and function knobs at a setting the oven will start once the "end time" light stops flashing.
3. To cancel "auto shut off" press "mode" until a light flashes next to "cook time". Press and hold "–" until the clock no longer reverses ("0:00" and you will hear a beep). This automatically cancels "delayed start". If you have left the temperature and function knobs at a setting, the oven will start once the "cook time" light stops flashing. Because you have cancelled "auto off" the oven will continue to heat until you manually turn it off.

On completion of cooking

The oven will turn off, the timer will beep and the "end time" and/or "cook time" indicators will flash.

1. Turn the function and temperature controls to the off position.
2. Press "+" or "–" or "mode" to stop the timer from beeping.

Switching the clock display ON and OFF

1. Press together "+" and "–" for 2 seconds to switch 'off' the display.
2. Press together "+" and "–" for 2 seconds to switch the clock display 'on' again.

NOTE: If a timer mode is set, then it is not possible to switch the display off.

touch control

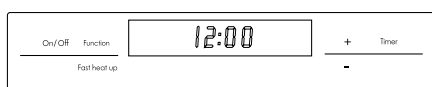

Setting the time of day

After the appliance has been electrically connected the "set clock" symbol ⌚ and "timer arrow" ► will flash on the clock display.

1. To set the time of day in hours and minutes press the – or +. 5 seconds after the last change the "timer arrow" ► will disappear, confirming the time has been set.

NOTE: The clock has a 24-hour display.

Change the time of day (daylight saving)

1. Switch off the appliance by pressing "On / Off".
2. Press "Timer" as many times as necessary until the "set clock" symbol ⌚ and "timer arrow" ► flash on the clock display.
3. Press "+" or "-" to change the time. 5 seconds after the last change the "set clock" symbol ⌚ and "timer arrow" ► will disappear, confirming the time has been set.

Setting the oven function

1. Switch on the appliance by pressing the "On / Off". The oven lights will light.
2. Press the "Function" as many times as necessary until the desired function appears. The suggested cooking temperature appears in the display and the degrees symbol "°" flashes. If the suggested temperature is not changed within approximately 5 seconds the degrees symbol "°" stops flashing and the oven begins to heat. The suggested temperature display is replaced with the oven centre temperature and a thermometer icon. The thermometer icon rises slowly, indicating the degree to which the oven is currently being heated.

Changing the oven temperature

1. Press the – or +, to decrease or increase the temperature.
NOTE: The temperature can only be adjusted when the degrees symbol "°" is flashing. The temperature setting changes in increments of 5°C. To change the temperature after the degrees symbol "°" stops flashing, press the "Function" and then press the – or + to change the temperature.

Setting the cooking time

1. Select the desired oven function and cooking temperature.
2. Press the "Timer" as often as necessary, until the "cook time" ⏱ symbol appears.
3. Set the desired cooking time by using the – or +, whilst the "timer arrow" ► is flashing. After 5 seconds from the last time adjustment the "timer arrow" ► will disappear and your appliance is now programmed.
4. When the set time has elapsed, a signal will sound. To stop the signal, press "+" or "-".

Setting the stop time

1. Select the desired oven function and cooking temperature.
2. Press the "Timer" as often as necessary, until the "end time" symbol ⏸ appears flashing.
3. Set the desired switch-off time using the – or + whilst the "timer arrow" ► is flashing. After 5 seconds from the last time adjustment the "timer arrow" ► will disappear and your appliance is now programmed.
4. When the set time has elapsed, a signal will sound. To stop the signal, press "+" or "-".

Setting the delayed start cooking time

The "cook time" and "stop time" functions can be combined to switch the oven on and off at a specific time during the day.

1. Select the desired oven function and cooking temperature.
2. Press "Timer" as often as necessary, until the "cook time" symbol ⏱ appears.
3. Set the desired cooking time by using – or +, whilst the "timer arrow" ► is flashing.
4. Press "Timer" as often as necessary, until the "end time" symbol ⏸ appears flashing.
5. Set the desired switch-off time using the – or + whilst the "timer arrow" is flashing. The "cook time" ⏱ and "end time" ⏸ arrows are lit to confirm that the oven has been programmed.

On completion of cooking

When the set time has elapsed, a signal will sound for 1 minute, the oven will switch off and the remaining time indication "0.00" will appear on the display.

1. To stop the signal, press "+" or "-".

Setting the minute minder

For setting a countdown period. When the period of time has elapsed, an audible signal is sounded.

NOTE: This feature has no effect on the oven operation.

1. Press "Timer" as often as necessary, until the "minute minder" symbol ⏰ appears flashing. Set the desired length of time using – or + whilst the "timer arrow" ► is flashing. After 5 seconds from the last time adjustment the "timer arrow" ► will disappear and the minute minder has been set. Once the set time has elapsed, a signal will sound for 1 minute. The time indication "0.00" and a flashing "minute minder" symbol ⏰ will appear on the display.
2. To stop the signal, press "+" or "-".

Using FHU (Fast Heat Up) mode

To quickly and efficiently preheat your oven, it is recommended to select the "Fast Heat" cooking feature.

1. Ensure the appliance is on by pressing the "On / Off".
The oven lights will light.
2. Select the desired oven function by pressing "Function".
3. Set the cooking temperature by pressing the – or + to decrease or increase the temperature.

NOTE: The temperature can only be adjusted when the degrees symbol "°" is flashing. The temperature setting changes in increments of 5 °C.

4. Press the "Fast Heat". The letters "FHU" will appear on the temperature display.
5. When the set temperature is reached the buzzer will sound and the set temperature will be displayed.

NOTE: "FHU" cannot be selected if the oven centre temperature is above the preset temperature.

Activating the child-proof lock

When the child lock is engaged, the oven cannot be switched on.

1. Switch off the appliance using the "On / Off".
2. Press "Function" and – at the same time, hold until the word "SAFE" is displayed.

The child-proof lock is now engaged.

NOTE: When the child-proof lock function is active the time of day and minute minder can only be set.

Releasing the child-proof lock

1. Press "Function" and – at the same time, hold until the word "SAFE" is cleared from the display. The child-proof lock is now released and the oven is ready to use.

Beep on touch

The beep sound can be activated anytime when a symbol is pressed.

1. Ensure the oven is off by pressing "On / Off".
2. Press "Function" and + simultaneously for 2 seconds, a single beep will sound to confirm the operation. Repeat the above procedure to reset the beep on touch mode. As default, the beep on touch mode is off.

Demo mode

This mode is intended to be used in retail shops to demonstrate the oven functionality without any power consumption except the oven lamps.

1. To activate this feature the appliance should be in stand-by mode. (No function selected).
2. Press and hold "Fast Heat" and + for 2 seconds, the appliance will beep once. When the appliance is initially turned on the letter "d" will appear in the left hand corner of the display to confirm that the appliance is in demo mode. All functions can be selected, but the thermometer icon will not flash. Repeat the above procedure to deactivate the demo mode.

Safety cut-out feature

The oven automatically switches itself off if the temperature is not adjusted or the appliance is left operating after a period of time. The oven switches itself off after:

- 20 hours when set between 30°C and 120°C
- 8.5 hours when set between 120°C and 200°C
- 5.5 hours when set between 200°C and 250°C

Your oven is equipped with a programmable controller that can be used to turn on and off the oven automatically. The cook time is used to automatically turn the oven off after a set amount of time.

Setting the cook time

1. Select the desired oven function and cooking temperature.
2. Press the "cook time +" button as often as necessary, until the desired cook time has been set.
3. After 8 seconds from the last time adjustment your oven will be programmed and will start cooking.

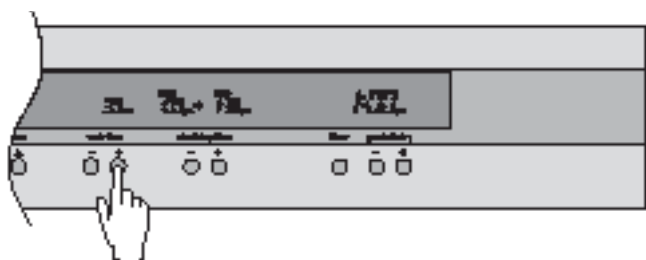

Note:

- During cooking, you can adjust the cook time with the Cook time - or + buttons for better cooking performance.

Setting the start/stop time

The start/stop time can be used to switch the oven On and Off at a specific time during the day.

1. Check the clock displays the correct time of day.
2. Select the desired oven function and cooking temperature.
3. Set the required cook time.
4. Press the "start/stop" time + button to move the start and stop time forward.
5. After 8 seconds from the last time adjustment the DELAY SET icon will light and your oven is now programmed. The oven will start cooking when the time of day reaches the set start time.

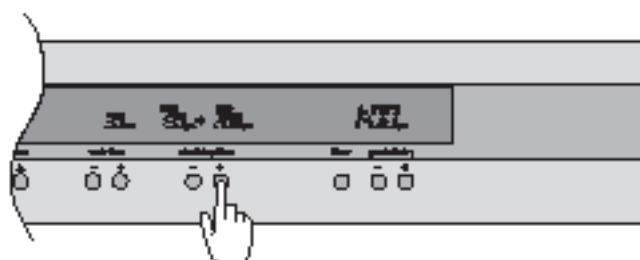

Note:

- 30 seconds after a programmed cooking function has started, it is no longer possible to delay the start time.
- In order to delay a cooking function that has already started, the oven needs to be switched Off using the ON/OFF button, then switched on again and re-programmed.

On completion of cooking

When the cook time has elapsed, an audible signal will sound for 10 seconds, the oven will switch off and

COOKING FINISHED will be displayed on the left hand side of the display. On the right hand side of the display, the remaining time indication "0 min" will appear together with the cooking start and stop time.

- To stop the audible signal, press any of the buttons on the control panel.
- If you wish to cook a bit longer, press the "cook time +" button for each additional minute you require. The oven automatically reverts to the function and temperature previously programmed. This feature is available for 5 minutes after cooking has finished. After that, the oven automatically switches off.

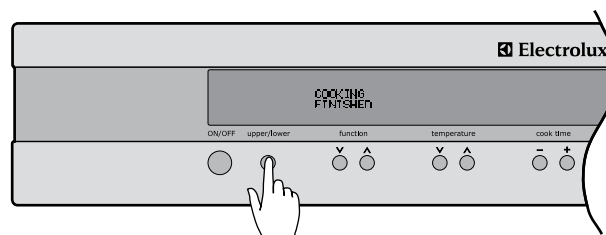

environmental tips

You can use the residual heat in the oven for keeping food warm.

tips & information

Even though the heating element turns off the oven will still retain substantial heat. This will continue to cook the food until it is removed or the oven cools down. If you do not plan on being present when the oven turns off, you should take this extra heating time into account.

Setting the timer

The timer can be used independently of the oven for setting a countdown period. When the period of time has elapsed, an audible signal sounds.

1. Press the timer button.
2. Set the desired length of time using the - or + buttons whilst the timer bell is flashing. After 8 seconds from the last adjustment the timer bell will stop flashing and the timer will start to count down.
3. When the set time has elapsed, an audible signal will sound for 10 seconds. The time indication "0 min" and the timer bell will flash on the display.
4. To stop the signal, press any of the 3 buttons below the Clock/Timer display.

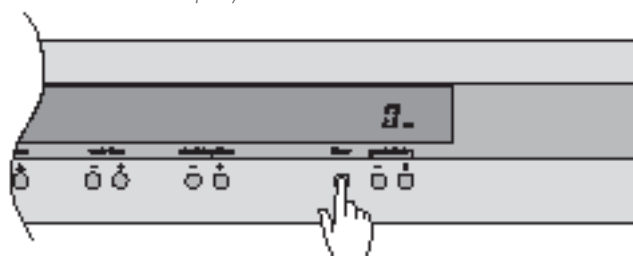

Note:

- This feature has no effect on the oven operation.

Adjusting the clock

The time of day is independent of the oven and can be adjusted at any point.

1. To set the time of day in hours and minutes press and hold the **-** and **+** buttons simultaneously for 1 second until the dots on the clock display start flashing.
2. Adjust the time of day using the **-** and **+** buttons.
3. After 8 seconds from the last adjustment, the dots will stop flashing, confirming the time has been set. You can also confirm your changes by pressing the timer button.

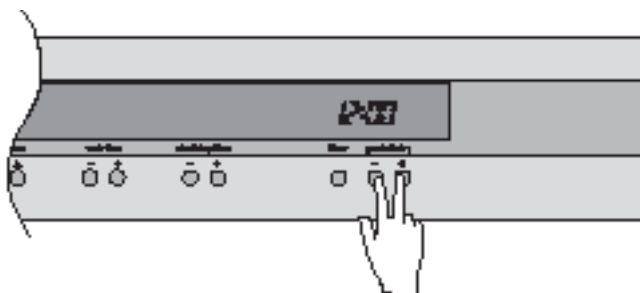

Demo Mode

This mode is intended to be used in retail shops to demonstrate the oven functionality without any power consumption except to the oven lamps.

1. Ensure the oven is off by pressing the ON/OFF button.
2. Press and hold the ON/OFF button until the display turns ON then OFF. Immediately after press the cooktime buttons simultaneously, hold until the words 'Demo mode' are displayed, a single beep will sound to confirm the operation.

Releasing Demo Mode

1. Ensure the oven is off by pressing the ON/OFF button.
2. Press and hold the ON/OFF button until the display turns ON then OFF. Immediately after press the cooktime buttons simultaneously, hold until the words 'Normal mode' are displayed, a single beep will sound to confirm the operation.

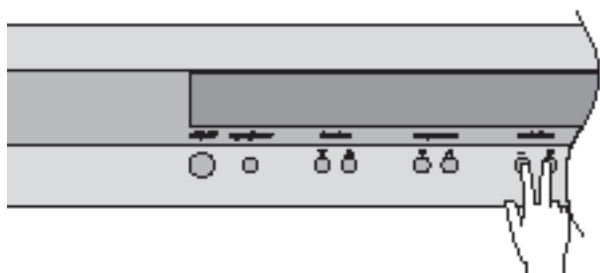

Activating the child lock

When the child lock is engaged, the oven cannot be switched on.

1. Switch off the appliance using the "ON/OFF" button.
2. Press the function buttons simultaneously, hold until the words LOCKED are displayed, a single beep will sound to confirm the operation. The child lock is now engaged.

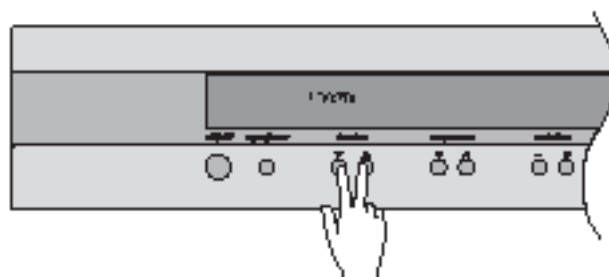

Note:

- When the child lock function is active, only the clock and timer can be set.

Releasing the child lock

Press the function buttons at the same time, hold until the word LOCKED is cleared from the display. The child lock is now released and the oven is ready to use.

Beep on touch

The beep sound can be activated anytime a button is pressed.

1. Ensure the oven is off by pressing the ON/OFF button.
2. Press the temperature buttons simultaneously for one second, a single beep will sound to confirm operation. Repeat the above procedure to reset the beep mode to touch mode. As default the beep on touch mode is off.

Maximum operation times for safety

The oven automatically switches itself off if the temperature is not adjusted or the appliance is left operating for:

- 12.5 hours when set between 30°C and 120°C
- 8.5 hours when set between 120°C and 200°C
- 5.5 hours when set between 200°C and 250°C

cooking hints

- Select the correct shelf location for food being cooked.
- Make sure dishes will fit into the oven before you switch it on.
- Keep edges of baking dishes at least 40mm from the side of the oven. This allows free circulation of heat and ensures even cooking.
- Do not open the oven door more than necessary.
- Do not place foods with a lot of liquid into the oven with other foods. This will cause food to steam and not brown.
- After the oven is turned off it retains the heat for some time. Use this heat to finish custards or to dry bread.
- Do not use a lot of cooking oil when roasting. This will prevent splattering oil on the sides of the oven and the oven door. Polyunsaturated fats can leave residue which is very difficult to remove.
- When cooking things which require a high heat from below (e.g. tarts), place the cooking dish on a scone tray in the desired shelf position.
- For sponges and cakes use aluminium, bright finished or non-stick utensils.
- Remove unnecessary trays or dishes when roasting or baking.

oven shelf location

Your oven has seven for shelves. These are numbered from 1 (the lowest shelf position) to 7 (the highest shelf position). See diagram.

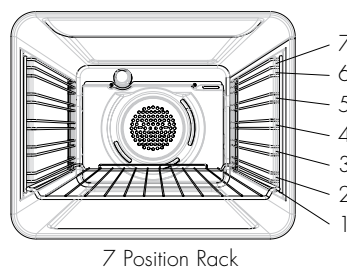

To give maximum space above and below the shelves, load them in this way:

- When cooking with 1 shelf, use position 3 or 4.
- When cooking with 2 shelves, use position 3 and 5. Refer to cooking guide.

Use the oven efficiently, by cooking many trays of food at the same time. For example:

- Cook 2 trays of scones, small cakes or sausage rolls.
- Cook a roast dinner at the same time as you cook chips or vegetables.

choosing the best oven settings

The following table is intended as a guide and experience may show some variation in cooking times necessary to meet individual requirements. It may be necessary to change some cooking times and temperatures from previous oven. For best baking results preheat oven for 30 minutes.

Modes without Oven Fan

| food | | temperature °C | oven shelf position* | time in minutes |
|----------------------------|---------------------|----------------|----------------------|-----------------|
| scones | Plain or fruit | 220 | 2 | 10 -15 |
| biscuits | Rolled | 170 | 2 | 10 - 15 |
| | Spooned | 190 | 2 | 12 - 15 |
| | Shortbread biscuits | 160 | 1 or 2 | 30 - 35 |
| meringues | Hard - individual | 110 | 2 | 90 |
| | Soft - individual | 180 | 2 | 15 - 20 |
| | Pavlova - 6 egg | 110 | 1 | 75 |
| cakes | Patty cakes | 190 | 3 | 15 - 20 |
| | Sponge - 4 egg | 180 | 2 | 20 - 30 |
| | Shallow butter cake | 180 | 2 | 30 - 40 |
| | Rich fruit cake | 140 | 2 | 180 |
| pastry - shortcrust | Cornish pasties | 200 | 2 | 40 - 45 |
| | Custard tart | 200 / 180 | 1 | 10 / 20 - 30 |
| pastry - choux | Cream puffs | 210 | 2 | 25 - 30 |
| yeast goods | Bread | 210 | 1 | 25 - 30 |

*Counting from the bottom shelf up.

Modes with Oven Fan

| food | | temperature °C | oven shelf position* | time in minutes |
|----------------------------|---------------------|----------------|----------------------|-----------------|
| scones | Plain or fruit | 210 | any | 10 - 15 |
| biscuits | Rolled | 150 | any | 10 - 15 |
| | Spooned | 180 | any | 12 - 15 |
| | Shortbread biscuits | 150 | any | 30 - 35 |
| meringues | Hard - individual | 100 | any | 90 |
| | Soft - individual | 165 | any | 15 - 20 |
| | Pavlova - 6 egg | 100 | any | 75 |
| cakes | Patty cakes | 180 | any | 15 - 20 |
| | Sponge - 4 egg | 170 | any | 20 - 30 |
| | Shallow butter cake | 170 | any | 30 - 40 |
| | Rich fruit cake | 130 | any | 180 |
| pastry - shortcrust | Cornish pasties | 180 | any | 40 - 45 |
| | Custard tart | 190 / 170 | any | 20 - 30 |
| pastry - choux | Cream puffs | 200 | any | 25 - 30 |
| yeast goods | Bread | 200 | any | 25 - 30 |

*Counting from the bottom shelf up.

Roasting Meat

- Place the meat in the oven and set the temperature between 180°C and 200°C. (It is recommended to wrap your meats in an oven roasting bag or foil to prevent fats and oils from splattering, making it easier to clean your oven.)
- Use the grill / oven dish and smokeless grill insert. Place the meat on the insert.
- Do not pierce the meat, as this will allow juices to escape.
- When the meat is cooked, take the roast out of the oven, wrap in aluminum foil and leave to stand for about 10 minutes. This will help retain the juices when the meat is carved. The table shows temperatures and cooking times for different kinds of meat. These may vary depending on the thickness or bone content of the meat.

| meat | recommended temperature | | minutes per kg |
|-------------|-------------------------|-----------|----------------|
| beef | 200°C | Rare | 35 - 40 |
| | | Medium | 45 - 50 |
| | | Well done | 55 - 60 |
| lamb | 200°C | Medium | 40 |
| | | Well done | 60 |
| veal | 180°C | Well done | 60 |
| pork | 200°C | Well done | 60 |

Roasting poultry and fish

- Place the poultry or fish in an oven set at a moderate temperature of 180°C.
- Place a layer of foil over the fish for about three quarters of the cooking time.

The table shows temperatures and cooking times for different kinds of fish and poultry. These may vary depending on the thickness or bone content of the meat.

| poultry & fish | recommended temperature | minutes per kg |
|----------------|-------------------------|-----------------|
| chicken | 180°C | 45 - 50 |
| duck | 180 - 200°C | 60 - 70 |
| turkey | 180°C | 40 - 45 (<10kg) |
| | | 35 - 40 (>10kg) |
| fish | 180°C | 20 |

grilling hints



warning

Always clean the grill / oven dish after every use. Excessive fat build up may cause a fire.

Depending on your model of appliance you will grill:

- With the door open, if you are grilling in the separate grill wall-oven compartment.
- With the drawer approximately two finger widths ajar, if you are grilling in the separate grill underbench compartment.
- With the door open or closed, if you are grilling in the oven compartment.

As a method of cooking, grilling can be used to:

- Enhance the flavours of vegetables, fish, poultry and meat.
- Seal the surface of the food and retain the natural juices.

This table shows how to grill different types of meat:

| food | grilling method |
|-----------------|--|
| beef | You can use tenderloin, rump and sirloin. Brush with oil or melted butter, especially if the meat is very lean. |
| lamb | You can use the loin chops, shortloin chops, chump chops and forequarter chops. Remove skin or cut at intervals to avoid curling. Brush with oil or melted butter. |
| sausages | Prick sausages to stop skin from bursting. |
| poultry | Divide into serving pieces. Brush with oil. |
| fish | Brush with oil or melted butter and lemon juice. |
| bacon | Remove rind. Grill flat and make into rolls. |

Guide to better grilling

No definite times can be given for grilling because this depends on your own tastes and the size of the food. These times should only be used as a guide and remember to turn the food over half way through the cooking process.

| food | time in minutes |
|--------------|-----------------|
| steak | 15 - 20 minutes |
| chops | 20 - 30 minutes |
| fish | 8 - 10 minutes |
| bacon | 4 - 5 minutes |

For better grilling results, follow these easy instructions:

1. Remove oven / grill dish and smokeless grill insert and preheat grill for about 5 minutes.
2. Choose only prime cuts of meat or fish. If the cut is less than 5mm thick it will dry out. If the cut is more than 40mm thick, the outside may burn whilst the inside remains raw.
3. Do not place aluminium foil under the food as this prevents fats and oils from draining away, which could result in a fire.
4. Baste the food during cooking with butter, olive oil or marinade. Grilled food is better if marinated before cooking.
5. Use tongs to turn food as a fork pierces the surface and will let juices escape.

fan grill (multifunction models only)

If your appliance has fan grill as a function, this will assist the grilling process by circulating the heat evenly around the food. The recommended temperature setting is 180°C for all fan grilling functions.

1. Use the smokeless grill insert and oven dish for all fan grilling.
2. Position the dish in the lower half of the oven, for best results.
3. Wipe off any oil or fat which spatters while the oven is still warm.

There is no need to turn the meat as both sides are cooked at the same time which means that the food is succulent.

| problem | causes | what to do |
|--|---|--|
| uneven cooking | Incorrect shelf position | Select shelf that puts food in centre of oven |
| | Oven tray too large | Try other trays or dishes |
| | Trays not in centre | Put trays in centre |
| | Air flow in oven uneven | Rotate food during cooking |
| | Grill tray affecting thermostat | Remove grill tray from oven on bake modes |
| baked products too brown on top | Oven not preheated | Preheat the oven |
| | Baking tins too large for recipe | Use correct size tins |
| | Baking tins not evenly spaced | Stagger baking tins at least 3cm between tins and the oven walls |
| | Products not evenly sized or spaced on trays | Make into same size and shape and spread evenly over trays |
| baked products too brown on bottom | Baking tins too large | Use correct size tins |
| | Baking tins are dark metal or glass | Change to shiny, light tins or lower the temperature by 10°C |
| | Food too low in oven | Cook one shelf higher |
| | Oven door opened too frequently during baking | Don't open the oven door until at least half the cooking time has passed |
| | Baking temperature too high | Lower the temperature |
| | Grill tray affecting thermostat | Remove grill tray from oven on bake modes |
| cakes have a cracked thick crust | Baking temperature too high | Lower the temperature |
| | Food too low in oven | Cook one shelf higher |
| | Cake batter over mixed | Mix just long enough to combine the ingredients |
| | Baking tin too deep | Check size of tin and use recommended size |
| | Baking tins dark | Change to shiny light tins |
| baked products are pale, flat and undercooked | Baking temperature too low | Raise the temperature |
| | Food too low in oven | Cook one shelf higher |
| | Baking time too short | Increase cooking time |
| | Incorrect baking tin size | Use correct size tin |
| cakes fallen in centre | Baking temperature too low | Raise the temperature |
| | Baking time too short | Increase cooking time |
| | Proportions of ingredients incorrect for recipe | Check recipe |
| | Opening door too early during baking | Do not open door until the last quarter of cooking time |
| roast meat and potatoes not brown in fan oven | Poor hot air circulation | Elevate food onto a rack to allow air circulation |
| | Grill tray affecting thermostat | Remove grill tray from oven on bake modes |
| juices running out of meat | | Do not pierce meat with fork, turn with tongs |
| grilled meats overcooked on outside & raw in the centre | | Grill at lower insert position |
| grilled chops & steaks curling | | Cut into fat every 2cm (¾") |

warning

- Always make sure that the oven is electrically isolated before cleaning. This can be done via the functional switch located nearby. Do not use steam cleaners.
- Do not line the bottom of the oven or grill with foil or cookware.

enamel

- Rub persistent stains vigorously with a nylon scourer or creamed powder cleansers.
NOTE: You can also use household oven enamel cleaners - follow the manufacturer's instructions carefully.
- Do not use harsh abrasive cleaners, powder cleaners, steel wool or wax polishes.

stainless steel

All grades of stainless steel can stain, discolour or become greasy. You must clean these areas regularly by following the procedures below, if you want your appliance to look its best, perform well and have a long life.

warning

Care must be taken when wiping exposed stainless steel edges....they can be sharp!

Your stainless steel appliance is manufactured from a mark resistant stainless steel. This special stainless steel resists marks such as finger prints and water spots. To keep your stainless steel appliance looking at its best, you should clean it regularly. Wash with warm soapy water and rinse with clean water. Wipe with clean water and a soft clean cloth to remove soap residue.

NOTE: Make sure you follow the polish or brushing lines in the steel.

caution

DO NOT use stainless steel cleaners, abrasive pads or other cleaners as they are likely to scratch the surface. Damage due to poor cleaning technique is not covered by your warranty.

glass

- Glass surfaces on doors and control panels are best cleaned immediately after soiling.
- A damp cloth may help remove baked on food deposits.
- Oven cleaners can be used to remove stubborn marks and stains.

DO NOT use harsh abrasive cleaners or sharp metal scrapers to clean the oven door since they can scratch the surface, which may result in shattering of the glass

oven

- Always keep your appliance clean. Ensure that fats and oils do not accumulate around elements, burners or fans.
- Always keep the oven dish, baking trays, grill dish and grill dish inserts clean, as any fat deposits may catch fire.
- Always wrap your meats in foil or an oven roasting bag to minimise cleaning. Any polyunsaturated fats can leave a varnish-like residue which is very difficult to remove.

grill

- Always keep the grill dish and grill dish insert clean, as any fat deposits may catch fire.

cleaning your oven accessories

Removing the trays and shelves from your appliance

- Slide the dish and shelves towards you until they reach the front stop.
- Tilt them up at the front to clear the side supports, taking care not to spill the contents.
- Lift them clear.
- Wash the dish and insert the shelves in hot soapy water.
- Reverse the above steps to put the grill dish and shelves back again.
- Ensure that they are placed between the 2 support wires. See page 8 for more details.

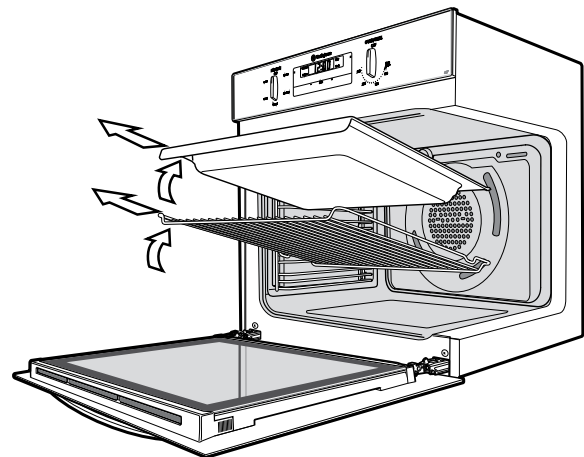

Removing the side racks (shelf supports)

- Grasp the shelf supports at the front.
- Pull them firmly inwards.
- To install the shelf supports, see page 7.

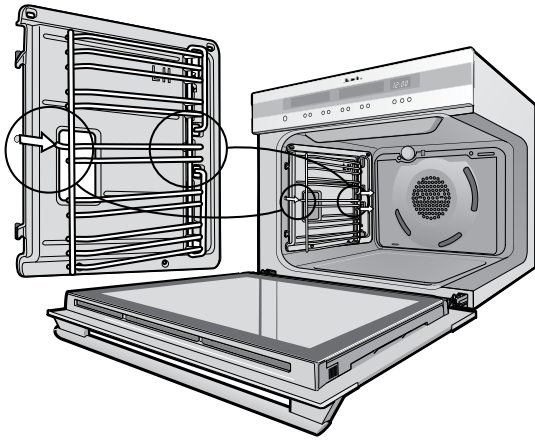

Removing and replacing the oven light and side light (where fitted)

- Turn oven light glass anticlockwise to remove it for globe replacement.
- A special high temperature resistant globe should be used. This can be purchased from the Customer Care Centre.
- To remove side light, place a spoon under the light glass and lever off. Replace globe and snap glass cover back into position.

warning

Make sure the appliance is turned off before you remove or replace parts, to avoid the possibility of electric shock.

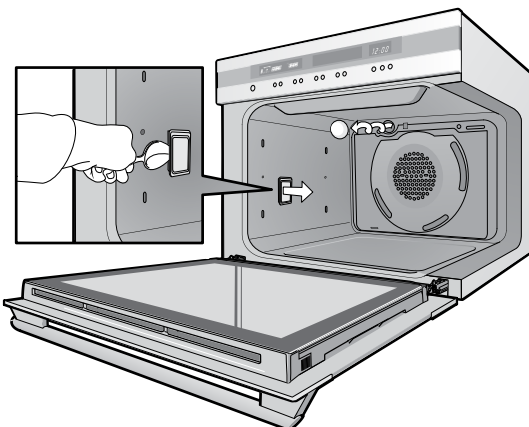

releasing the grill element

We have designed the upper element with a hanger clip to help you reach your oven roof for cleaning.

Retaining wire models

- Lift element up carefully.
- Pull hanger clip to the left or right to unhook it. The element will drop down freely.

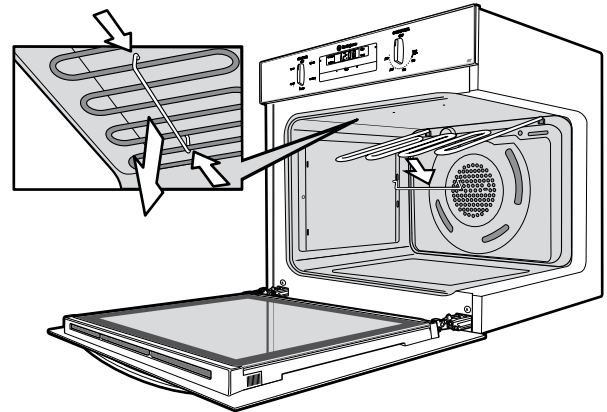

Rotating latch models

- Rotate latch 180°. The element will drop down freely.

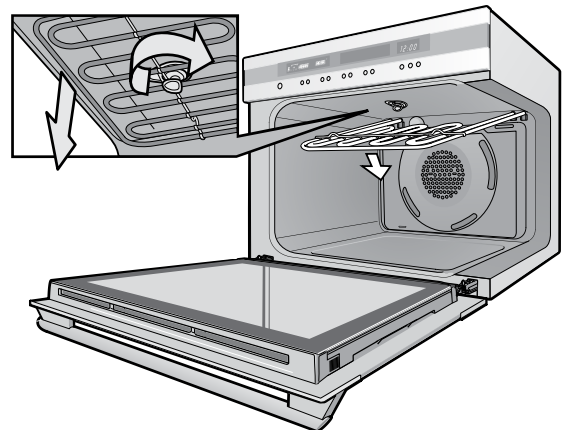

catalytic liners

Some models come with Catalytic liners. These models contain:

- 2 Catalytic side liners (to be fitted by you)
- 1 Catalytic fan cover (already fitted)

NOTE: If your oven does not have catalytic liners and you wish to purchase them, they are available from the Customer Care Centre.

operation

The catalytic liners are coated with a specially formulated enamel coating, over a base of regular enamel. This enamel coating has a rough surface which is also porous. During normal cooking, fats and other food spatter is partially absorbed into the surface and then oxidised away. This oxidisation of the fat works best if the oven is set at high temperatures. If you do a lot of lower temperature baking, say around the normal 180°C, then the cleaning process may not be complete. Every now and then you should turn the oven on to 260°C for around one hour to completely remove the soil.

cleaning

Should the panels become heavily soiled, they will need to be taken out of the oven and cleaned by hand. They should be soaked in warm, soapy water for at least 2 hours and then wiped clean with a soft cloth.

NOTE: Solid cleaning powders, creamy cleansers, caustic oven cleaners, steel wool or other scourers will ruin the catalytic surface and must NEVER BE USED.

Removing the catalytic liners

- Remove Side Racks (see page 24).
- Lift the liner up to disengage the hooks.
- The liners should now be free to be pulled in towards the centre of the oven.
- Refer to page 7 for re-installing your side liners.

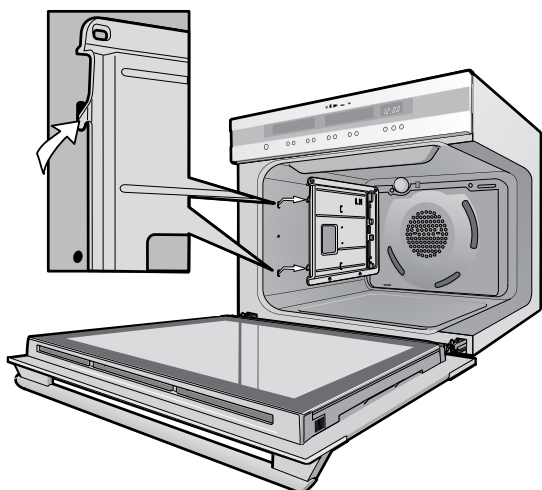

Removing and replacing the catalytic fan baffle (where fitted)

- Remove the 2 retaining screws on the top edge of the fan baffle.
- Pull the top edge towards you and then disengage to bottom tabs from the oven back.

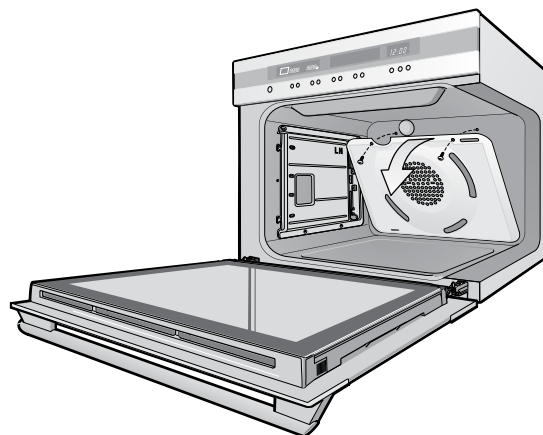

important

NOTE: The fan baffle must be replaced after cleaning.

- Insert the two tabs at the bottom of the fan baffle into their corresponding slots in the oven back.
- Push the top home and insert screws firmly into appropriate holes.
- The fan baffle must not be loose.

! warning

Do not lift the door by the handle. Rough handling will cause glass to break.

Removing the oven door

Your oven is equipped with a door that can be disassembled in order to clean all the panes of glass. Remove the door before cleaning.

- Open the door fully to access the hinges then rotate the 'stirrups' (highlighted in the image) on both hinges fully towards the oven.

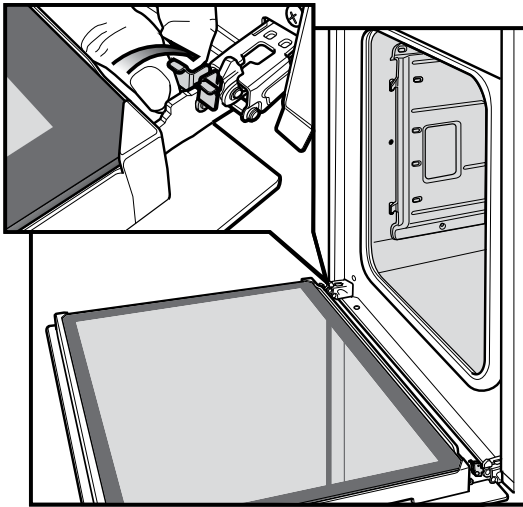

- Slowly close the oven door until it stops against the 'stirrups' (about 45°).

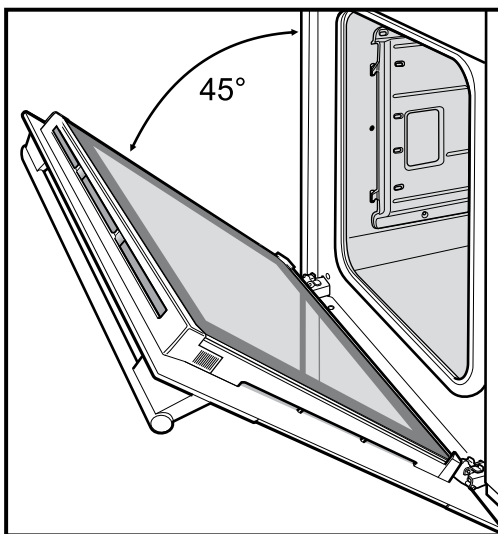

- Grasp the oven door with a hand each side of the door and remove it from the oven by pulling it towards you.

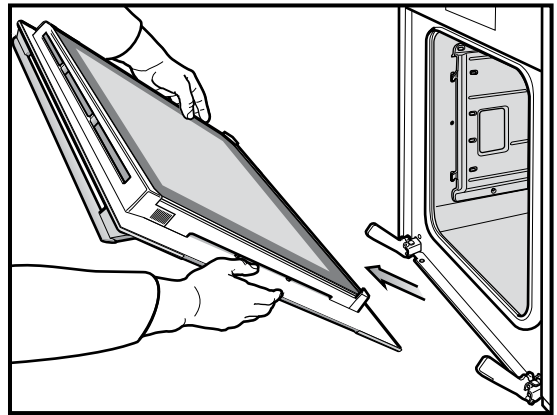

- Lay the oven door with the outer side facing downwards on something soft and flat (for example a blanket on a kitchen table) to prevent scratches.

Removing oven door top trim

- Take hold of the grid embossed sections of the door trim at each end and press inwards to release the clips. Remove the door trim by pulling it towards you.

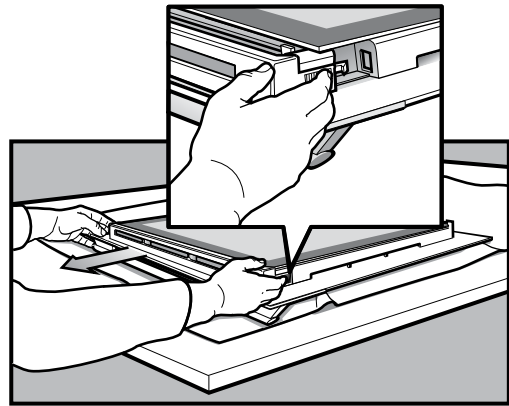

Removing door glass panels

! warning

Rough handling, especially around the edges can cause the glass to break.

- Lift the black bordered glass panel out of the guide.
- Repeat this for the smaller clear glass panel (when fitted).

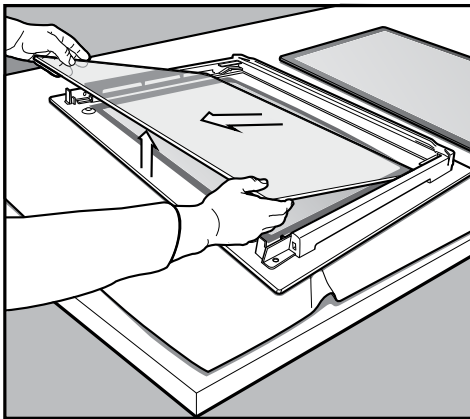
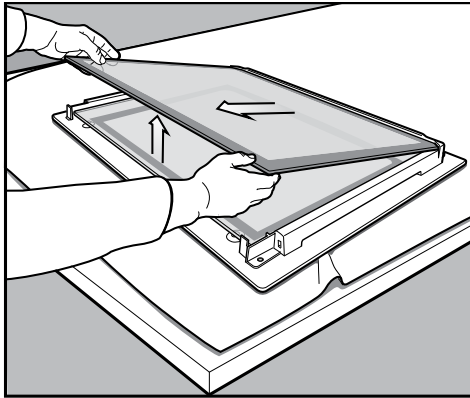

Re-assembling bottom trim

- Push down to “snap” each side of bottom trim back into door columns.

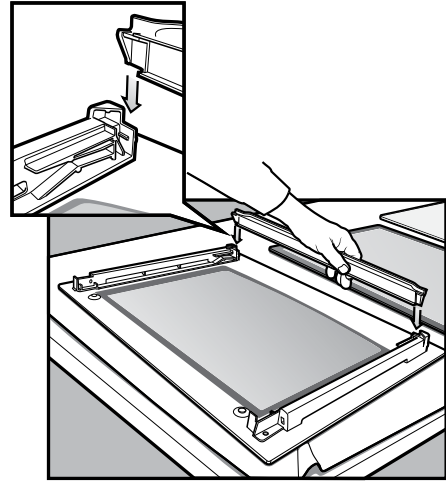

Re-assembling door glass panels

- Insert the smaller clear glass panel (when fitted) first from above and at an angle to the profile of the door.

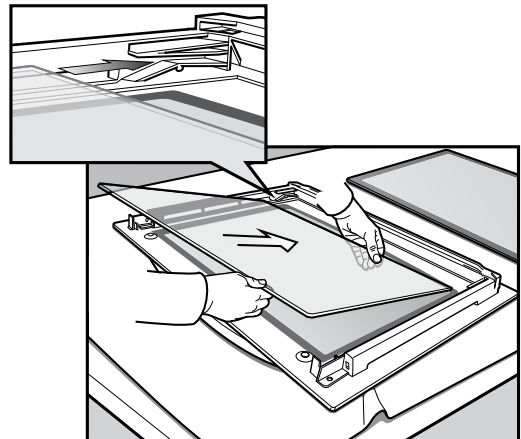

Cleaning door glass panels

warning

Do not to use harsh abrasives on the glass panes as the reflective surface plays a role in the function of the oven. Do not place glass in dishwasher. Hand wash only with a soft cloth and warm soapy water. When dry polish with a soft cloth and ensure the glass is dry before reassembly.

Bottom trim (on selected models)

- The bottom trim may be removed for cleaning by snapping out and lifting away from the glass.

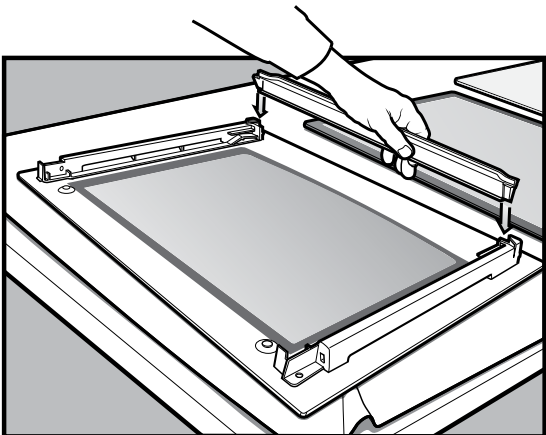

- Repeat for the black bordered glass panel ensuring the painted surface is facing to the downside.

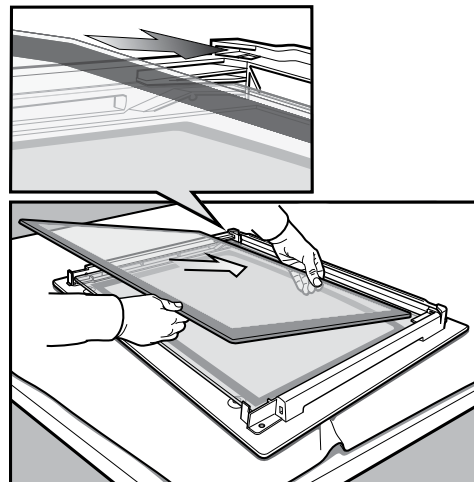

Re-assembling top door trim

- Take hold of the top door trim at each side and position it to the inside edge of the glass.
- Push the trim down with its top edge over glass panel until the clip snaps in on each side of the trim.

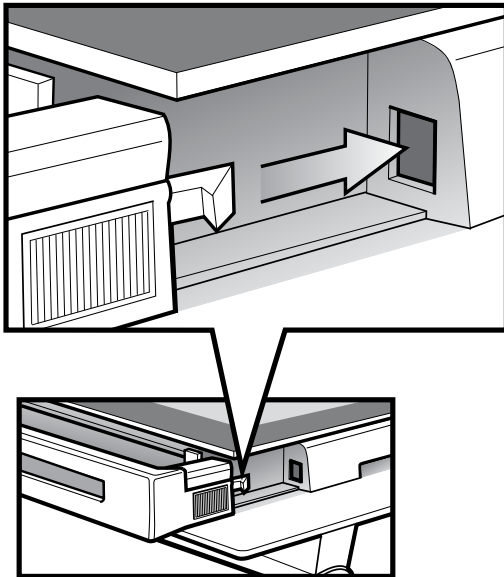

- Push the middle of the trim down to ensure it is straight and firm against the glass panel.

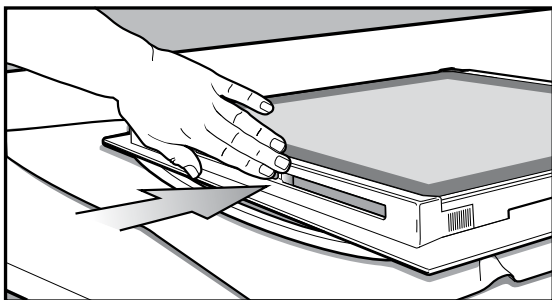

Fitting the oven door

- Take hold of the oven door with a hand on each side and with the door at an angle of 45°, position the recesses at the bottom of the door onto the hinge arms of the oven. Let the door slide down the hinge arms as far as it will go.

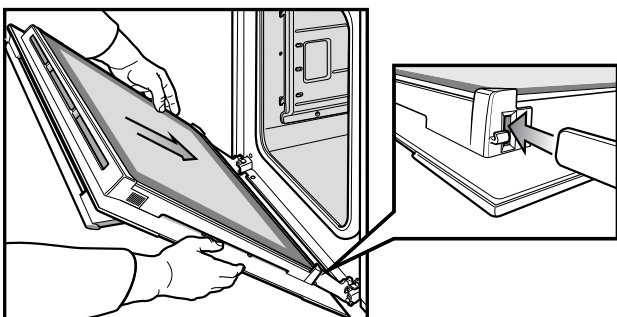

- Open the door fully to access the hinges then rotate the 'stirrups' (highlighted in the image) on both hinges back to their original positions. The oven door may now be closed.

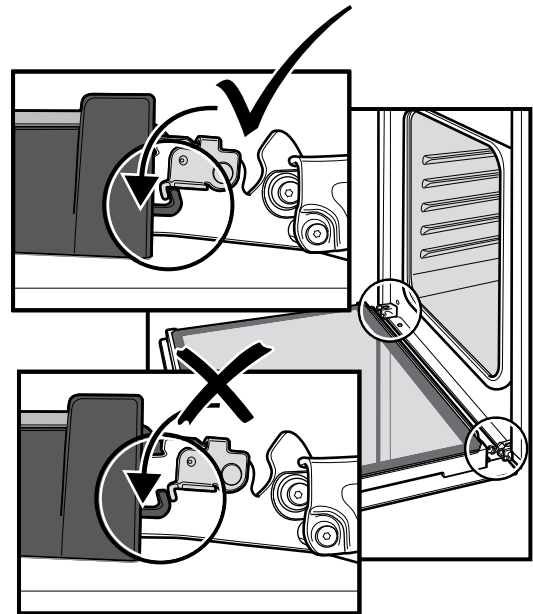

Removing side open door top trim

- Take hold of the grid embossed sections of the door trim at each end and press inwards to release the clips. Then remove the door trim by lifting it upwards.

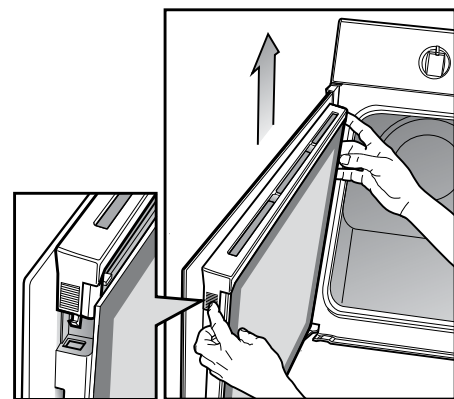

Removing side open door glass panel

warning

Rough handling, especially around the edges can cause the glass to break.

- Take hold of the black bordered glass panel with a hand on its upper and lower edge. Lift and rotate the glass around the retainer to remove it from the guide.

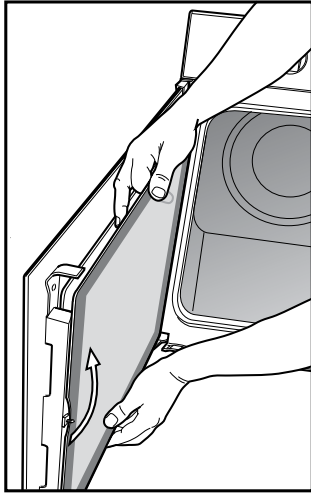

- Take hold of the smaller clear glass panel (when fitted) with a hand on its upper and lower edge. Lift the glass to remove it from the retainer.
- The rubber mouldings on the upper corners of the smaller clear glass panel may be removed. Don't misplace them.

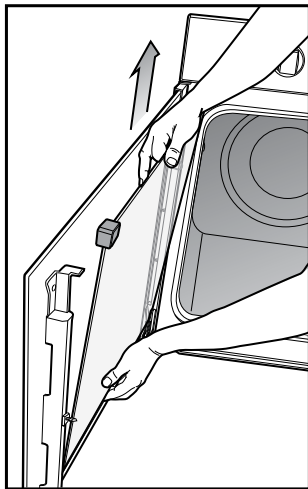

Cleaning door glass panels

warning

Do not to use harsh abrasives on the glass panes as the reflective surface plays a role in the function of the oven. Do not place glass in dishwasher. Hand wash only with a soft cloth and warm soapy water. When dry polish with a soft cloth and ensure the glass is dry before reassembly.

Re-assembling door glass panels

- Ensure the rubber mouldings are on the upper corners of the smaller clear glass panel.
- Insert the smaller glass panel (when fitted) first from above and at an angle to the profile of the door.

- Repeat for the black bordered glass panel ensuring the painted surface is facing toward the door.

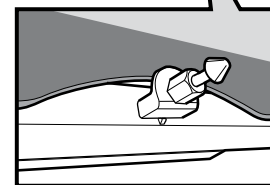
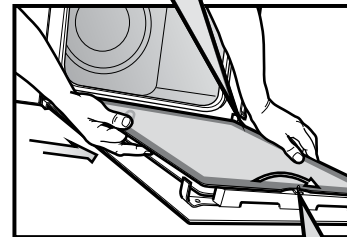
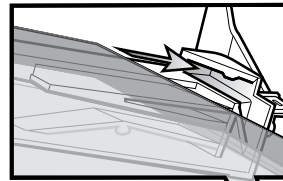

Replacing top door trim

- Take hold of the top door trim at each side and position it to the inside edge of the glass.
- Push the trim down with its top edge over glass panel until the clip snaps in on each side of the trim.

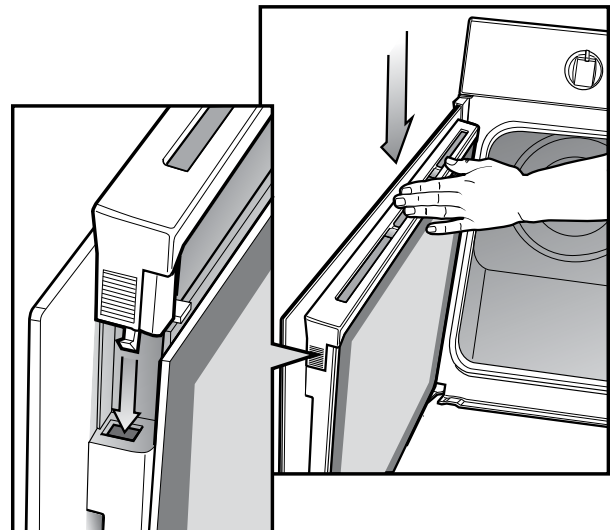

faults

If there is a problem with the oven and/or grill, please:

- Check the points listed below before calling for service.
It may be possible to avoid a call by fixing the problem yourself - and so continue cooking.
- For cooking problems refer to page 24.

NOTE: We may charge for service even in the guarantee period if your problem is due to the causes listed below.

| problem | possible cause |
|--|--|
| oven or grill not working | Time of day not set. |
| | Power not turned on. |
| | Controls are incorrectly set. |
| | Household fuse has blown or power supply is off. |
| | Child-proof oven lock activated. (Refer to operating instructions). |
| | <i>NOTE: If the household fuse continues to blow, call the Customer Care Centre.</i> |
| oven light not working | Lamp blown or loose in socket. |
| | Household fuse has blown. |
| | <i>NOTE: If the household fuse continues to blow, call the Customer Care Centre.</i> |
| oven not heating enough | Foil or trays on bottom of oven. |
| oven not working | Timer is in "AUTO" mode. (Refer to timer operating instructions) |
| | Household fuse has blown. |
| | <i>NOTE: If the household fuse continues to blow, call the Customer Care Centre.</i> |
| timer flashing on display | Power failure or interruption. |
| | <i>NOTE: If the household fuse continues to blow, call the Customer Care Centre.</i> |
| unit smoking when first used | Protective oils being removed. |
| condensation building up | Reduce amount of water used in cooking. (Some condensation is normal). |
| door cannot be replaced after removal | Stirrup not engaged properly. |

NOTE: Only authorised personnel should carry out servicing.

warning

USE AN AUTHORISED PERSON

As stated in the local municipal building codes and other relevant statutory regulations.

- Wiring connections must be in accordance with AS/NZS 3000 Wiring Rules and any particular conditions of the local authority.
- Refer to data plate for rating information and circuit diagram. The data plate is positioned behind the bottom of the oven door. The circuit diagram is positioned on the top panel of the appliance.
- For appliances with open cooking surfaces, an all pole disconnected functional switch should be provided near the appliance in an accessible position. Refer to AS/NZS 3000 clause 4.7.1
- Wiring should be protected against mechanical failure. Refer to AS/NZS 3000 clauses 3.3.2.6, 3.9, 3.10
- A means of disconnection with a contact separation of at least 3mm must be supplied in the fixed wiring.
- To gain access to the mains connection terminals, remove the rear access cover by unscrewing the 2 screws.
- If the supply cord is damaged, it must be replaced by the manufacturer, its service agent or similarly qualified persons in order to avoid a hazard.
- For appliances fitted with a supply flexible cord, if the cord is damaged, it must be replaced by the manufacturer or its service agent or similarly qualified person in order to avoid a hazard. The plug must be accessible after installation.

Multi-phase

Where connection is made to a multi-phase 220-240V supply, the bridge piece should be removed from between the active connections.

warning

IMPORTANT: This appliance must be properly earthed.

- Do not lift the appliance by the door handles.
- Prepare the cupboard opening to match your appliance measurements. (See diagrams on following pages).
- Slide appliance into the cupboard, ensuring that the supply cable (where fitted) does not kink.
- To prevent tipping, use the screws supplied to secure your oven into the cupboard. Use just 2 screws for single cavity ovens and 4 screws for dual cavity. Remove the bottom door in dual cavity ovens to provide access to the bottom 2 screwing points (see illustrations on page 30 and 32).
- For appliances fitted with a flexible supply cord, if the cord is damaged, it must be replaced by the manufacturer or its service agent or similarly qualified person in order to avoid a hazard. The plug must be accessible after installation.
- Where the appliance is built into a cabinet, the cabinet material must be capable of withstanding 70°C. Installation into low temperature tolerant cabinetry (e.g. vinyl coated) may result in deterioration of the low temperature coating by discolouring or bubbling.
- If the appliance is installed adjacent to vinyl-wrapped surfaces, use an installation kit available from the vinyl-wrap supplier.
- Electrolux Home Products cannot accept responsibility for damage caused by installation into low temperature tolerant cabinets.
- After installation, test and ensure that the appliance operates correctly before handing it over to the customer.

caution

To avoid any potential hazard, you must follow our instructions below when you install your appliance. Failure to install the appliance correctly could invalidate any warranty or liability claims and lead to prosecution.

cabinet construction for your appliance

For the best integration within a kitchen, install this appliance in a standard 600mm wide cupboard that gives a flush fit with the surrounding cupboard fronts (figure A). A recess of 20 mm is ideal. It can also be installed using a proud fit with the surrounding cupboard (figure B).

NOTE: Your appliance must be mounted on a flat surface for the full width and depth of the product.

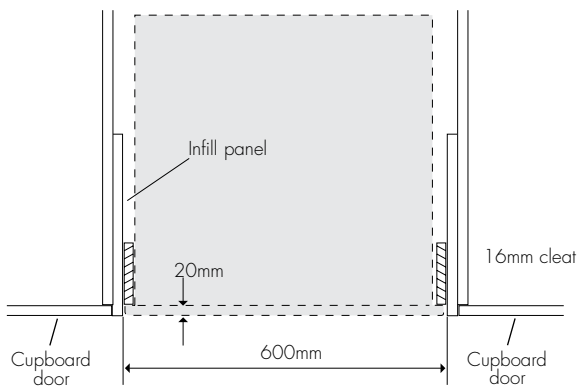

Figure A - Flush fit (top view)

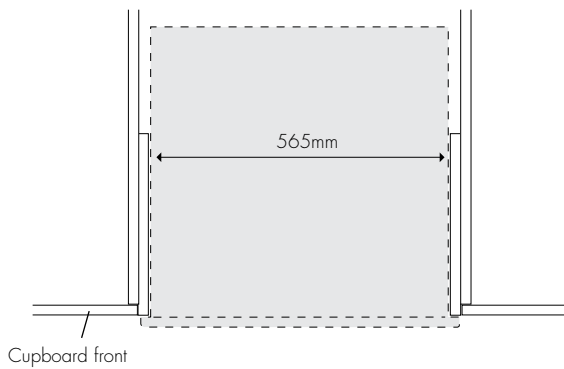
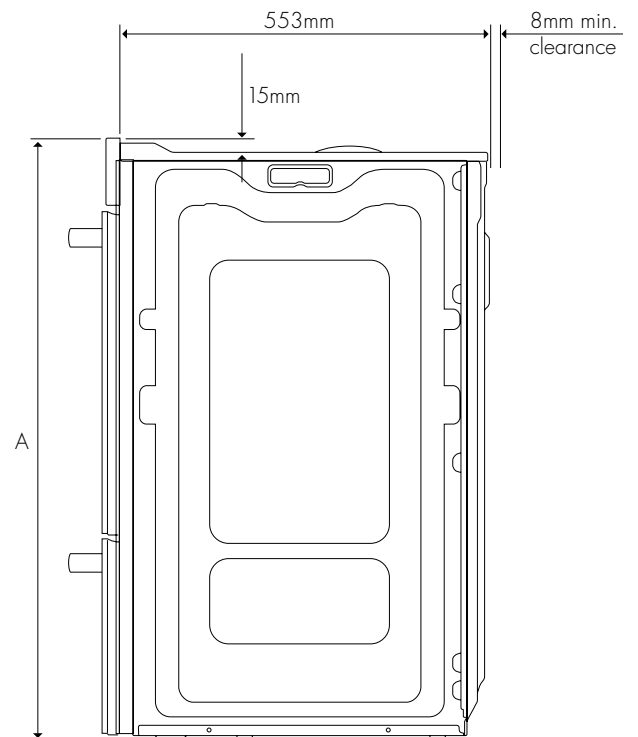

Figure B - Proud fit (top view)

oven dimensions

| oven | height (A) |
|--------------------------------|------------|
| Underbench oven | 595mm |
| Separate grill underbench oven | 725mm |
| Separate grill wall oven | 888mm |
| Duo oven | 888mm |
| Double oven | 1083mm |

All built-in ovens are 595mm wide



underbench ovens

Your underbench oven looks best when the control panel is directly under the benchtop. An upper infill panel may have to be added if the cooktop placed above the benchtop is too deep. Refer to cooktop installation instructions for required clearance between cooktop and oven.

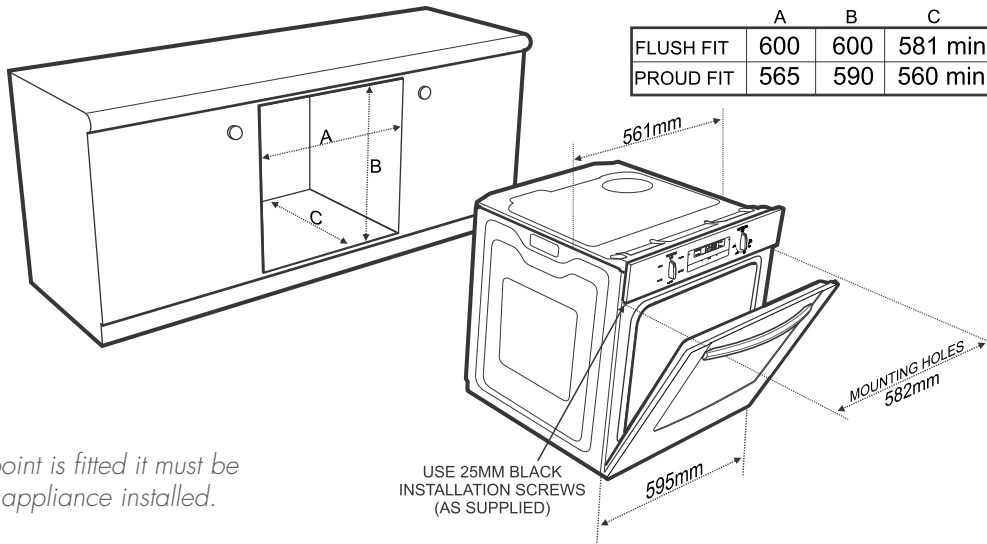

NOTE: If a powerpoint is fitted it must be accessible with the appliance installed.

separate grill wall oven & duo oven

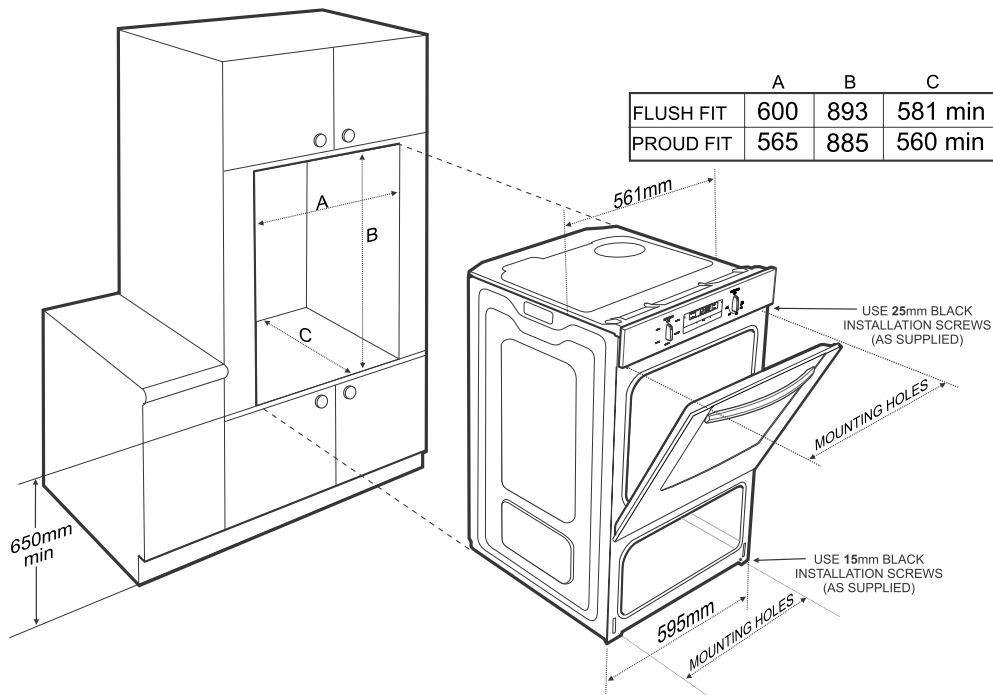

separate grill underbench ovens

| | A | B | C |
|-----------|-----|-----|---------|
| FLUSH FIT | 600 | 731 | 581 min |
| PROUD FIT | 565 | 723 | 560 min |

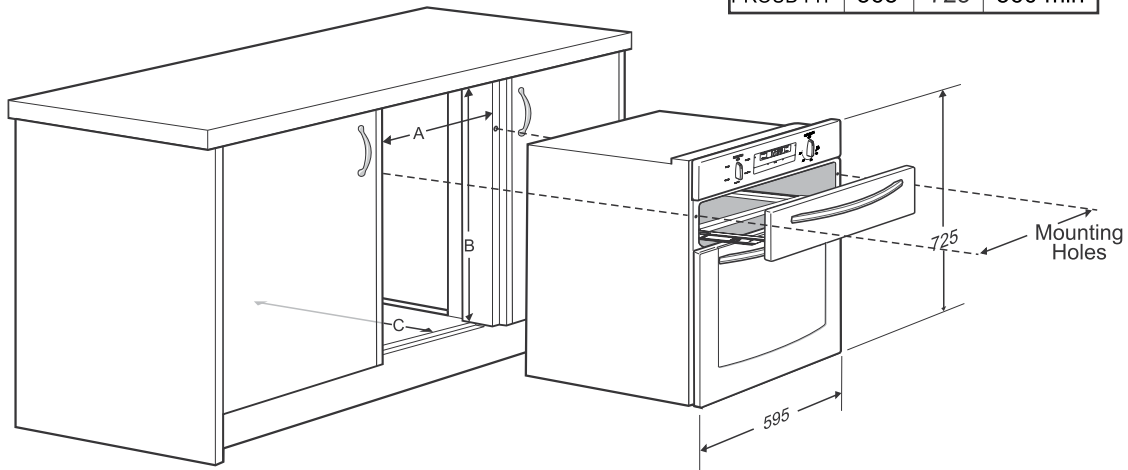

recommended cabinet design

NOTE TO INSTALLER: For Separate Grill Underbench Installations where a Cooktop is installed directly above the appliance, a minimum clearance distance of 10mm must be allowed for between the bottom of the cooktop & the top of the Separate Grill Underbench Oven.

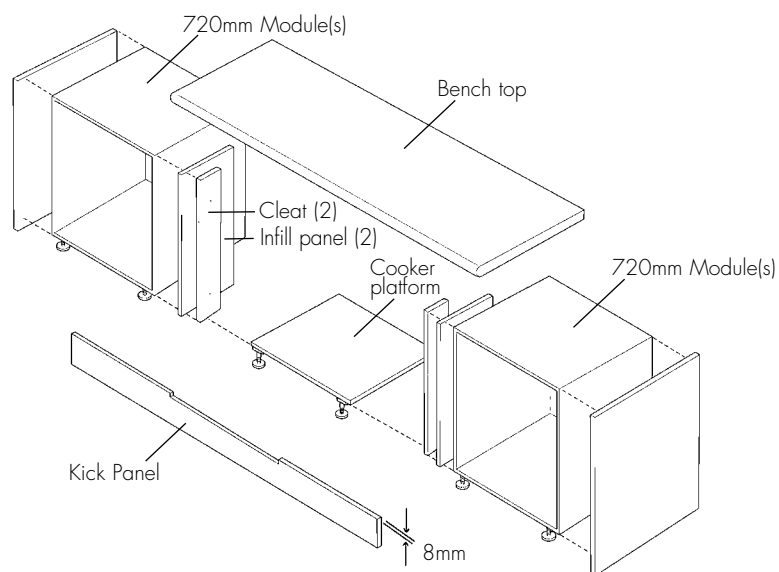

Supporting shelf 8mm below door line to give perfect alignment of cooker & cupboard (kickboard notched to suit).

double ovens

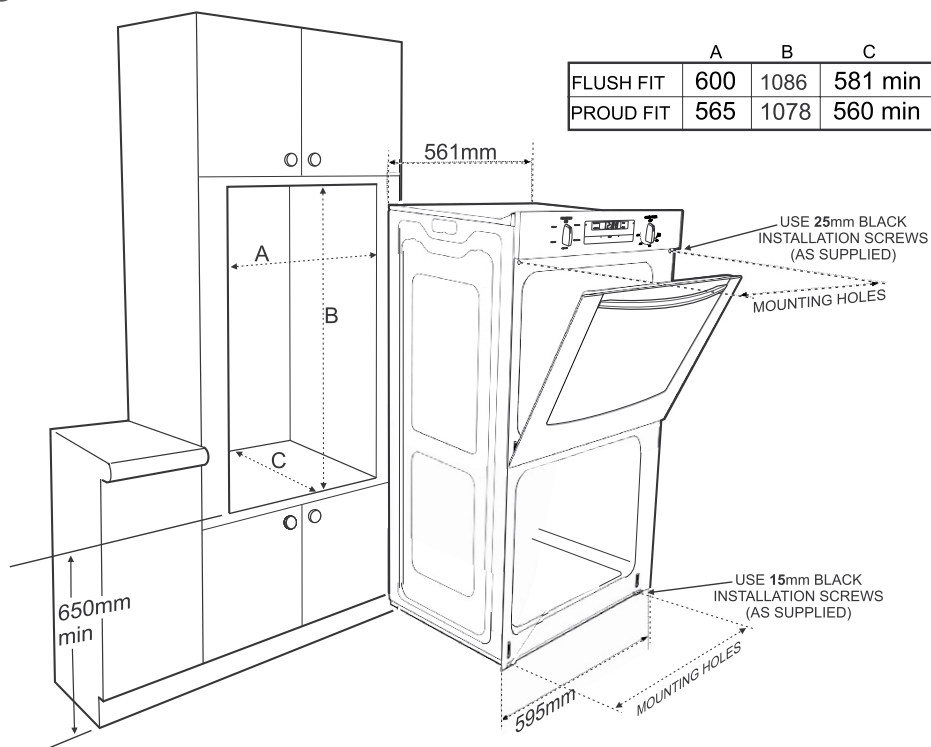

NOTE: For double oven models, only the lower termination point is to be connected.

side opening door ovens

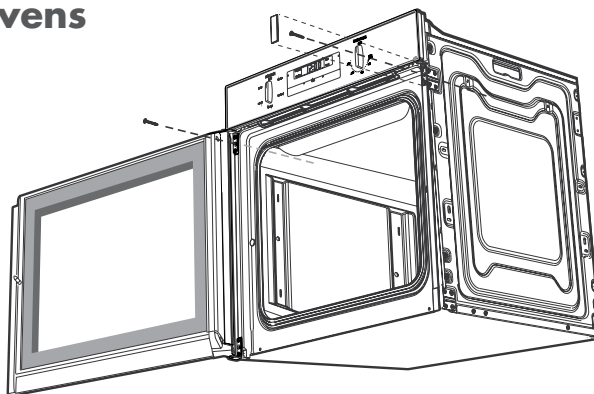

hard wiring detail

1. Remove terminal cover plate from rear panel of appliance.
2. Fit wires through hole in cover plate and make connections to terminals.
3. Engage wires into plastic clip. Secure plastic clip with two long silver screws (supplied in separate bag).
4. Replace cover plate onto rear panel.

NOTE: Double oven (Model PDP794). This product is supplied with two optional termination points. Only one termination point is required to be connected.

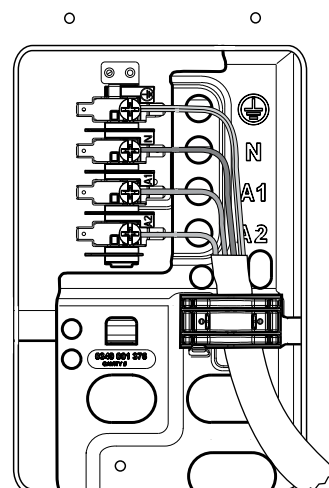

cooktop cut-out dimensions (combo models)

Cooktop dimensions

| | overall cooktop dimensions |
|---------------|----------------------------|
| width | 610mm |
| depth | 515mm |
| depth of base | 45mm |

Cooktop cut-out dimensions

| | A | B |
|---------|-------|-------|
| cooktop | 560mm | 490mm |

A minimum gap of 40mm must be maintained between the top of the underbench oven and the bottom of the cooktop to ensure adequate ventilation and space for the interconnection lead.

important

THE COOKTOP MUST BE INSTALLED DIRECTLY ABOVE THE UNDERBENCH OVEN

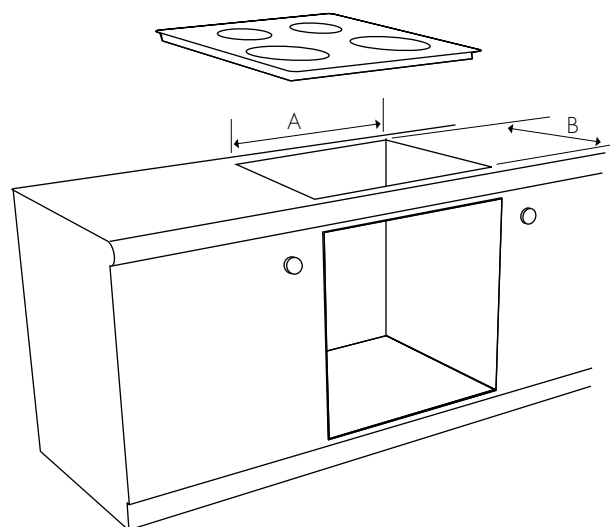

Electrolux Warranty

FOR SALES IN AUSTRALIA AND NEW ZEALAND
APPLIANCE: BUILT-IN OVEN, COOKTOP
AND FREESTANDING COOKER

This document sets out the terms and conditions of the product warranties for Electrolux Appliances. It is an important document. Please keep it with your proof of purchase documents in a safe place for future reference should you require service for your Appliance.

1. In this warranty
 - (a) 'acceptable quality' as referred to in clause 10 of this warranty has the same meaning referred to in the ACL;
 - (b) 'ACL' means Trade Practices Amendment (Australian Consumer Law) Act (No.2) 2010;
 - (c) 'Appliance' means any Electrolux product purchased by you accompanied by this document;
 - (d) 'ASC' means Electrolux' authorised serviced centres;
 - (e) 'Electrolux' means Electrolux Home Products Pty Ltd of 163 O'Riordan Street, Mascot, NSW 2020, ABN 51 004 762 341 in respect of Appliances purchased in Australia and Electrolux (NZ) Limited of 3-5 Niall Burgess Road, Mount Wellington, in respect of Appliances purchased in New Zealand;
 - (f) 'major failure' as referred to in clause 10 of this warranty has the same meaning referred to in the ACL and includes a situation when an Appliance cannot be repaired or it is uneconomic for Electrolux, at its discretion, to repair an Appliance during the Warranty Period;
 - (g) 'Warranty Period' means:
 - (i) where the Appliance is used for personal, domestic or household use (i.e. normal single family use) as set out in the instruction manual, the Appliance is warranted against manufacturing defects in Australia for 24 months and in New Zealand for 24 months, following the date of original purchase of the Appliance;
 - (ii) where the Appliance is used for commercial purposes (including being used to directly assist a business or where the Appliance is used in a multi-family communal or share type environment), the Appliance will then be warranted against manufacturing defects in Australia for 3 months and in New Zealand for 3 months, following the date of original purchase of the Appliance.
 - (h) 'you' means the purchaser of the Appliance not having purchased the Appliance for re-sale, and 'your' has a corresponding meaning.
2. This warranty only applies to Appliances purchased and used in Australia or New Zealand and is in addition to (and does not exclude, restrict, or modify in any way) any non-excludable statutory warranties in Australia or New Zealand.
3. During the Warranty Period Electrolux or its ASC will, at no extra charge if your Appliance is readily accessible for service, without special equipment and subject to these terms and conditions, repair or replace any parts which it considers to be defective. Electrolux or its ASC may use remanufactured parts to repair your Appliance. You agree that any replaced Appliances or parts become the property of Electrolux. This warranty does not apply to light globes, batteries, filters or similar perishable parts.
4. Parts and Appliances not supplied by Electrolux are not covered by this warranty.
5. You will bear the cost of transportation, travel and delivery of the Appliance to and from Electrolux or its ASC. If you reside outside of the service area, you will bear the cost of:
 - (a) travel of an authorised representative;
 - (b) transportation and delivery of the Appliance to and from Electrolux or its ASC,

In all instances, unless the Appliance is transported by Electrolux or an Electrolux authorised representative, the Appliance is transported at the owner's cost and risk while in transit to and from Electrolux or its ASC.
6. Proof of purchase is required before you can make a claim under this warranty.
7. You may not make a claim under this warranty unless the defect claimed is due to faulty or defective parts or workmanship. Electrolux is not liable in the following situations (which are not exhaustive):
 - (a) the Appliance is damaged by:
 - (i) accident
 - (ii) misuse or abuse, including failure to properly maintain or service
 - (iii) normal wear and tear
 - (iv) power surges, electrical storm damage or incorrect power supply
 - (v) incomplete or improper installation
 - (vi) incorrect, improper or inappropriate operation
 - (vii) insect or vermin infestation
 - (viii) failure to comply with any additional instructions supplied with the Appliance;
 - (b) the Appliance is modified without authority from Electrolux in writing;
 - (c) the Appliance's serial number or warranty seal has been removed or defaced;
 - (d) the Appliance was serviced or repaired by anyone other than Electrolux, an authorised repairer or ASC.
8. This warranty, the contract to which it relates and the relationship between you and Electrolux are governed by the law applicable where the Appliance was purchased. Where the Appliance was purchased in New Zealand for business purposes the Consumer Guarantee Act does not apply.
9. To the extent permitted by law, Electrolux excludes all warranties and liabilities (other than as contained in this document) including liability for any loss or damage whether direct or indirect arising from your purchase, use or non use of the Appliance.
10. For Appliances and services provided by Electrolux in Australia, the Appliances come with a guarantee by Electrolux that cannot be excluded under the Australian Consumer Law. You are entitled to a replacement or refund for a major failure and for compensation for any other reasonably foreseeable loss or damage. You are also entitled to have the Appliance repaired or replaced if the Appliance fails to be of acceptable quality and the failure does not amount to a major failure. The benefits to you given by this warranty are in addition to your other rights and remedies under a law in relation to the Appliances or services to which the warranty relates.
11. At all times during the Warranty Period, Electrolux shall, at its discretion, determine whether repair, replacement or refund will apply if an Appliance has a valid warranty claim applicable to it.
12. For Appliances and services provided by Electrolux in New Zealand, the Appliances come with a guarantee by Electrolux pursuant to the provisions of the Consumer Guarantees Act, the Sale of Goods Act and the Fair Trading Act.
13. To enquire about claiming under this warranty, please follow these steps:
 - (a) carefully check the operating instructions, user manual and the terms of this warranty;
 - (b) have the model and serial number of the Appliance available;
 - (c) have the proof of purchase (eg an invoice) available;
 - (d) telephone the numbers shown below.
14. You accept that if you make a warranty claim, Electrolux and its ASC may exchange information in relation to you to enable Electrolux to meet its obligations under this warranty.

Important Notice

Before calling for service, please ensure that the steps listed in point 13 above have been followed.

| | | |
|--|---|--|
| <p>FOR SERVICE or to find the address of your nearest state service centre in Australia PLEASE CALL 13 13 49 For the cost of a local call (Australia only)</p> | <p>SERVICE AUSTRALIA  ELECTROLUX HOME PRODUCTS www.electrolux.com.au</p> | <p>FOR SPARE PARTS or to find the address of your nearest state spare parts centre in Australia PLEASE CALL 13 13 50 For the cost of a local call (Australia only)</p> |
| <p>FOR SERVICE or to find the address of your nearest authorised service centre in New Zealand FREE CALL 0800 10 66 10 (New Zealand only)</p> | <p>SERVICE NEW ZEALAND  ELECTROLUX HOME PRODUCTS www.electrolux.co.nz</p> | <p>FOR SPARE PARTS or to find the address of your nearest state spare parts centre in New Zealand FREE CALL 0800 10 66 20 (New Zealand only)</p> |

P/No: 0342 001 572 Issue A ECN: 11A086G

© 2011 Electrolux Home Products Pty Ltd

ABN 51 004 762 341

Print code: WMAN_Gen_Export_UM_Jun11

