



Elcold Frysere Hobro ApS
Løgstørvej 81 Hørby 9500 Hobro Denmark
Phone +45 9657 2222 Fax +45 9852 4685
Email elcold@elcold.com www.elcold.com



i.c. graphics cph





User Instructions

Lab* Frost



Ultra Low Temperature Freezers Model LAB

SAFETY INFORMATIONS

The LAB freezers contains environmentally friendly but flammable refrigerants. It means danger of explosion if for any reason the refrigerants are allowed to escape from the system.

The refrigeration system must never be accessed by unauthorized personal.

When transporting and installing the unit, ensure that no part of the tubing system is damaged.

If the tubing is damaged and leak occurs, avoid any ignition sources and naked flames near the unit, and ventilate the room immediately.

In order to avoid formation of flammable gas/air mixtures in case of a leak from the refrigeration system, the room where the unit is placed must have a volume equivalent to 1m³ per 8 gr. of refrigerant in the cabinet.

WARNING!!!

The ventilation openings must never be covered or blocked.

Never use a stream or water cleaning device during cleaning or defrosting in order to avoid short circuits in the electrical system.

Do not place any electrical devices in the freezer.

Products containing flammable gasses and explosives must not be stored in the freezer.

All units should be provided with installation and operating instructions. In addition to the Clearances Installation, the instructions should contain such directions and information that the manufacturer considers necessary for installation, maintenance, and use of the refrigerator.

Installation and operating instructions should be provided with cautionary statements concerning the handling, moving, and use of the refrigerator or freezer to avoid either damaging the refrigerant tubing, or increasing the risk of a leak.

The shipping carton of a refrigerator or freezer that employs a flammable refrigerant should be marked

"Caution - Risk of Fire or Explosion due to Flammable Refrigerant Used. Follow Handling Instructions Carefully in Compliance with U.S. Government Regulations".

The warning marking should also appear on the shipping carton, see below.



The installation and operating instructions should indicate that component parts shall be replaced with like components and that servicing shall be done by factory authorized service personnel, so as to minimize the risk of possible ignition due to incorrect parts or improper service.



USER INSTRUCTIONS

Congratulations with your new freezer, we feel certain that it will be very useful to you for many years ahead. To obtain optimal benefit from your freezer, please read the following instructions thoroughly and act accordingly. The low-temperature freezers are used for freezing and long-term storing of food products, medical preparations (vaccines, blood plasm, ect.) and other biological products.

1. Environmental protection and disposal

The packaging is designed to protect the appliance and its components during transportation, and it is made of recyclable materials.

- Please return the packaging to an official collection point for recycling.
- Old appliances contain reusable materials and should not be disposed of together with household refuse.
- Remove the spring-action hinges from the appliance, in order to prevent children from being entrapped in the appliance.
- Ensure that no part of the refrigeration tubing is damaged as the refrigerant in the appliance risks escaping to the environment.
- Information about refrigerant type and amount will be found on the type plate on the rear of the appliance (Fig. 1).

2. Safety instructions

- In order to prevent injuries and or damage to the appliance, it should be unpacked and set up by min. two people.
- If upon unpacking the appliance is found damaged, do not connect to the mains, but contact the supplier.
- ***Interference with or repair to the appliance should only be carried out by authorized personnel, in order to avoid any injuries.***

(Contact the supplier for further information).

- Never put naked flames or other ignition sources inside the appliance.
- Never touch the freezers interior or products in the freezer when the freezer is operating. Use gloves or alike in order to avoid injuries (frost-bite).
- Keep the key to the appliance away from the appliance and out of the reach of children.

3. Connection to the mains

- For safety reasons, the appliance must be earthed. If you are in any doubt, please contact an authorized electrician.
- The appliance should be left for 5 hours before it is connected to the mains. If the appliance is connected before that, there is a risk of damaging the compressor.
- If for any reason the appliance is disconnected from the mains, please wait 10 minutes before re-connecting. The electronic starting device needs this time to cool down, before a safe re-start can be made.

4. Before use

- Before use, the interior of the appliance should be cleaned with a mild soap solution, and wiped off with a dry clean cloth. Never use any kind of solvent or other chemicals

5. Setting up the freezer

The freezer should not be placed where it might be splashed with water, in extreme high humidity or in direct sunlight. Any of these factors may lead to a reduction in performance and shorten the life span of the components. The freezer should be placed on a horizontal level, and should not be placed close to a heating appliance or heating tubes. Allow a minimum of 50mm (2") clearance on the side and the back.

The side with the ventilation grill should have a clearance of at least 100 mm (4") in order to



allow the heat from the compressor motor to dissipate. Underneath the appliance these should be a gap of 15 mm approx. (1/2"). On a soft surface, e.g. carpet, it may be necessary to ensure the correct distance by means of spacers.

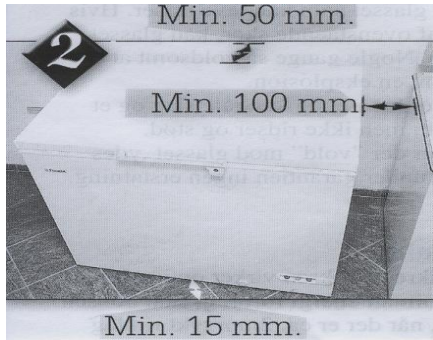

6. Electrical supply

The electrical supply should always be in accordance with the rating plate on the back of the freezer.

The supply must always be in accordance with the law and regulations regarding electrical safety.

If any doubts, contact your supplier.

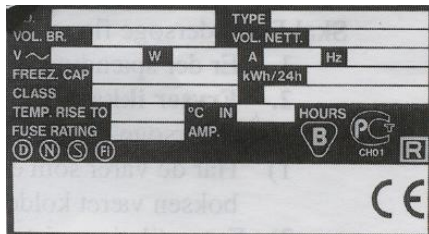

Fig. 1

7. Starting Up

In case the compressor does not start when the freezer has been plugged in, the electrical supply may not be in order. Check if there is an electricity supply to the plug or if the fuse is blown. If not please go to trouble shooting page 5.

8. Operating the freezer

The empty freezer should be switched on for at least 5-6 hours prior to loading of the freezer.

The freezer should not be loaded above the inside walls which is also the load line limit.

Please note: After the lid has been opened, there will be a vacuum created inside the freezer due to the low temperatures. Wait a few minutes before trying to re-open the lid otherwise the handle could be damaged.

9. Defrosting

In order for the freezer to work to its maximum efficiency the cabinet should be defrosted when a approx. 2mm thick ice layer has formed inside the cabinet.

The ice layer is easily removed with a plastic or wooden scraper.

Never use a sharp metal object which might will cause damage to the inner liner.

The defrosting frequency is determined mainly by two factors the usage pattern (number of lid openings) and the relative humidity.

Excess water can be drained out by using the drain water outlet on the front of the freezer.

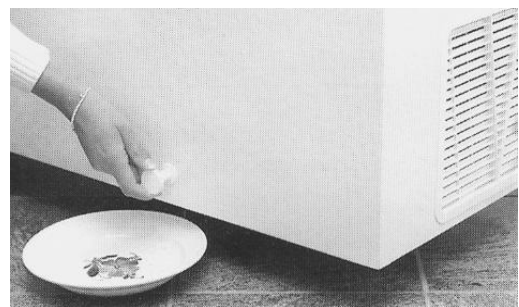

10. Cleaning

Cleaning should be done when needed.

When used in a dirty environment it might be necessary to remove the compressor

compartment grill, and clean the compressor compartment eventually with a vacuum cleaner.

If the cleaning process is neglected there is a risk that the performance of the freezer will be effected, and even damage to the compressor could occur due to overheating.

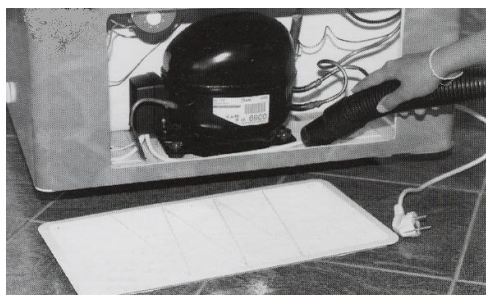

11. Storage

If the freezer is stored for a period of the time, the lid should be kept open for free circulation of air inside the cabinet in order to avoid corrosion of the inner liner.

12. Temperature control LAB freezers

The temperature inside the freezer is controlled by the electronic controller placed in the front grill.

The controller has a digital readout of the temperature inside the cabinet, and the option of changing the temperature inside the cabinet.

13. External voltage and temperature alarm

Optionally the freezer can be equipped with a battery operated alarm box with connections for external alarm for voltage failure and temperature alarm. The battery should be exchanged every two years.

Please note! When commissioning the freezer, the battery must be turned into its correct position.

14. Dixell controller



15. Functions

How to see the set point:

1. Press and immediately release the SET key, the display will now show the set point value.
2. Press and immediately release the SET key or wait for 5 seconds to display the probe value again.

How to lock and unlock the keyboard:

1. Press the up and down keys simultaneously for more than 3 seconds.

How to change the set point:

1. Press the SET key for more than 3 seconds to change the set point value.
2. The set point value will be displayed and the LED starts flashing.
3. To change the set point value, push the up or down arrow.
4. To memorise the new setting press the SET key again or wait 15 seconds for the controller to return to normal display of the probe temperature.

16. Setting the controllers offset value

The freezer is designed for long time and safe storage of sensitive food products.

In some situations, the LAB freezer is also used for other applications like in laboratories for different low temperature test.

Depending on the actual situation it might be necessary to change the controllers offset

value in order to get a correspondence between the reading on the display and the actual temperature inside the cabinet.

The offset can be adjusted in the following way:

Unlock the keyboard.

Enter the programming mode by pressing the SET and arrow down keys for 3 seconds.

Select the parameter “Ot” by pressing arrow up or down key.

Press the SET key to display its value.

Use arrow up or down to change its value. The offset can be adjusted to +/- 12 dgr.C

Press SET to store the new value.

Press SET + arrow up or wait 15 seconds without pressing any key. The new value will now be stored.

For more detailed information about programming the Dixell controllers please consult the attached manuals.

17. Trouble shooting

The appliance is not operating. Please check the following before calling for service:

Is the electrical plug connected to the mains (wall socket)? Is the fuse blown?

The appliance is operating continuously. Please check:

*Is ambient temperature too high?
Has the appliance recently been loaded with a large of warm products?*

The temperature inside the appliance is too high. Please check:

Is the Dixell controller set to the correct temperature?

Has an excess amount of ice formed inside the appliance?

If you have checked the above points and the appliance is still not working as expected, please contact your local dealer for further advice.

18. LN₂ or LCO₂ back-up

On the rear side of the cabinet there is a label and a marking, where it is possible to insert either a temperature probe or a back-up LN₂ or LCO₂ supply.

The inner and outer skins are pre-drilled.

IMPORTANT NOTE !!!

Do not attempt to drill or in other way make access to the freezers interior other places than at the marking, there is a risk of damaging the freezers tubing system, resulting in a leakage with inflammable gasses.

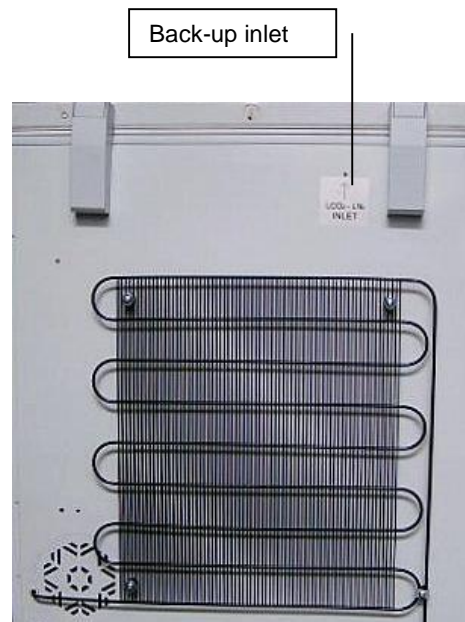

Digital controller with off cycle defrost and AUX relay XR30CH

CONTENTS

1. GENERAL WARNING	6
2. GENERAL DESCRIPTION	6
3. CONTROLLING LOADS	6
4. FRONT PANEL COMMANDS	6
5. MAX & MIN TEMPERATURE MEMORIZATION	6
6. MAIN FUNCTIONS	6
7. PARAMETERS	7
8. DIGITAL INPUT (ENABLED WITH P3P = N)	8
9. TTL SERIAL LINE – FOR MONITORING SYSTEMS	8
10. X-REP OUTPUT – OPTIONAL	8
11. INSTALLATION AND MOUNTING	8
12. ELECTRICAL CONNECTIONS	8
13. HOW TO USE THE HOT KEY	9
14. ALARM SIGNALS	9
15. TECHNICAL DATA	9
16. CONNECTIONS	9
17. FACTORY SETTINGS DIXELL XR30CH	10

1. GENERAL WARNING

1.1 PLEASE READ BEFORE USING THIS MANUAL

- This manual is part of the product and should be kept near the instrument for easy and quick reference.
- The instrument shall not be used for purposes different from those described hereunder. It cannot be used as a safety device.
- Check the application limits before proceeding.
- Dixell Srl reserves the right to change the composition of its products, even without notice, ensuring the same and unchanged functionality.

1.2 SAFETY PRECAUTIONS

- Check the supply voltage is correct before connecting the instrument.
- Do not expose to water or moisture: use the controller only within the operating limits avoiding sudden temperature changes with high atmospheric humidity to prevent formation of condensation
- Warning: disconnect all electrical connections before any kind of maintenance.
- Fit the probe where it is not accessible by the End User. The instrument must not be opened.
- In case of failure or faulty operation send the instrument back to the distributor or to "Dixell S.r.l." (see address) with a detailed description of the fault.
- Consider the maximum current which can be applied to each relay (see Technical Data).
- Ensure that the wires for probes, loads and the power supply are separated and far enough from each other, without crossing or intertwining.
- In case of applications in industrial environments, the use of mains filters (our mod. FT1) in parallel with inductive loads could be useful.

2. GENERAL DESCRIPTION

Model **XR30CH**, format 32 x 74 mm, is a digital thermostat with off cycle defrost designed for refrigeration applications at normal temperature. It provides two relay outputs, one for the compressor, the other one can be used as light, for alarm signalling or as auxiliary output.

It is also provided with 2 NTC or PTC probe inputs, the first one for temperature control, the second one, optional, to connect to the HOT KEY terminals to signal the condenser temperature alarm or to display a temperature. The digital input can operate as third temperature probe.

The HOT KEY output allows to connect the unit, by means of the external module XJ485-CX, to a network line **ModBUS-RTU** compatible such as the dIXEL monitoring units of X-WEB family. It allows to program the controller by means the HOT KEY programming keyboard.

The instrument is fully configurable through special parameters that can be easily programmed through the keyboard.

3. CONTROLLING LOADS

3.1 COMPRESSOR

The regulation is performed according to the temperature measured by the thermostat probe with a positive differential from the set point: if the temperature increases and reaches set point plus differential the compressor is started and then turned off when the temperature reaches the set point value again.

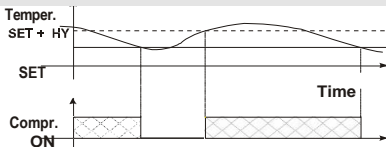

In case of fault in the thermostat probe the start and stop of the compressor are timed through parameters "**CO_n**" and "**CO_F**". Defrost is performed through a simple stop of the compressor. Parameter "**IdF**" controls the interval between defrost cycles, while its length is controlled by parameter "**MdF**".

4. FRONT PANEL COMMANDS



SET: To display target set point; in programming mode it selects a parameter or confirm an operation.

(DEF) To start a manual defrost

(UP): To see the max. stored temperature; in programming mode it browses the parameter codes or increases the displayed value.

(DOWN): To see the min stored temperature; in programming mode it browses the parameter codes or decreases the displayed value.

To switch the instrument off, if onF = oFF.

To switch the light, if oA1 = Lig

KEY COMBINATIONS:

To lock & unlock the keyboard.

SET + To enter in programming mode.

SET + To return to the room temperature display.

4.1 USE OF LEDS

Each LED function is described in the following table.

LED	MODE	FUNCTION
	ON	Compressor enabled
	Flashing	Anti-short cycle delay enabled
	ON	Defrost enabled
	ON	An alarm is occurring
	ON	Continuous cycle is running
ECO	ON	Energy saving enabled
	ON	Light on
AUX	ON	Auxiliary relay on
°C/°F	ON	Measurement unit
°C/°F	Flashing	Programming phase

5. MAX & MIN TEMPERATURE MEMORIZATION

5.1 HOW TO SEE THE MIN TEMPERATURE

1. Press and release the key.
2. The "Lo" message will be displayed followed by the minimum temperature recorded.
3. By pressing the key again or by waiting 5s the normal display will be restored.

5.2 HOW TO SEE THE MAX TEMPERATURE

1. Press and release the key.
2. The "Hi" message will be displayed followed by the maximum temperature recorded.
3. By pressing the key again or by waiting 5s the normal display will be restored.

5.3 HOW TO RESET THE MAX AND MIN TEMPERATURE RECORDED

1. Hold press the SET key for more than 3s, while the max. or min temperature is displayed. (rSt message will be displayed)
2. To confirm the operation the "rSt" message starts blinking and the normal temperature will be displayed.

6. MAIN FUNCTIONS

6.1 HOW TO SEE THE SETPOINT

1. Push and immediately release the **SET** key: the display will show the Set point value.
2. Push and immediately release the **SET** key or wait for 5 seconds to display the probe value again.

6.2 HOW TO CHANGE THE SETPOINT

1. Push the **SET** key for more than 2 seconds to change the Set point value.
2. The value of the set point will be displayed and the "°C" or "°F" LED starts blinking;
3. To change the Set value push the ▲ or ▼ arrows within 10s.
4. To memorise the new set point value push the **SET** key again or wait 10s.

6.3 HOW TO START A MANUAL DEFROST



Push the **DEF** key for more than 2 seconds and a manual defrost will start.

6.4 HOW TO CHANGE A PARAMETER VALUE

To change the parameter's value operate as follows:

1. Enter the Programming mode by pressing the **Set + ▼** keys for 3s (the "°C" or "°F" LED starts blinking).
 2. Select the required parameter. Press the "**SET**" key to display its value
 3. Use "**UP**" or "**DOWN**" to change its value.
 4. Press "**SET**" to store the new value and move to the following parameter.
- To exit:** Press **SET + UP** or wait 15s without pressing a key.
NOTE: the set value is stored even when the procedure is exited by waiting the time-out to expire.

6.5 THE HIDDEN MENU

The hidden menu Includes all the parameters of the instrument.

6.5.1 HOW TO ENTER THE HIDDEN MENU

1. Enter the Programming mode by pressing the **Set + ▼** keys for 3s (the "°C" or "°F" LED starts blinking).
2. Released the keys, then push again the **Set + ▼** keys for more than 7s. The Pr2 label will be displayed immediately followed from the HY parameter.

NOW YOU ARE IN THE HIDDEN MENU

3. Select the required parameter.
 4. Press the "**SET**" key to display its value
 5. Use ▲ or ▼ to change its value.
 6. Press "**SET**" to store the new value and move to the following parameter.
- To exit:** Press **SET + ▲** or wait 15s without pressing a key.
NOTE1: if none parameter is present in Pr1, after 3s the "noP" message is displayed. Keep the keys pushed till the Pr2 message is displayed.

NOTE2: the set value is stored even when the procedure is exited by waiting the time-out to expire.

6.5.2 HOW TO MOVE A PARAMETER FROM THE HIDDEN MENU TO THE FIRST LEVEL AND VICEVERSA.

Each parameter present in the HIDDEN MENU can be removed or put into "THE FIRST LEVEL" (user level) by pressing "**SET + ▼**".
In HIDDEN MENU when a parameter is present in First Level the decimal point is on.

6.6 HOW TO LOCK THE KEYBOARD

1. Keep pressed for more than 3 s the **UP + DOWN** keys.
2. The "POF" message will be displayed and the keyboard will be locked. At this point it will be possible only to see the set point or the MAX o Min temperature stored
3. If a key is pressed more than 3s the "POF" message will be displayed.

6.7 TO UNLOCK THE KEYBOARD

Keep pressed together for more than 3s the ▲ and ▼ keys, till the "Pon" message will be displayed.

6.8 THE CONTINUOUS CYCLE

When defrost is not in progress, it can be activated by holding the "o" key pressed for about 3 seconds. The compressor operates to maintain the "ccS" set point for the time set through the "CCt" parameter. The cycle can be terminated before the end of the set time using the same activation key "o" for 3 seconds.

6.9 THE ON/OFF FUNCTION

With "onF = oFF", pushing the **ON/OFF** key, the instrument is switched off.

-  The "oFF" message is displayed. In this configuration, the regulation is disabled.
To switch the instrument on, push again the **ON/OFF** key.

WARNING: Loads connected to the normally closed contacts of the relays are always supplied and under voltage, even if the instrument is in stand by mode.

7. PARAMETERS

REGULATION

Hy Differential: (0,1 ÷ 25,5°C / 1÷255 °F) Intervention differential for set point. Compressor Cut IN is Set Point + differential (Hy). Compressor Cut OUT is when the temperature reaches the set point.

LS Minimum set point: (- 50°C÷SET/-58°F÷SET): Sets the minimum value for the set point.

US Maximum set point: (SET÷110°C/ SET÷230°F). Set the maximum value for set point.

Ot Thermostat probe calibration: (-12.0÷12.0°C; -120÷120°F) allows to adjust possible offset of the thermostat probe.

P3P Third probe presence (P3): n= not present, the terminal operates as digital input.; y=present, the terminal operates as third probe.

O3 Third probe calibration (P3): (-12.0÷12.0°C; -120÷120°F). allows to adjust possible offset of the third probe.

P4P Fourth probe presence: (n = Not present; y = present).

o4 Fourth probe calibration: (-12.0÷12.0°C) allows to adjust possible offset of the fourth probe.

Ods Outputs activation delay at start up: (0÷255min) This function is enabled at the initial start up of the instrument and inhibits any output activation for the period of time set in the parameter.

AC Anti-short cycle delay: (0÷50 min) minimum interval between the compressor stop and the following restart.

CCt Compressor ON time during continuous cycle: (0.0÷24.0h; res. 10min) Allows to set the length of the continuous cycle: compressor stays on without interruption for the CCt time. Can be used, for instance, when the room is filled with new products.

CCS Set point for continuous cycle: (-50÷150°C) it sets the set point used during the continuous cycle.

COn Compressor ON time with faulty probe: (0÷255 min) time during which the compressor is active in case of faulty thermostat probe. With COn=0 compressor is always OFF.

COF Compressor OFF time with faulty probe: (0÷255 min) time during which the compressor is OFF in case of faulty thermostat probe. With COF=0 compressor is always active.

CH Type of action: CL = cooling; Ht = heating.

DISPLAY

CF Temperature measurement unit: °C=Celsius; °F=Fahrenheit. **WARNING:** When the measurement unit is changed the SET point and the values of the parameters Hy, LS, US, Ot, ALU and ALL have to be checked and modified if necessary).

rES Resolution (for °C): (in = 1°C; dE = 0.1 °C) allows decimal point display.

dLy Display delay: (0 ÷20.0m; risul. 10s) when the temperature increases, the display is updated of 1 °C/1°F after this time.

DEFROST

IdF Interval between defrost cycles: (0÷120h) Determines the time interval between the beginning of two defrost cycles.

MdF (Maximum) length for defrost: (0÷255min) When **P2P = n**, (not evaporator probe: timed defrost) it sets the defrost duration, when **P2P = y** (defrost end based on temperature) it sets the maximum length for defrost.

dFd Temperature displayed during defrost: (rt = real temperature; it = temperature at defrost start; SET = set point; dEF = "dEF" label)

dAd MAX display delay after defrost: (0÷255min). Sets the maximum time between the end of defrost and the restarting of the real room temperature display.

ALARMS

ALC Temperature alarms configuration: (Ab; rE)

Ab= absolute temperature: alarm temperature is given by the ALL or ALU values. rE = temperature alarms are referred to the set point. Temperature alarm is enabled when the temperature exceeds the "SET+ALU" or "SET-ALL" values.

ALU MAXIMUM temperature alarm: (SET÷110°C; SET÷230°F) when this temperature is reached the alarm is enabled, after the "ALd" delay time.

ALL Minimum temperature alarm: (-50.0 ÷ SET°C; -58÷230°F) when this temperature is reached the alarm is enabled, after the "ALd" delay time.

AFH Differential for temperature alarm recovery: (0,1÷25,5°C; 1÷45°F) Intervention differential for recovery of temperature alarm.

ALd Temperature alarm delay: (0÷255 min) time interval between the detection of an alarm condition and alarm signalling.

dAO Exclusion of temperature alarm at startup: (from 0.0 min to 23.5h) time interval between the detection of the temperature alarm condition after instrument power on and alarm signalling.

CONDENSER TEMPERATURE ALARM (detected by the fourth probe)

AP2 Probe selection for temperature alarm of condenser: nP = no probe;

P1 = thermostat probe; P2 = evaporator probe; P3 = configurable probe; P4 = Probe on Hot Key plug.

AL2 Low temperature alarm of condenser: (-55÷150°C) when this temperature is reached the LA2 alarm is signalled, possibly after the Ad2 delay.

Au2 High temperature alarm of condenser: (-55÷150°C) when this temperature is reached the HA2 alarm is signalled, possibly after the Ad2 delay.

AH2 Differential for temperature condenser alarm recovery: (0,1÷25,5°C; 1÷45°F)

Ad2 Condenser temperature alarm delay: (0÷255 min) time interval between the detection of the condenser alarm condition and alarm signalling.

da2 Condenser temperature alarm exclusion at start up: (from 0.0 min to 23.5h, res.10min)

bLL Compressor off with low temperature alarm of condenser: n = no: compressor keeps on working; Y = yes, compressor is switched off till the alarm is present, in any case regulation restarts after AC time at minimum.

AC2 Compressor off with high temperature alarm of condenser: n = no: compressor keeps on working; Y = yes, compressor is switched off till the alarm is present, in any case regulation restarts after AC time at minimum.

SECOND RELAY

tbA Alarm relay silencing (with oA1=ALr):

(n= silencing disabled: alarm relay stays on till alarm condition lasts,

y= silencing enabled: alarm relay is switched OFF by pressing a key during an alarm).

oA1 Second relay configuration: ALr: alarm; Lig: light; AuS: Auxiliary relay;

onF: always on with instrument on; db = do not select it; dEF: do not select it!; FAn: do not select it!; dF2: do not select it.

AoP Alarm relay polarity: it set if the alarm relay is open or closed when an alarm happens. CL= terminals 1-2 closed during an alarm; oP = terminals 1-2 open during an alarm

DIGITAL INPUT

i1P Digital input polarity: oP: the digital input is activated by opening the contact; CL: the digital input is activated by closing the contact.

i1F Digital input configuration: EAL = external alarm: "EA" message is displayed; bAL = serious alarm "CA" message is displayed. PAL

pressure switch alarm, "CA" message is displayed; dor = door switch function; dEF = activation of a defrost cycle; AUS = to switch on the second relay if oA1 = Htr = kind of action inversion (cooling – heating); FAn = not set it;

did: (0÷255 min) with i1F = EAL or i1F = bAL digital input alarm delay: delay between the detection of the external alarm condition and its signalling.

with i1F= dor: door open signalling delay

with i1F = PAL: time for pressure switch function: time interval to calculate the number of the pressure switch activation.

nPS Pressure switch number: (0 ÷15) Number of activation of the pressure switch, during the "did" interval before signaling the alarm event.(12F = PAL)

If the nPS activation in the did time is reached, switch off and on the instrument to restart normal regulation.

odc Compressor status with door open: no, Fan = normal; CPr;

F_C = Compressor OFF.

rrd Outputs restart after doA alarm: no = outputs not affected by the doA alarm;

yES = outputs restart with the doA alarm;

HES Temperature increase during the Energy Saving cycle it sets the increasing value of the set point during the Energy Saving cycle

OTHER

Adr Serial address (1÷244): Identifies the instrument address when connected to a ModBUS compatible monitoring system.

PbC Type of probe: it allows to set the kind of probe used by the instrument: PbC = PBC probe, ntc = NTC probe.

onF on/off key enabling: nu = disabled; oFF = enabled; ES = not set it.

dP1 Thermostat probe display

dP3 Third probe display- optional.

dP4 Fourth probe display.

rSE Real set point: (readable only), it shows the set point used during the energy saving cycle or during the continuous cycle.

rEL Software release for internal use.

Ptb Parameter table code: readable only.

8. DIGITAL INPUT (ENABLED WITH P3P = N)

The free voltage digital input is programmable in different configurations by the "i1F" parameter.

8.1 DOOR SWITCH INPUT (i1F = dor)

It signals the door status and the corresponding relay output status through the "odc" parameter: no, Fan = normal (any change); CP, F_C = Compressor OFF.

Since the door is opened, after the delay time set through parameter "did", the door alarm is enabled, the display shows the message "dA" and the regulation restarts is rtr = yES. The alarm stops as soon as the external digital input is disabled again. With the door open, the high and low temperature alarms are disabled.

8.2 GENERIC ALARM (i1F = EAL)

As soon as the digital input is activated the unit will wait for "did" time delay before signaling the "EAL" alarm message. The outputs status don't change. The alarm stops just after the digital input is de-activated.

8.3 SERIOUS ALARM MODE (i1F = bAL)

When the digital input is activated, the unit will wait for "did" time delay before signaling the "CA" alarm message. The relay outputs are switched OFF. The alarm will stop as soon as the digital input is de-activated.

8.4 PRESSURE SWITCH (i1F = PAL)

If during the interval time set by "did" parameter, the pressure switch has reached the number of activation of the "nPS" parameter, the "CA" pressure alarm message will be displayed. The compressor and the regulation are stopped. When the digital input is ON the compressor is always OFF.

If the nPS activation in the did time is reached, switch off and on the instrument to restart normal regulation.

8.5 START DEFROST (i1F = dFr)

It starts a defrost if there are the right conditions. After the defrost is finished, the normal regulation will restart only if the digital input is disabled otherwise the instrument will wait until the "Mdf" safety time is expired.

8.6 INVERSION OF THE KIND OF ACTION: HEATING-COOLING (i1F = Htr)

This function allows to invert the regulation of the controller: from cooling to heating and viceversa.

8.7 ENERGY SAVING (i1F = ES)

The Energy Saving function allows to change the set point value as the result of the SET+HES (parameter) sum. This function is enabled until the digital input is activated.

8.8 DIGITAL INPUTS POLARITY

The digital input polarity depends on the "i1P" parameter.

i1P=CL: the input is activated by closing the contact.

i1P=OP: the input is activated by opening the contact

9. TTL SERIAL LINE FOR MONITORING SYSTEMS

The TTL serial line, available through the HOT KEY connector, allows by means of the external TTL/RS485 converter, XJ485-CX, to connect the instrument to a monitoring system ModBUS-RTU compatible such as the X-WEB500/3000/300.

10. X-REP OUTPUT OPTIONAL

As optional, an X-REP can be connected to the instrument, through the HOT KEY connector. The X-REP output EXCLUDES the serial connection.



To connect the X-REP to the instrument the following connectors must be used CAB-51F(1m) CAB-52F(2m), CAB- 55F(5m)

11. INSTALLATION AND MOUNTING

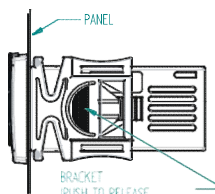

Instrument XR30CH shall be mounted on vertical panel, in a 29x71 mm hole, and fixed using the special bracket supplied. The temperature range allowed for correct operation is 0÷60 °C. Avoid places subject to strong vibrations, corrosive gases, excessive dirt or humidity. The same recommendations apply to probes. Let air circulate by the cooling holes.

12. ELECTRICAL CONNECTIONS

The instrument is provided with screw terminal block to connect cables with a cross section up to 2,5 mm². Before connecting cables make sure the power supply complies with the instrument's requirements. Separate the probe cables from the power supply cables, from the outputs and the power connections. Do not exceed the maximum current allowed on each relay, in case of heavier loads use a suitable external relay.

12.1 PROBE CONNECTION

The probes shall be mounted with the bulb upwards to prevent damages due to casual liquid infiltration. It is recommended to place the thermostat probe away from air streams to correctly measure the average room temperature. Place the defrost termination probe among the evaporator fins in the coldest place, where most ice is formed, far from heaters or from the warmest place during defrost, to prevent premature defrost termination.

13. HOW TO USE THE HOT KEY

13.1 HOW TO PROGRAM A HOT KEY FROM THE INSTRUMENT (UPLOAD)

1. Program one controller with the front keypad.
2. When the controller is **ON**, insert the "Hot key" and push **▲** key, the "uPL" message appears followed a by flashing "End"
3. Push "SET" key and the End will stop flashing.
4. Turn **OFF** the instrument remove the "Hot Key", then turn it ON again.

NOTE: the "Err" message is displayed for failed programming, in this case push again **▲** key if you want to restart the upload again or remove the "Hot Key" to abort the operation.

13.2 HOW TO PROGRAM AN INSTRUMENT USING A HOT KEY (DOWNLOAD)

1. Turn OFF the instrument.
2. Insert a **programmed "Hot Key"** into the 5 PIN receptacle and then turn the Controller ON
3. Automatically the parameter list of the "Hot Key" is downloaded into the Controller memory, the "dOL" message is blinking followed a by flashingnd "End".
4. After 10 seconds the instrument will restart working with the new parameters.
5. Remove the "Hot Key".

NOTE the message "Err" is displayed for failed programming, in this case turn the unit off and then on if you want to restart the download again or remove the "Hot key" to abort the operation.

14. ALARM SIGNALS

Message	Cause	Outputs
"P1"	Room probe failure	Compressor output acc.
"P3"	Third probe failure	Outputs unchanged
"P4"	Fourth probe failure	Outputs unchanged
"HA"	Maximum temperature alarm	Outputs unchanged
"LA"	Minimum temperature alarm	Outputs unchanged
"HA2"	Condenser high temperature	It depends on the "Ac2" parameter
"LA2"	Condenser low temperature	It depends on "bLL" parameter
"dA"	Door open	Compressor according to rrd
"EA"	External alarm	Output unchanged
"CA"	Serious external alarm (i1F=bAL)	All outputs OFF
"CA"	Pressure switch alarm (i1F=PAL)	All outputs OFF

14.1 ALARM RECOVERY

Probe alarms "P1", "P3" and "P4" start some seconds after the fault in the related probe; they automatically stop some seconds after the probe restarts normal operation. Check connections before replacing the probe. Temperature alarms "HA", "LA", "HA2", and "LA2" automatically stop as soon as the temperature returns to normal values. Alarms "EA" and "CA" (with I 1F = bAL) recover as soon as the digital input is disabled. Alarm "CA" (with i1F = PAL) recovers only by **switching off and on** the instrument.

14.2 OTHER MESSAGES

Pon	Keyboard unlocked.
PoF	Keyboard locked
noP	In programming mode: none parameter is present in Pr1 On the display or in dP2, dP3, dP4: the selected probe is nor enabled
noA	None alarm is recorded.

15. TECHNICAL DATA

Housing: self-extinguishing ABS.

Case: XR30CH frontal 38 x 80 mm; depth 62 mm.

Mounting: XR30CH panel mounting in a 71 x 29 mm panel cut-out

Protection: IP20; **Frontal protection:** XR30CH IP65

Connections: Screw terminal block $\leq 2,5 \text{ mm}^2$ wiring.

Power supply: according to the model: 12Vac/dc, $\pm 10\%$; 24Vac/dc, $\pm 10\%$; 230 Vac $\pm 10\%$, 50/60 Hz, 110 Vac $\pm 10\%$, 50/60 Hz

Power absorption: 3VA max

Display: 3 digits, red LED, 14,2 mm high; Inputs: Up to 4 NTC or PTC probes.

Digital input: free voltage contact

Relay outputs: compressor SPST 8(3) A, 250Vac; or 20(8) A 250Vac

AUX: SPDT 8(3) A, 250Vac

Data storing: on the non-volatile memory (EEPROM).

Kind of action: 1B; Pollution grade: 2; Software class: A.;

Rated impulsive voltage: 2500V; Overvoltage Category: II

Operating temperature: 0 \pm 60 °C; Storage temperature: -30 \pm 85 °C.

Relative humidity: 20 85% (no condensing)

Measuring and regulation range: NTC probe: -40 \pm 110 °C (-40 \pm 230 °F);

PTC probe: -50 \pm 150 °C (-58 \pm 302 °F)

Resolution: 0,1 °C or 1 °C or 1 °F (selectable);

Accuracy (ambient temp. 25 °C): $\pm 0,7 \text{ °C} \pm 1 \text{ digit}$.

16. CONNECTIONS

The X-REP output excludes the TTL output. It's present in the following codes: XR30CH- xx2xx, XR30CH - xx3xx.

16.1 XR30CH- 8A COMPRESSOR

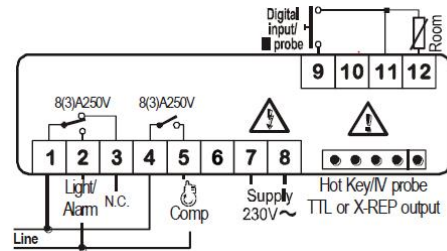

9-40Vdc supply: connect to the terminals 7 and 8.

12Vac/dc supply: connect to the terminals 7 and 8.

24Vac/dc supply: connect to the terminals 7 and 8.

120Vac supply: connect to the terminals 7 and 8.

16.2 XR30CH - 20A COMPRESSOR

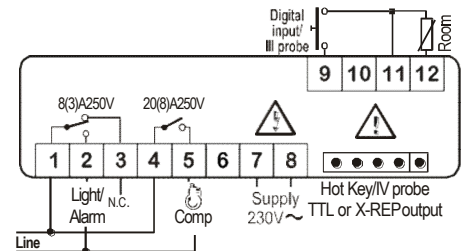

9-40Vdc supply: connect to the terminals 7 and 8.

12Vac/dc supply: connect to the terminals 7 and 8.

24Vac/dc supply: connect to the terminals 7 and 8.

120Vac supply: connect to the terminals 7 and 8.

17. FACTORY SETTINGS DIXELL XR30CH

Lable	Name	Set
Set	Set point	-80
Hy	Differential	3.0
LS	Minimum set point	-85
US	Maximum set point	-50
Ot	Thermostat probe calibration	5.0
OdS	Outputs delay at start up	0
AC	Anti-short cycle delay	5
CCt	Continuos cycle duration	0.0
CCS	Set point for continuous cycle,	0.0
COn	Compressor ON time with faulty probe	1
COF	Compressor OFF time with faulty probe	0
CH	Kind of action	CL
CF	Temperature measurement unit	°C
rES	Resolution	dE
dLy	Display temperature delay	0.0
IdF	Interval between defrost cycles	0
MdF	Maximum length for defrost	0
dFd	Displaying during defrost	rt
dAd	MAX display delay after defrost	0
ALc	Temperat. alarms configuration	rE
ALU	MAXIMUM temperature alarm	10.0
ALL	MINIMUM temperature alarm	5.0
AFH	Differential for temperat. alarm recovery	2.0
ALd	Temperature alarm delay	60
dAo	Delay of temperature alarm at start up	8.0
tbA	Alarm relay disabling	n
AoP	Alarm relay polarity (oA1=ALr)	OP
i1P	Digital input polarity	CL
i1F	Digital input configuration	AUS
did	Digital input alarm delay	0
nPS	Number of activation of pressure switch	0
odc	Compress status when open door	no
rrd	Regulation restart with door open alarm	y
HES	Differential for Energy Saving	0
Adr.	Serial address	1
PbC	Kind of probe	pt1
onF	on/off key enabling	no
rSE	Room probe display	-85
rEL	Software release	1.6
Ptb	Map code	1



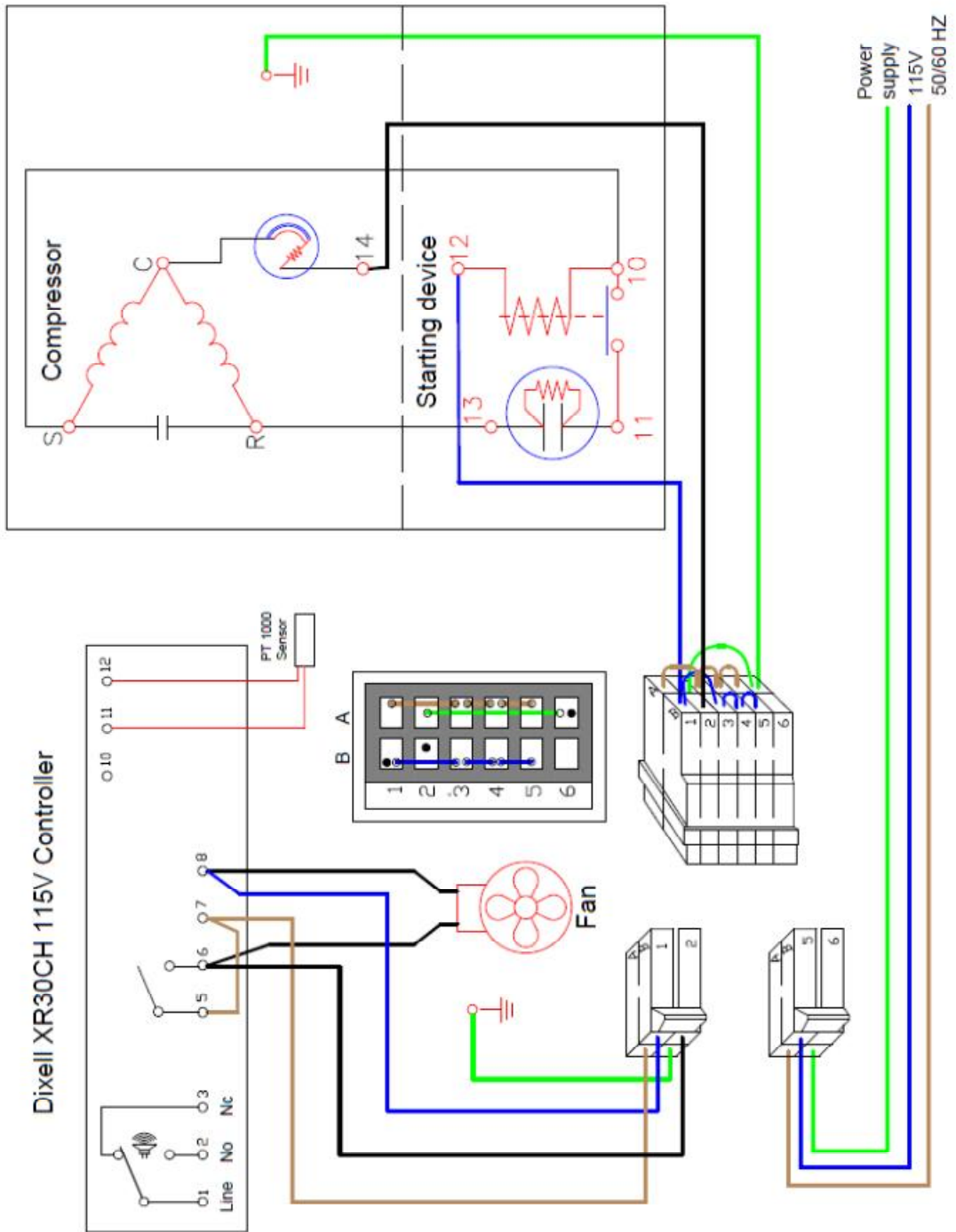

Tegnet af/ Dato	Godkendt af / Dato	File name	Scale Ikke målfast
MP 030417		PDA TED1000	Side 1/1

Wiring diagram for UNI/ PRO/ LAB 41-51-60

Tegnings nr.: TED1001-01

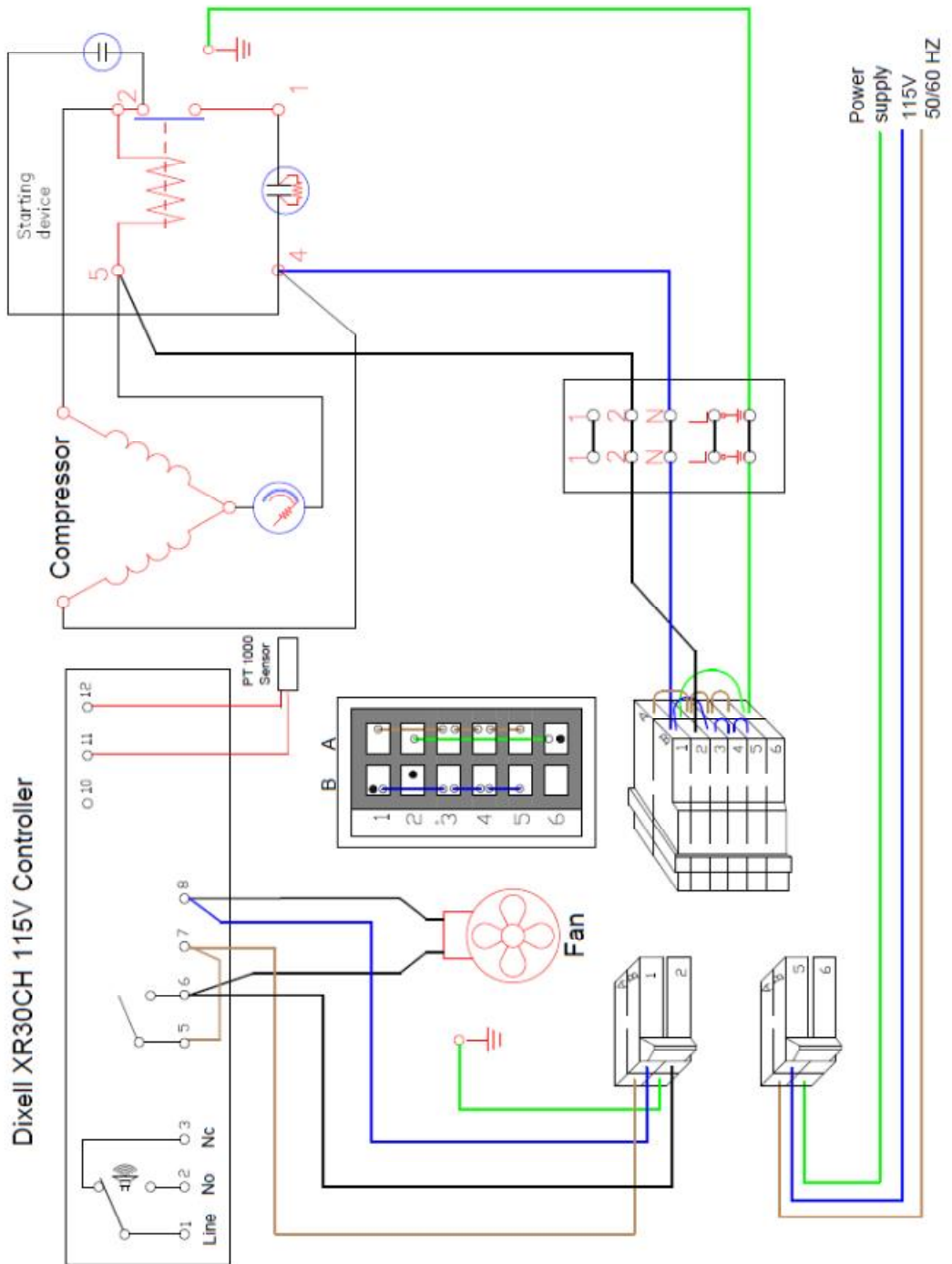

Tegnet af/ Dato	Godkendt af / Dato	File name	Scale Ikke måfast
MP030417		PDA TED1001	Side 1/1

Wiring diagram for UNI/ PRO/ LAB 11-21-31

Tegnings nr.: TED2000-03

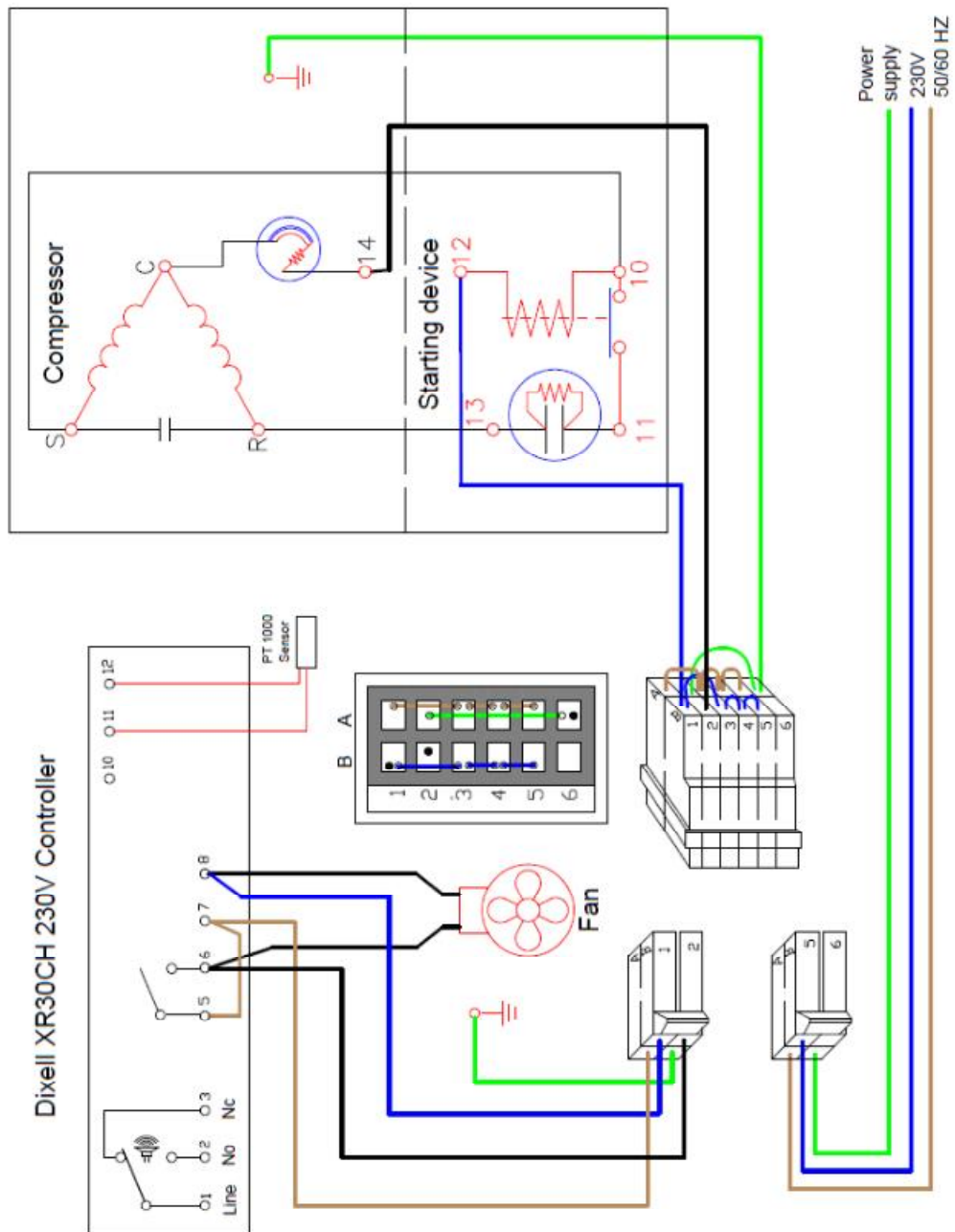

Dixell XR30CH 230V Controller

Tegnet af / Dato	Godkendt af / Dato	File name	Scale Ikke målfast
MP 030417		PDA TED2000	Side 1/1

Wiring diagram for UNI/ PRO/ LAB 41-51-60

Tegnings nr.: TED2001-03

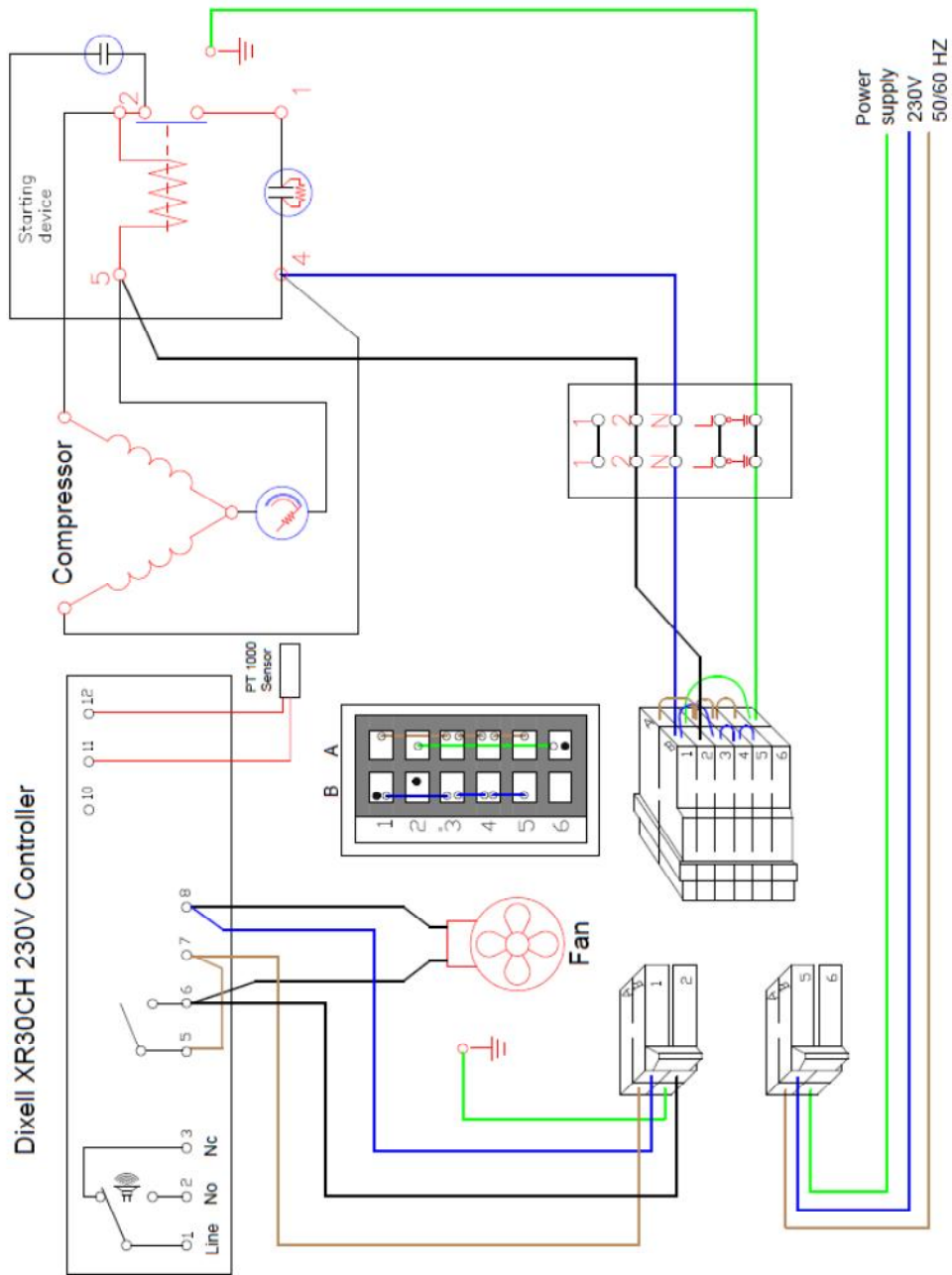

Tegnet af/ Dato	Godkendt af / Dato	File name	Scale Ikke målfast
MP030417		PDA TED2001	Side 1/1