

Heated Drawers

OPERATING MANUAL AND INSTRUCTIONS

CAUTION

INSPECT CONTENTS IMMEDIATELY AND FILE CLAIM WITH DELIVERING CARRIER FOR ANY DAMAGE. **SAVE YOUR BOX AND ALL PACKING MATERIALS.** YOU ARE RESPONSIBLE FOR DAMAGE TO YOUR UNIT IF RETURNED IMPROPERLY PACKED.

Thank you for your purchase. Before assembly, read this manual carefully.

Retain this manual for future reference.

Contact this factory, the factory representative or Eagle's authorized service center in your area to perform maintenance and repairs.

This unit has been manufactured in accordance with Underwriters Laboratories and National Sanitation Foundation standards, consult local electrical and sanitation codes for compliance. Please reference the electrical specifications in this manual to insure that proper amperage and voltage is used for your application. Built-in units must be installed in compliance with the NEC.

UNPACKING INSTRUCTIONS

- To unpack the heated drawer, first remove the four $\frac{3}{8}$ " bolts, using a wrench, that secure the unit to the crate located on the underside of the crating (freestanding units only).
- Carefully remove the crating from the unit so as to not cause damage.
- Remove all plastic wrap from the exterior of the unit.
- Remove any tape or adhesive that may be holding the drawers closed.
- Please remove any warranty or instruction information from the drawers prior to use and store in safe location for future reference.
- Remember to properly sanitize and clean the unit before use.

(continued inside)

EG9986 Revised 03/24



• 100 Industrial Boulevard, Clayton, Delaware 19938-8903 U.S.A.
• Phone: 302/653-3000 • 800/441-8440 • Fax: 302/653-2065
• www.eaglegrp.com • www.eaglehmc.com

Eagle Foodservice Equipment, Eagle MHC, and SpecFAB® are divisions of Eagle Group. ©2024 by the Eagle Group

Parts List

Drawer Warmer
Free Standing
Wide & Narrow Units
120V & 240V

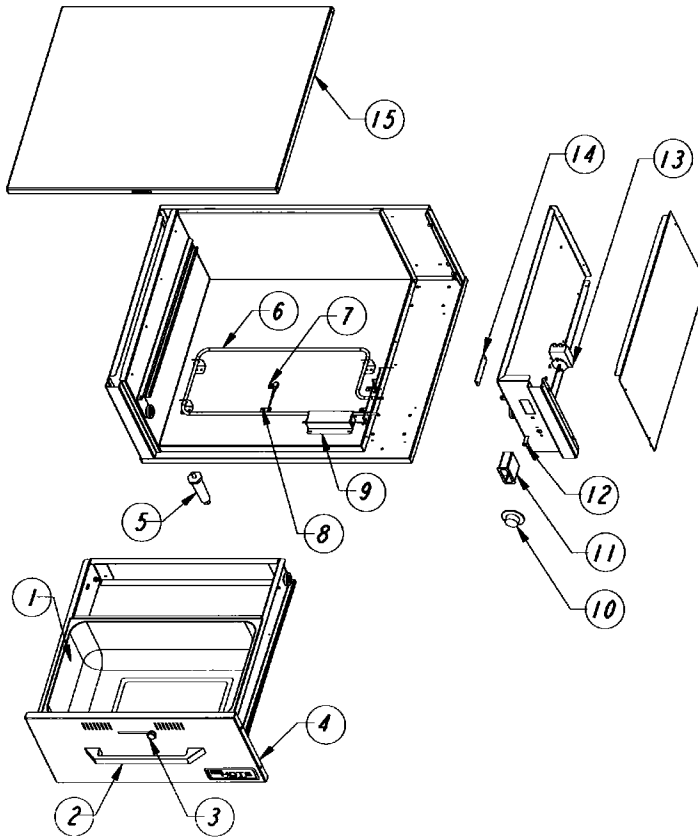

Note: Drawer Assy (#4) includes items #2 & #3.

Item #	Part Description	Part# DWW Units All Sizes	Part# DWN Units All Sizes
1	12x20 Pan	331160	331160
2	Drawer Handle	331221	331221
3	Knob	331218	331218
4	Drawer Assy	339072	339147
5	Leg/Foot	301556	301556
6	Heater Element	See Note (*)	See Note (*)
7	Wire Clamp 5/16"	339314	339314
8	Wire Clamp 1/8"	339311	339314
9	Capillary Housing	338404	338404
10	Control Knob	301986	301986
11	Thermometer	331214	331214
12	Indicator Light	338132	338132
13	Thermostat	331153	331153
14	Wire Cover Plate	339128	339128
15	Top Panel	339017	339018

- * Element 339167, 120V (DWW-X-120), use (307226) Cord & Plug.
- * Element 339168, 240V (DWW-X-240), use (301780) Cord & Plug.
- * Element 339166, 120V (DWN-X-120), use (307226) Cord & Plug.
- * Element 339169, 240V (DWN-X-240), use (301780) Cord * Plug.

Parts List

Drawer Warmer Built-In Wide & Narrow Units 120V & 240V

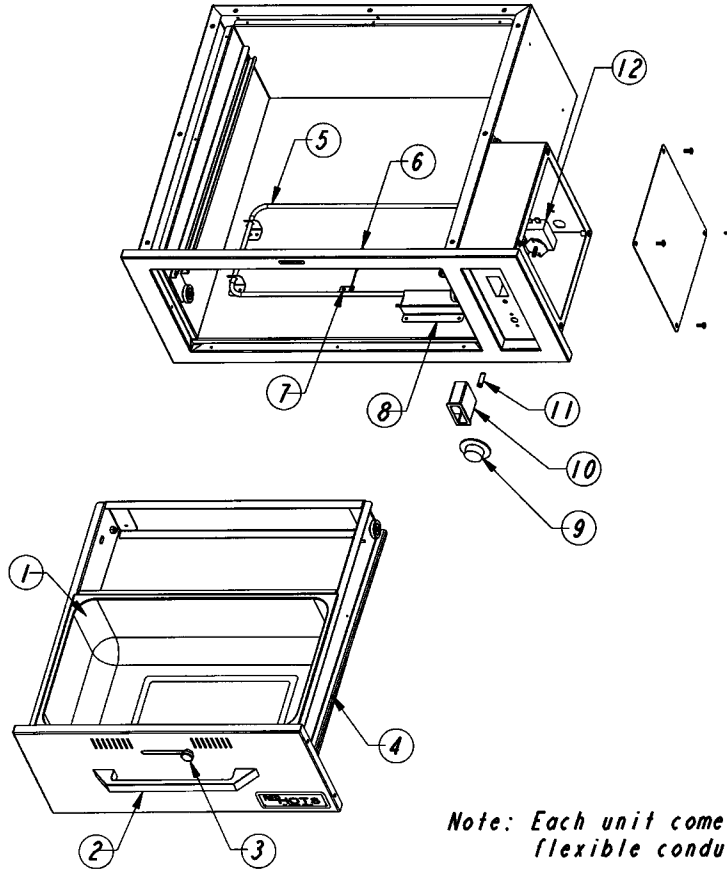

Note: Each unit come complete with steel flexible conduit for wiring.

Note: Drawer Assy (#4) includes items #2 & #3.
Item #13 Not Shown

Item #	Part Description	Part# DWW-XBI Units All Sizes	Part# DWN-XBI Units All Sizes
1	12x20 Pan	331160	331160
2	Drawer Handle	331221	331221
3	Knob	331218	331218
4	Drawer Assy	339262	339238
5	Heater Element	See Note (*)	See Note (*)
6	Wire Clamp 5/16"	339314	339314
7	Wire Clamp 1/8"	339311	339311
8	Capillary Housing	338404	338404
9	Control Knob	301986	301986
10	Thermometer	331214	331214
11	Indicator Light	338132	338132
12	Thermostat	331153	331153
13	Wire Cover Plate	339128	339128

* Element 339167, 120V (DWW-XBI-120),
* Element 339168, 240V (DWW-XBI-240),
* Element 339166, 120V (DWN-XBI-120),
* Element 339169, 240V (DWN-XBI-240),

INSTALLATION INSTRUCTIONS

Freestanding Units

- 1 Legs**
Install the legs into the bottom of the unit by threading them into the nut inserts and tightening securely.
- 2 Outlet**
Locate the unit in a desired area within reach of an appropriately sized electrical outlet. Consult electrical chart.
- 3 Level**
Place unit on a flat, even surface and check that the unit is level both left-to-right and front-to-back. Adjust feet as needed for a level installation.

CAUTION!

LEGS MUST BE INSTALLED PRIOR TO THE OPERATION OF THE UNIT. TO AVOID DAMAGE, DO NOT LAY UNIT ON ITS FRONT OR BACK SIDE.

Built-In Units

- 1 Tape**
Remove any tape that may be holding the conduit to the unit before installing.
- 2 Location**
Please read the information provided under Location before determining installation site.
 - a** Locate the unit in an area that is convenient for use. The location should be level to prevent the unit or its contents from accidentally falling, and strong enough to support the weight of the unit and its contents.
 - b** For safe and proper operation, the unit must be located a reasonable distance from combustible walls and materials. If safe distances are not maintained discoloration or combustion could occur.
- 3 Level**
Determine cutout sizes for your unit using the chart located below.

Cutout Sizes for Built-In Drawer Warmers

<i>Model</i>	<i>Height</i>	<i>Width</i>	<i>Depth</i>
DWW-1BI-120 or 240	10 $\frac{1}{2}$ "	29 $\frac{3}{4}$ "	23 $\frac{3}{4}$ "
DWW-2BI-120 or 240	21 $\frac{1}{4}$ "	29 $\frac{3}{4}$ "	23 $\frac{3}{4}$ "
DWW-3BI-120 or 240	32 $\frac{1}{2}$ "	29 $\frac{3}{4}$ "	23 $\frac{3}{4}$ "
DWN-1BI-120 or 240	10 $\frac{1}{2}$ "	21 $\frac{1}{4}$ "	26 $\frac{1}{2}$ "
DWN-2BI-120 or 240	21 $\frac{1}{4}$ "	21 $\frac{1}{4}$ "	26 $\frac{1}{2}$ "
DWN-3BI-120 or 240	32 $\frac{1}{2}$ "	21 $\frac{1}{4}$ "	26 $\frac{1}{2}$ "

- 4 Locking Strip**
When the proper cutout has been made, a locking strip (not supplied by Eagle) must be permanently fixed to the lower front side of the cabinet opening.
Note: Maintain a minimum clearance of 1" from the bottom of the cutout to floor.
- 5 Installing**
Once the unit is installed into the opening, apply a bead of NSF-approved sealant around the drawer cabinet flanges and the location.
- 6 Connections**
Final connections must be made in accordance with a NEC listed junction box.

Plug Configurations

Freestanding Units

All freestanding units are factory supplied with a cord and plug. Please check to make sure that the plug matches the receptacle.

- 1) 120V units supplied with a NEMA 5-15P plug configurations.
- 2) 240V units supplied with a NEMA 6-15P plug configurations.

CAUTION!

FOR FREESTANDING UNITS, PLUG UNIT ONLY INTO A RECEPTACLE OF COMPATIBLE VOLTAGE AND PLUG CONFIGURATION. IF THE APPROPRIATE RECEPTACLE IS NOT AVAILABLE, CONTACT A CERTIFIED ELECTRICIAN TO INSTALL THE CORRECT OUTLET. SEE "ELECTRICAL RATING CHART" BELOW.

Built-In Units

All built-in units are supplied with factory installed flexible steel conduit and applicable wiring.

Electrical Rating Chart

<i>Model</i>	<i>Watts</i>	<i>Amps</i>	<i>Plug</i>	<i>Length</i>	<i>Depth</i>	<i>Height</i>
DWW-1-120	450	3.8	NEMA 5-15P	29"	23¼"	16¼"
DWW-1-240	450	1.9	NEMA 6-15P	29"	23¼"	16¼"
DWW-2-120	900	7.5	NEMA 5-15P	29"	23¼"	26⅝"
DWW-2-240	900	3.8	NEMA 6-15P	29"	23¼"	26⅝"
DWW-3-120	1350	11.3	NEMA 5-15P	29"	23¼"	37"
DWW-3-240	1350	5.6	NEMA 6-15P	29"	23¼"	37"
DWN-1-120	450	3.8	NEMA 5-15P	21"	27¾"	16¼"
DWN-1-240	450	1.9	NEMA 6-15P	21"	27¾"	16¼"
DWN-2-120	900	7.5	NEMA 5-15P	21"	27¾"	26⅝"
DWN-2-240	900	3.8	NEMA 6-15P	21"	27¾"	26⅝"
DWN-3-120	1350	11.3	NEMA 5-15P	21"	27¾"	37"
DWN-3-240	1350	5.6	NEMA 6-15P	21"	27¾"	37"
DWW-1BI-120	450	3.8	Conduit	31"	23¼"	12¼"
DWW-1BI-240	450	1.9	Conduit	31"	23¼"	12¼"
DWW-2BI-120	900	7.5	Conduit	31"	23¼"	23⅝"
DWW-2BI-240	900	3.8	Conduit	31"	23¼"	23⅝"
DWW-3BI-120	1350	11.3	Conduit	31"	23¼"	34"
DWW-3BI-240	1350	5.6	Conduit	31"	23¼"	34"
DWN-1BI-120	450	3.8	Conduit	23"	26¾"	12¼"
DWN-1BI-240	450	1.9	Conduit	23"	26¾"	12¼"
DWN-2BI-120	900	7.5	Conduit	23"	26¾"	23⅝"
DWN-2BI-240	900	3.8	Conduit	23"	26¾"	23⅝"
DWN-3BI-120	1350	11.3	Conduit	23"	26¾"	34"
DWN-3BI-240	1350	5.6	Conduit	23"	26¾"	34"

OPERATING INSTRUCTIONS

1 Plug

On freestanding models, plug unit into an electrical outlet of the correct voltage, size and plug configuration.

2 Power

To turn the power on, turn the thermostat control to the desired temperature. See “Food Holding Guide” below for recommended settings.

3 Pre-heat

Allow the unit 15-20 minutes to reach operating temperature. Moist applications may require additional preheat time.

4 Vents

Referring to “Food Holding Guide” below, adjust the drawer vents for desired humidity by loosening front drawer knob to unlock the vent and slide the vent to desired location. Opening the vent all the way allows maximum moisture to escape.

Food Holding Guide

<i>Product</i>	<i>Rec. Storage Temp.</i>	<i>Heat Type</i>	<i>Vent Control</i>	<i>Capacity</i>
Rolls, Hard	160-185°F (71-85°C)	Dry	closed	6-8 dz
Rolls, Soft	150-175°F (66-79°C)	Moist	open-half	6-8 dz
Vegetables	175-185°F (66-85°C)	Moist	open-half	3-3½ dz potatoes
Meat, Poultry	165-185°F (74-85°C)	Dry	closed	25-30 lbs. ribs
Fish	165-185°F (74-85°C)	Moist	open	
Casseroles	150-175°F (66-79°C)	Dry	closed	
Pies, Desserts	160-185°F (71-85°C)	Dry	closed	

Care and Maintenance

To avoid injury, turn the power off and allow unit to cool before cleaning or performing maintenance. On freestanding units, unplug the electrical cord and/or turn off circuit breaker.

To preserve the finish of the drawer warmer, it is recommended that the surface be wiped daily with a damp cloth. Food pans should be removed and washed. Stubborn stains may be removed with a non-abrasive cleaner. Hard to reach areas should be cleaned with a small brush and mild soap.

CAUTION!

Abrasive cleaners could scratch the finish of the drawer warmer.

Removing Lime and Mineral Deposits

Note: If the water used has an excessive amount of lime or mineral content, use the following instructions for periodic cleaning and de-liming of the water pan.

1. Turn off the power. On freestanding units, unplug the cord from the power source.
2. After the unit has cooled down, remove the water pan.
3. Fill the water pan with a mixture of water and de-limer. Allow the pan to stand with the mixture for the recommended period of time. The time required will depend on the solution used and the amount of deposits in the pan. Check de-limer manufacturer for specific directions.
4. After the de-liming period, drain the solution from the pan.
5. Continue to fill and rinse the pan with water only, until the pan becomes clean.
6. Install the pan into the unit. On freestanding units, plug the power cord into the receptacle and fill the pan as usual.

Wiring Diagram

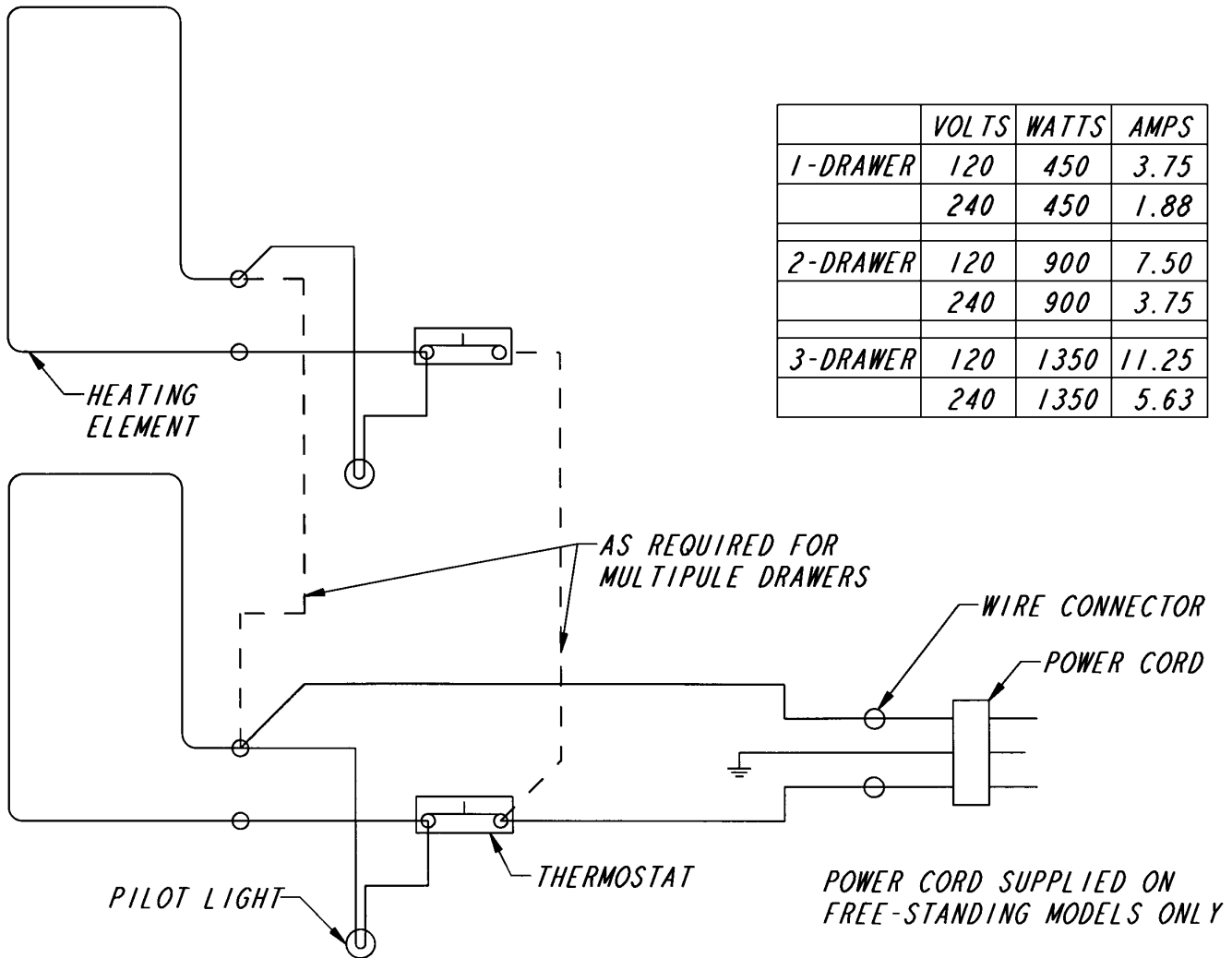

	VOLTS	WATTS	AMPS
1-DRAWER	120	450	3.75
	240	450	1.88
2-DRAWER	120	900	7.50
	240	900	3.75
3-DRAWER	120	1350	11.25
	240	1350	5.63

