

# ADCRAFT®



**ADC2BFG**

Double, 6 gal.



**ADC3BFG**

Triple, 6 gal.

## Granita Instruction Manual

This manual contains important information regarding your Adcraft unit. Please read this manual thoroughly prior to equipment set-up, operation, and maintenance. Failure to comply with regular maintenance guidelines outlined in this manual may void the warranty.



## IMPORTANT SAFEGUARDS

- Please read all the instructions to familiarize yourself with all the parts and operations before use.
- **DO NOT** leave the appliance unattended during use.
- Children shall **NOT** play with the appliance.
  - \* This appliance shall **NOT BE** used by children.
  - \* Keep the appliance and its cord out of reach of children.
- The unit is not intended for use by persons with reduced physical sensory or mental capabilities, or lack of experience and knowledge unless they have been given supervision or instruction concerning the use of the appliance by a person responsible for their safety.
- **ONLY QUALIFIED PERSONS SHOULD:**
  - \* Repair or break into the refrigerating circuit.
  - \* Open and repair the sealed components.
  - \* Open the ventilated enclosures.
- **ALWAYS** disconnect the power supply:
  - \* **BEFORE** assembling.
  - \* **BEFORE** disassembling.
  - \* **BEFORE** cleaning.
  - \* When not in use and if unit is left unattended
- **DO NOT** operate the unit with a damaged electrical cord or plug. If the supply cord is damaged, it must be replaced by the manufacturer, its service agent or similarly qualified persons in order to avoid a hazard.
- **DO NOT** install the appliance in a place where it may come in contact with water. This may impair electricity insulation and cause electric shock or fire.
- **NEVER** expose electrical connectors to any liquids.
- To avoid any electric shock, never plunge the appliance, the cord or plug in water or other liquid.
- Always install the appliance on a firm and flat worktable.
- Protect the appliance from direct light and heat. **DO NOT** install this appliance outdoors.
- Be sure the appliance is installed in an area where the temperature will not go below 50°F (10°C) or exceed 95°F (35°C).
- **DO NOT** splash or spray water on the surface of appliance while cleaning the machine.
- The appliance is equipped with a temperature controller inside.
  - \* Every unit is preset at the factory for the recommend temperature between 35.6°F (2°C) to 44.6°F (7°C) for chilled drinks.
  - \* **DO NOT** change the preset without a professional technician's advice.

MODEL:	ADC2BFG	ADC3BFG
VOLTAGE:	120V	120V
HERTZ:	60Hz	60Hz
WATTAGE:	1200W	1920W
DIMENSIONS: (HxWxD)	33.27" x 16.77" x 19.29"	33.27" x 24.65" x 19.45"
	845 mm x 426 mm X 490 mm	845 mm x 626 mm X 494 mm
UNIT WEIGHT:	108.03 lbs.	148.81 lbs.
PLUG:	NEMA 5-15P	NEMA 5-20P



## INSTRUCTIONS FOR MACHINE TRANSPORT

- NOTE: Refrigeration equipment must remain upright to avoid damage to the compressor.
- In order to prevent the oil contained in the compressor from flowing into the cooling circuit, it is necessary to always ship, carry, store and handle this machine in an upright position, following the instructions located on the packaging.
- Never ship, carry, store or handle unit on its side.

## PROPER GROUNDING REQUIRED:

**⚠ WARNING:** THIS UNIT MUST BE PROPERLY ELECTRICALLY GROUNDED TO AVOID POSSIBLE FATAL ELECTRICAL SHOCK OR SERIOUS INJURY TO THE OPERATOR. THE POWER CORD IS PROVIDED WITH A THREE PRONG GROUNDED PLUG. IF A THREE-HOLE GROUNDED ELECTRICAL OUTLET IS NOT AVAILABLE, USE AN APPROVED METHOD TO GROUND THE UNIT.

- **DO NOT** USE EXTENSION CORDS WITH THIS UNIT.
- **DO NOT** "GANG" TOGETHER WITH OTHER ELECTRICAL DEVICES ON THE SAME OUTLET.

## CONNECTION TO MAIN POWER SUPPLY

- The electrical safety of this machine can only be achieved if the machine is properly connected to an appropriate grounded receptacle that is in compliance with current national safety standards. Therefore, the manufacturer cannot be held responsible for damage and/or injury caused by failure to connect the unit to an appropriate power source.
- For a safe and correct installation, connect the unit to a dedicated outlet.
- **DO NOT** alter the cord or plug in any way.
- The entire length of the power cord must not, in any way, be compressed, bent or bunched together, nor may extension cords be used.
- **DO NOT** obstruct the ventilation and heat dispersion grill vents on the side and rear panels of the unit. An insufficient ventilation process may reduce the efficiency of the machine, causing it to function inadequately, and cause serious damage to the machine.
  - \* A minimum of eight inches (20cm) clearance is necessary on each side and behind the unit.

## INSTALLATION:

1. Cut banding straps from box and lift the box off the machine (see Fig. A).
2. Position the machine on a on a firm and flat worktable.
3. The machine must be well ventilated.
  - \* Leave an 8" (20 cm) clearance on the sides and back of the machine to allow proper ventilation.
  - \* Installation of the machine near a heat source should be avoided.
  - \* Some heat sources you should avoid locating this unit too close to are ovens, coffee machines, cold or frozen beverage dispensers or ice machines (equipment with compressors that expel hot air through its vents).
  - \* An ambient temperature between 59°F (15°C) and 77°F (25°C) is recommended.

**Figure A**

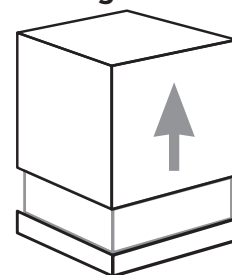

## PARTS DIAGRAM

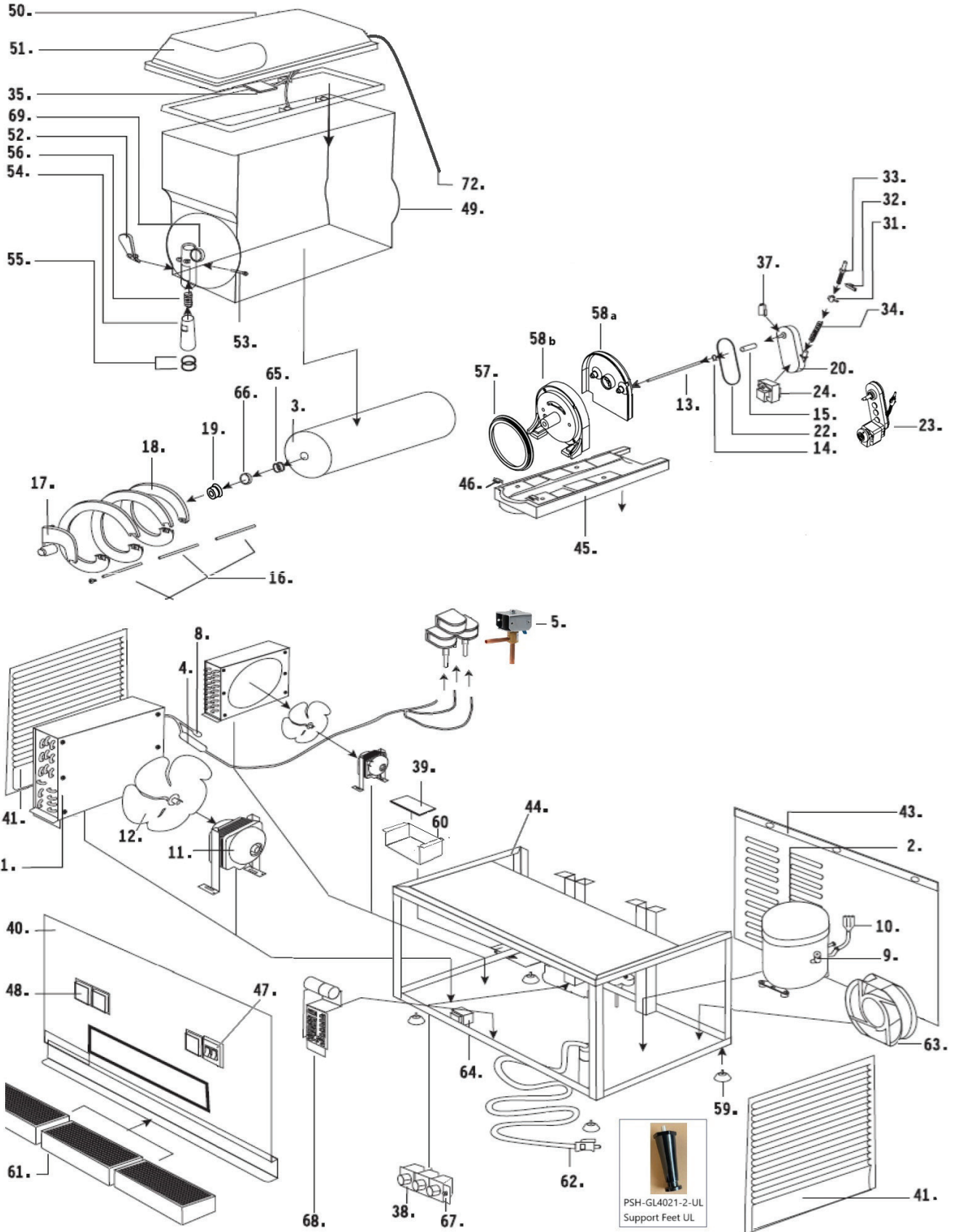

## PARTS LIST

NO.	DESCRIPTION	NO.	DESCRIPTION	NO.	DESCRIPTION
1	Condenser (3"x11" or 3"x8")	24	Coil	53	Pin (Tap)
2	Compressor	31	Bushing for Hardness Control Pin	54	Piston
3	Evaporator	32	Hardness Control Catch	55	O-Ring
4	Filter Dryer	33	Hardness Control Screw	56	Spring
5	Coil/Valve Set	34	Twisted Spring	57	Seal (Bowl)
8	Air Pressure Valve	35	LED Set	58a	Fixed Evaporator Set & Cap
9	Air Pressure Valve	37	Micro Switch	58b	Fixed Evaporator Cover
10	Fitting	38	Temperature Control Switch	59	Support Feet
11	Fan Motor (10" or 8")	39	PC-Board	60a	Cover for PC Board
12	Fan Blades (10" or 8")	40	Front Metal Panel	60b	Stainless Steel Cover for PC Board
13	Drive Spindle for Spiral	41	Side Panel-Left	61	Drip Tray
14	C Ferrule	43	Back Metal Panel	62	Power Cord
15	Brass Bushing	44	Frame	63	Subsidiary Fan Motor
16	Drive Spindle for Spiral	45	Plastic Holder	64	Transformer
17	Scraper for Spiral	46	Pin	65	Gasket
18	Spiral Section	47	Power Switch	66	Bushing
19	Clip for Attaching Scraper	48	Motor Select Switch	67	Protective Switch
20	Gear Box (thick part)	49	PC Bowl	68	Terminals Connectors Set
21	Box Cap (thin part)	50	PC Bowl Cap	69	Positioning Ring
22	Seal	51	Artwork Plate	70	Power Cord
23	Stirring Motor + Coil	52	Handle (Tap)		

## OPERATION AND CONTROLS

**LEFT**

Stir / Cold

Freeze

**MIDDLE**

Stir / Cold

Freeze

**RIGHT**

Stir / Cold

Freeze

**POWER**

Light ON

Light OFF

OFF

- Left - Right - Middle - Bowl Switches
- Each switch corresponds to the number and location of the bowls configuration to the dispenser.
- When the switch is in the UP/ON position the motor and cooling will be turned on.

## FILLING THE BOWLS/TANKS

- **ATTENTION:** Make sure that the mixture has a 13% - 15% minimum Brix (sugar content). A lower concentration could seriously damage the mixing parts, as well as the gear motors.
- **NEVER USE ONLY WATER.**

1. If using product concentrate (instead of ready-to-use product), dilute and mix the product with water, according to the directions given by the manufacturer, in a separate container.
  - \* **NEVER** pour dry powder, crystals, or concentrate into a dry bowl.

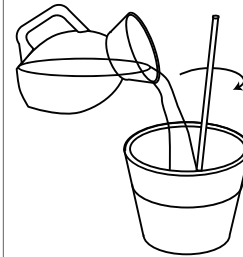

2. Remove the lid.
3. Pour the prepared product into the bowl.
  - \* Do not spill any material on lid or on bowl.
  - \* There is a minimum and maximum fill line on the bowl.
  - \* Do not overfill or run the unit without enough product.
  - \* Running unit with product below the minimum full line may cause damage to the unit.
4. Insert the plug into a dedicated electrical outlet.

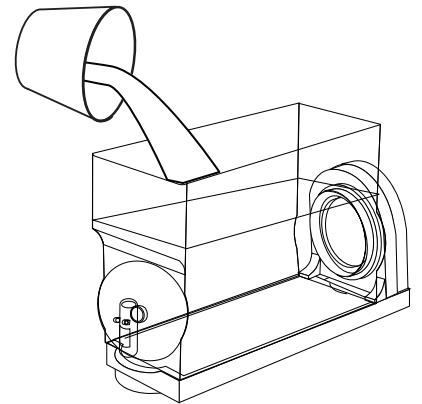

## DISPENSING PRODUCT



### To dispense the product:

1. Position the cup under the dispensing valve.
2. Push the dispensing lever down.

- **NOTE:** If the machine is turned off at night, with the bowls filled, or just partially filled, a layer of solid ice may form on the surface due to the natural separation of the unmixed (non-moving) product. In this case, before turning the machine back on, remove the layer of superficial ice to prevent damage to the spiral agitator.

## CONSISTENCY ADJUSTMENT:

1. Unplug the machine.
2. Be sure that product in the bowl is within proper fill range.
  - \* Above the minimum fill line.
3. Remove merchandiser.

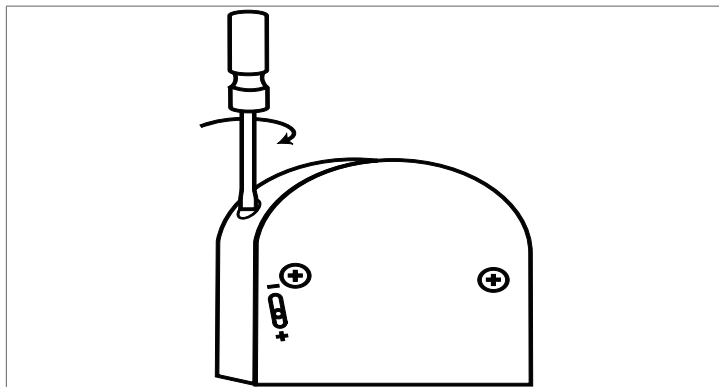

4. Change the thickness of the product by turning the screw on the back of the bowl.

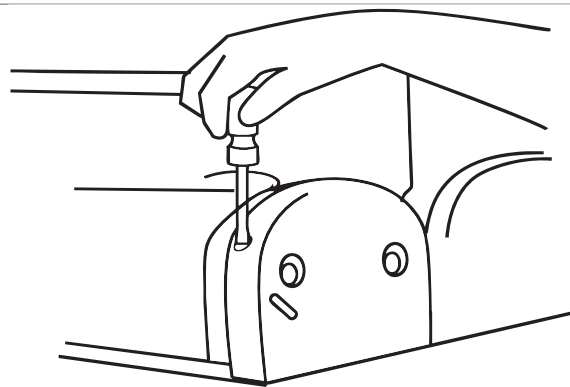

5. Turn the screw clockwise for thinner product or counterclockwise for thicker product, (+) thicker, (-) thinner.

\* Each bowl has its own adjusting screw.

## TEMPERATURE CONTROL PANEL

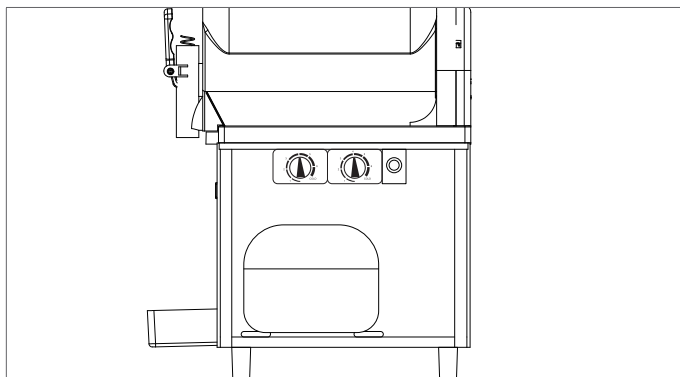

### Temperature Controls are located on back of unit.

1. To access Temperature Controls, unscrew the back panel cover.
2. Lift the panel cover

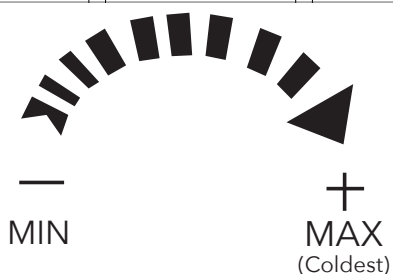

3. Turn the dial to adjust coldness:
  - \* Clockwise for the Max (Coldest) setting.
  - \* Counter-Clockwise for Minimum Coldness.
4. Replace panel cover and screws after adjustments are made.



## REPAIR AND MAINTENANCE

- Inspection, testing, and repair of electrical equipment should be performed only by qualified service personnel.
- Where electrical components are being changed, they shall be fit for the purpose and to the correct specification. At all times, the manufacturer's maintenance and service guidelines shall be followed. If in doubt, consult the manufacturer's technical department or qualified service personnel for assistance.
- Repair and maintenance to electrical components shall include initial safety checks and component inspection procedures. If a fault exists that could compromise safety, then no electrical supply shall be connected to the circuit until it is satisfactorily dealt with. If the fault cannot be corrected immediately but it is necessary to continue operation, an adequate temporary solution shall be used. This shall be reported to the owner of the equipment, so all parties are advised.
- Initial safety checks shall include:
  - \* That capacitors are discharged: this shall be done in a safe manner to avoid possibility of sparking;
  - \* That no live electrical components and wiring are exposed while charging, recovering or purging the system;
  - \* That there is continuity of earth bonding.
- When repairs to sealed components are made:
  - \* During repairs to sealed components, all electrical supplies shall be disconnected from the equipment being worked upon prior to any removal of sealed covers, etc.
  - \* If it is absolutely necessary to have an electrical supply to equipment during servicing, then a permanently operating form of leak detection shall be located at the most critical point to warn of a potentially hazardous situation.
- Particular attention shall be paid to the following to ensure that by working on electrical components, the casing is not altered in such a way that the level of protection is affected. This shall include damage to cables, excessive number of connections, terminals not made to original specification, damage to seals, incorrect fitting of glands, etc.
- Ensure that the apparatus is mounted securely.
- Ensure that seals or sealing materials have not degraded to the point that they no longer serve the purpose of preventing the ingress of flammable atmospheres. Replacement parts shall be in accordance with the manufacturer's specifications.
- Repair to intrinsically safe components:
  - \* Do not apply any permanent inductive or capacitance loads to the circuit without ensuring that this will not exceed the permissible voltage and current permitted for the equipment in use.
  - \* Intrinsically safe components are the only types that can be worked on while live in the presence of a flammable atmosphere. The test apparatus shall be at the correct rating.
  - \* Replace components only with parts specified by the manufacturer. Other parts can result in the ignition of refrigerant in the atmosphere from a leak.
- Check that cabling will not be subject to wear, corrosion, excessive pressure, vibration, sharp edges, or any other adverse environmental effects. The check shall also take into account the effects of aging or continual vibration from sources such as compressors or fans.

## DAILY CLEANING REQUIRED

-  **WARNING:** Disconnect the unit from its power supply prior to performing any maintenance.
  - \* Failure to do so could result in electric shock, injury from hazardous moving parts or serious burns from hot surfaces.
- Clean unit daily to optimize performance or when using dairy products.
- Regular cleaning of bowl components and removing dried-on beverage solids and pulp from moving sealed parts will result in maximum efficiency.

- It is absolutely necessary to frequently and carefully perform the cleaning and sanitizing operations as described below.
- **CAUTION:** DO NOT USE ANY POWDERS OR ABRASIVE CLEANING COMPOUNDS THAT WILL DAMAGE THE FINISH.
- **DO NOT** put any food zone parts in dishwasher.
  - \* Dishwasher may damage some parts such as the clear plastic auger gears and top gasket.
-  **WARNING: DO NOT** remove the white stirrer when filling the bowl with water or beverage!

## CLEANING INSTRUCTIONS

1. Turn off the equipment
2. Drain remaining product.
3. Fill the bowl with warm water and flush using dispensing valve until clear water flows from the spout.

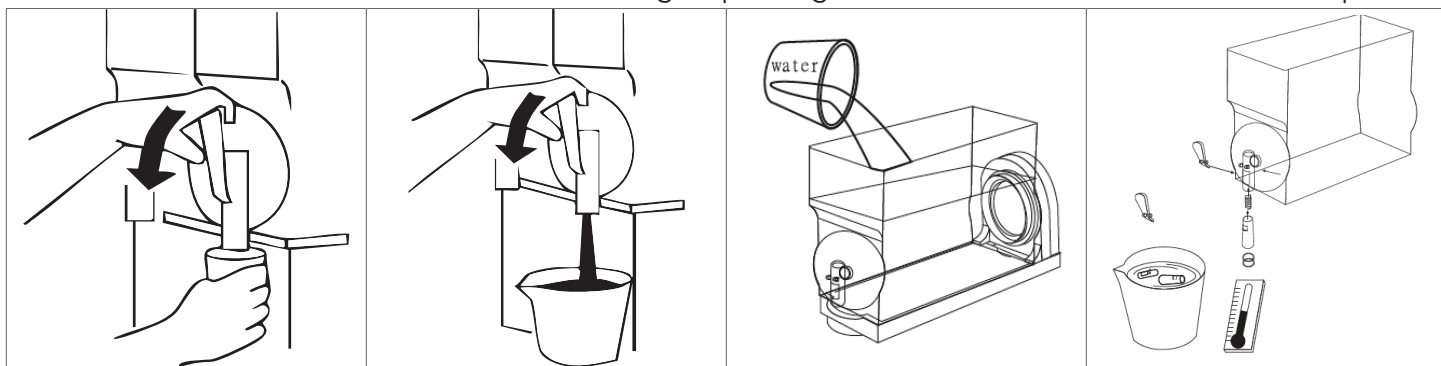

4. Drain the water prior to proceeding to the next step.

5. To disassemble the draw valve:
  - \* Extract the pin from its seat and the rest of the parts will come out.
  - \* Wash them with care in warm water.

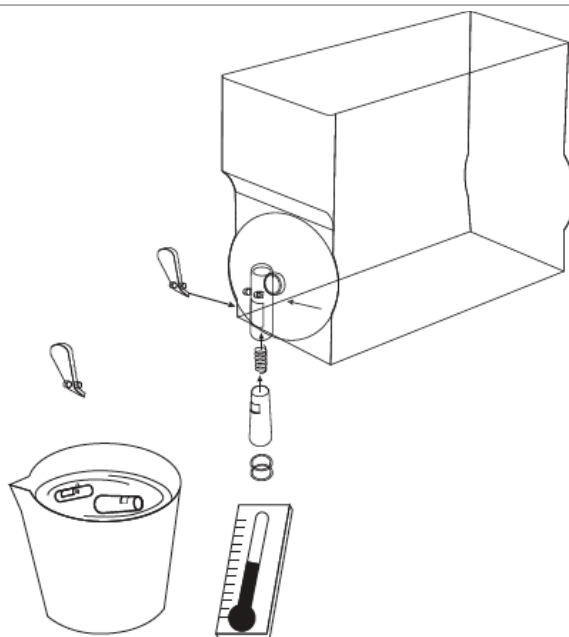

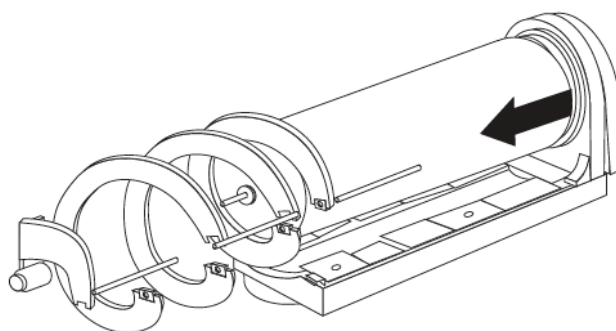
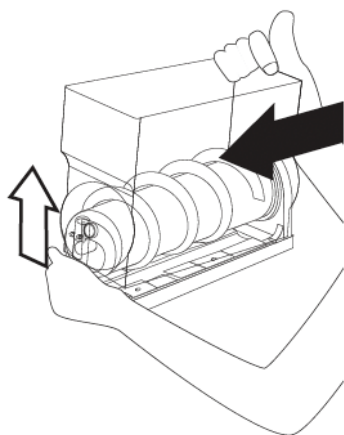

6. Remove the top part of the fluid pin assembly while holding the lever.
  - \* The pieces will separate.
7. Remove bowl.
  - \* Lift bowl up and over the evaporator.
8. Remove the gasket.
  - \* Rinse the bowl with warm water and mild detergent.
  - \* Do not place in dishwasher or use harsh chemicals.
  - \* Once rinsed, apply a light coating of food grade grease lubricant on the gasket and then place the gasket back on the bowl base.
9. Remove the o-ring from the fluid-pin and wash both parts separately, then reassemble the fluid-pin.

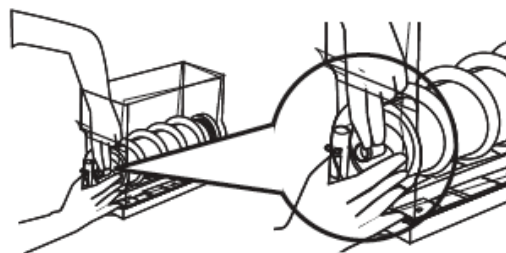
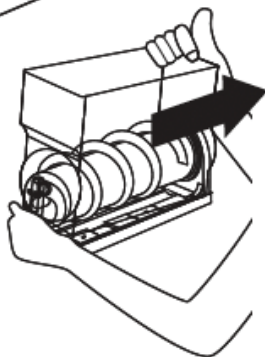
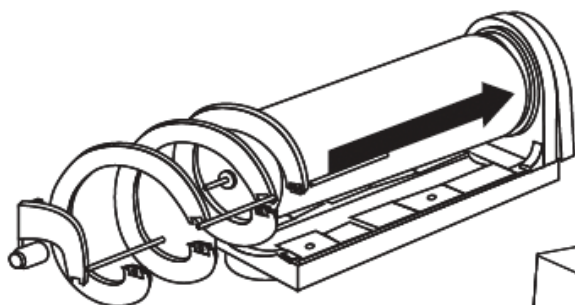



10. Wipe down the evaporator barrel with a clean, damp cloth.
11. Remove the drip tray and drip tray cover.
12. Pour out any excess product and wash with warm, soapy water.
13. Place drip tray cover back on the drip tray and slide back into machine.

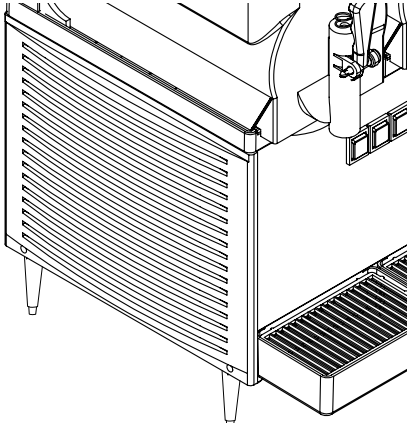

## CLEAN THE CONDENSER - MONTHLY

-  **WARNING:** Disconnect the unit from its power supply prior to performing any maintenance.
  - \* Failure to do so could result in electric shock, injury from hazardous moving parts or serious burns from hot surfaces.

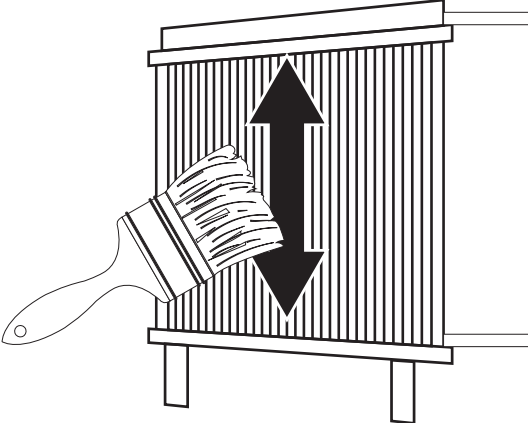
\* Failure to maintain a clean condenser will cause damage to the unit not covered by warranty.

		
<p>1. To access the Condenser coils, unscrew the side panel cover.</p>	<p>2. Remove the side panels.</p>	<p>3. Use a soft bristle brush to clean the condenser in an up/down direction.</p>

## REMOVING LIME SCALE

- 
**WARNING:** Disconnect the unit from its power supply prior to performing any maintenance.
  - \* Failure to do so could result in electric shock, injury from hazardous moving parts or serious burns from hot surfaces
- 
**WARNING:** Wear rubber gloves and safety goggles (and/or face shield) when handling descaler or sanitizer.
- This procedure must be performed a minimum of once every six months.

## REMOVE SCALE DEPOSITS FROM REMOVED PARTS.

- Mix 16 oz Manitowoc ice machine cleaner / descaler (Model # 9405463) or an equivalent cleaning agent with one gallon of potable water in a three-compartment sink.
- Place the plastic parts in the solution and allow to soak for 10-15 minutes.
- Use a soft bristle brush on heavy scale or mineral buildup as required.
- Clean scale deposits from surface areas of evaporator and the inside of bowl.
- Use a clean soft cloth or sponge soaked in cleaner / descaler solution to wipe evaporator surfaces and the inside of bowl.
  - \* NOTICE: **NEVER** expose electrical connectors to any liquids.

## SANITIZING PROCEDURE

- 
**WARNING:** Disconnect the unit from its power supply prior to performing any maintenance procedures.
  - \* Failure to do so could result in electric shock, injury from hazardous moving parts or serious burns from hot surfaces.
- This procedure must be performed a minimum of once every six months.

### Sanitize plastic parts:

- Mix two ounces of Manitowac ice machine sanitizer (Model # 9405653) or an equivalent cleaning agent with three gallons of potable water in a three compartment sink. Add five gallons of clear potable water to third sink compartment.
- Remove plastic parts from cleaner / descaler solution & rinse in clear potable water.

3. Place the plastic parts in the sanitizer solution and allow to soak for at least one minute.

## Sanitize surface areas of evaporator and the inside of bowl:

1. Use a clean sanitizer-soaked towel to wipe and sanitize surface area of evaporator and the inside of bowl.
2. Manitowoc sanitizer is classified as a no rinse sanitizer. Do not rinse sanitized surfaces of appliance.  
\* NOTICE: **NEVER** expose electrical connectors to any liquids.

## HOW TO PREVENT FROZEN OR FROSTED EVAPORATOR

- To prevent evaporator from freezing, the drink mixture should always be kept higher than the low water level limit.
- A frozen evaporator will seriously damage the mixing parts, as well as the stirring motors.

## CAUTION:

- If the evaporator is frozen, turn off the power and unplug the appliance first.
- Make sure the frost or frozen ice is melt completed.
- Never touch the frozen evaporator by hand. It will cause an injury.
- For sanitary reasons, **ALWAYS** drain out all the leftover mixture. Refill with fresh mixture and start the appliance again.

## CIRCUIT DIAGRAMS

ADC2BFG - Double Bowl Unit

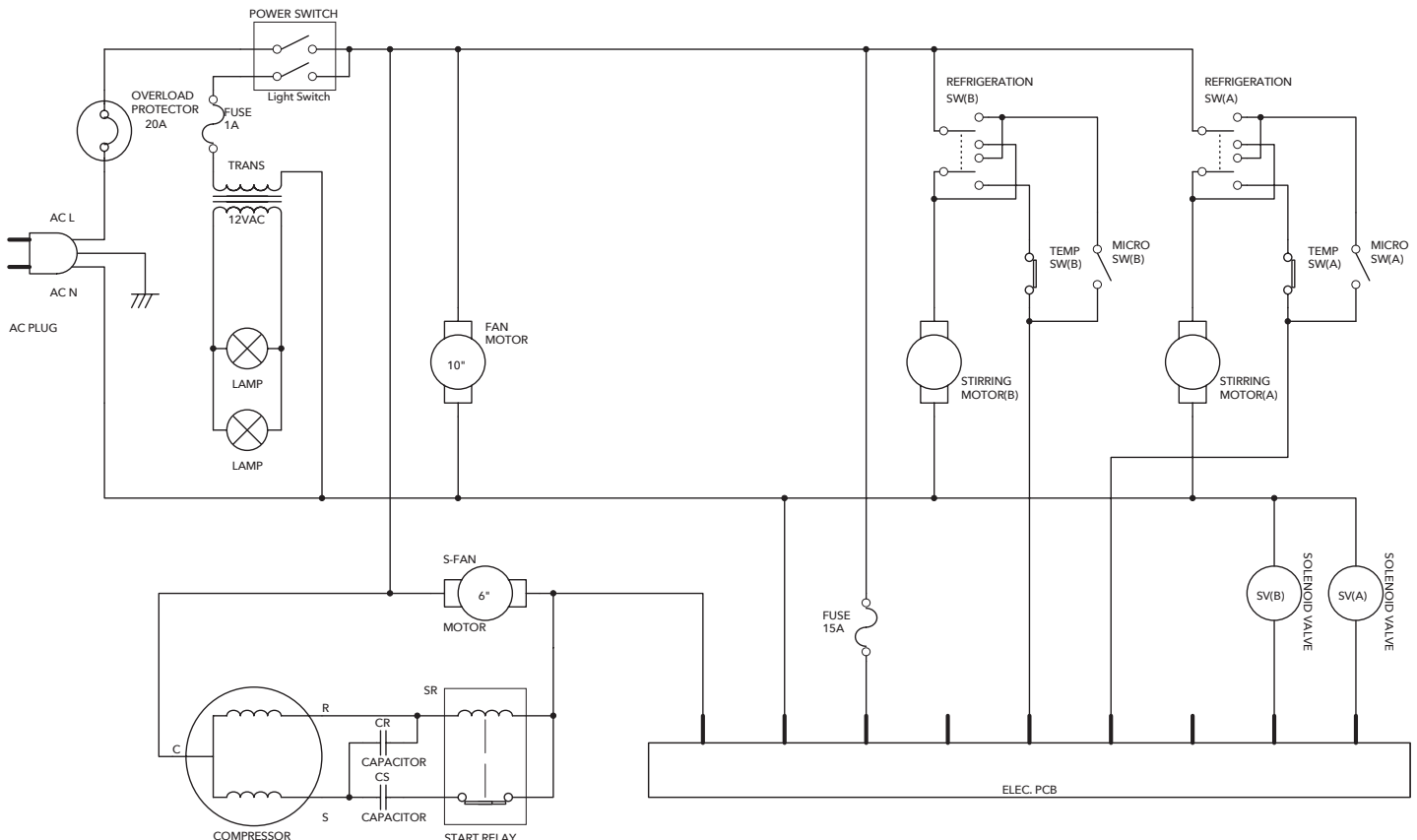

## ADC3BFG - Triple Bowl Unit

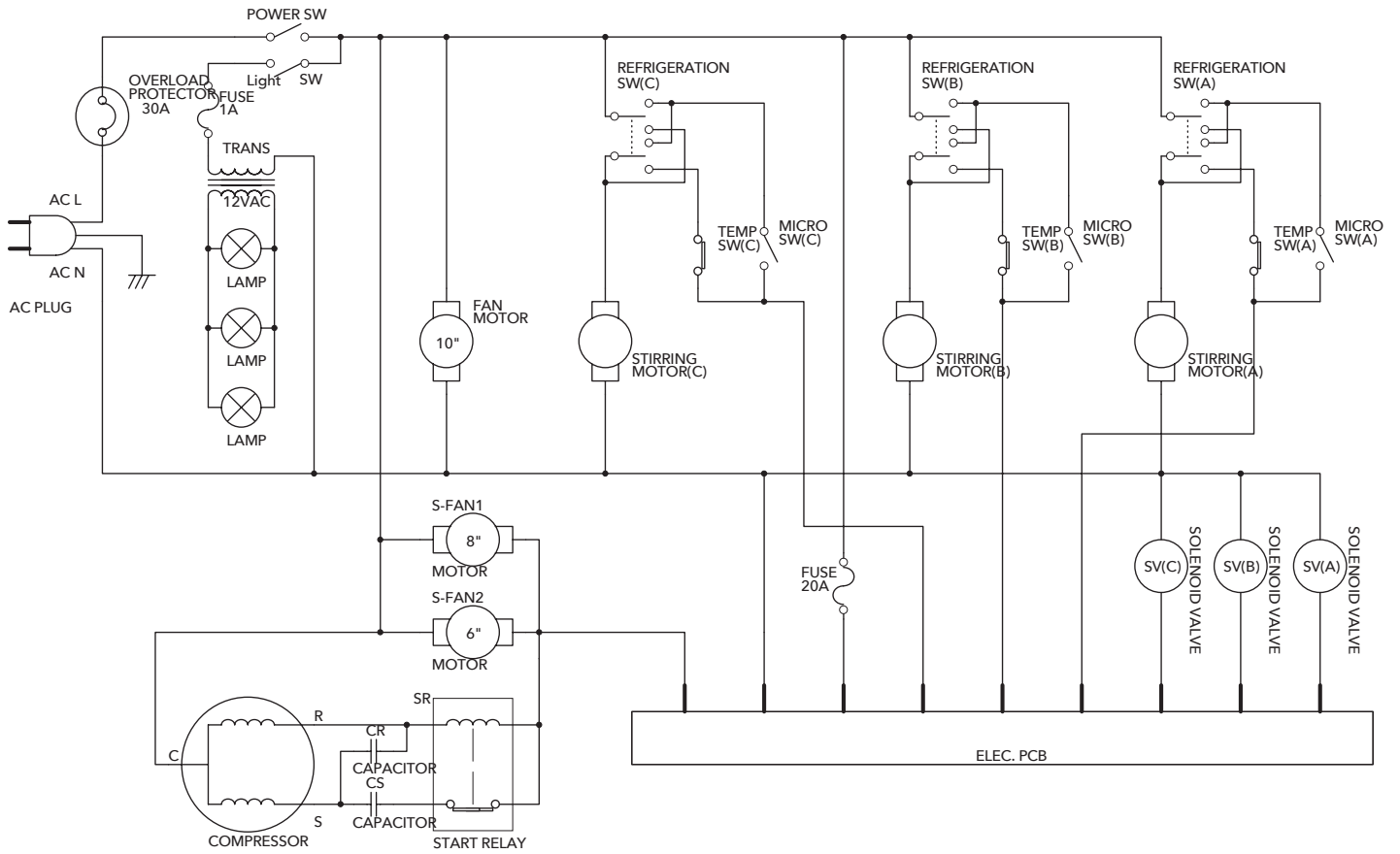



## 1-YEAR LIMITED WARRANTY

Admiral Craft Equipment Corp. (the "Company") warrants this product (the "Product") will be free from failures in material and workmanship for one (1) year from the date of original purchase with proof of purchase, provided that the Product is operated and maintained in conformity with the Owner's Manual. This Limited Warranty is non-transferable. During this period, your exclusive remedy is repair or replacement without charge of the Product or any component found to be defective at the Company's discretion. If the Product or any component is no longer available, the Company will replace it with a similar one of equal or greater value. This Limited Warranty is void if the Product is used with voltage other than 120 Volts. **THIS WARRANTY IS IN LIEU OF ALL IMPLIED WARRANTIES, INCLUDING WARRANTIES OF MERCHANTABILITY, FITNESS FOR A PARTICULAR PURPOSE, PERFORMANCE, OR OTHERWISE, WHICH ARE HEREBY EXCLUDED. IN NO EVENT SHALL THE COMPANY BE LIABLE FOR ANY DAMAGES, WHETHER DIRECT, INDIRECT, INCIDENTAL, FORESEEABLE, CONSEQUENTIAL, OR SPECIAL ARISING OUT OF OR IN CONNECTION WITH THIS PRODUCT INCLUDING DAMAGES ARISING FOR FOOD OR BEVERAGE SPOILAGE CLAIMS.**

You may have other legal rights depending upon where you live. Some States or Provinces do not allow limitations on warranties so the foregoing may not apply to you.

## WARRANTY EXCLUSIONS

---

### IMPROPER ELECTRICAL CONNECTIONS:

The Company is not responsible for the repair or replacement of failed or damaged components resulting from electrical power failure, the use of extension cords, low voltage, or voltage spikes to the Product.

### IMPROPER USAGE:

This Limited Warranty does not cover failure or other damages to the Product resulting from (i) improper usage or installation or failure to clean and/or maintain the Product as set forth in the Owner's Manual; or (ii) accident, misuse, abuse, negligence, or modification or alteration of the Product.

### CONSUMABLES:

This Limited Warranty does not include consumables or wear-and-tear items such as legs, feet, plastic component parts, splash shields, filters, gaskets, and non-stick cooking surfaces.

### ADJUSTMENTS & CALIBRATIONS:

Leveling, tightening of fasteners, or utility connections normally associated with the original installation are the responsibility of the dealer, installer, or the end user and not the responsibility of the Company and will not be considered warranty issues.

If you think the Product has failed, or requires service, within its warranty period, please contact the Company's Customer Care Department through our website at: [www.admiralcraft.com](http://www.admiralcraft.com) "Service" --> "Technical Support Request". A receipt proving the original purchase date will be required for all warranty claims, handwritten receipts are not accepted. You may also be required to return the Product for inspection and evaluation. Return shipping costs are not refundable. The Company is not responsible for returns lost in transit.

This Limited Warranty is Valid only in the USA and Canada.