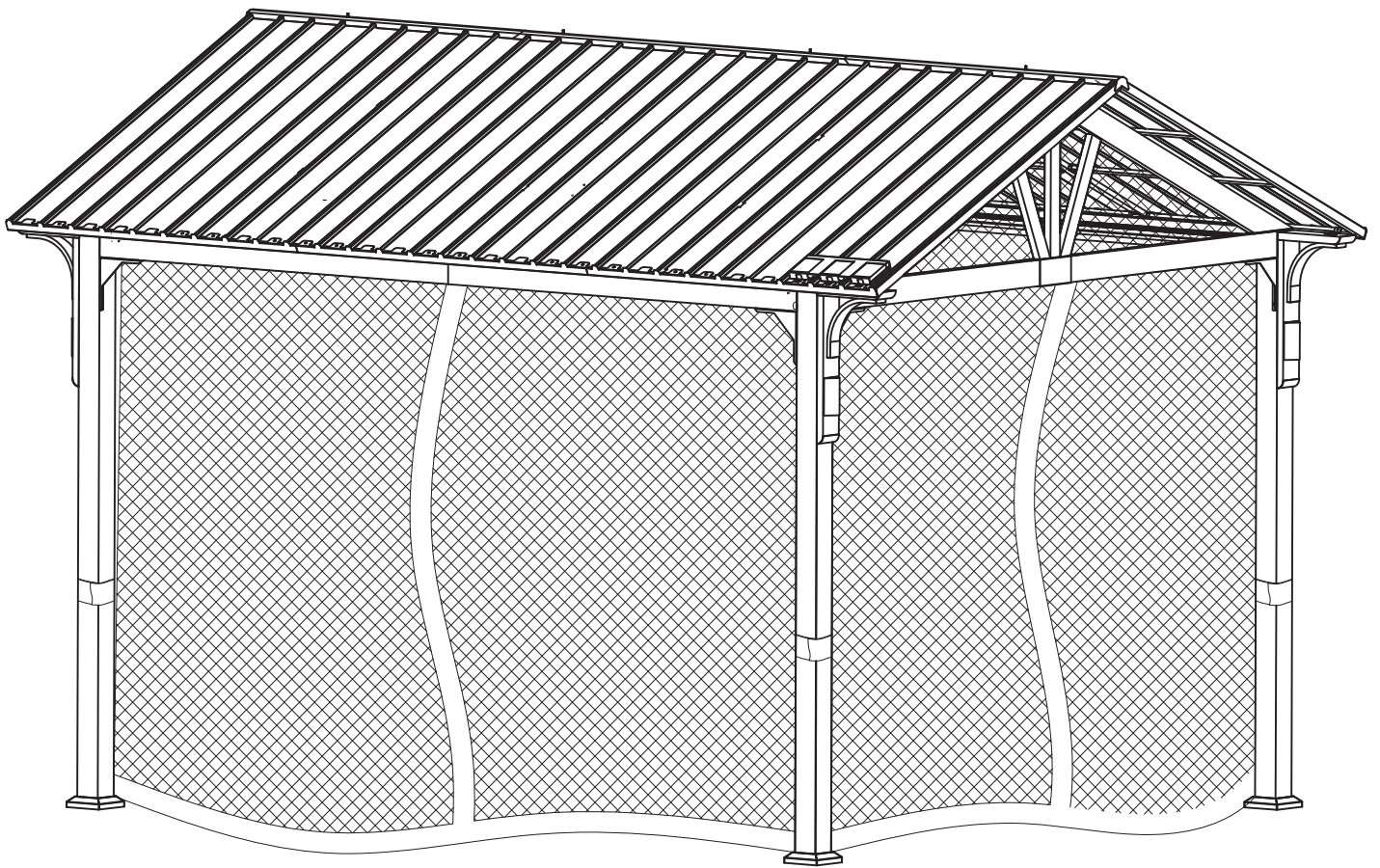


BACKYARD *Creations*®

VESTAVIA 10'×12' GABLE GAZEBO WITH SOLAR
LED LIGHTS AND NETTING

Style# GFS60014J-M1/GFS60014J-M2

SKU # 272-3020/272-3021



>>assembly instructions

Warranty

1 YEAR LIMITED FRAME WARRANTY.

WHAT IS COVERED

We warrant the frames to be free of manufacturing defects to the original purchaser for one year, and a one year limited warranty for the fabric.

WHAT IS NOT COVERED

It remains the customer's responsibility for freight and packaging charges to and from our service center. This warranty does not cover commercial use, hardware, acts of nature, fire, freezing and abusive use. In addition, purchased parts are not covered under this warranty. We reserve the right to make substitutions with similar merchandise, if the model in question is no longer in production.

WARNING

For your own safety, and to reduce the risk of serious personal injury, the user must read and understand this Use and Care Guide, and assemble each piece only in accordance with these instructions and with the parts and hardware included with the original packaging.

Failure to follow these instructions and/or use of tools or hardware not included in the original packaging may lead to improper assembly and/or risk of serious personal injury.

WARNING

KEEP PLASTIC BAGS AND SMALL PARTS AWAY FROM CHILDREN. DO NOT USE POWER TOOLS. DO NOT OVERTIGHTEN HARDWARE. PERIODICALLY CHECK HARDWARE AND RE-TIGHTEN AS NECESSARY. DO NOT USE PRODUCT IF ANY COMPONENT BECOMES DAMAGED. FOR RESIDENTIAL (NON-COMMERCIAL) USE ONLY. DO NOT STAND ON PRODUCT. USE ONLY FOR INTENDED PURPOSES.

CARE AND CLEANING

FRAME: WIPE CLEAN WITH A MILD SOAP AND WATER SOLUTION, RINSE WITH CLEAN WATER, AND DRY THOROUGHLY.

IMPORTANT

ASSEMBLE ON A STABLE LEVEL SURFACE TO AVOID DAMAGE TO GAZEBO AND POSSIBLE INJURY.

TWO PEOPLE ARE REQUIRED TO ASSEMBLE THIS PRODUCT. INSTALL ALL BOLTS BY HAND LOOSELY THREADED BEFORE FULLY TIGHTENING ANY BOLTS. ONCE ALL BOLTS ARE INSTALLED LOOSELY, THEN SECURE THE BOLTS BEFORE MOVING ON TO NEXT STEP.


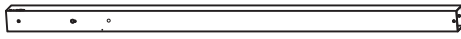

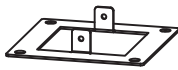

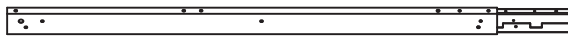
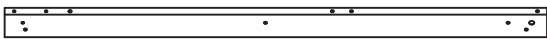
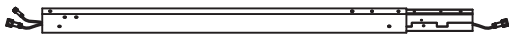
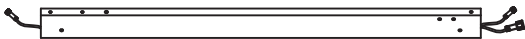






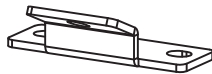
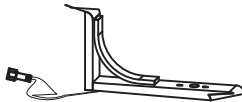
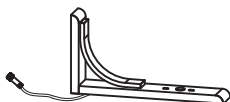
IF YOU HAVE ANY QUESTIONS OR CONCERNS PLEASE CALL US TOLL FREE AT 1-866-905-4107

MONDAY-FRIDAY 8:30 AM TO 5:00 PM PACIFIC TIME / 11:30 AM TO 8:00 PM EASTERN TIME.


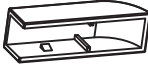

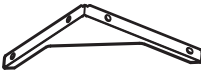


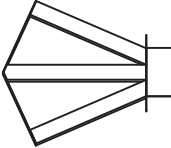
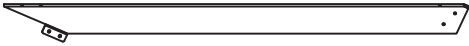


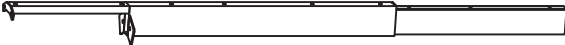

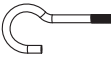

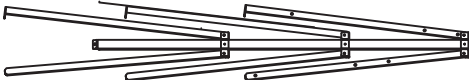
TABLE OF CONTENTS

Introduction	2-3
Parts List	5-8
Hardware	9
Tool Required	10
Assembly	11-60

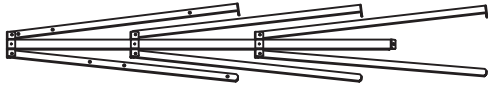




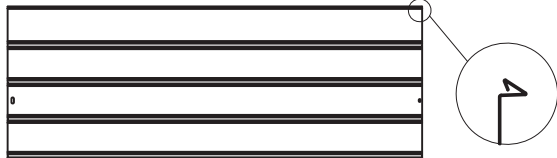
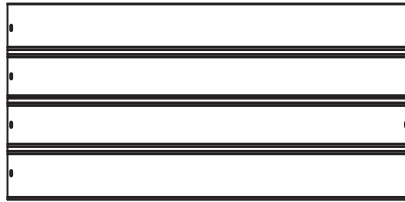
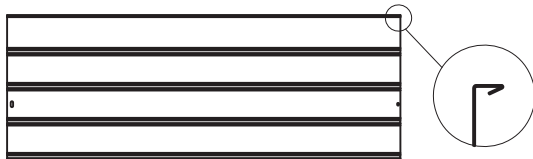
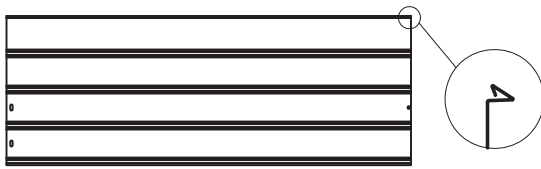



PARTS LIST

Part	QTY	PIECE	DESCRIPTION
A1	1		Post leg
A2	1		Post leg
A3	2		Post leg
B	4		Foot plate
C	4		Foot plate cover
D1	2		Long beam
D2	2		Long beam
D3	2		Short beam
D4	2		Short beam
E	4		Light strip tube
F	8	 	Short fiberglass rod
F1	8	 	Long fiberglass rod
F2	16		plastic
G	6		Middle inclined beam connector
H1	2		Corner connector
H2	2		Corner connector









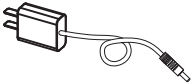
PARTS LIST

Part	QTY	PIECE	DESCRIPTION
H3	4		Down light
I1	4		Light bar plastic part
I2	2		Light bar
J	10		Gable support
K1	2		Top of post leg plate
K2	2		Top of post leg plate
L1	2		Gable
L2	2		Inclined beam
L3	2		Inclined beam
L4	2		Inclined beam connector
M1	2		Top beam
M2	1		Top beam
N	1		Hook
O	4		Roof connector
P1	2		Rafter branch unit

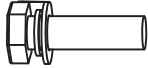



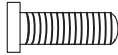
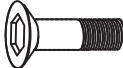


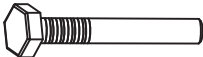




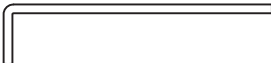

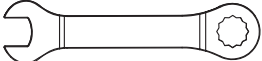
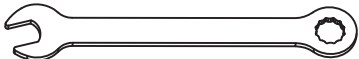
PARTS LIST

Part	QTY	PIECE	DESCRIPTION
P2	4		Rafter branch unit
P3	2		Rafter branch unit
Q1	2		Cross beam
Q2	2		Cross beam
Q3	2		Cross beam connector
R1	1		Roof panel
R2	10		Roof panel
R3	2		Roof panel
R4	1		Roof panel
S1	2		Roof top cover
S2	1		Roof top cover
T1	2		Roof edge cap

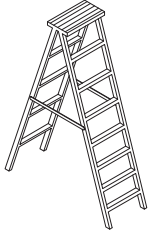
PARTS LIST

Part	QTY	PIECE	DESCRIPTION
T2	2		Roof edge cap
T3	2		Roof edge cap
U	4		Corble connector
V	1		Solar panel
Y1	2		Triangular netting
Y2	2		Triangular netting
Y3	1		Netting
Y4	44+8		Plastic hook
Z	1		Plug

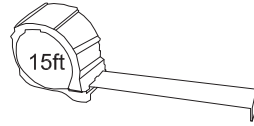
HARDWARE

Part	QTY	PIECE	DESCRIPTION
AA	16+1		M8*25 bolt with washer
BB	14+1		M6*8 bolt
CC	177+10		M6*15 bolt with washer
DD	8+1		M6*15 bolt
EE	24+2		M6*10 bolt
FF	8+1		M6*20 bolt
GG	14+1		M6*35 bolt with washer
HH	16+1		M6*65 bolt with washer
JJ	8+1		M8*75 bolt
KK	4+1		Double-end bolt
LL	4+1		washer
MM	4+1		Nut
NN	4+1		Nut cap
OO	8+1		Ground stake
PP	2		Allen wrench
QQ	1		Hex wrench
RR	1		Wrench

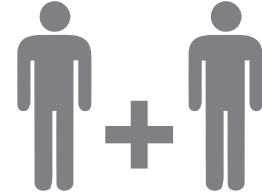
TOOLS REQUIRES



8' (2.4 m) Ladder
(QTY. 2 recommended)

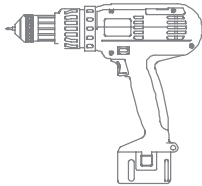


15' (4.6 m) Tape measure

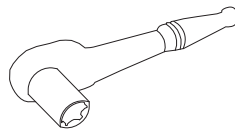


2
people

RECOMMENDED TOOLS



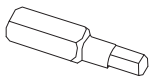
Cordless drill or
driver with 4 mm
hex head bit



Socket wrench with
10 mm socket



Driver bit extension
(4" recommended)

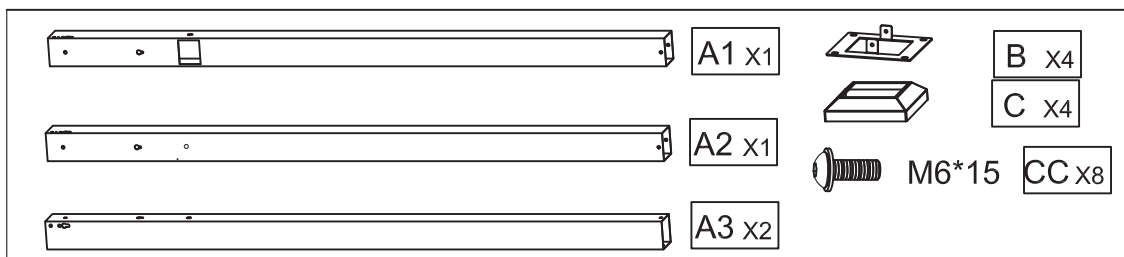
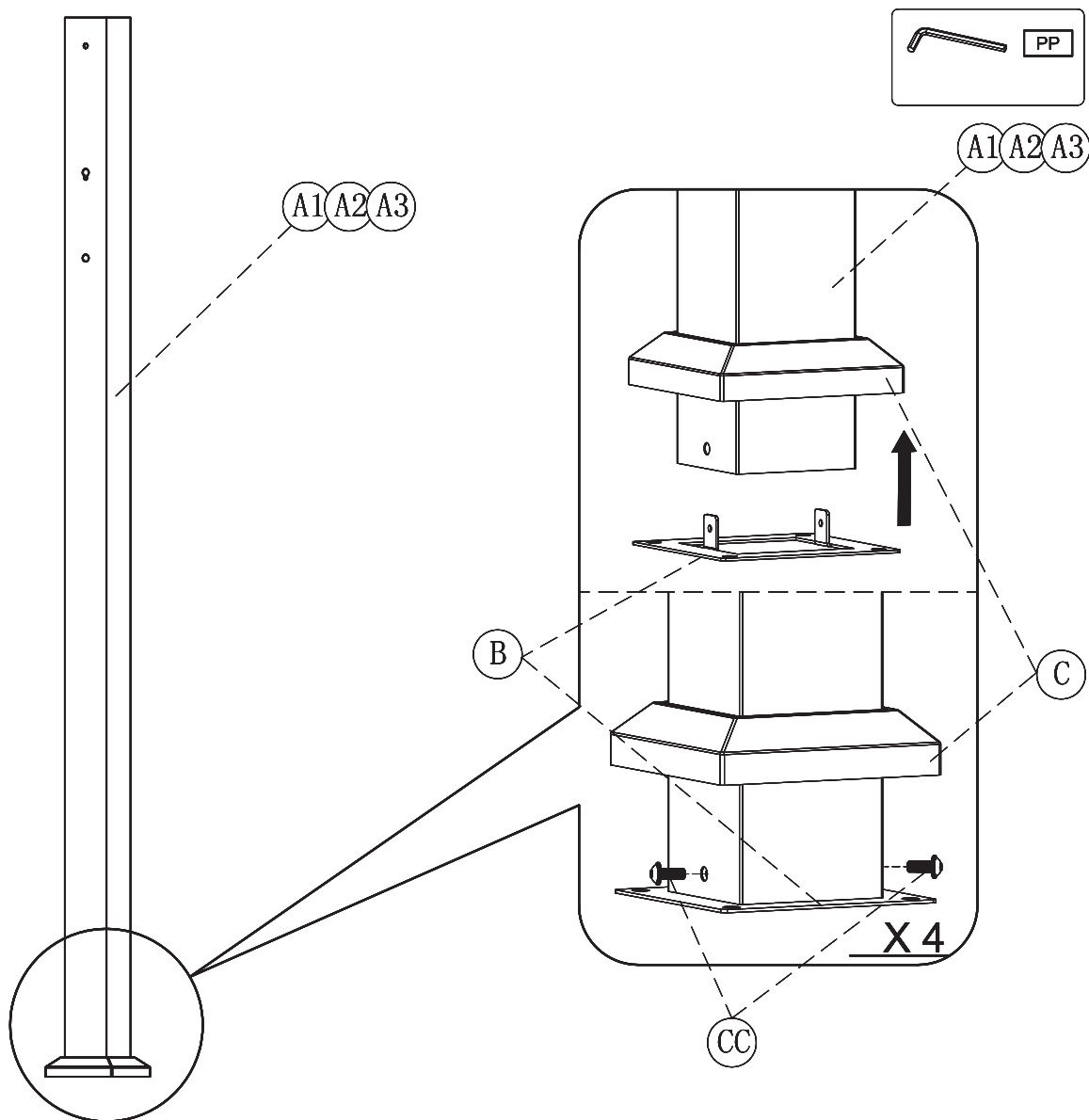


4 mm
hex bit

Step 1

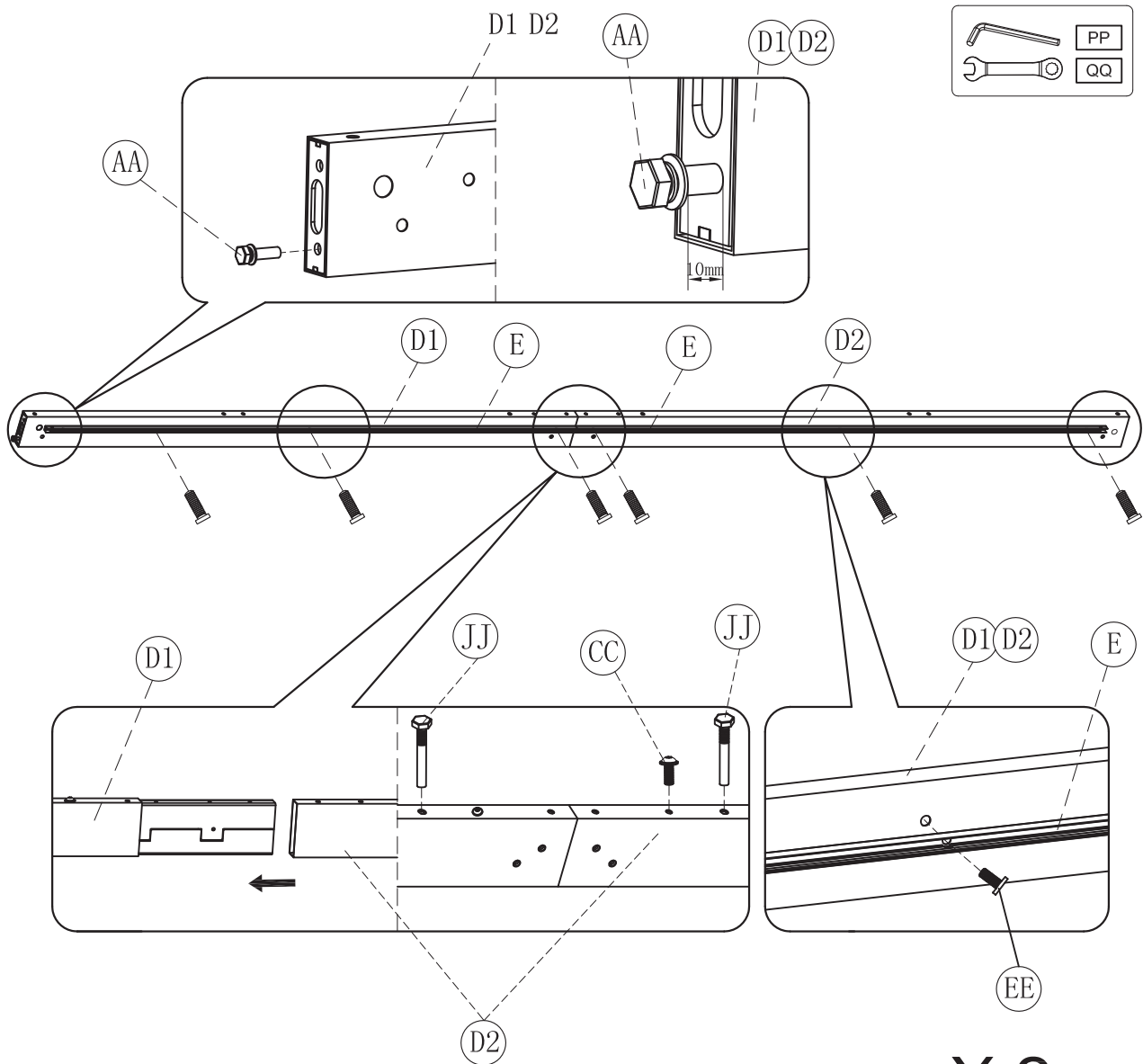
ATTENTION: To prevent damage during assembly, please use either the box carton or another soft material as a working surface.

1. Insert the Foot plate cover (C) into the Post leg (A1).
2. Attach the Foot plate (B) to the Post leg (A1) with M6*15 Bolt with washer (CC).
3. Tighten all bolts by using Allen wrench (PP).
4. Repeat this step for the remaining Post legs (A2) & (A3).



Step 2

1. Insert the Long beam (D2) into the Long beam (D1) with M6*15 bolt with washer (CC) & M8*75 bolt (JJ).
2. Attach the Light strip tube (E) to the Long beam (D1) & (D2) with M6*10 bolt (EE).
3. Use the M8*25 bolt (AA) on both sides of Long beam (D1) & (D2).
4. Tighten all bolts by using Allen wrench (PP) & Hex wrench (QQ).
5. Repeat this step for the remaining Long beam (D1) & (D2).

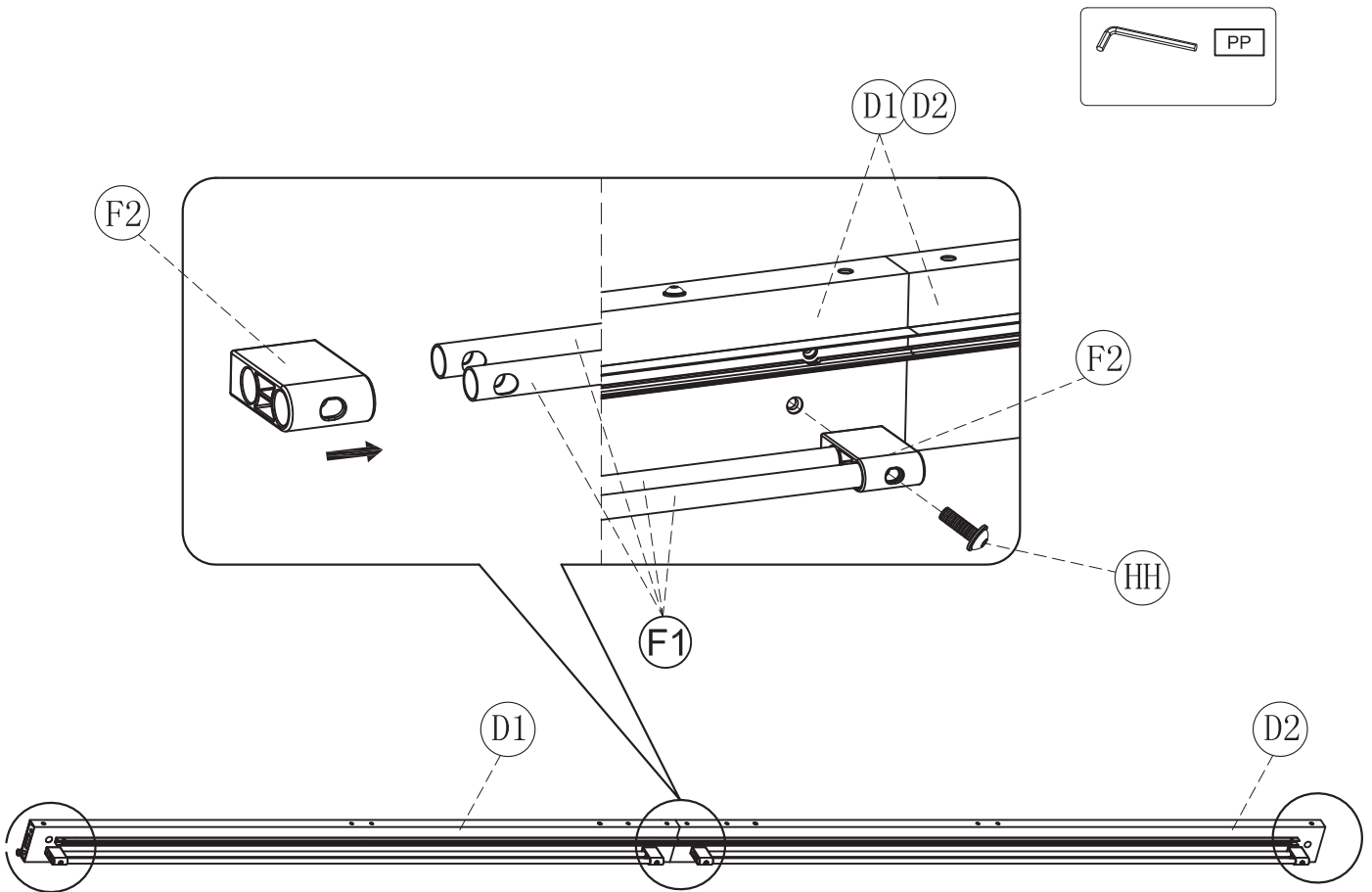


X 2

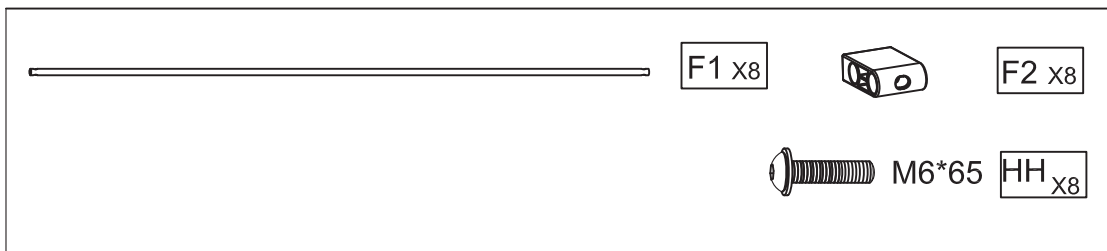
	D1 x2		M6*15 CC x2
	D2 x2		AA x4
	E x4		M6*10 EE x12
			M8*75 JJ x4

Step 3

1. Insert the Plastic (F2) into the two Long fiberglass rod (F1).
2. Attach the two Long fiberglass rod (F1) to the Long beam (D1) & (D2) with M6*65 bolt with washer (HH).
3. Tighten all bolts by using Allen wrench (PP).
4. Repeat this step for the remaining Long fiberglass rod (F1).

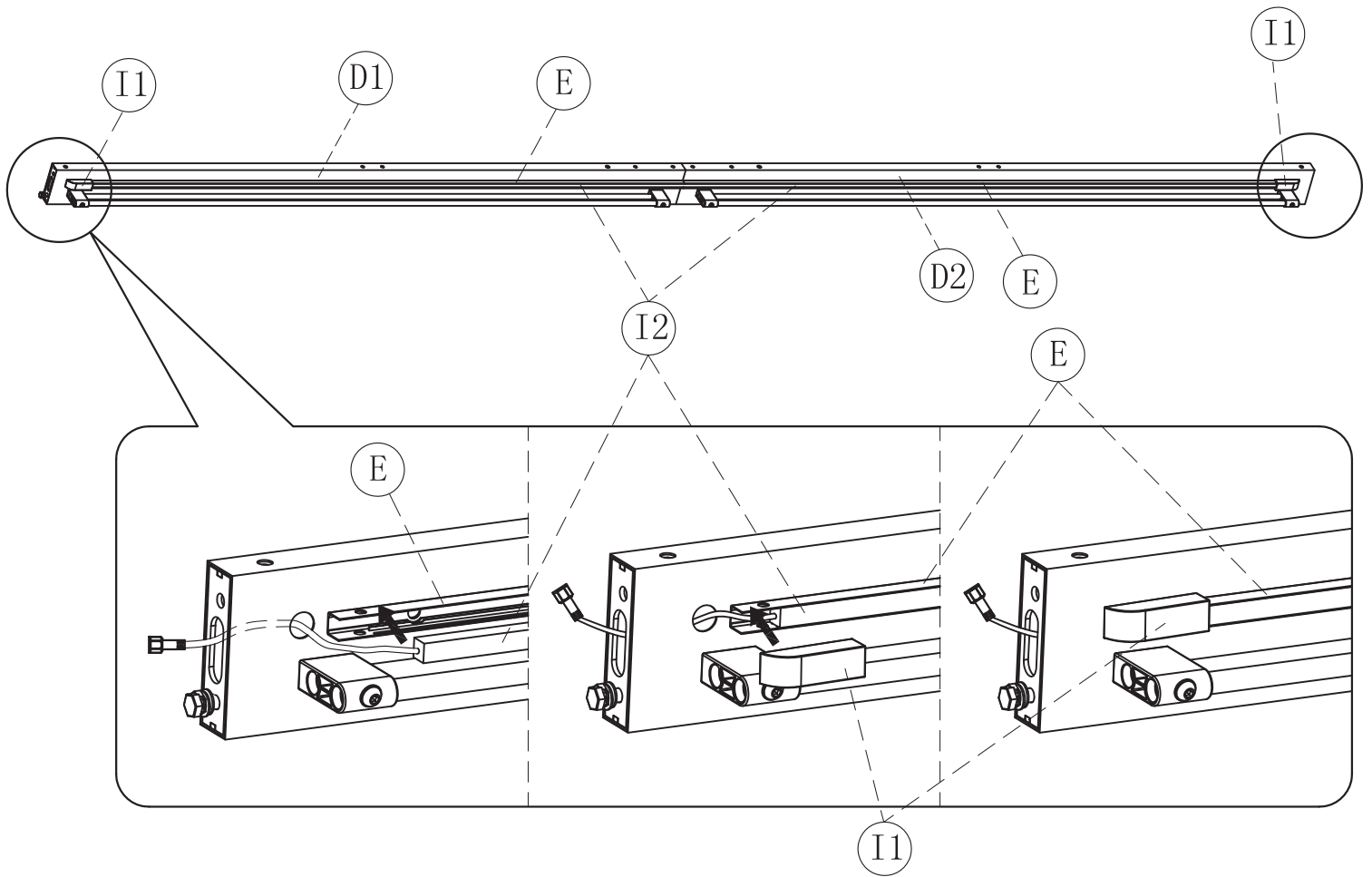


X 2

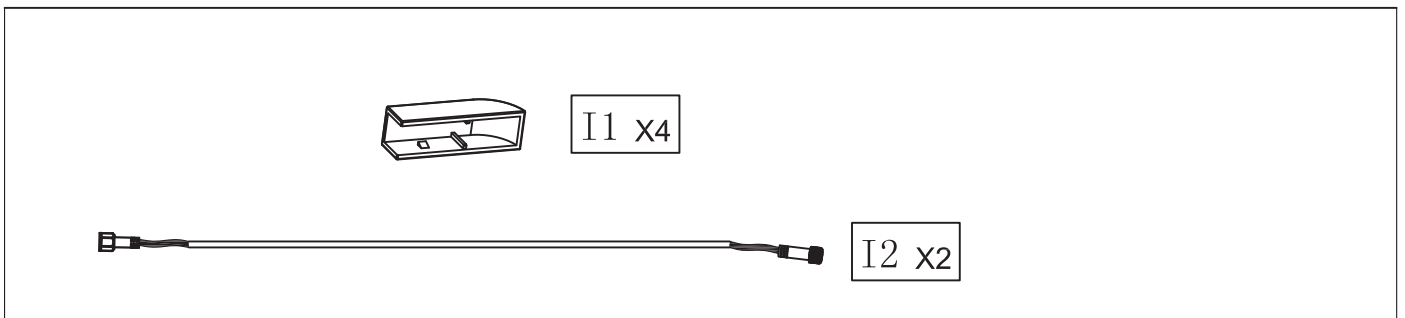


Step 4

1. Insert the Light bar (I2) into the Light strip tube (E).
2. Insert the Light bar plastic part (I1) into the Light strip tube (E).
3. Repeat this step for the remaining Light bar (I2)

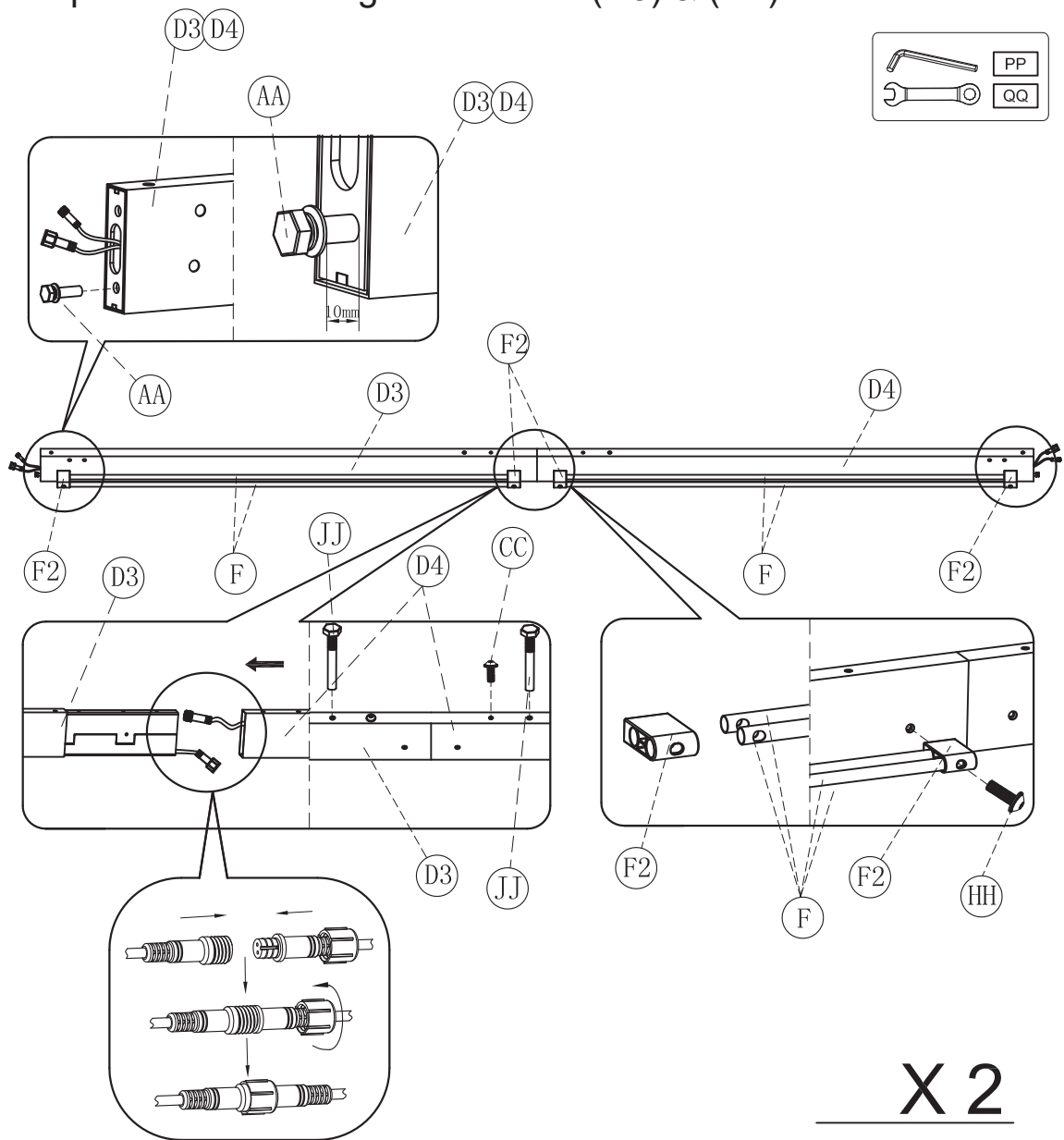


X 2



Step 5

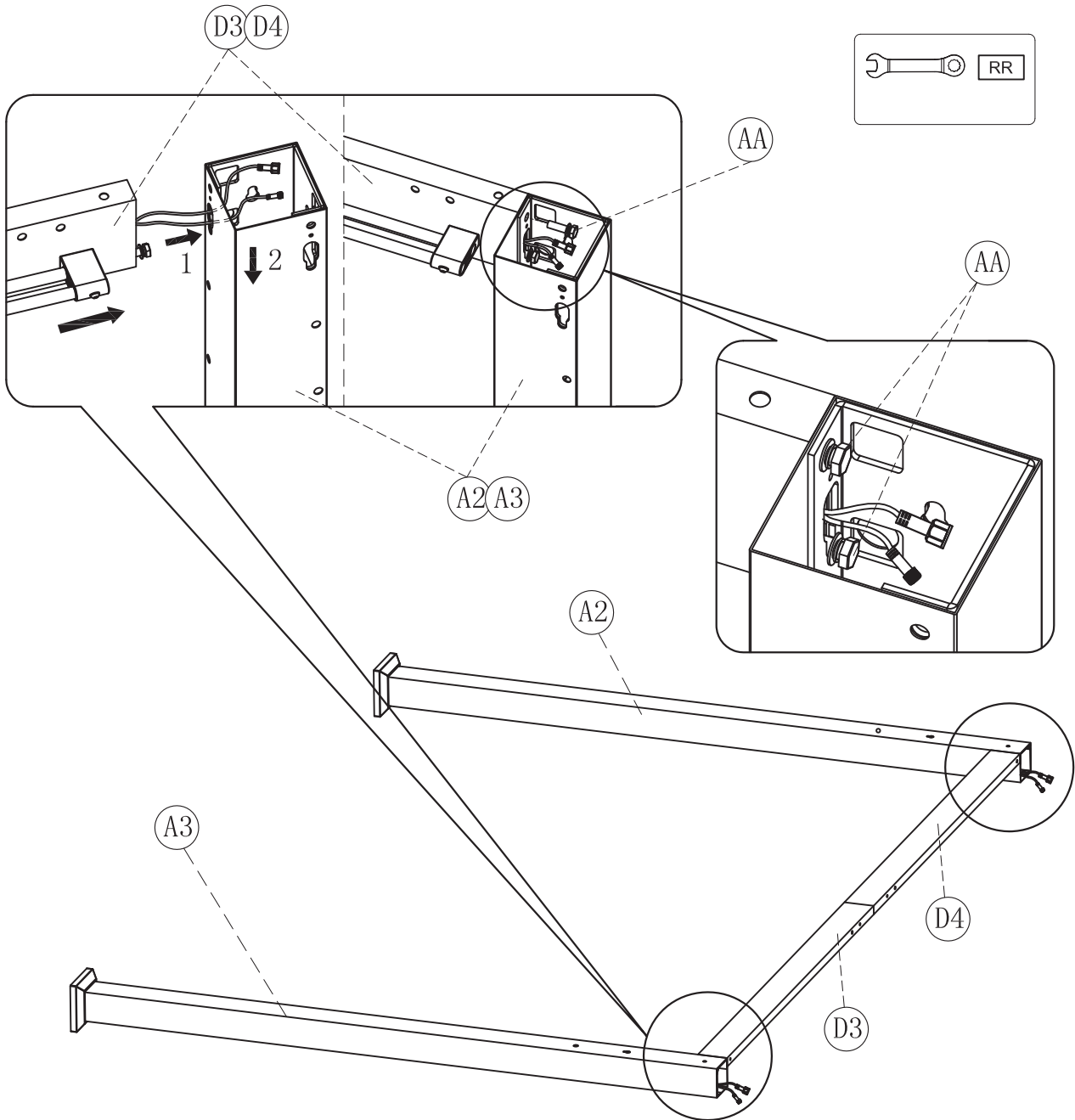
1. Connect the wires on the short beam.
2. Insert the Short beam (D4) into the Short beam (D3) with M6*15 bolt with washer (CC) & M8*75 bolt (JJ).
3. Insert the Plastic (F2) into the two Short fiberglass rod (F).
4. Attach the two Short fiberglass rod (F) to the Short beam (D3) & (D4) with M6*65 bolt with washer (HH).
5. Use M8*25 bolt with washer (AA) on both sides of Short beam (D3) & (D4).
6. Tighten all bolts by using Allen wrench (PP) & Hex wrench (QQ).
7. Repeat this step for the remaining Short beam (D3) & (D4).



	D3 x2		F2 x8
	D4 x2		AA x4
	F x8		JJ x4
	HH x8		CC x2

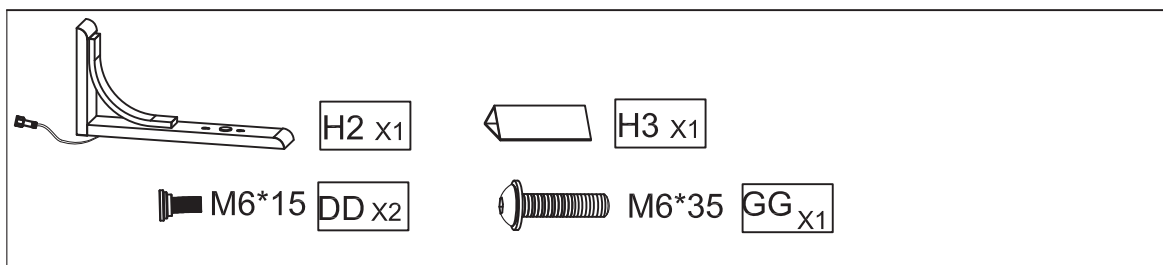
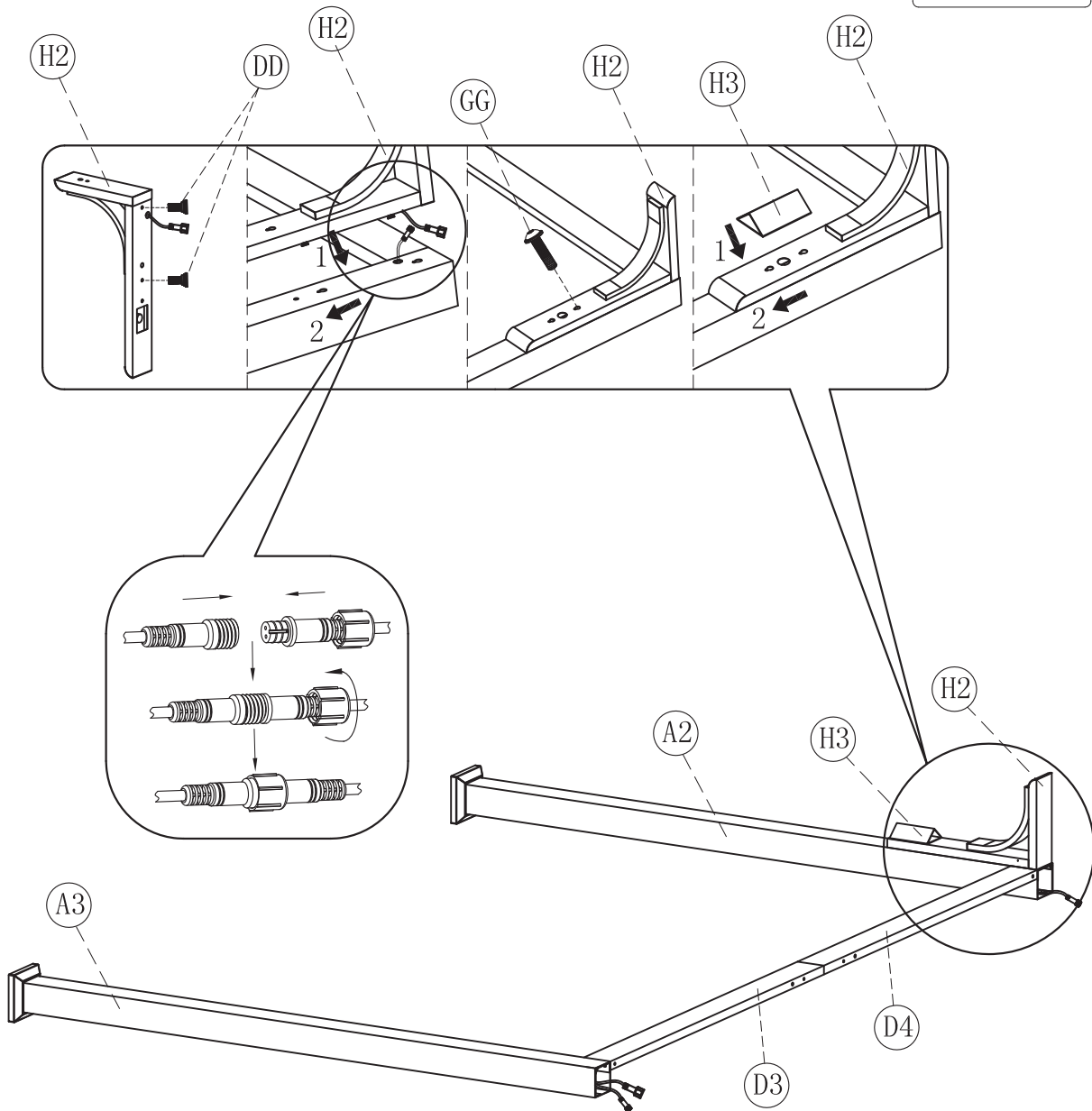
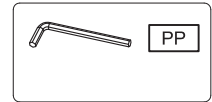
Step 6

1. Attach the Short beam (D3) & (D4) to the Post leg (A3) & (A2) with M8*25 bolt with washer (AA).
2. Tighten all bolts by using Wrench (RR)



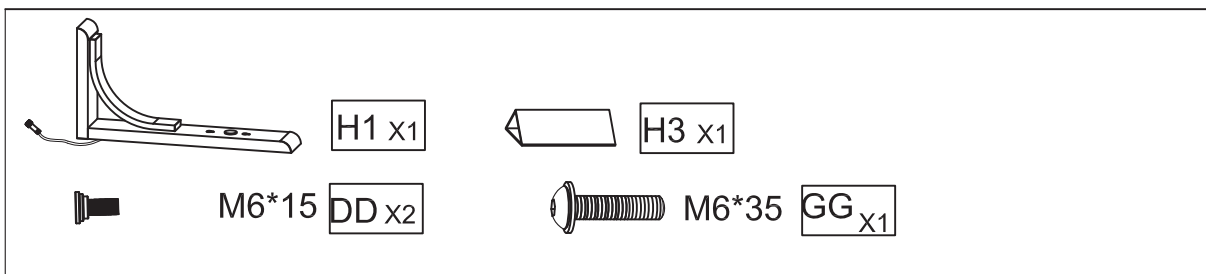
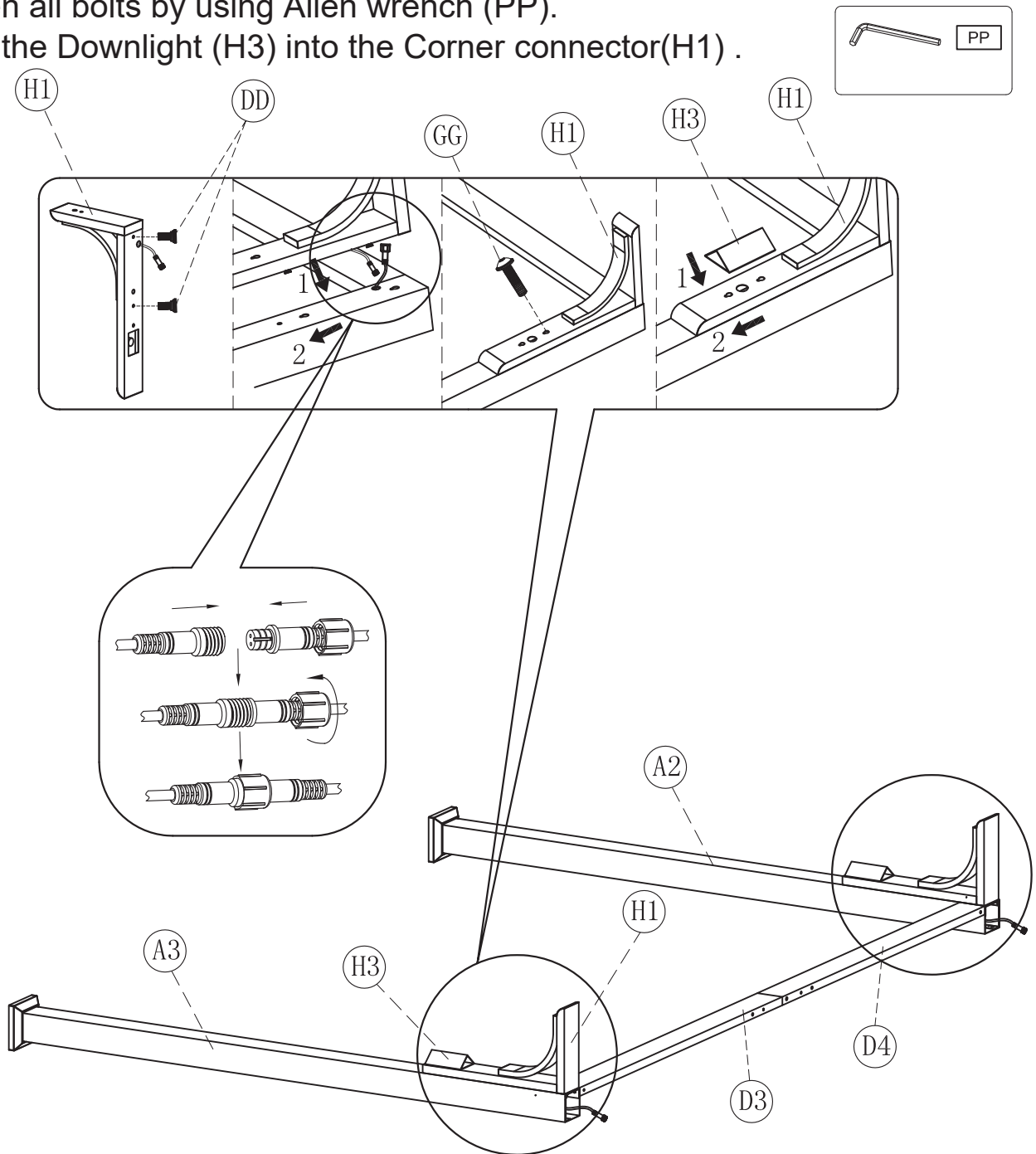
Step 7

1. Use the M6*15 bolt (DD) on the Corner connector (H2).
2. Connect the wires of Short beam (D4) & Corner connector (H2), then insert the wires into the Post leg (A2).
3. Insert the Corner connector (H2) into the Post leg (A2) with M6*35 bolt with washer (GG).
4. Tighten all bolts by using Allen wrench (PP).
5. Insert the Downlight (H3) into the Corner connector (H2).



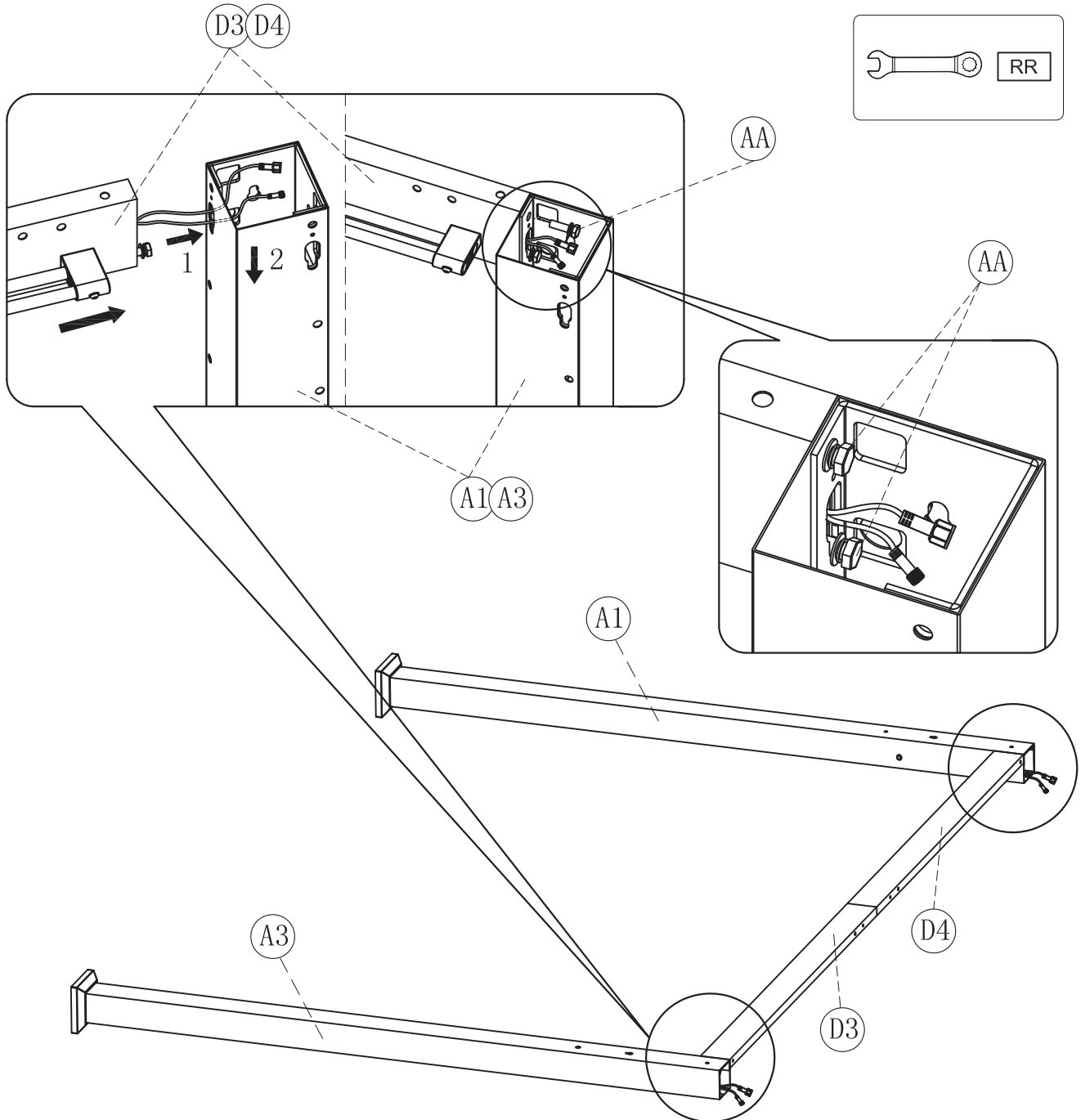
Step 8

1. Use the M6*15 bolt (DD) on the Corner connector (H1).
2. Connect the wires of Short beam (D3) & Corner connector (H1), then insert the wires into the Post leg (A3).
3. Insert the Corner connector (H3) into the Post leg (A3) with M6*35 bolt with washer (GG).
4. Tighten all bolts by using Allen wrench (PP).
5. Insert the Downlight (H3) into the Corner connector(H1) .



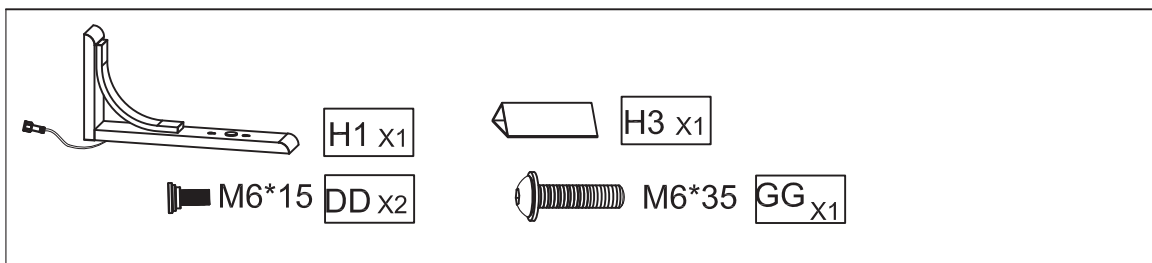
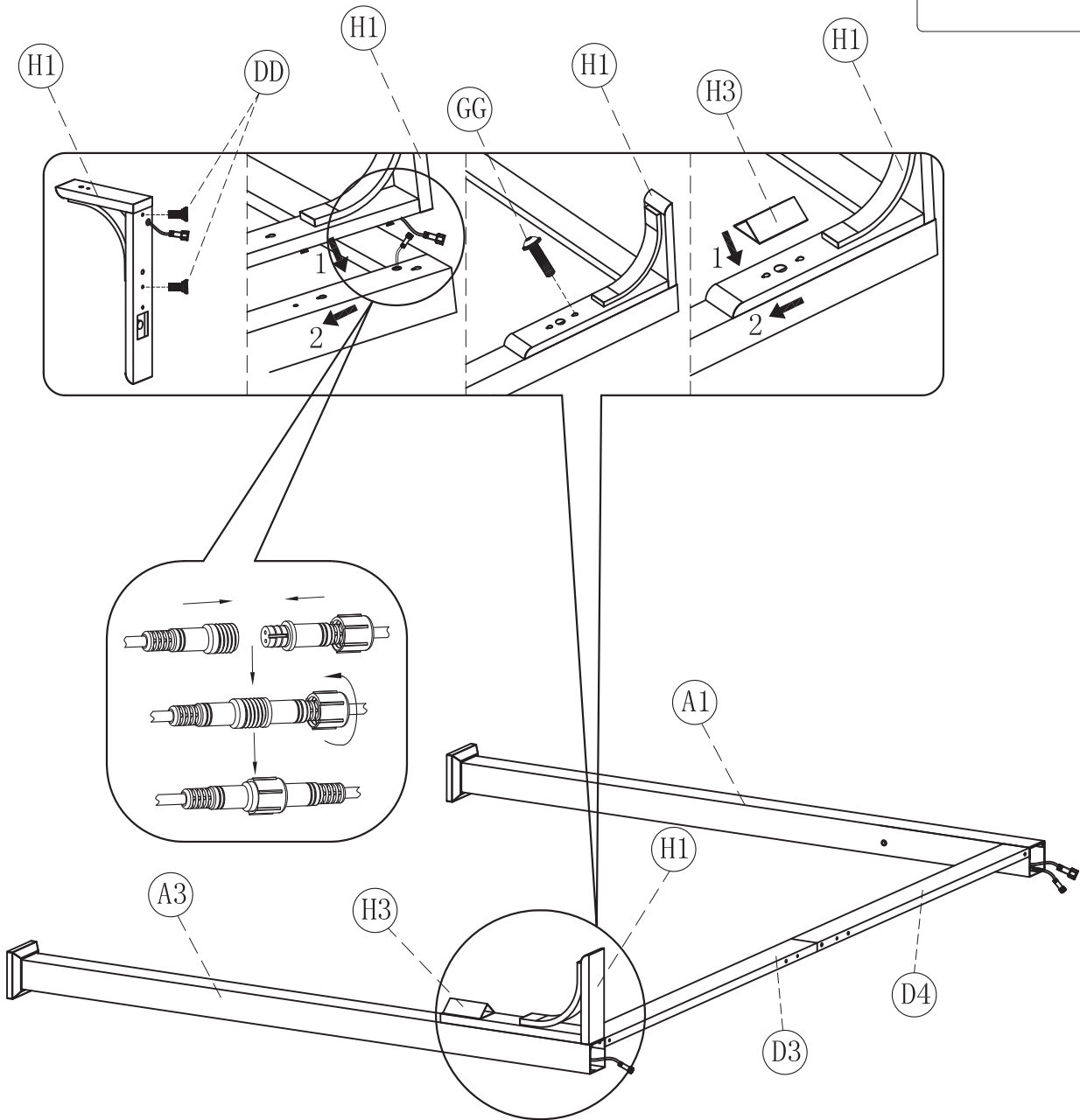
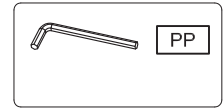
Step 9

1. Attach the Short beam (D3) & (D4) to the Post leg (A1) & (A3) with M8*25 Bolt with washer (AA).
2. Tighten all bolts by using Wrench (RR).



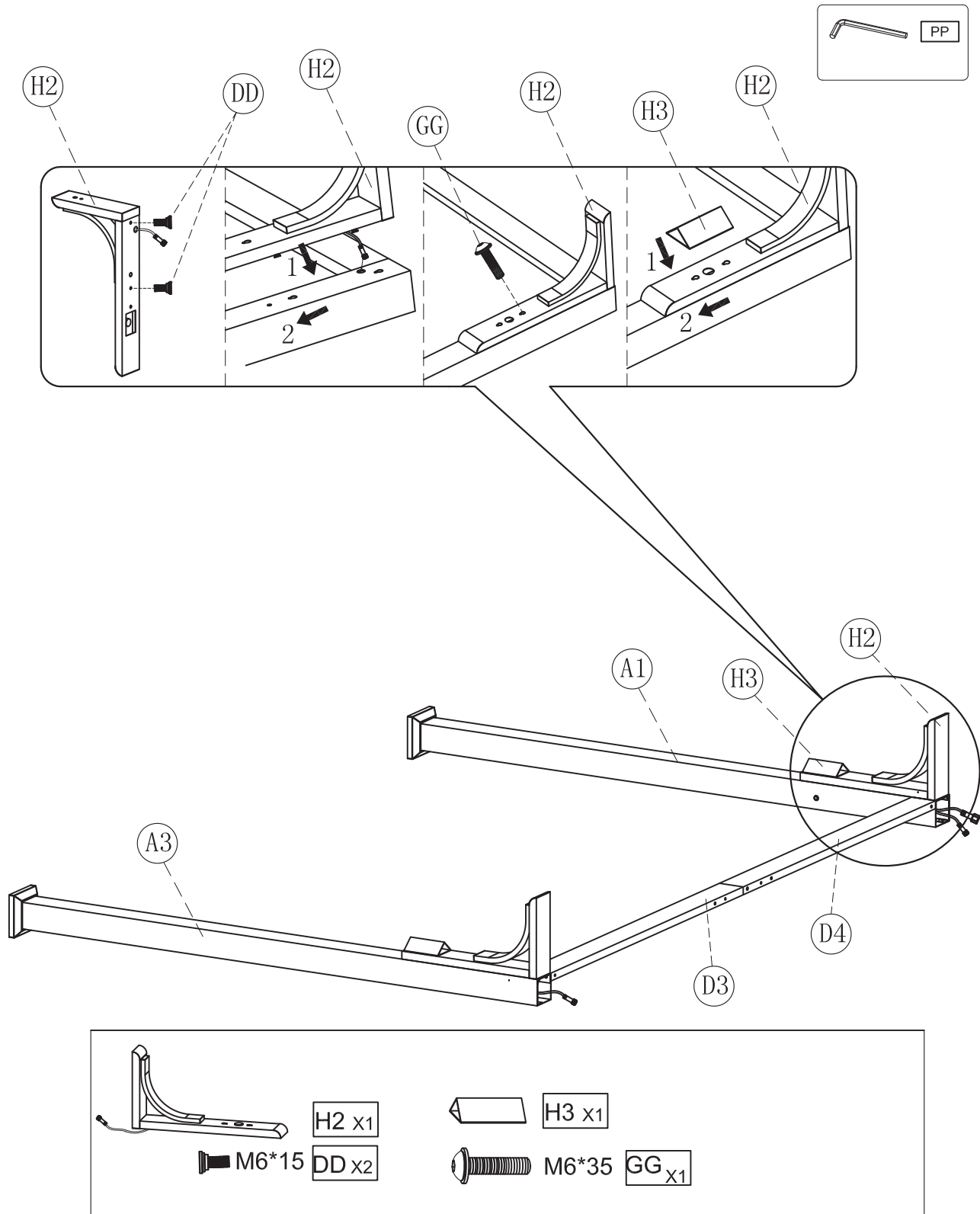
Step 10

1. Use the M6*15 bolt (DD) on the Corner connector (H1).
2. Connect the wires of Short beam (D3) & Corner connector (H1), then insert the wires into the Post leg (A3).
3. Insert the Corner connector (H1) into the Post leg (A3) with M6*35 bolt with washer (GG).
4. Tighten all bolts by using Allen wrench (PP).
5. Insert the Downlight (H3) into the Corner connector (H1).



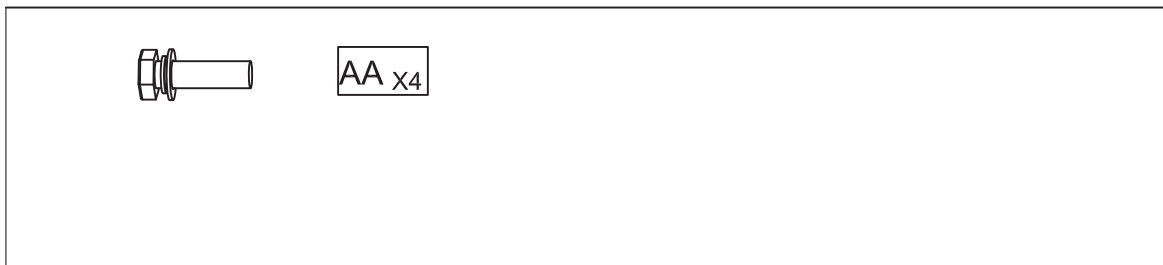
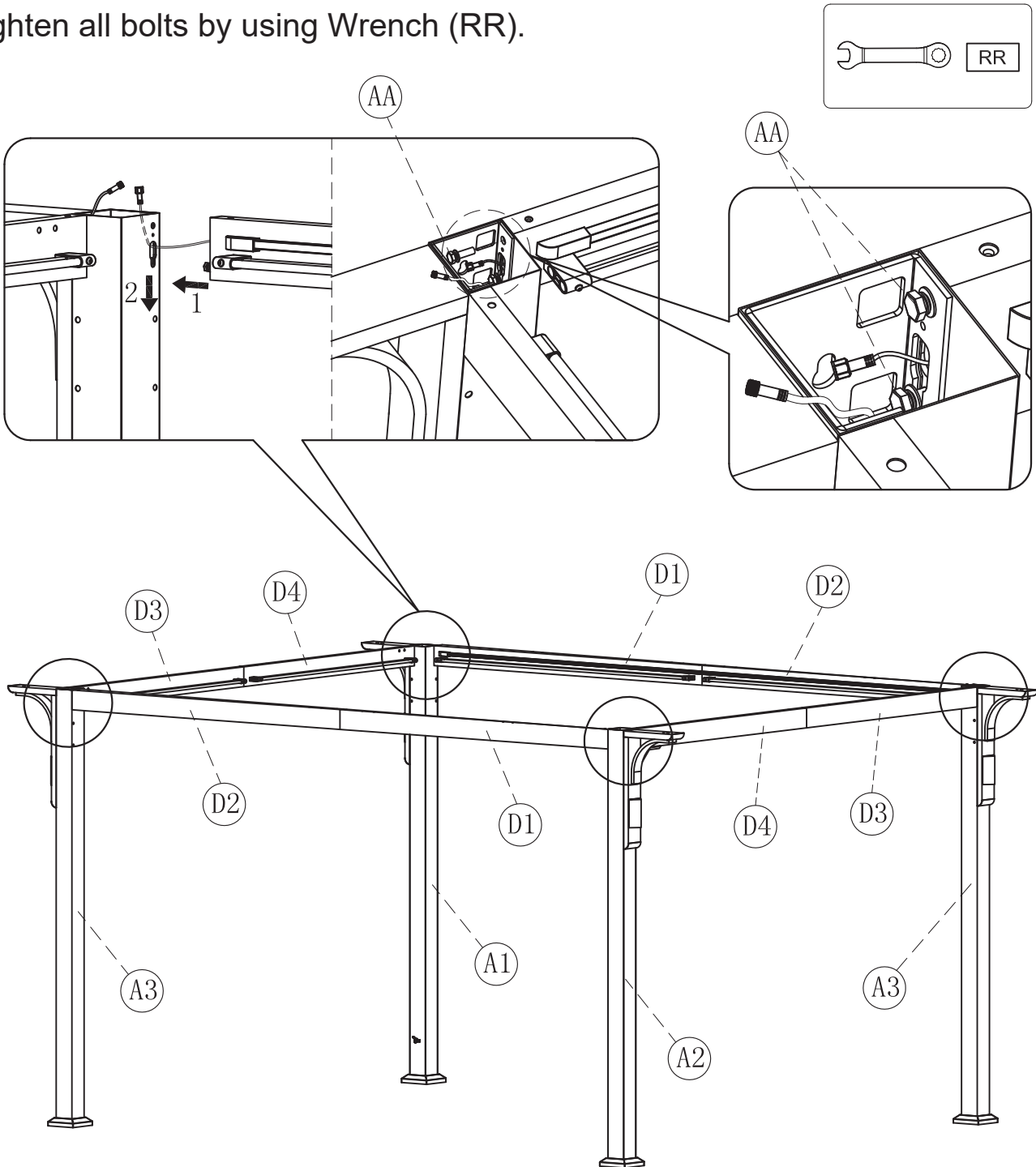
Step 11

1. Use the M6*15 bolt (DD) on the Corner connector (H2).
2. Attach the Corner connector (H2) to the Post leg (A1) with M6*35 bolt with washer (GG).
3. Tighten all bolts by using Allen wrench (PP).
4. Insert the Downlight (H3) into the Corner connector (H2).



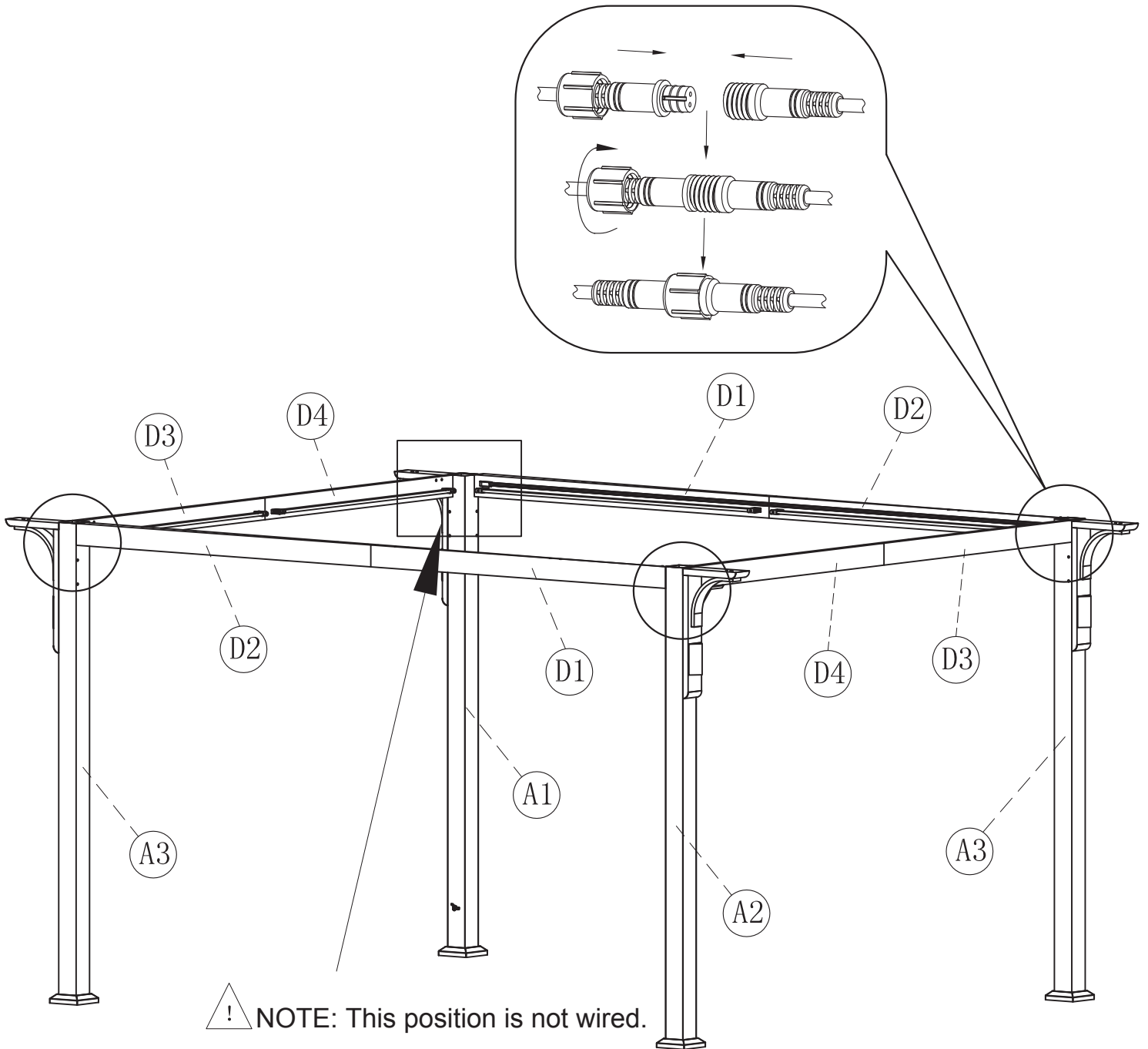
Step 12

1. Insert the Long beam (D1) & (D2) into the Post leg (A1) with M8*25 bolt with washer (AA).
2. Repeat this step for all post leg (A2) & (A3).
3. Tighten all bolts by using Wrench (RR).



Step 13

1. Connect the wires on the post leg (A3) & (A2).



Step 14

IMPORTANT

Squaring the gazebo frame is a very important step to ensure easier assembly and proper fitment of parts. To do this, measure the distance between the legs from the outside corners of each leg post in the following order:

A to B

C to D

These measurements should be the same. Adjust legs if they are not.

A to C

B to D

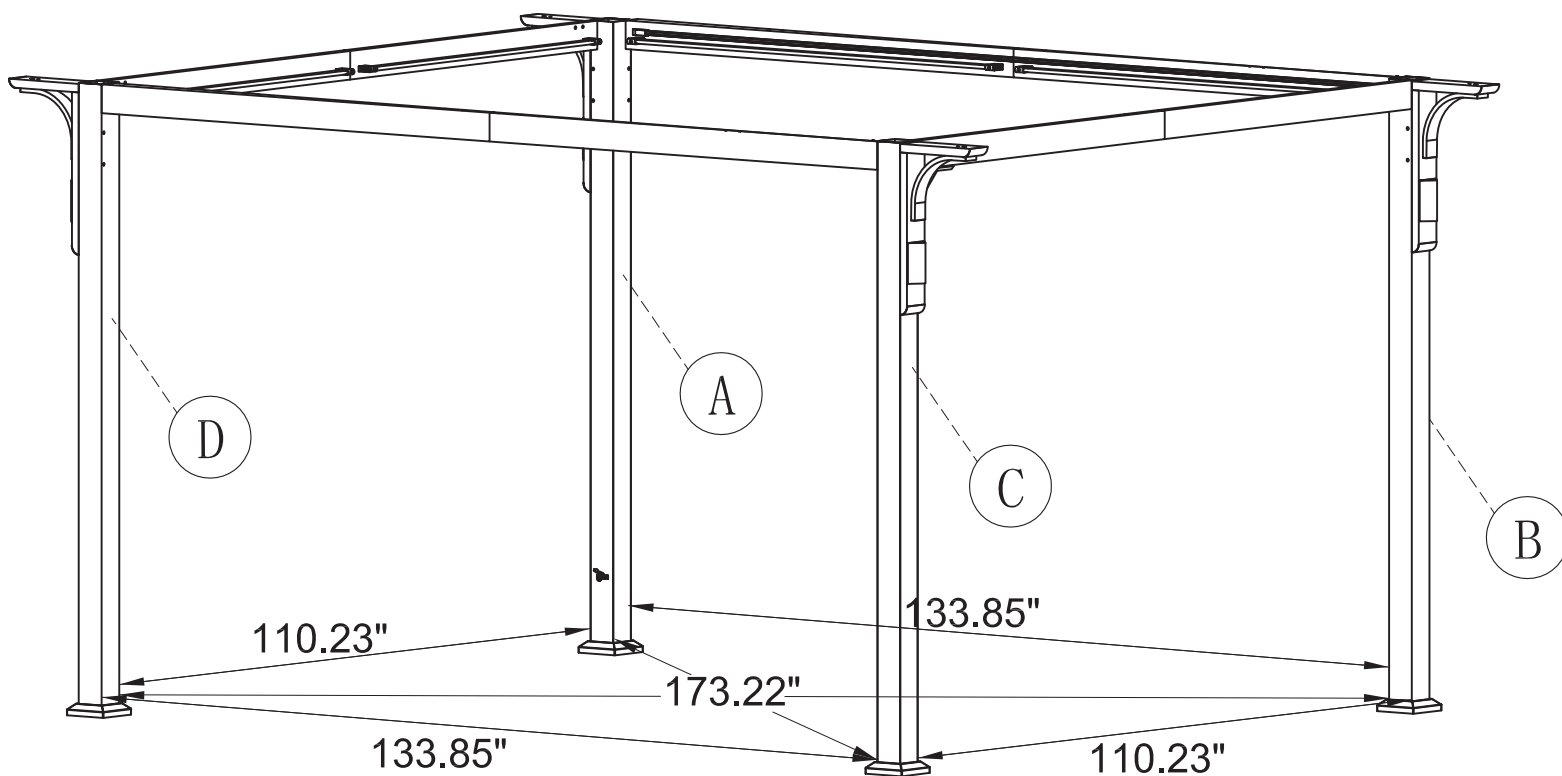
These measurements should be the same. Adjust legs if they are not.

A to D

B to C

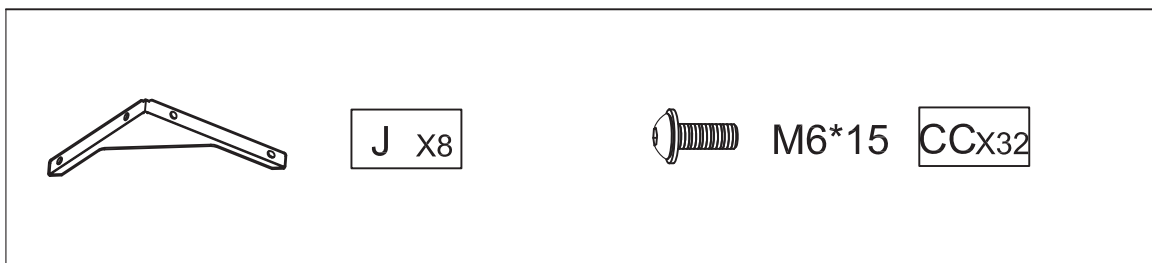
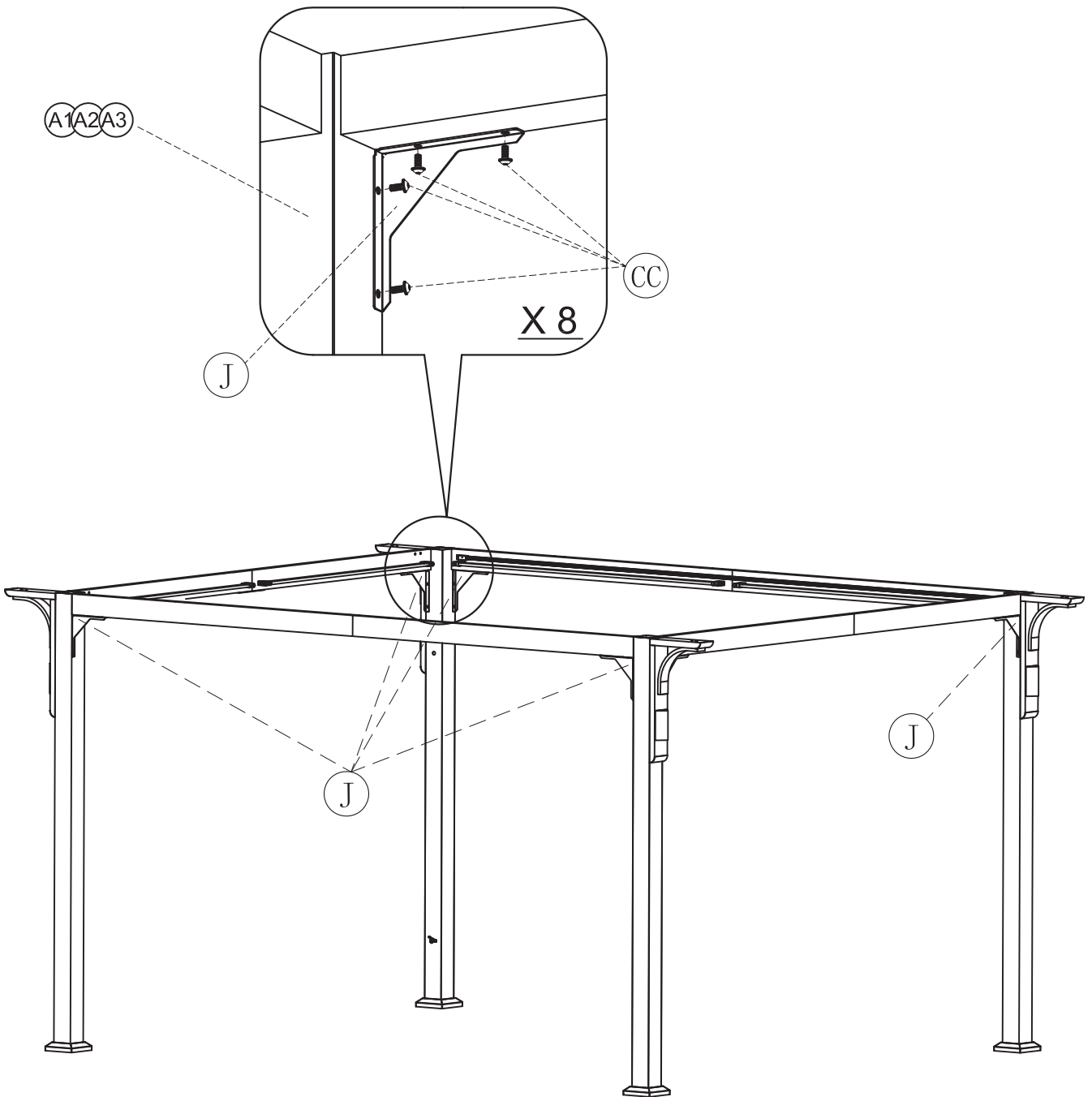
These measurements should be the same. Adjust legs if they are not.

Once the measurements above are approximately the same, then move on to Step 15.



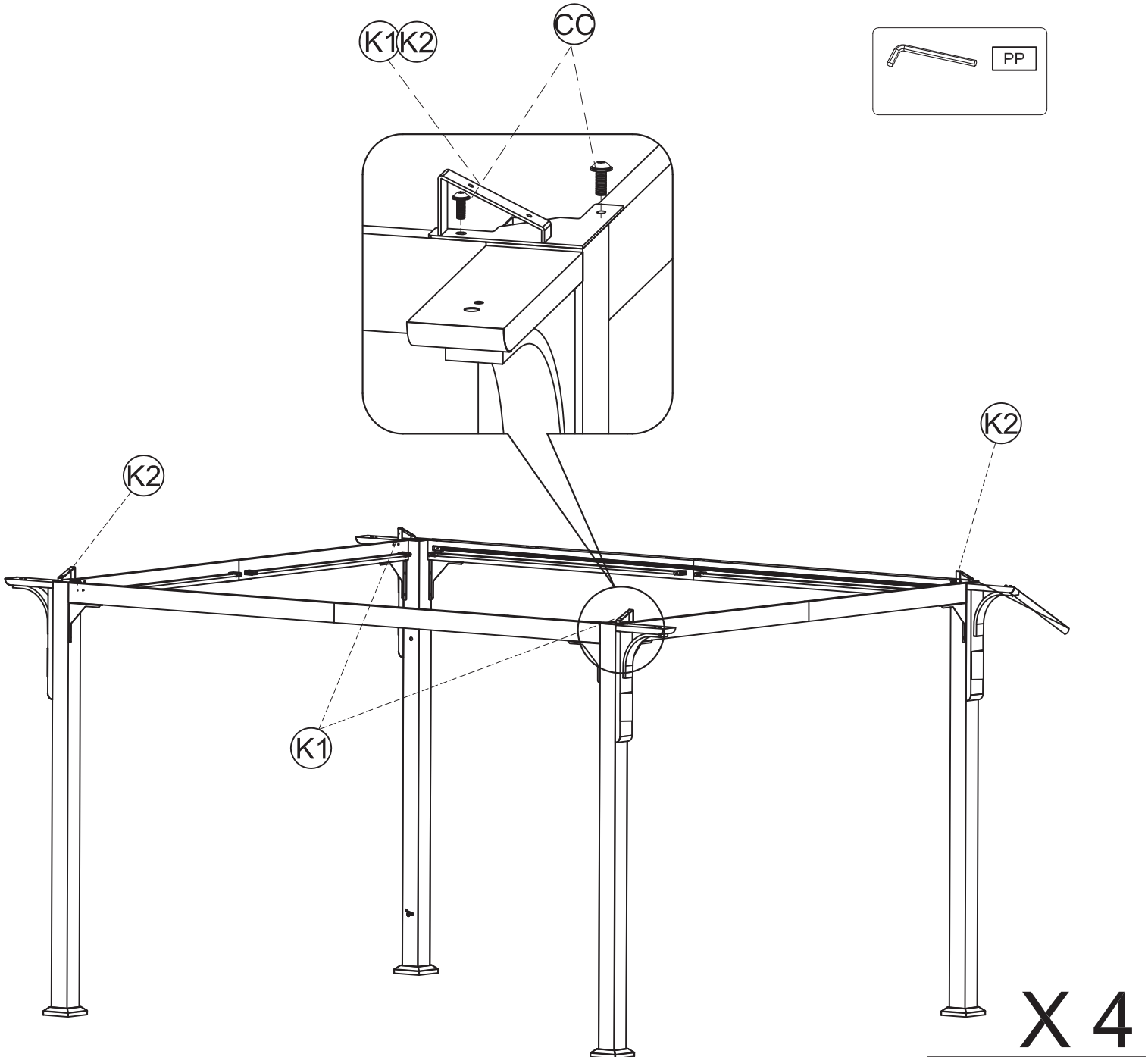
Step 15

1. Attach the Gable support (J) to the Post leg (A1) with M6*15 bolt with washer (CC).
2. Tighten all bolts by using Allen wrench (PP). Repeat this step for the remaining Gable support (J).



Step 16

1. Attach the Top of post leg plates (K1) & (K2) to the Post leg with M6*15 bolt with washer (CC).
2. Tighten all bolts by using Allen wrench (PP).



K1 x2



K2 x2



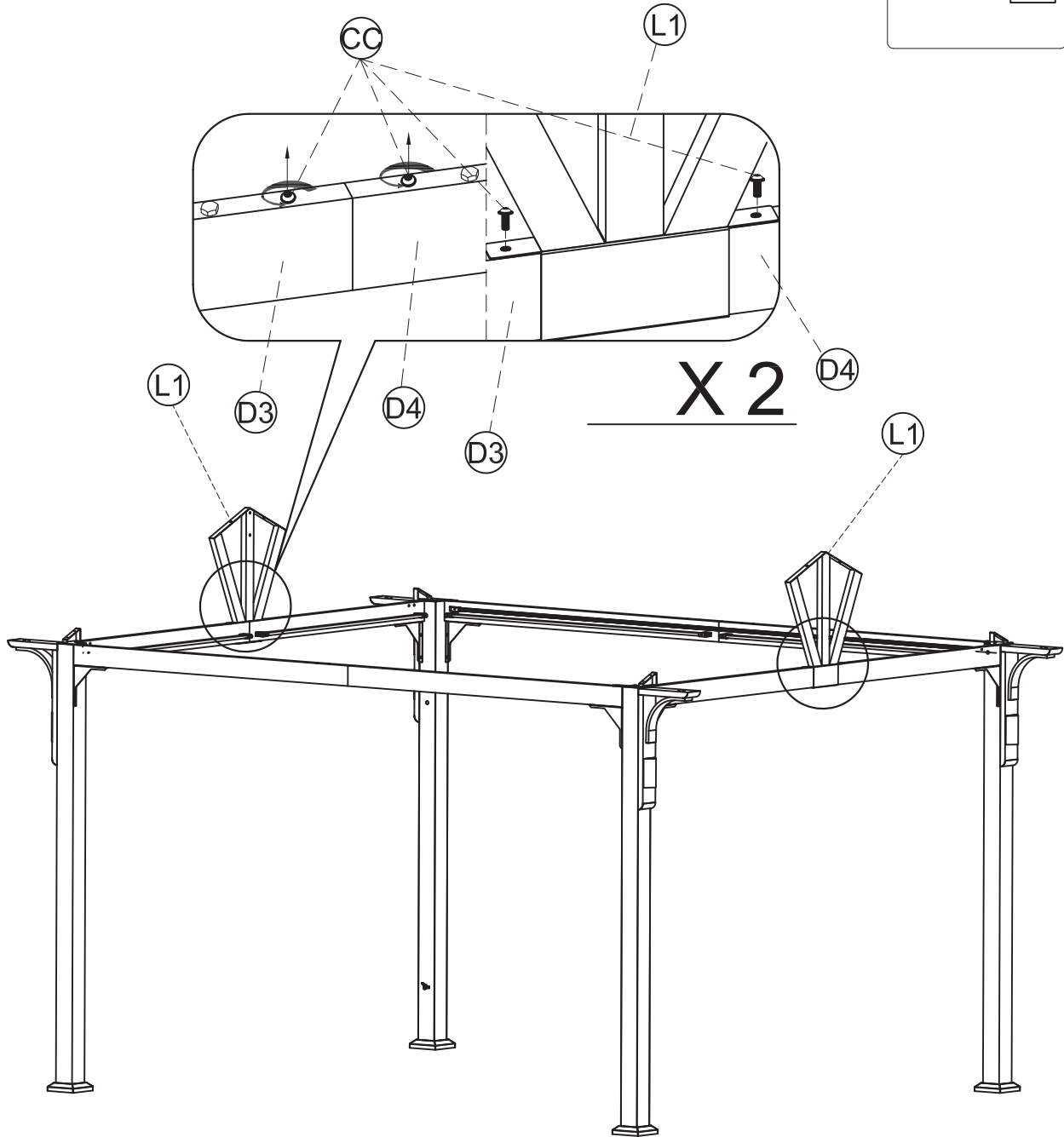
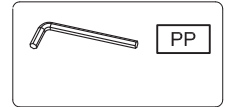
M6*15

CC x8

X 4

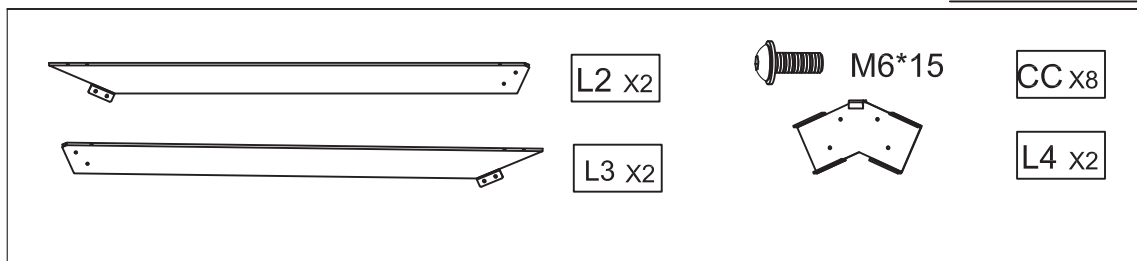
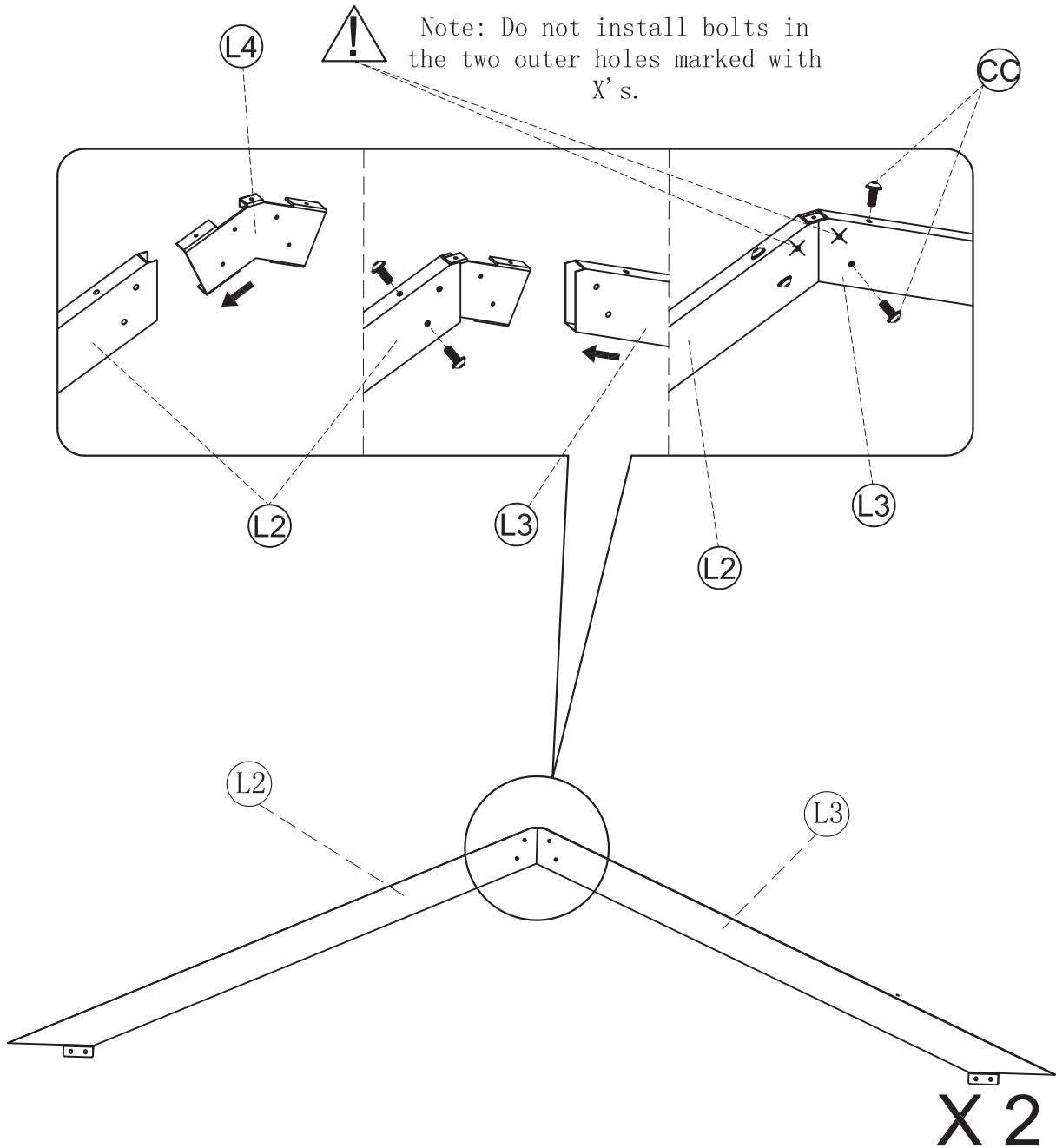
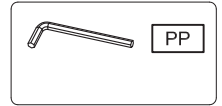
Step 17

1. Remove the M6*15 bolt with washer (CC) from the Short beam (D3) & (D4).
2. Attach the Gable (L1) to the Short beam (D3) & (D4) with M6*15 bolt with washer (CC).
3. Tighten all bolts by using Allen wrench (PP).



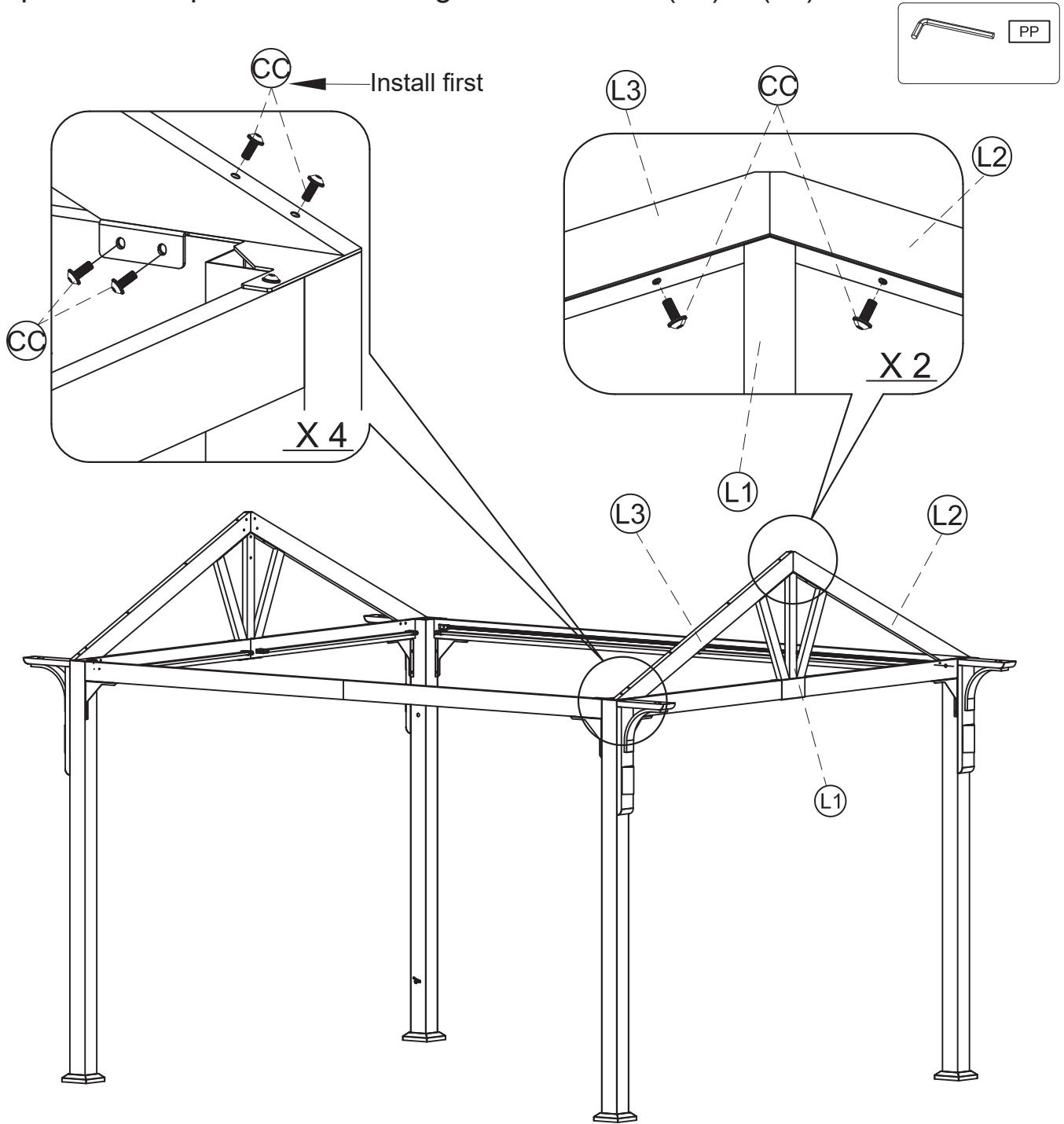
Step 18

1. Insert the Inclined beam connector (L4) into the Inclined beam (L2) with M6 * 15 bolt with washer (CC)
2. Insert the Inclined beam (L3) into the Inclined beam (L2) with M6 * 15 bolt with washer (CC).
3. Tighten all bolts by using Allen wrench (PP).
4. Repeat this step for the remaining Inclined beam (L2) & (L3).



Step 19

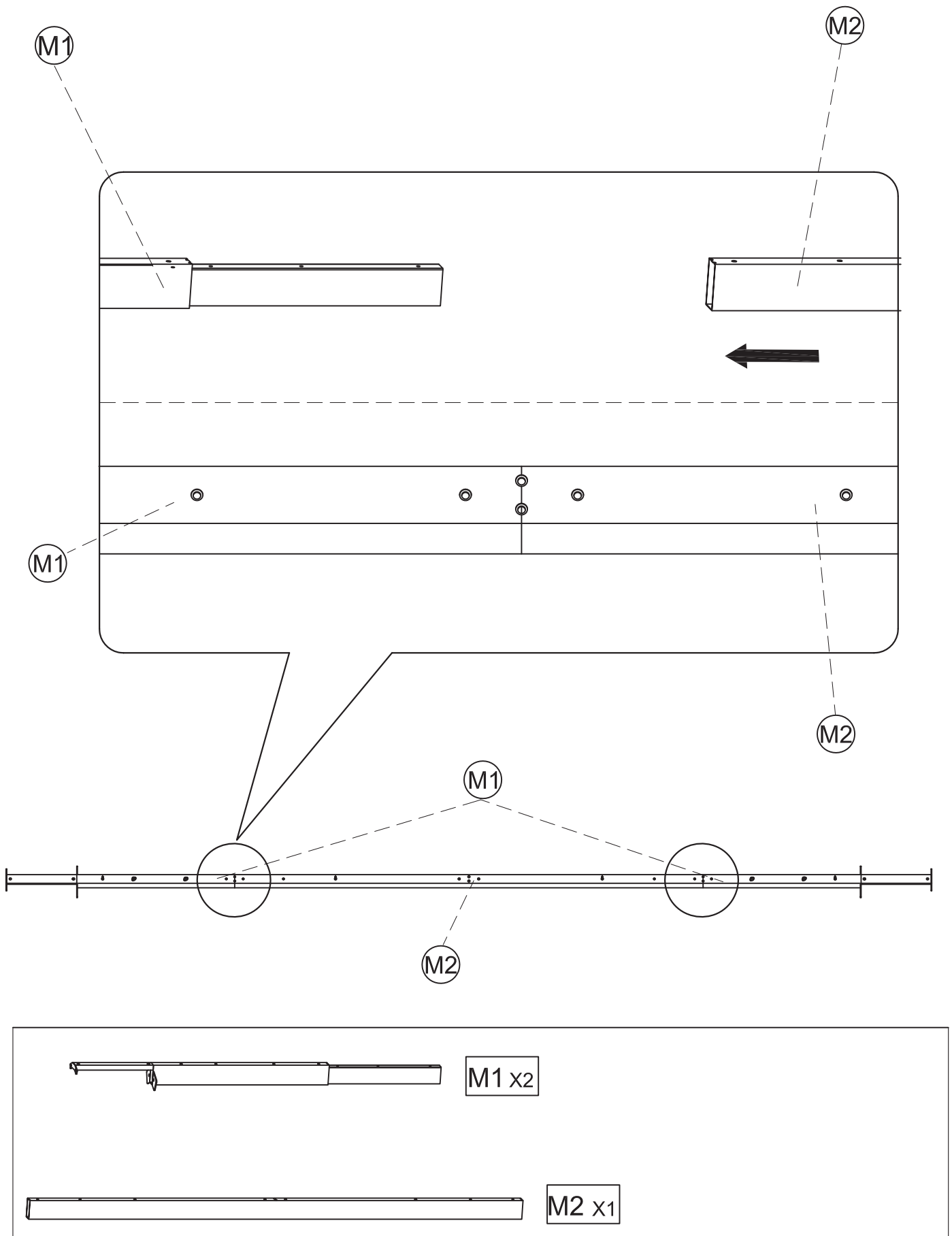
1. Attach the Inclined beam (L2) & (L3) to the Gabel (L1) and Short beam with M6*15 bolt with washer (CC).
2. Tighten all bolts by using Allen wrench (PP).
3. Repeat this step for the remaining Inclined beam (L2) & (L3).



 M6*15 CCx20

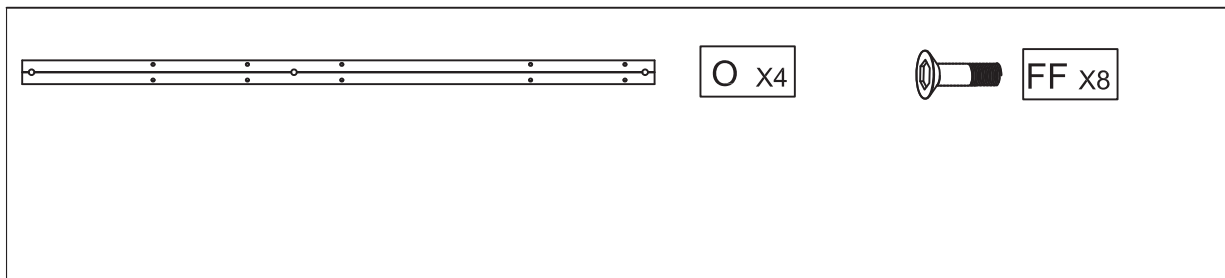
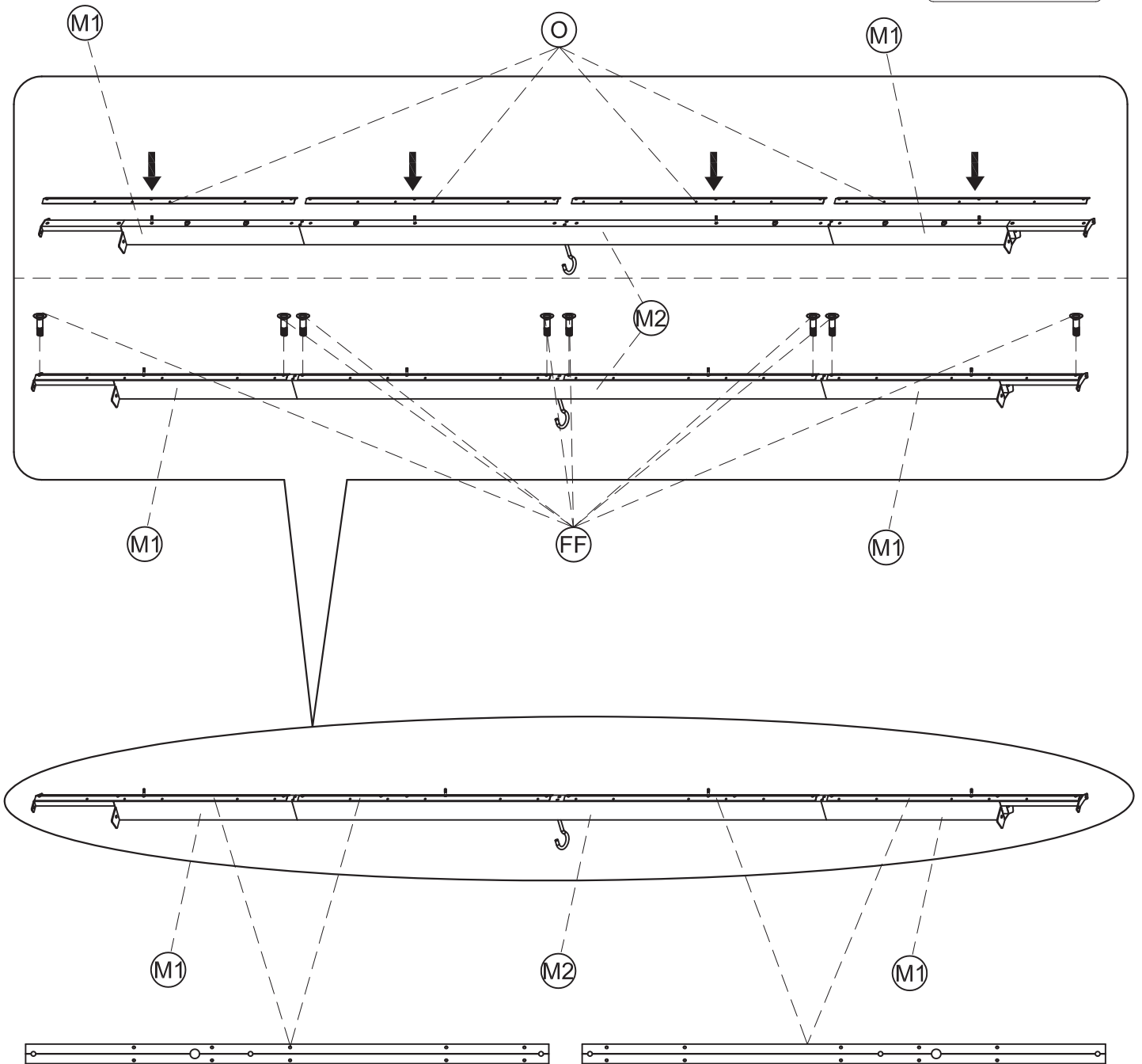
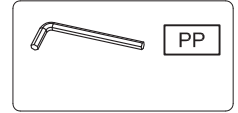
Step 20

1. Insert the two Top beam (M1) into the Top beam (M2).



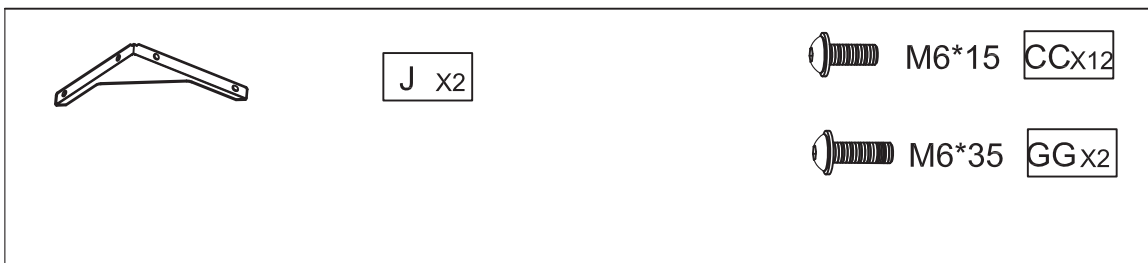
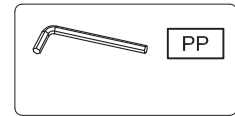
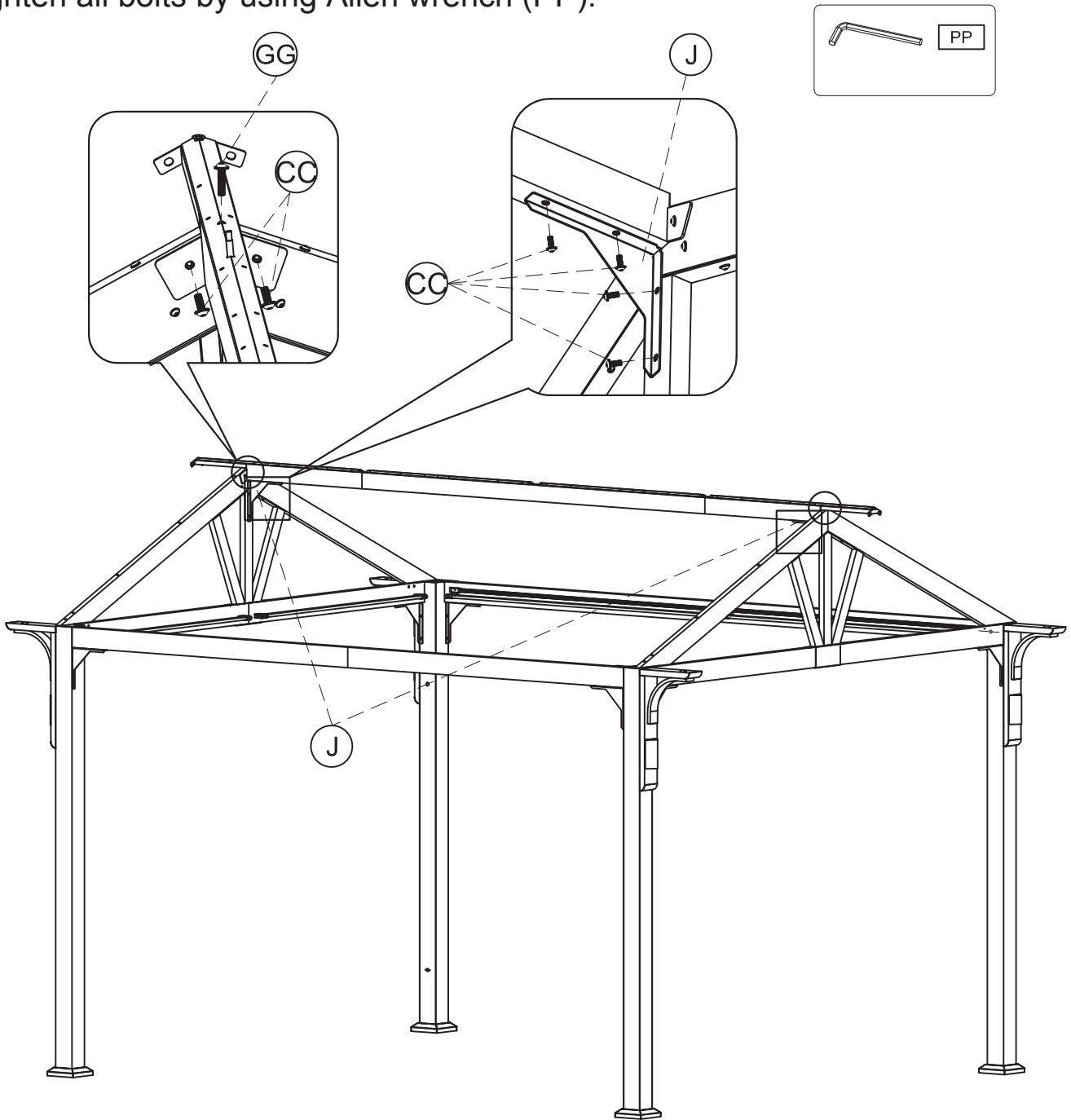
Step 22

1. Insert the Roof connector (O) into the Top beam (M1) & (M2) with M6*20 Bolt (FF).
2. Tighten all bolts by using Allen wrench (PP).



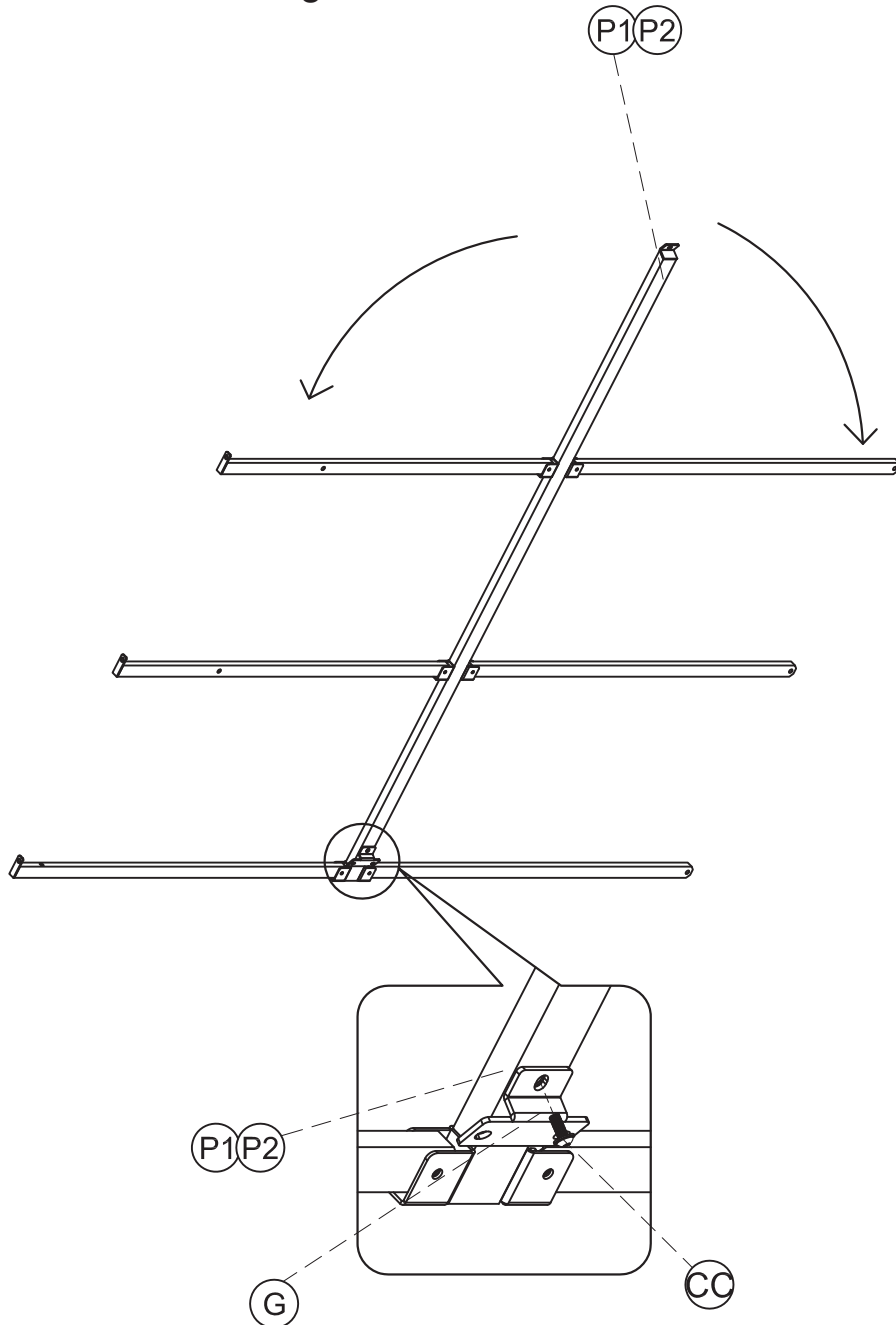
Step 23

1. Attach the Top beam (M1) & (M2) to the Inclined beam (L2) & (L3) with M6*15 bolt with washer (CC) & M6*35 bolt with washer (GG).
2. Attach the Gable support (J) to the Top beam (M1) & Gable (L1) with M6*15 bolt with washer (CC).
3. Tighten all bolts by using Allen wrench (PP).

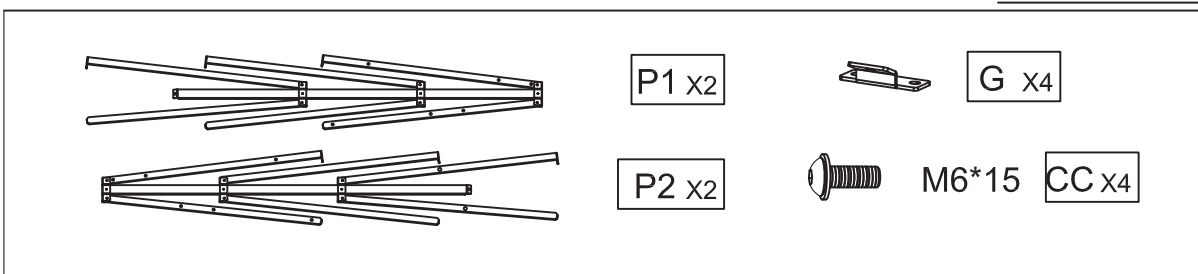


Step 24

1. Spread the Rafter branch unit (P1) & (P2) to both sides.
2. Attach the Middle inclined beam connector (G) to the Rafter branch unit (P1) & (P2) with M6*15 bolt with washer (CC).
3. Tighten all bolts by using Allen wrench (PP).
4. Repeat this step for the remaining Middle inclined beam connector (G).

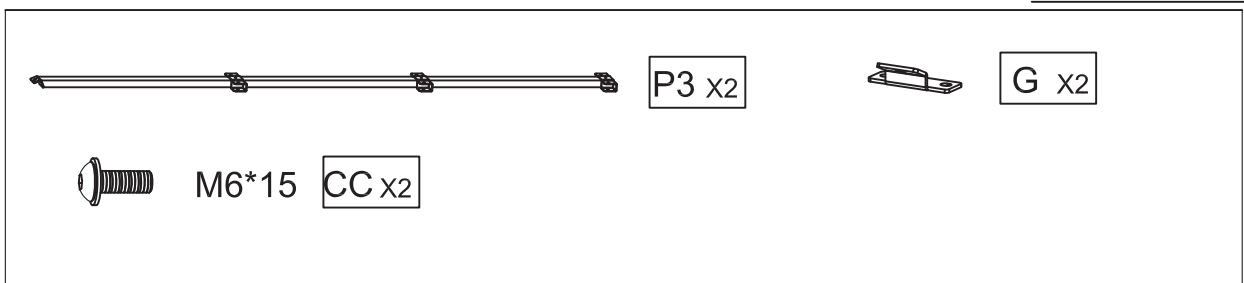
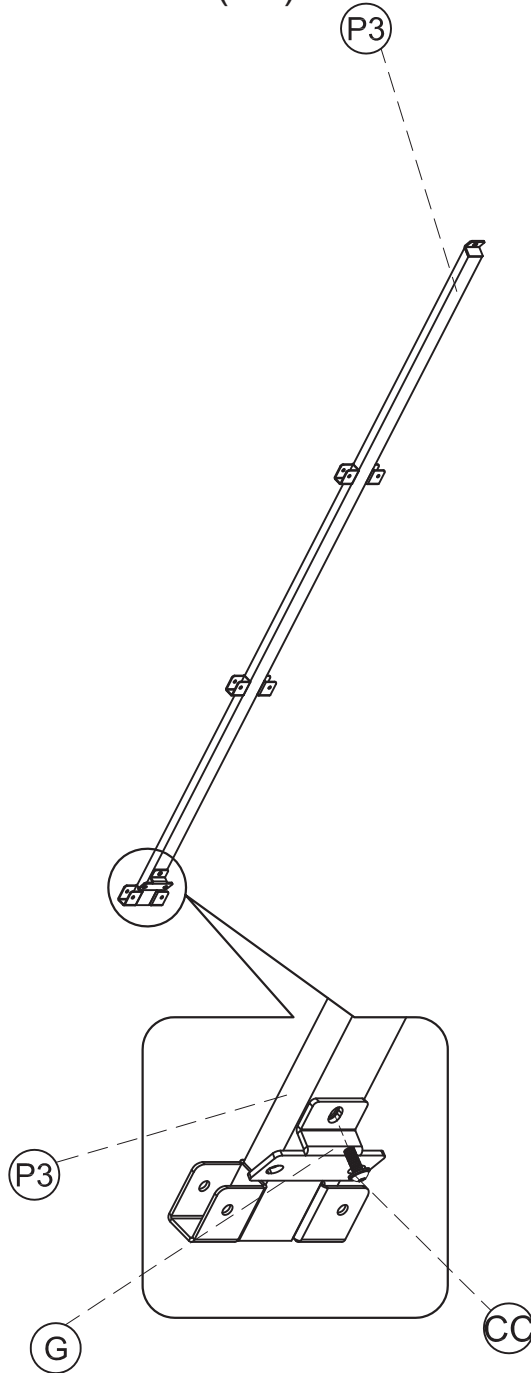


X 4



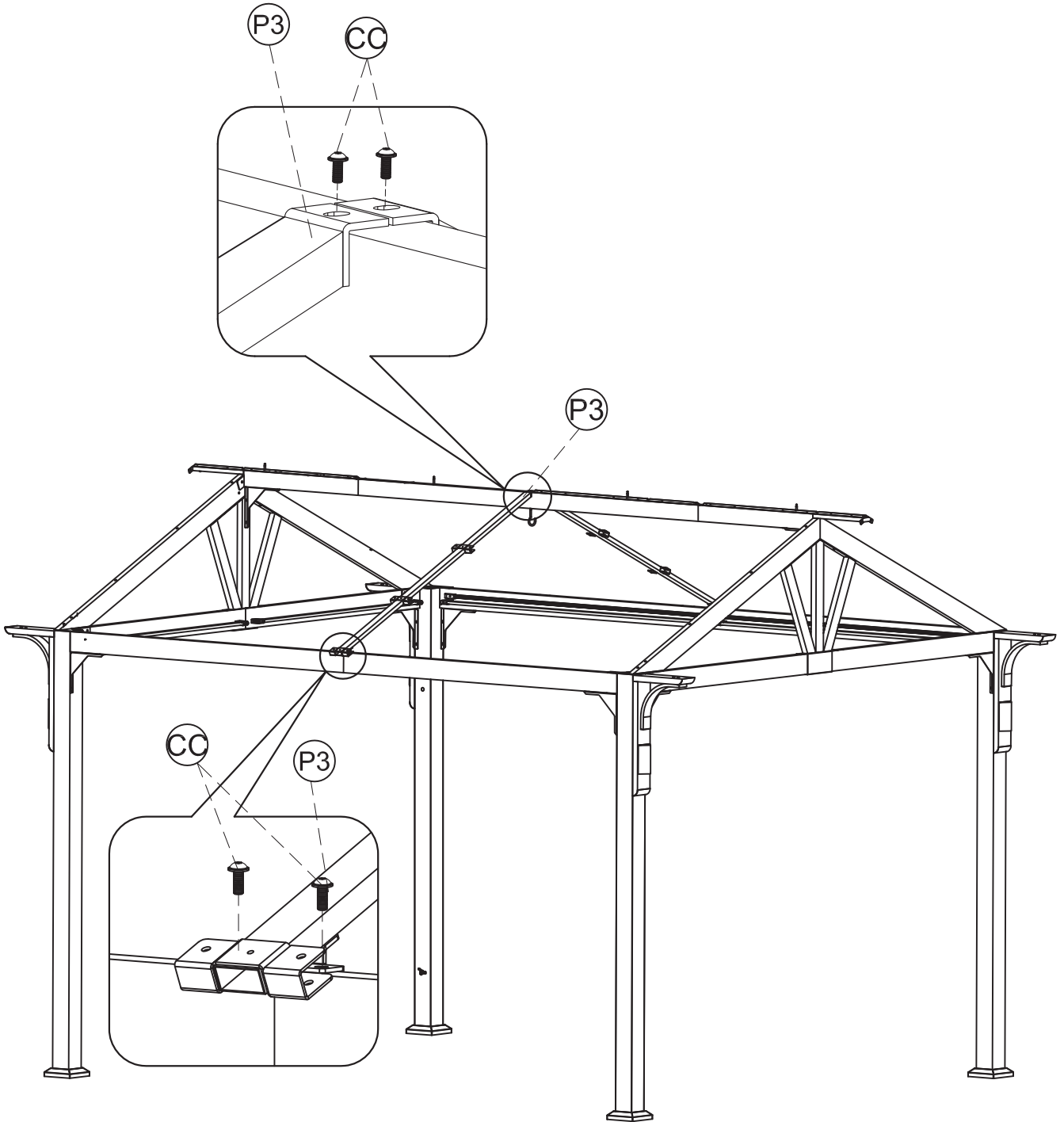
Step 25


1. Attach the Middle inclined beam connector (G) to the Rafter branch unit (P3) with M6*15 bolt with washer (CC).
2. Repeat this step for the remaining Middle incline beam connector (G).
3. Tighten all bolts by using Allen wrench (PP).



Step 26

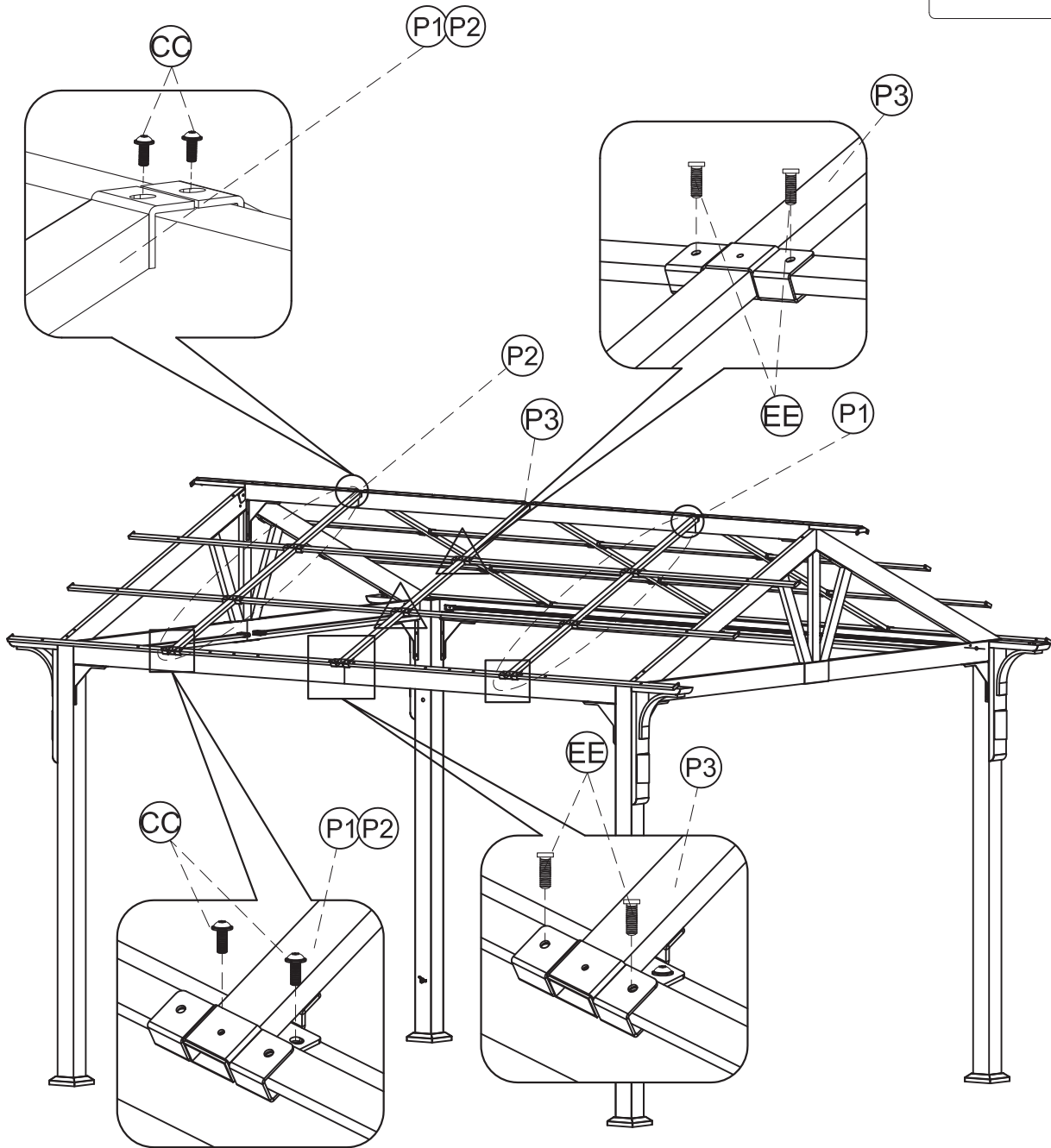
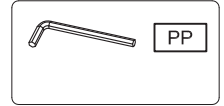
1. Attach the Rafter branch unit (P3) to the Long beam (D1) & (D2) with M6*15 bolt with washer (CC).
2. Tighten all bolts by using Allen wrench (PP).





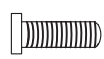

 M6*15 CC x4

Step 27

1. Attach the Rafter branch unit (P1) & (P2) to the Top beam (M1) & (M2) with M6*15 bolt with washer (CC).
2. Use the M6*10 bolt (EE) to connect the Rafter branch unit (P1) & (P2) to the Rafter branch unit (P3).
3. Tighten all bolts by using Allen wrench (PP).

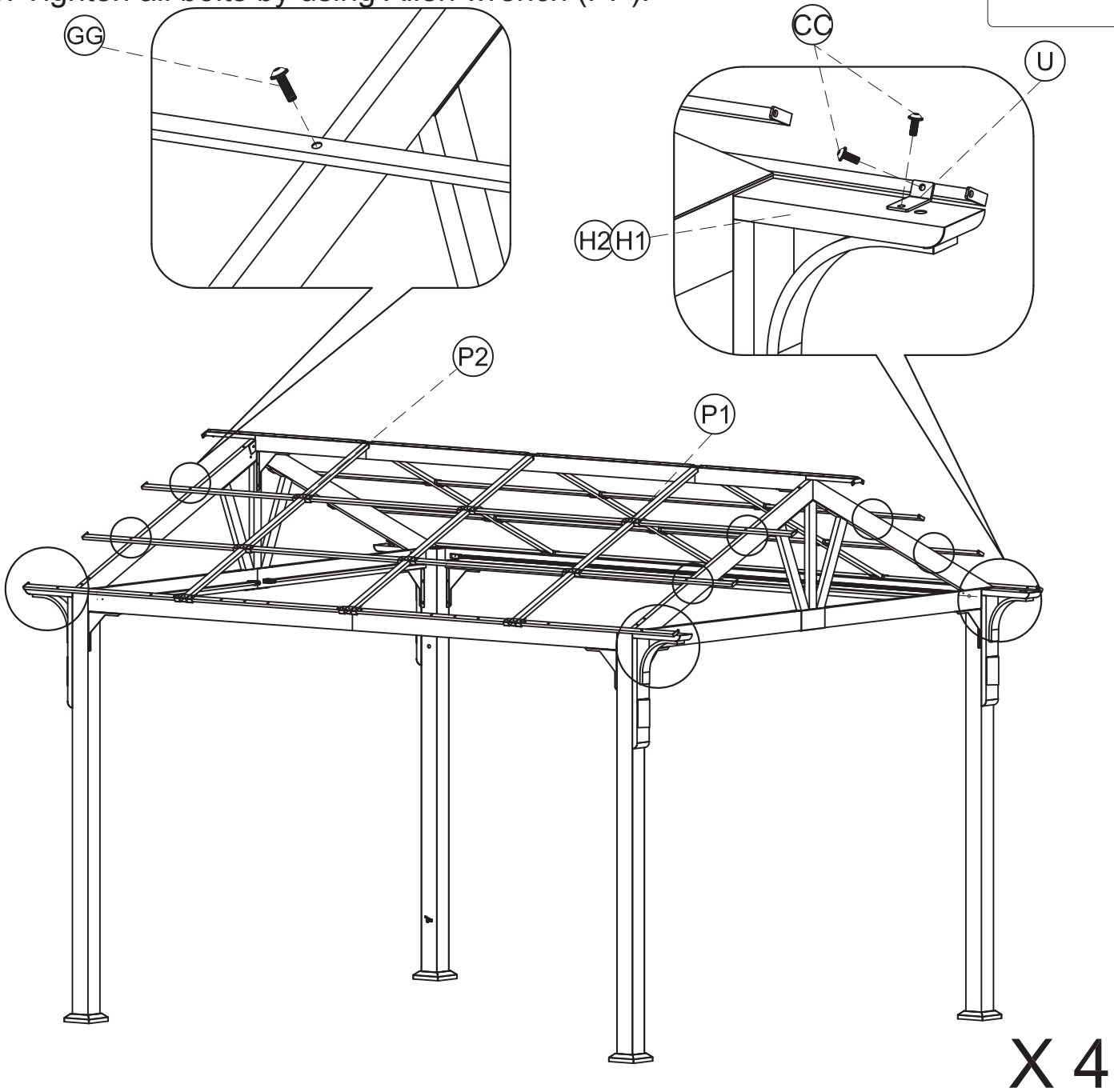


 M6*15 

 M6*10 

Step 28

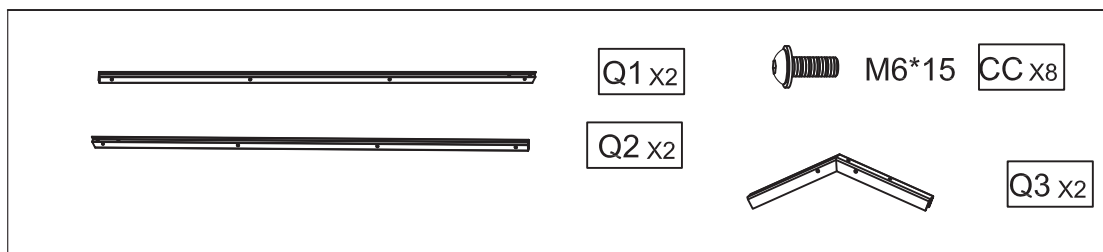
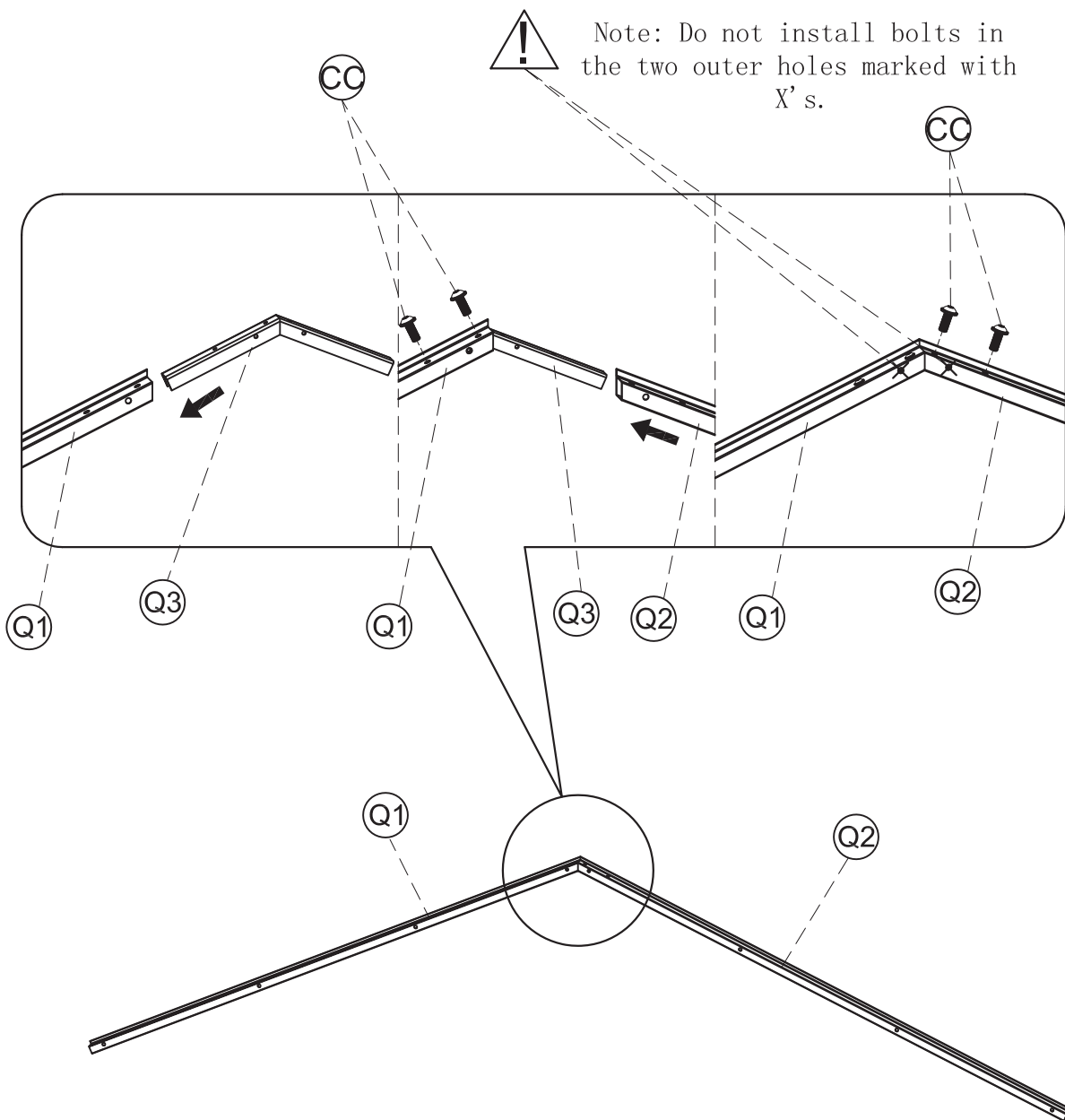
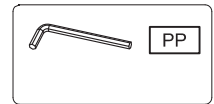
1. Use the M6*35 bolt with washer (GG) to connect the Inclined beam (L2) & (L3) and Rafter branch unit (P1) & (P2).
2. Attach the Corbel connector (U) to the Corner connector (H1) & (H2) and Rafter branch unit (P1) & (P2) with M6*15 bolt with washer (CC).
3. Tighten all bolts by using Allen wrench (PP).



	U X4		M6*15 CC X8
			M6*35 GG X8

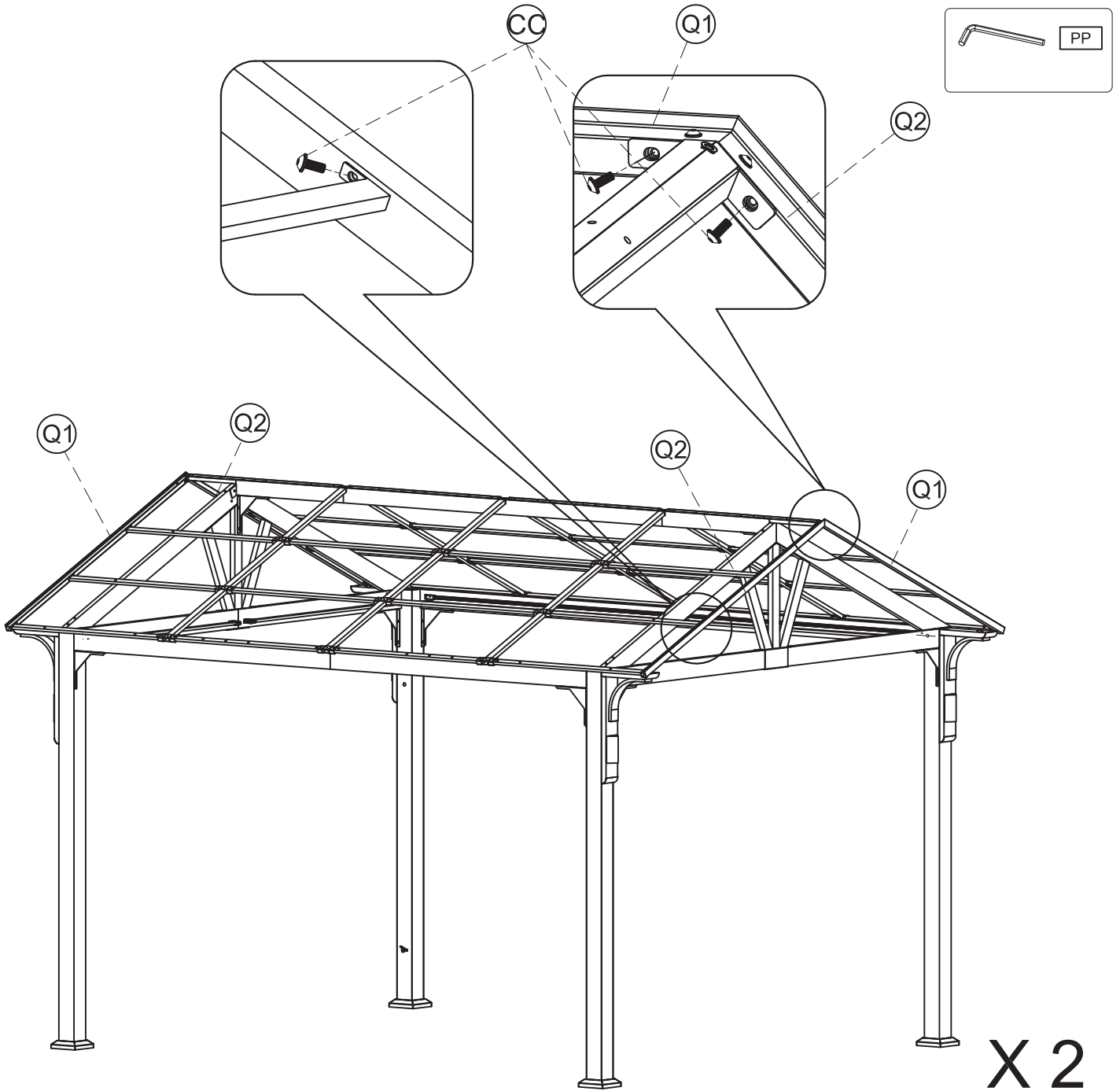
Step 29

1. Insert the Cross beam connector (Q3) into the Cross beam (Q1).
2. Insert the Cross beam (Q2) into the Cross beam connector (Q3).
3. Use the M6*15 bolt with washer (CC) to connect the Cross beam (Q2) & (Q1).
4. Tighten all bolts by using Allen wrench (PP).
5. Repeat this step for the remaining Cross beam (Q2) & (Q1).



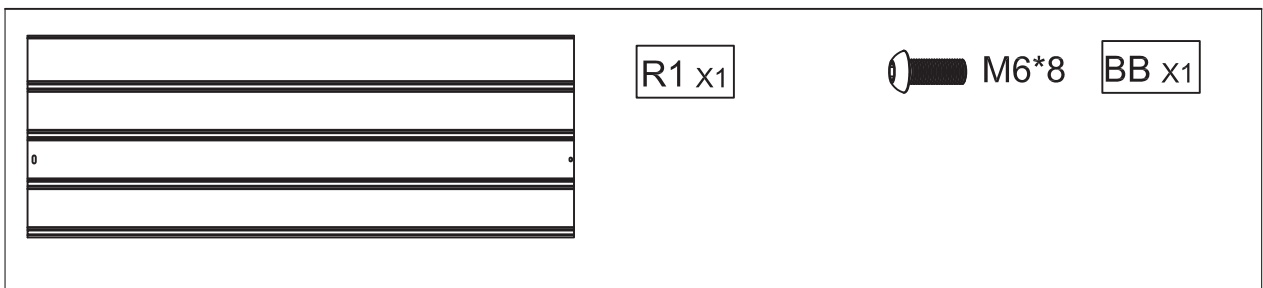
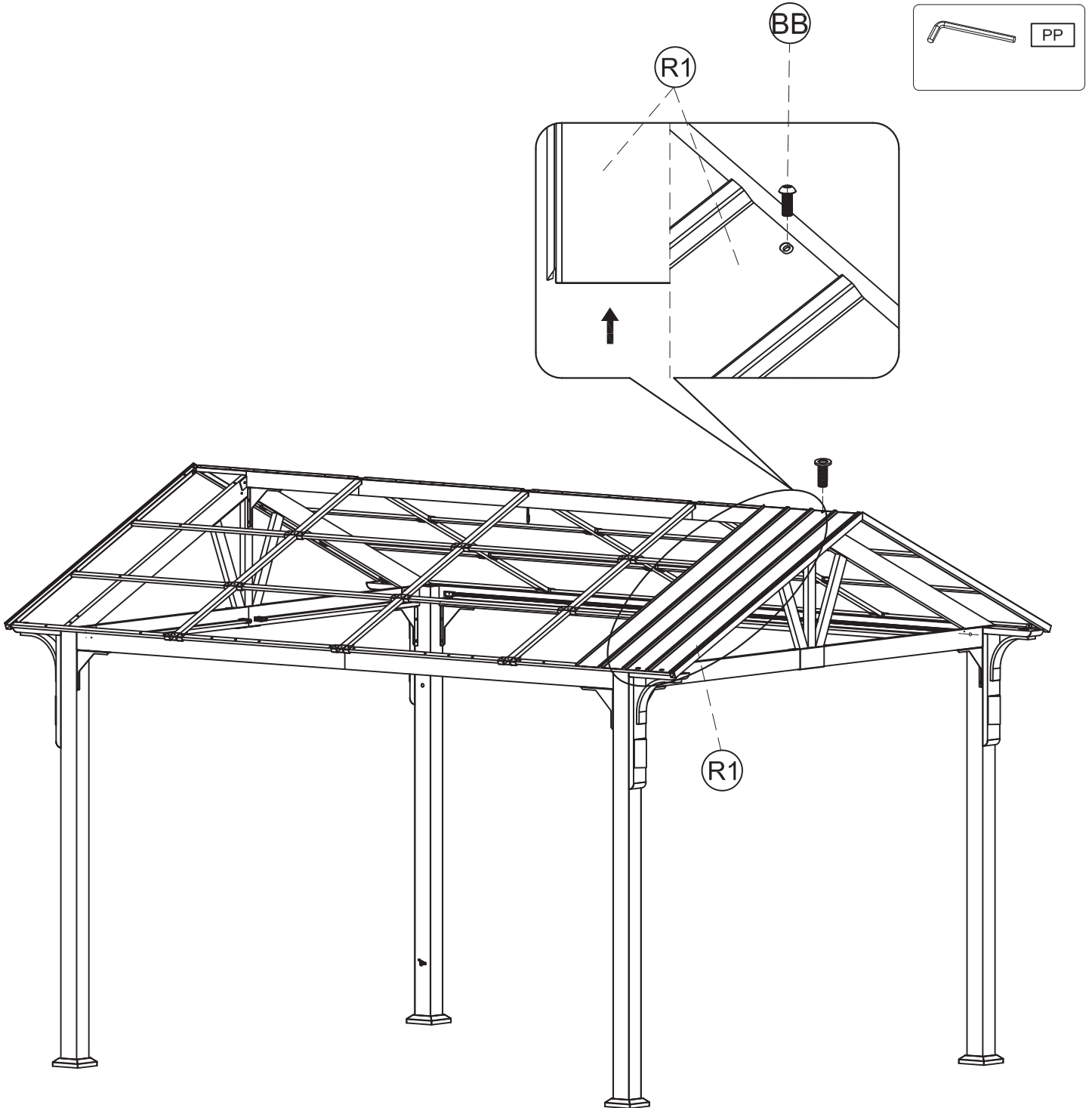
Step 30

1. Attach the Cross beam (Q2) & (Q1) to the Rafter branch unit (P1) & (P2) & Top beam (M1) with M6*15 bolt with washer (CC).
2. Tighten all bolts by using Allen wrench (PP).
3. Repeat this step for the remaining Cross beam (Q2) & (Q1).



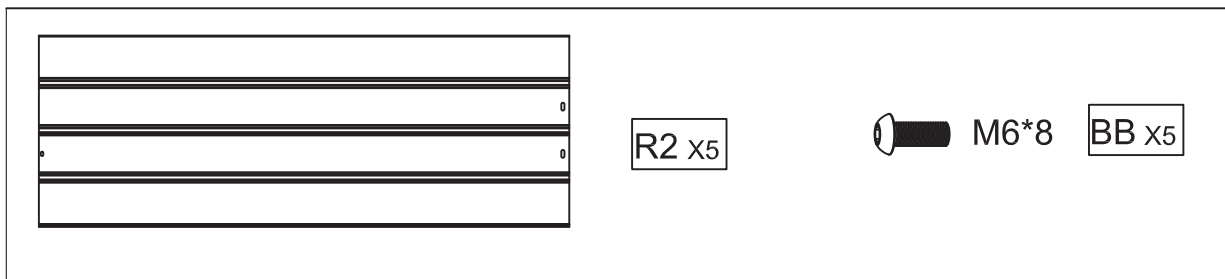
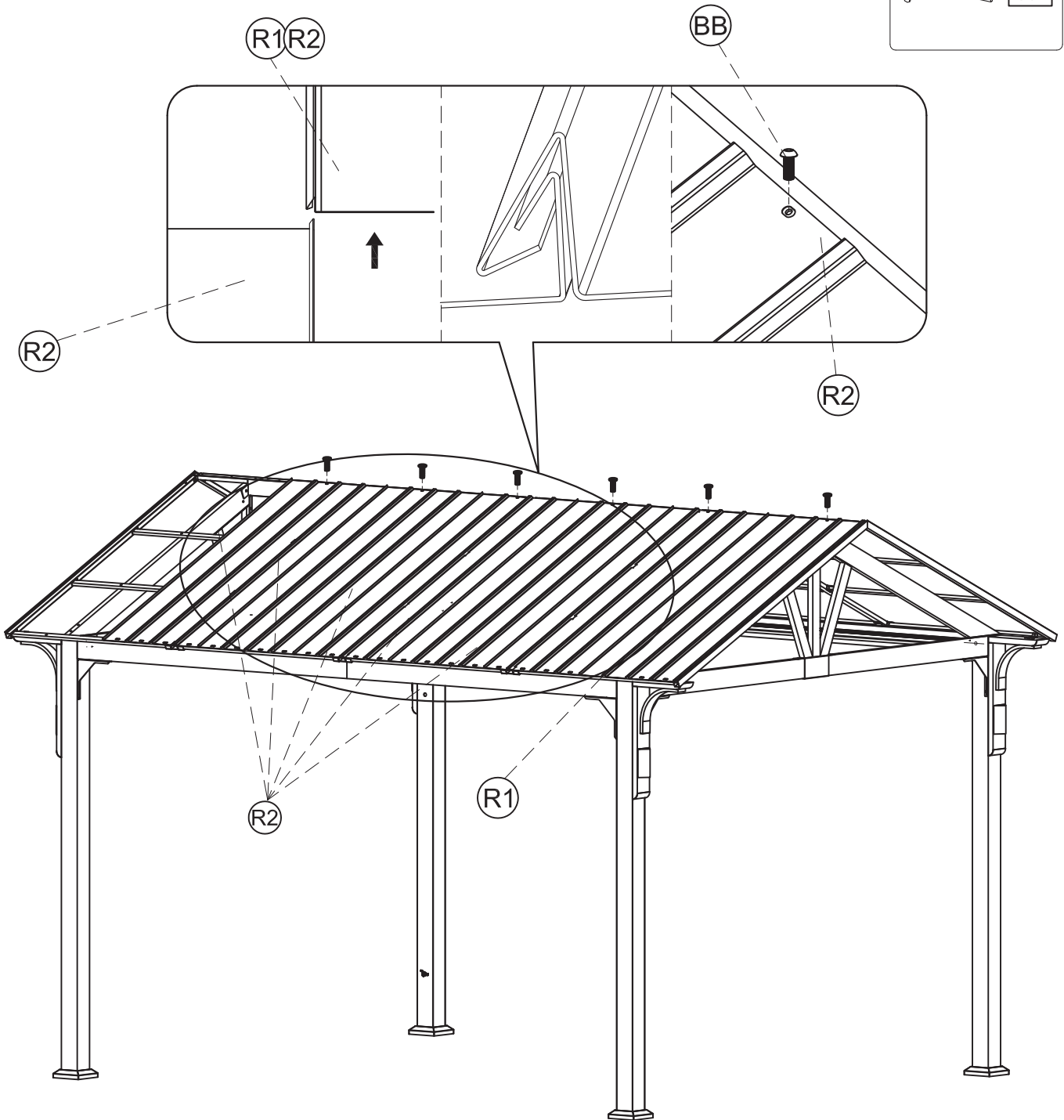
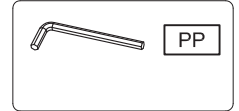
Step 31

1. Attach the Roof panel (R1) to the Roof connector (o) with M6*8 bolt (BB).
2. Tighten all bolts by using Allen wrench (PP).



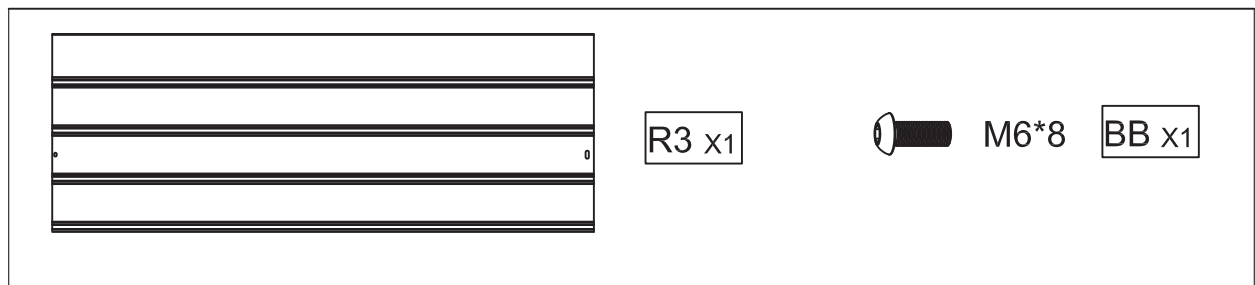
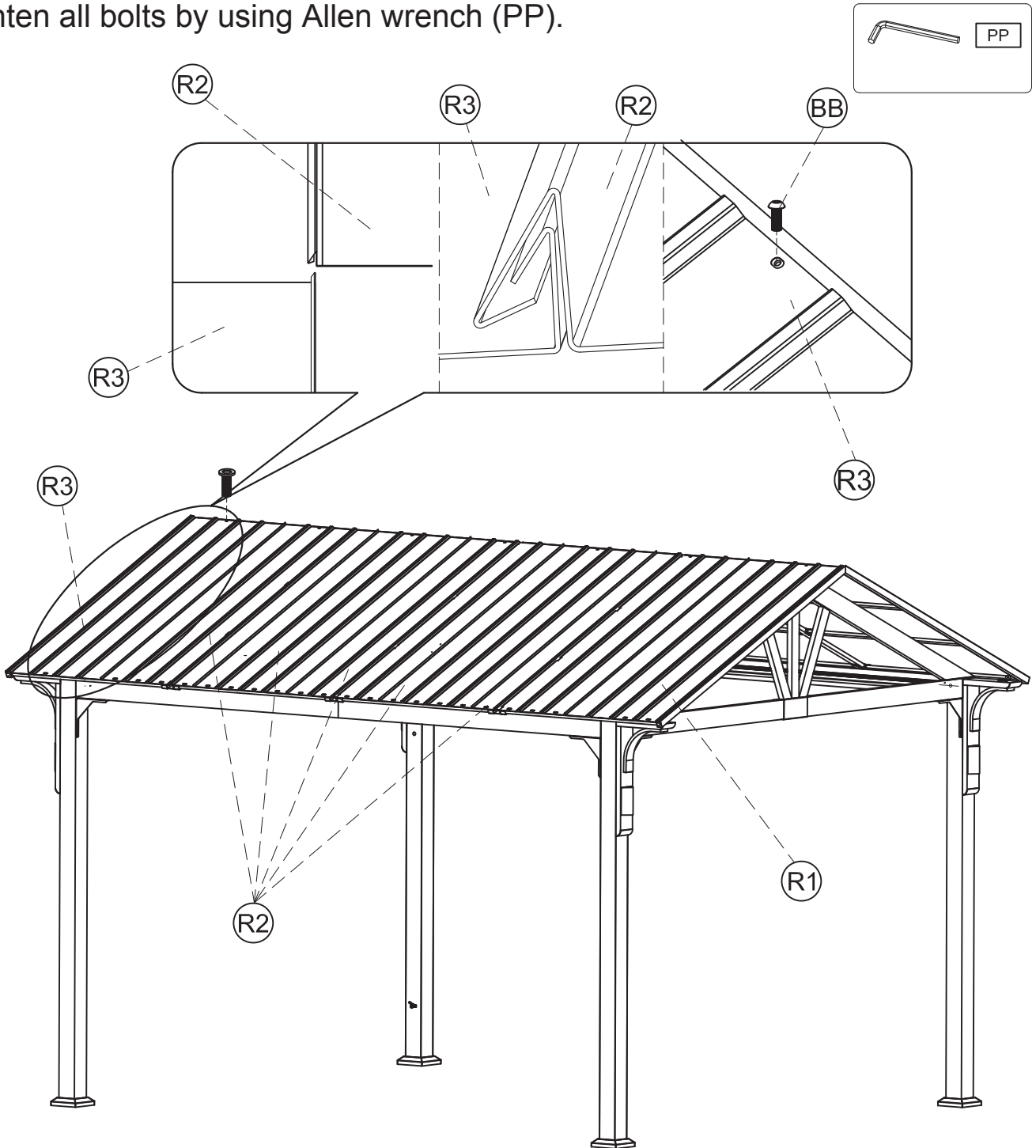
Step 32

1. Insert the Roof panel (R2) into the Roof panel (R1) & (R2) , use the M6*8 bolt (BB) to connect the Roof panel (R2) & Roof connector (O) .
2. Tighten all bolts by using Allen wrench (PP).



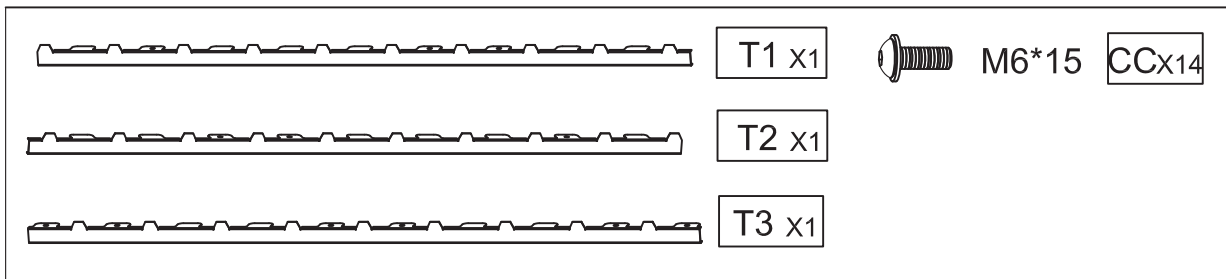
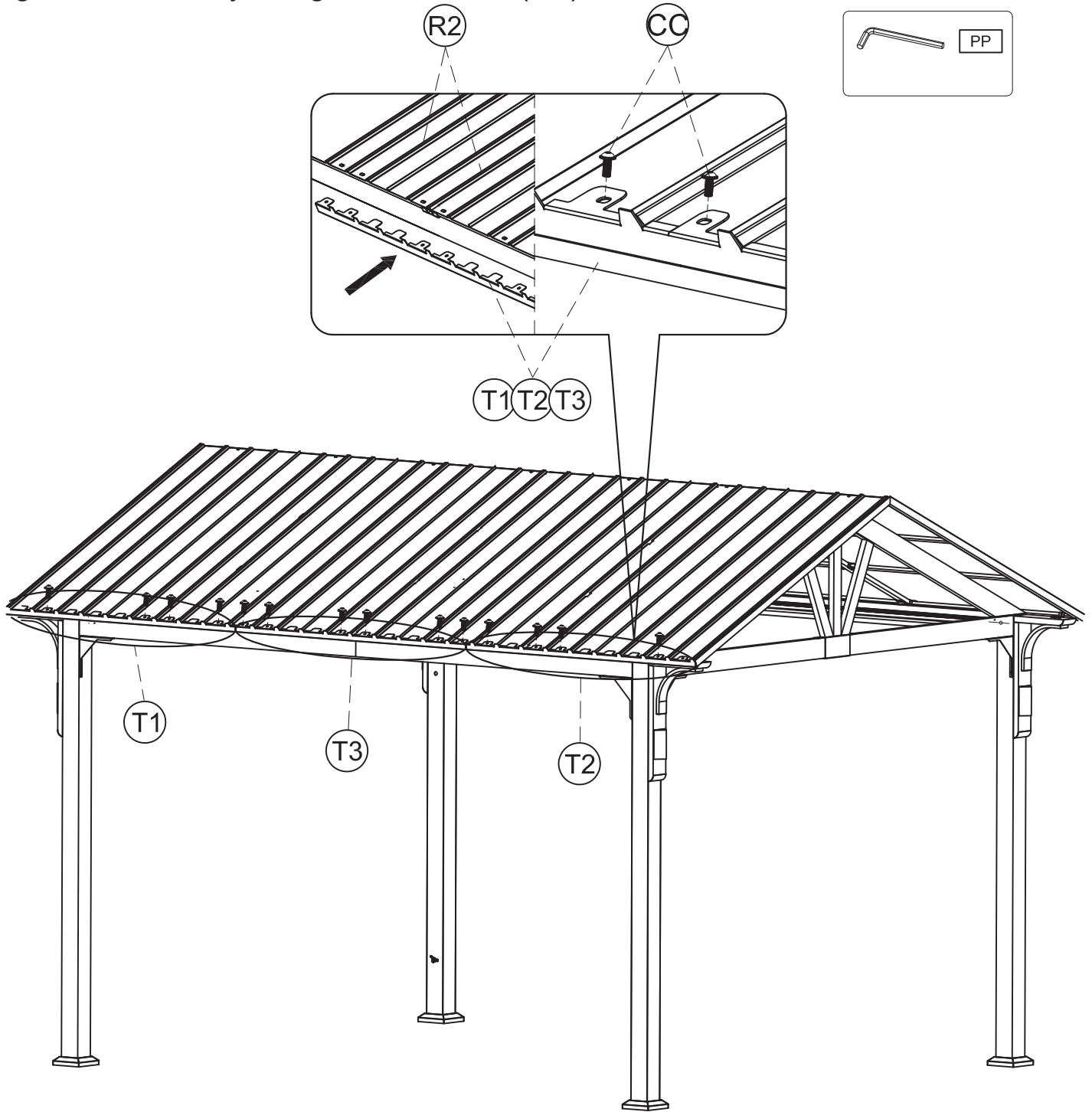
Step 33

1. Insert the Roof panel (R3) into the Roof panel (R2), use M6*8 bolt (BB) to connect the Roof panel (R3) & Roof connector (O) .
2. Tighten all bolts by using Allen wrench (PP).



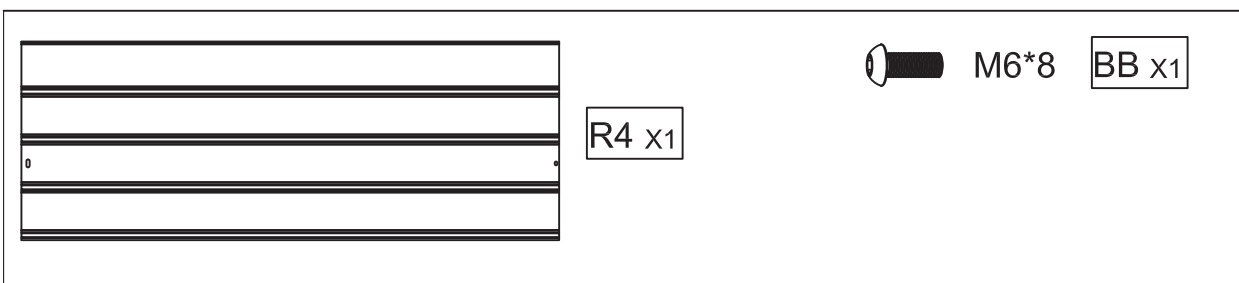
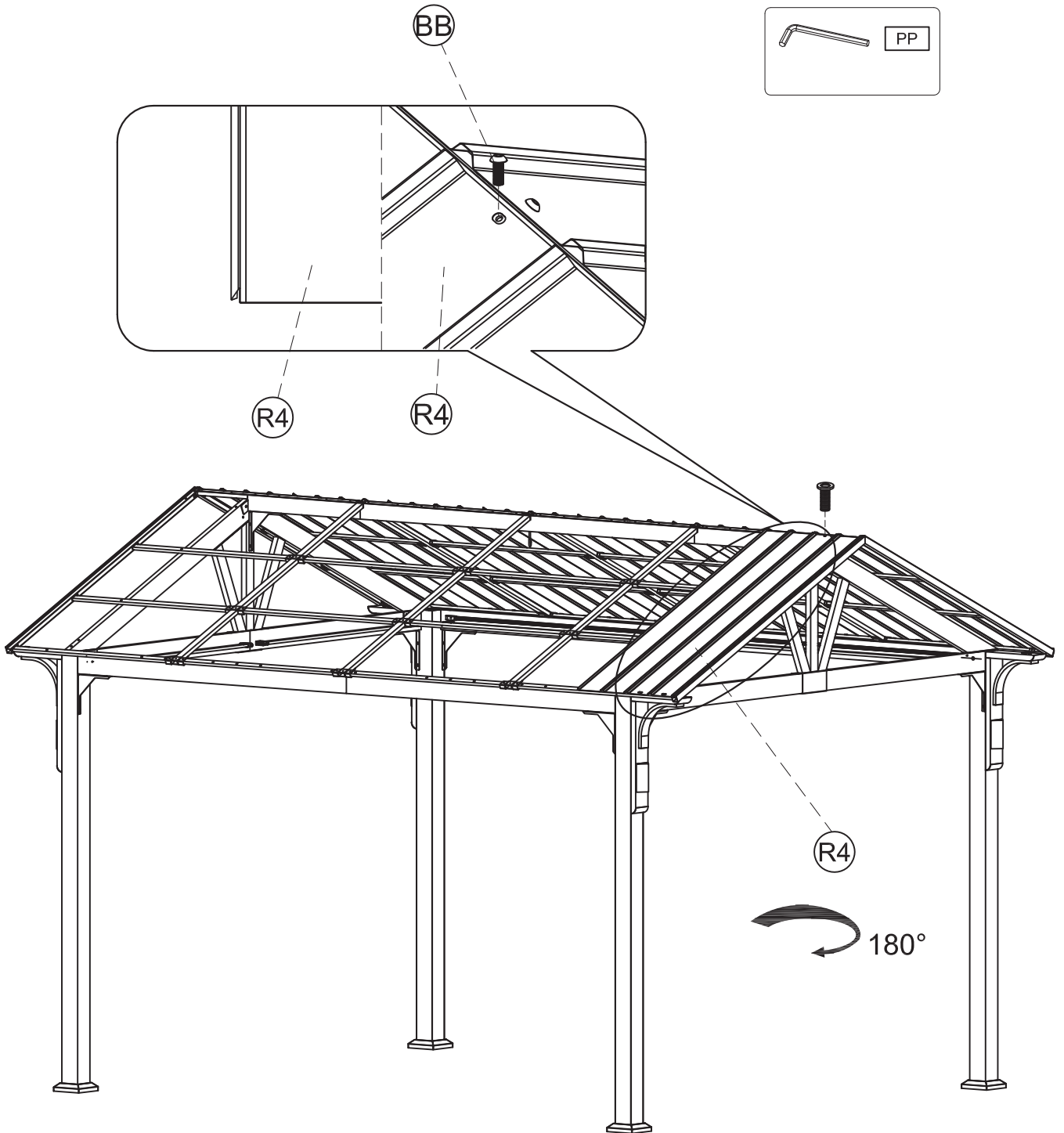
Step 34

1. Attach the Roof edge cap (T1) & (T2) & (T3) through the Roof panel (R1) & (R2) & (R3) to the Rafter branch unit (P1) & (P2) with M6*15 bolt with washer (CC).
2. Tighten all bolts by using Allen wrench (PP).



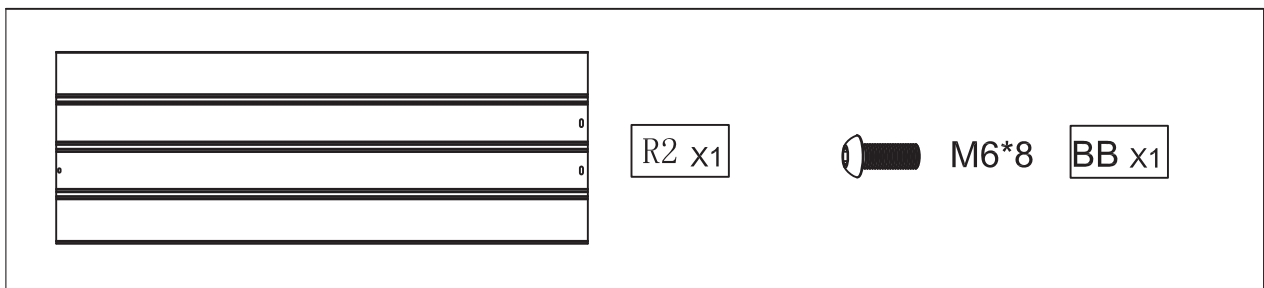
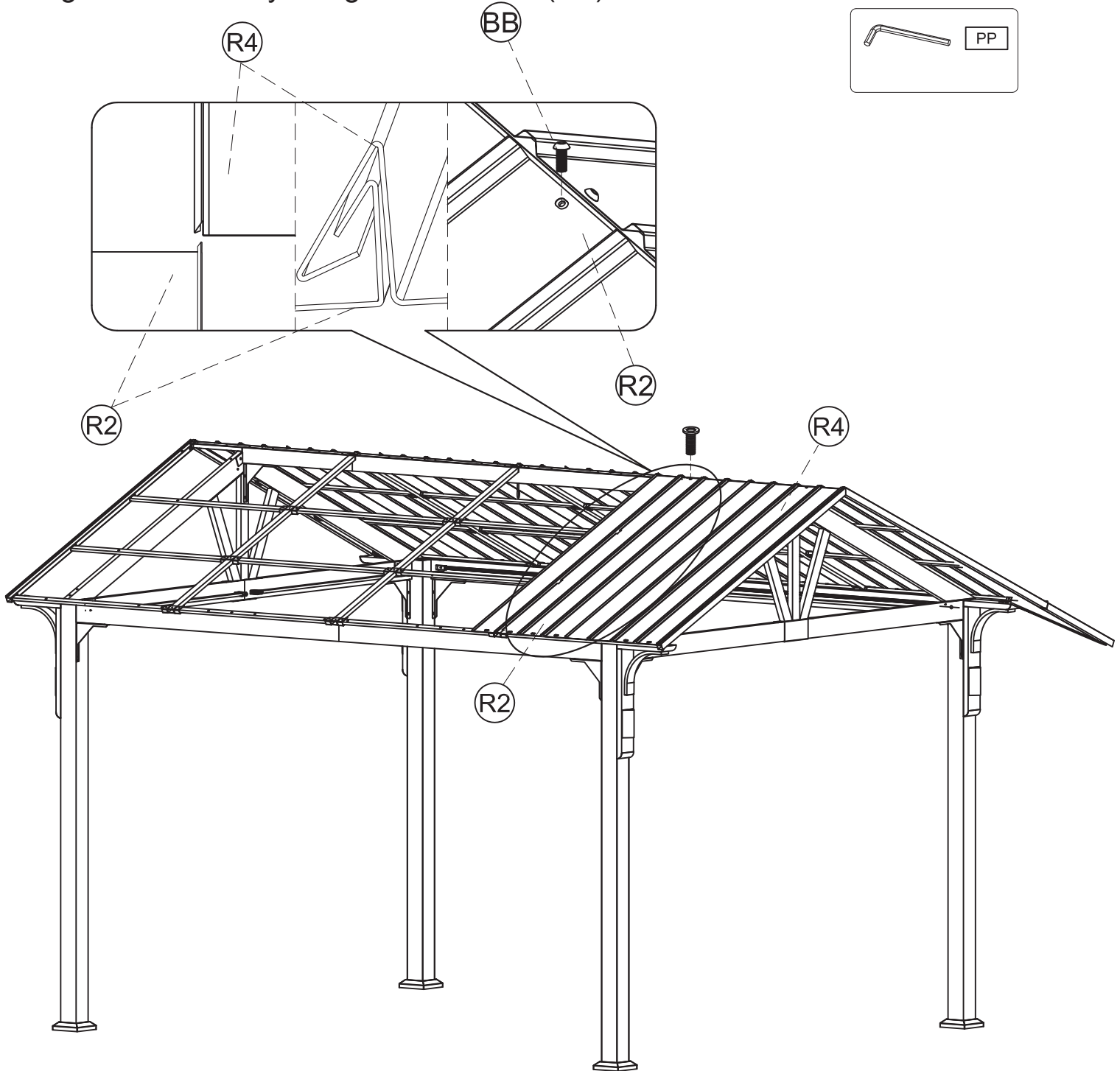
Step 35

1. Attach the Roof panel (R4) to the Roof connector (O) With M6*8 bolt (BB).
2. Tighten all bolts by using Allen wrench (PP).



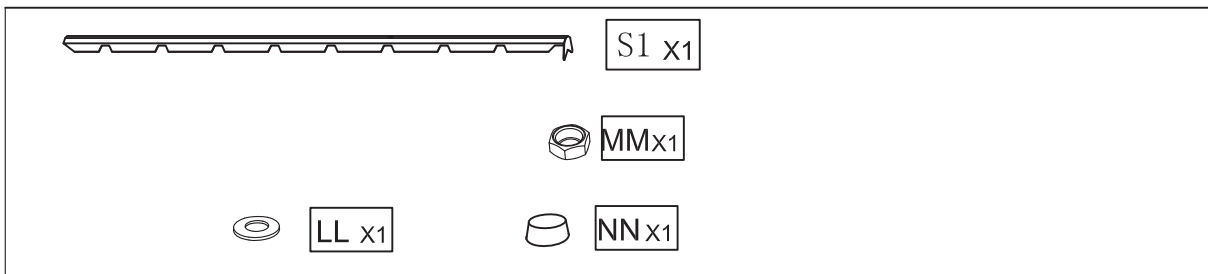
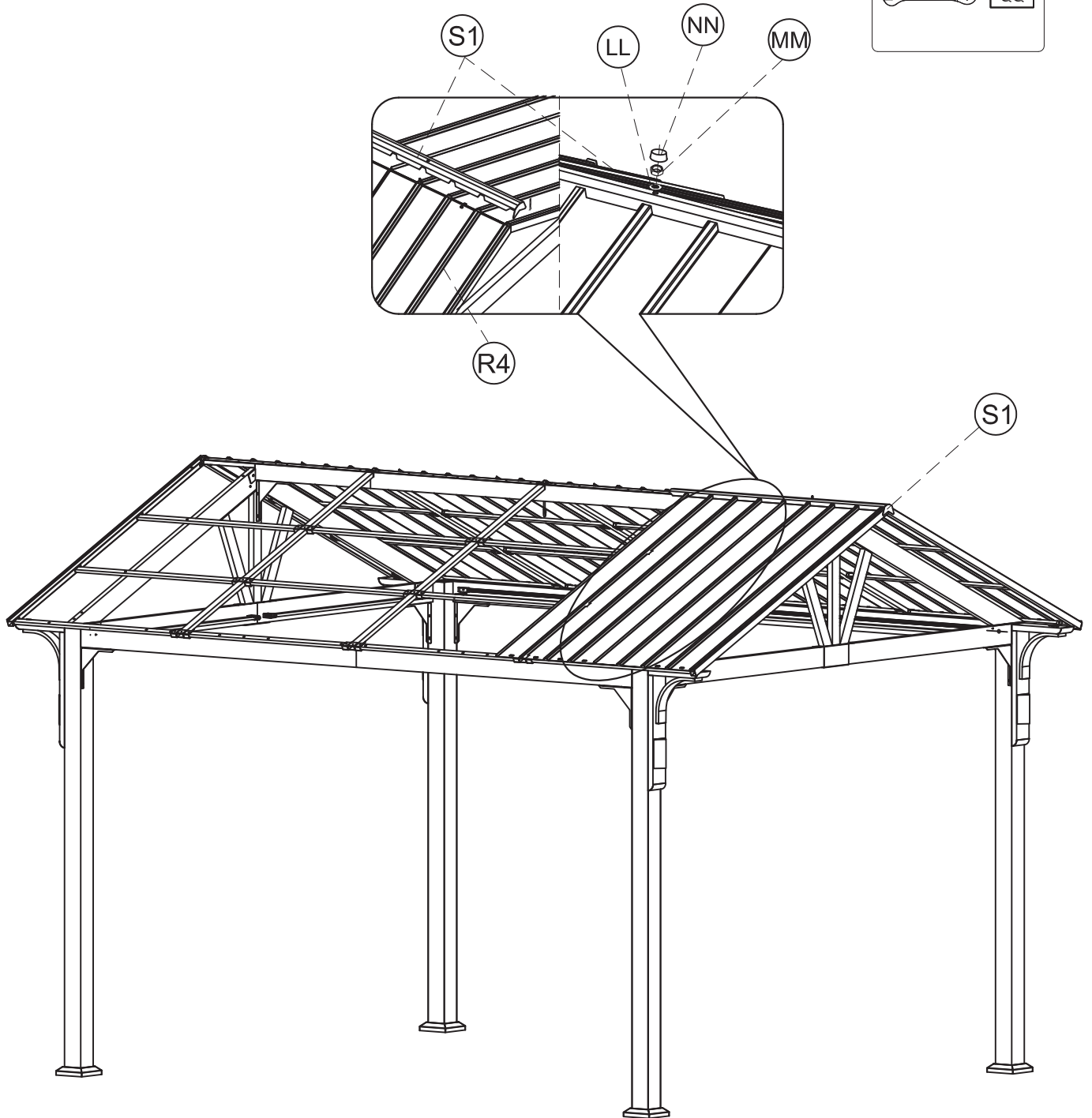
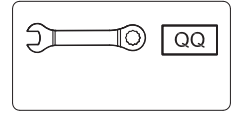
Step 36

1. Insert the Roof panel (R2) into the Roof panel (R4) , use M6*8 bolt (BB) to connect the Roof panel (R2) & Roof connector (O) .
2. Tighten all bolts by using Allen wrench (PP).



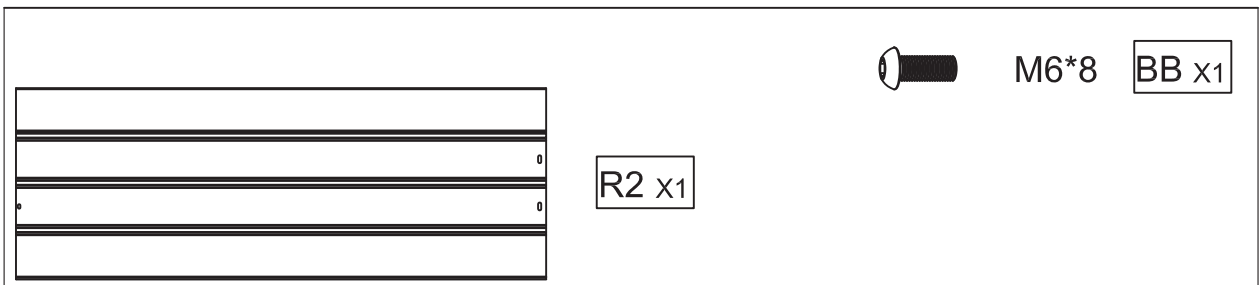
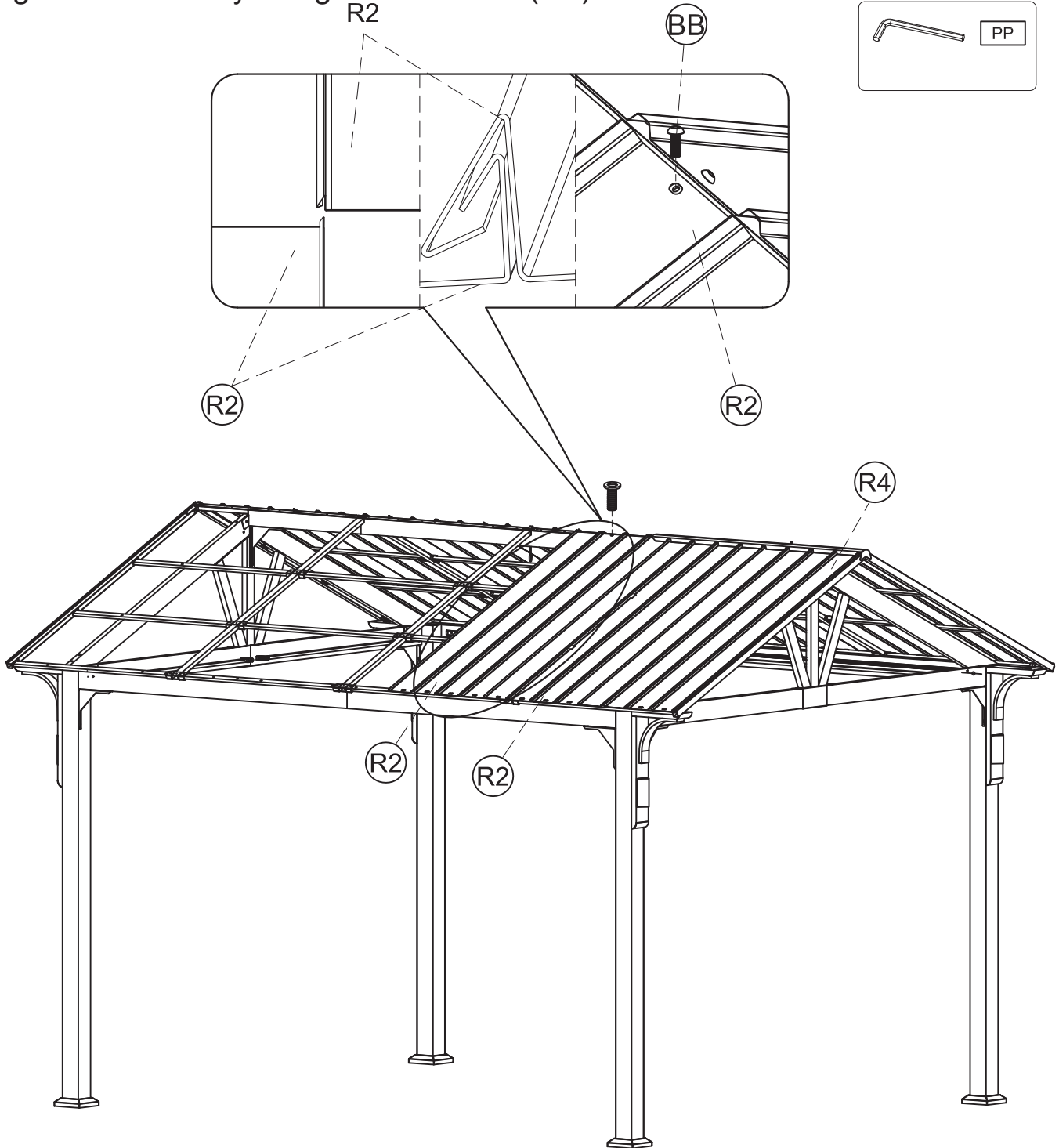
Step 37

1. Use the washer (LL) & Nut (MM) to fix the Roof top cover (S1).
2. Tighten all bolts by using Hex wrench (QQ).
3. Attach the Nut cap (NN) to the Washer (LL) & Nut (MM).



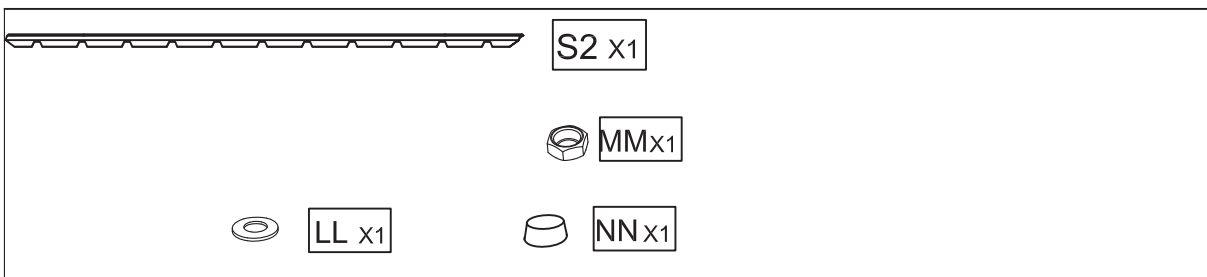
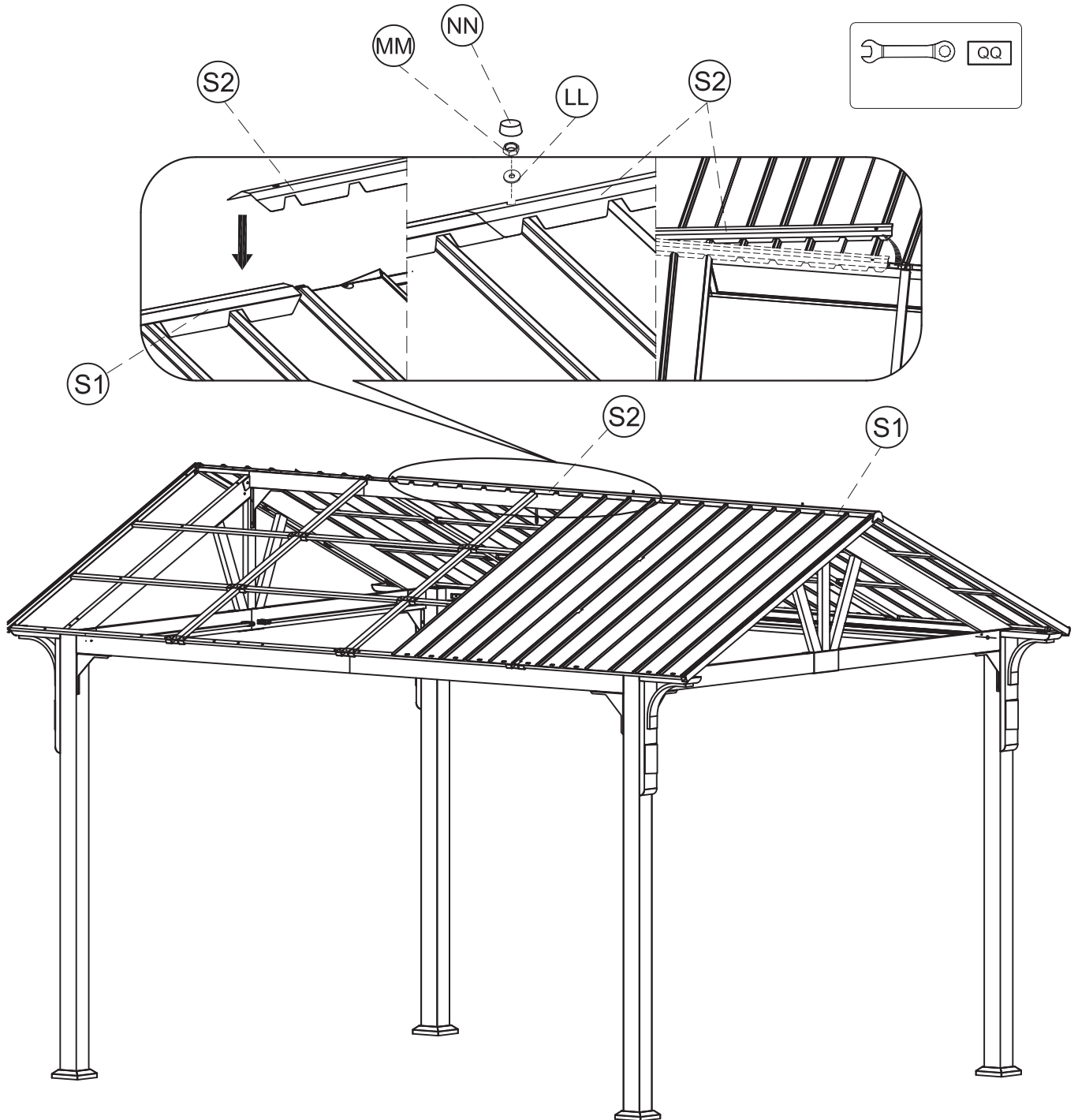
Step 38

1. Insert the Roof panel (R2) into the Roof panel (R2), use the M6*8 bolt (BB) to connect the Roof panel (R2) to the Roof connector (O).
2. Tighten all bolts by using Allen wrench (PP).



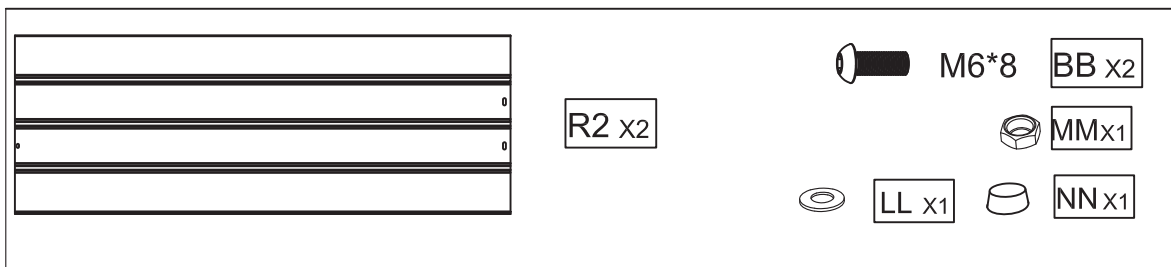
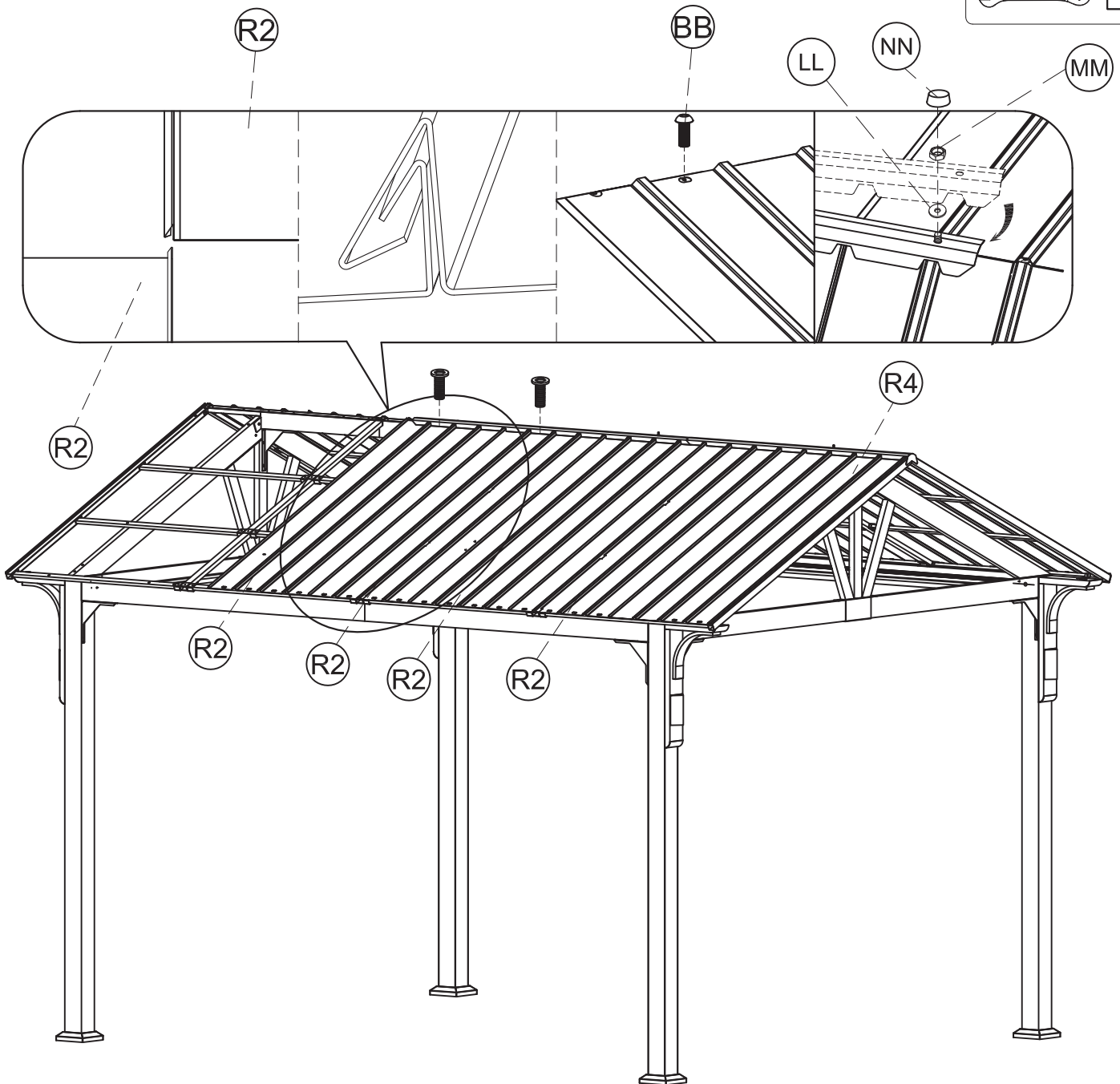
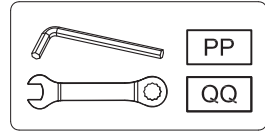
Step 39

1. Use the washer (LL) & Nut (MM) to fix the Roof top cover (S2).
2. Tighten all bolts by using Hex wrench (QQ).
3. Attach the Nut cap (NN) to the Washer (LL) & Nut (MM).



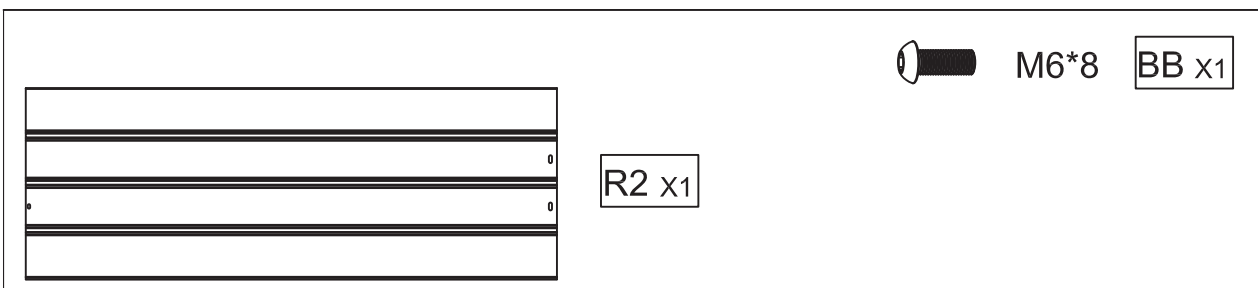
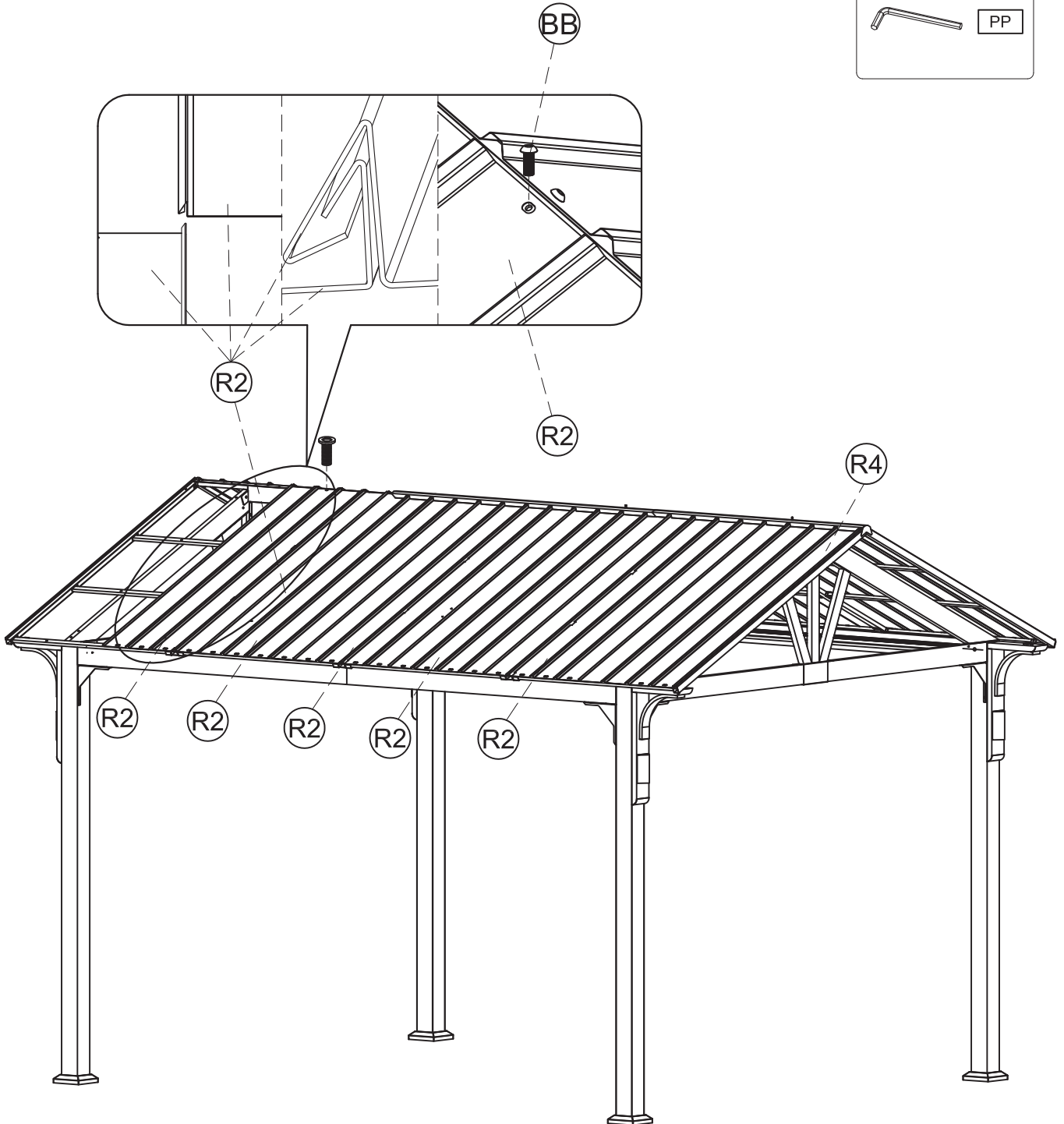
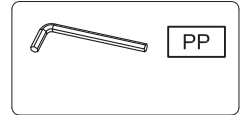
Step 40

1. Insert the Roof panel (R2) into the Roof panel (R2) , use the M6*8 bolt (BB) to connect the Roof panel (R2) & Roof connector (O) .
2. Tighten bolt by using Allen wrench (PP).
3. Use the washer (LL), Nut (MM) & Nut to fix the Roof top cover.
4. Tighten bolts by using Hex wrench (QQ), then attach the Nut cap (NN) to the Nut (MM).



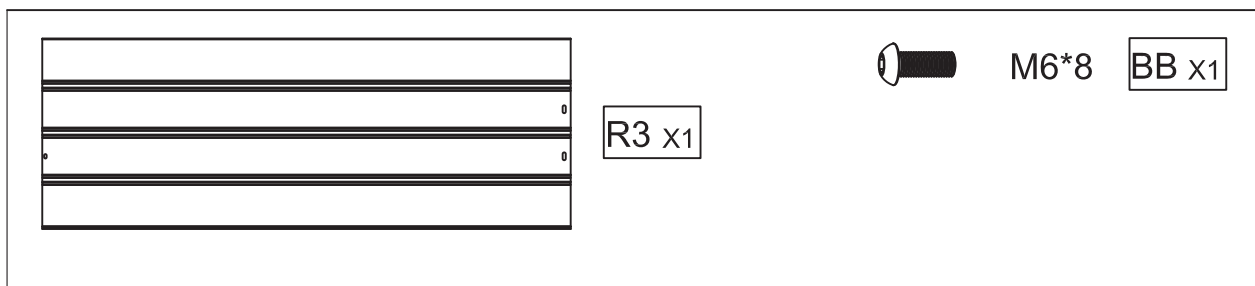
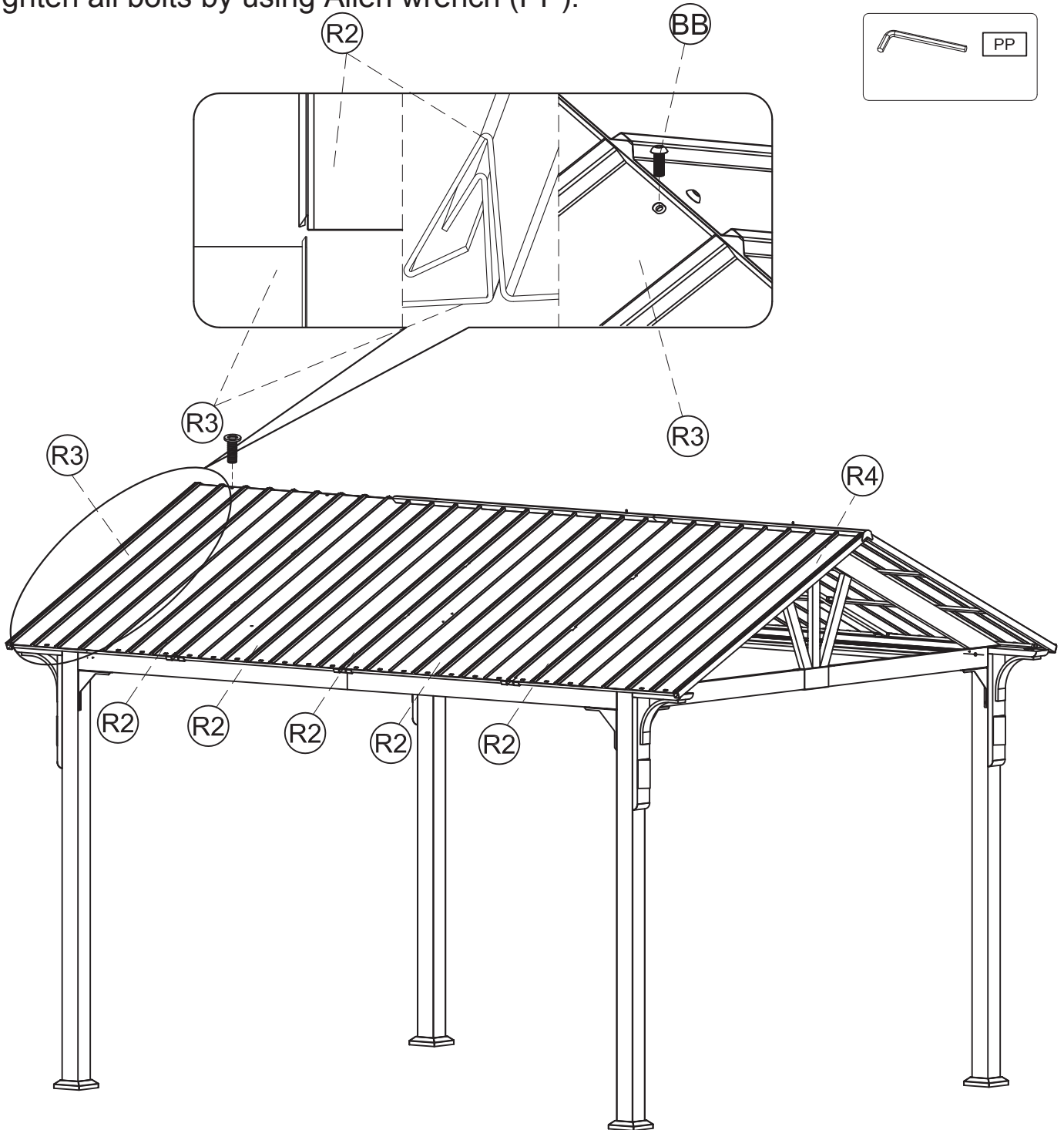
Step 41

1. Insert the Roof panel (R2) into the Roof panel (R2), use the M6*8 bolt (BB) to connect the Roof panel (R2) & Roof connector (O).
2. Tighten all bolts by using Allen wrench (PP).



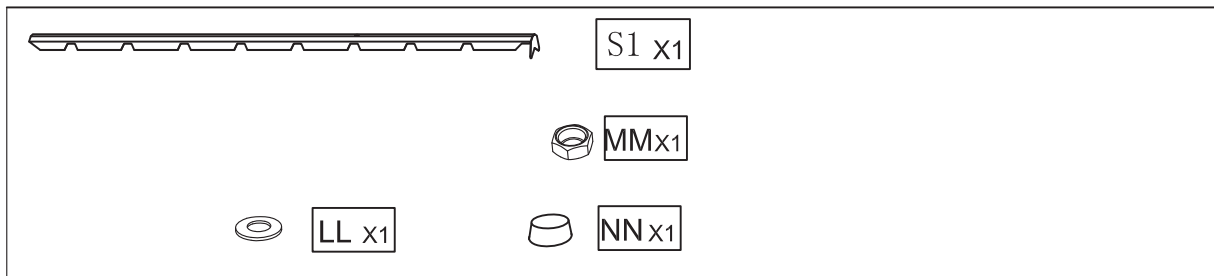
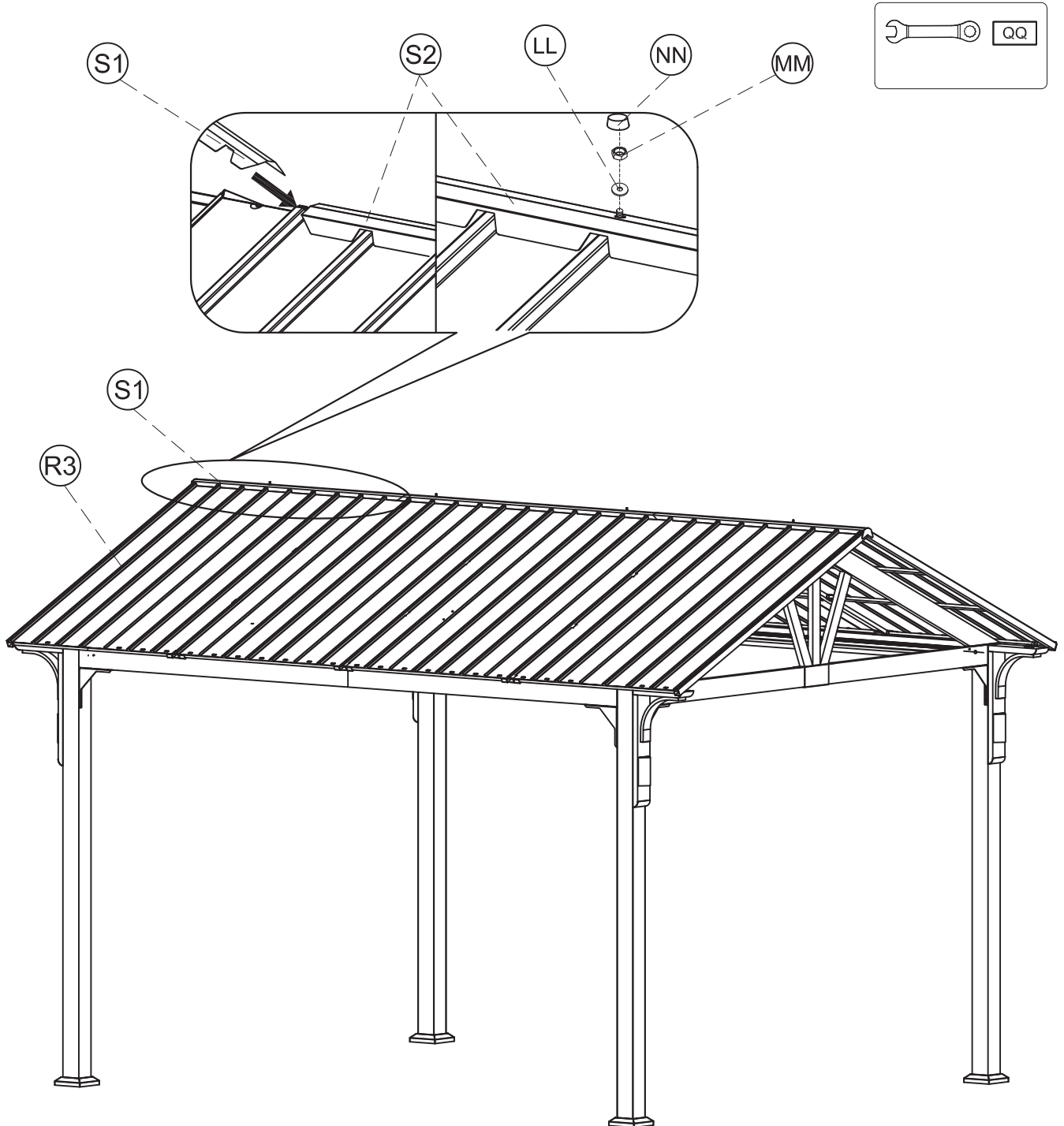
Step 42

1. Insert the Roof panel (R3) into the Roof panel (R2), use the M6*8 bolt (BB) to connect the Roof panel (R3) & Roof connector (O).
2. Tighten all bolts by using Allen wrench (PP).



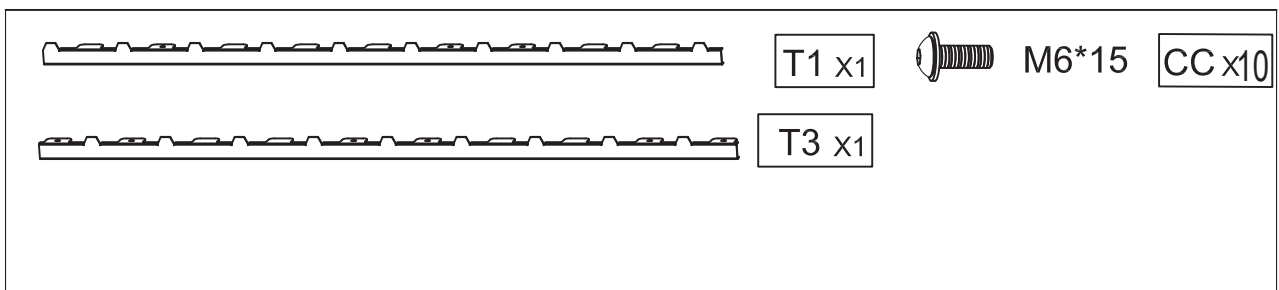
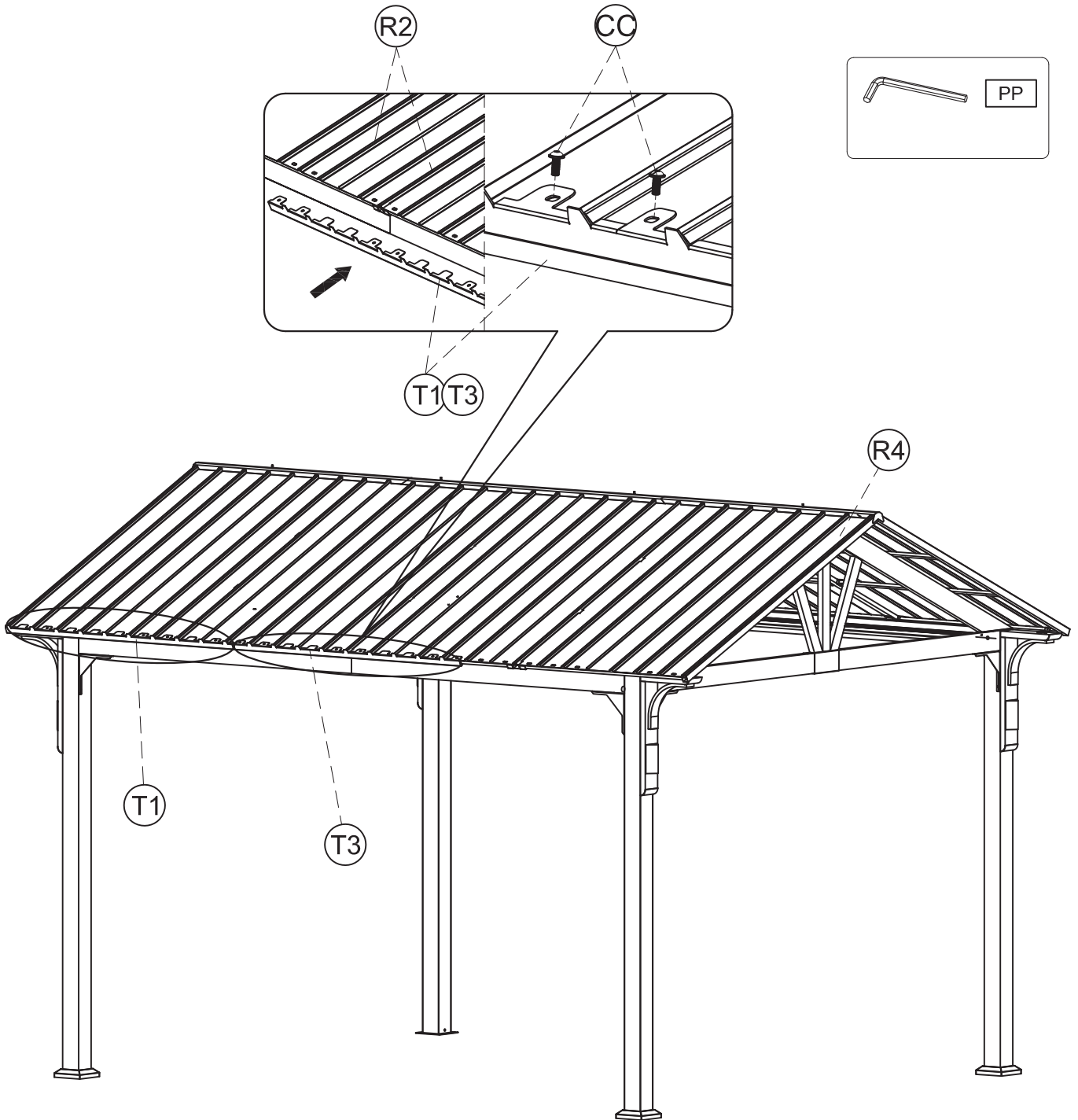
Step 43

1. Use the washer (LL) & Nut (MM) to fix the Roof top cover (S1).
2. Tighten bolts by using Hex wrench (QQ).
3. Attach the Nut cap (NN) to the Washer (LL) & Nut (MM).



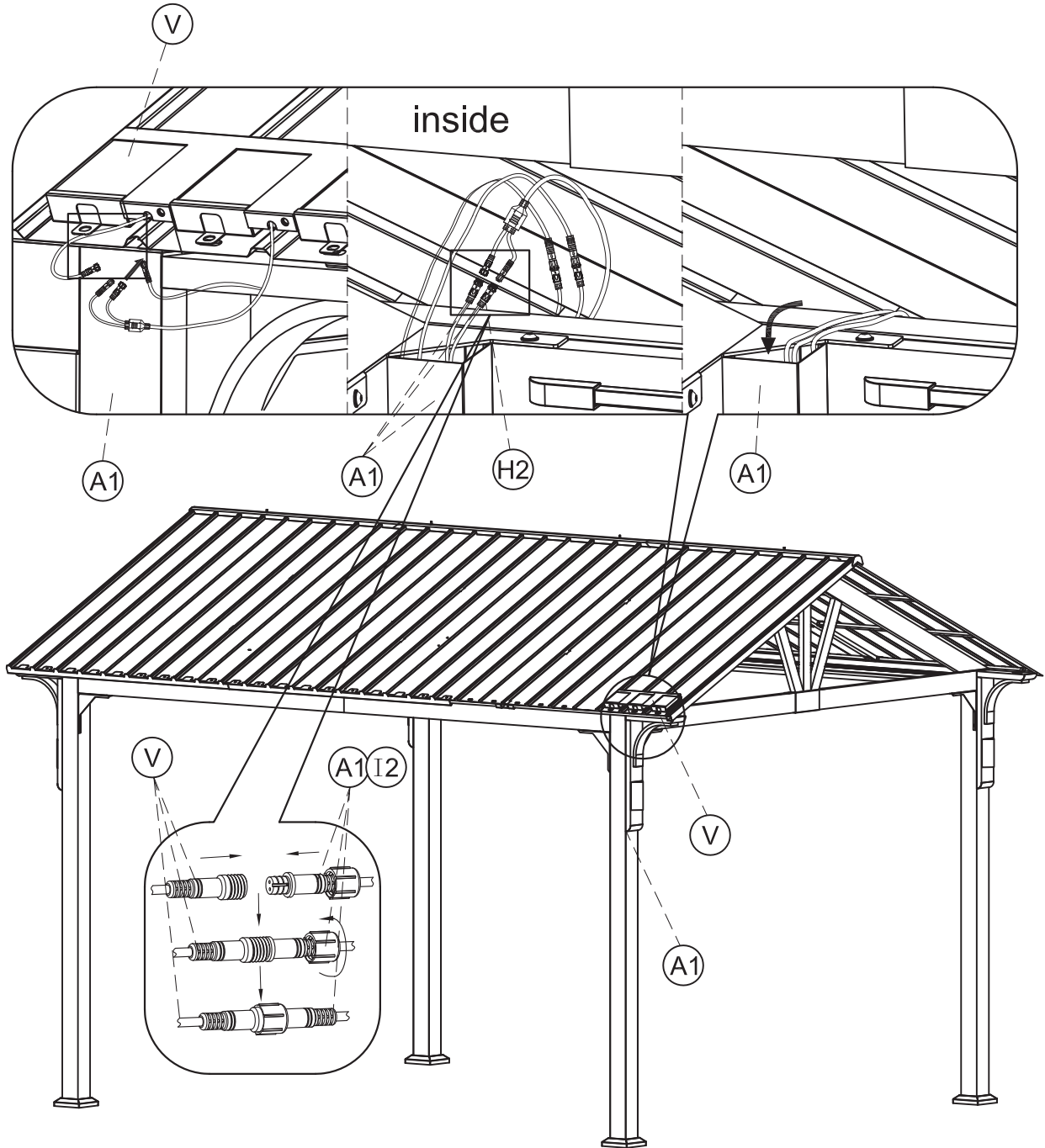
Step 44

1. Attach the Roof edge cap (T1) & (T3) through the Roof panel (R2) & (R3) to the Rafter branch unit (P1) & (P2) with M6*15 bolt with washer (CC).
2. Tighten all bolts by using Allen wrench (PP).



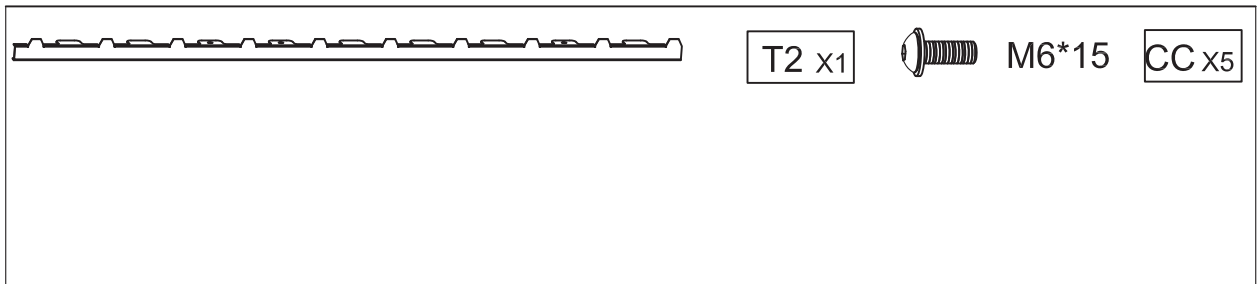
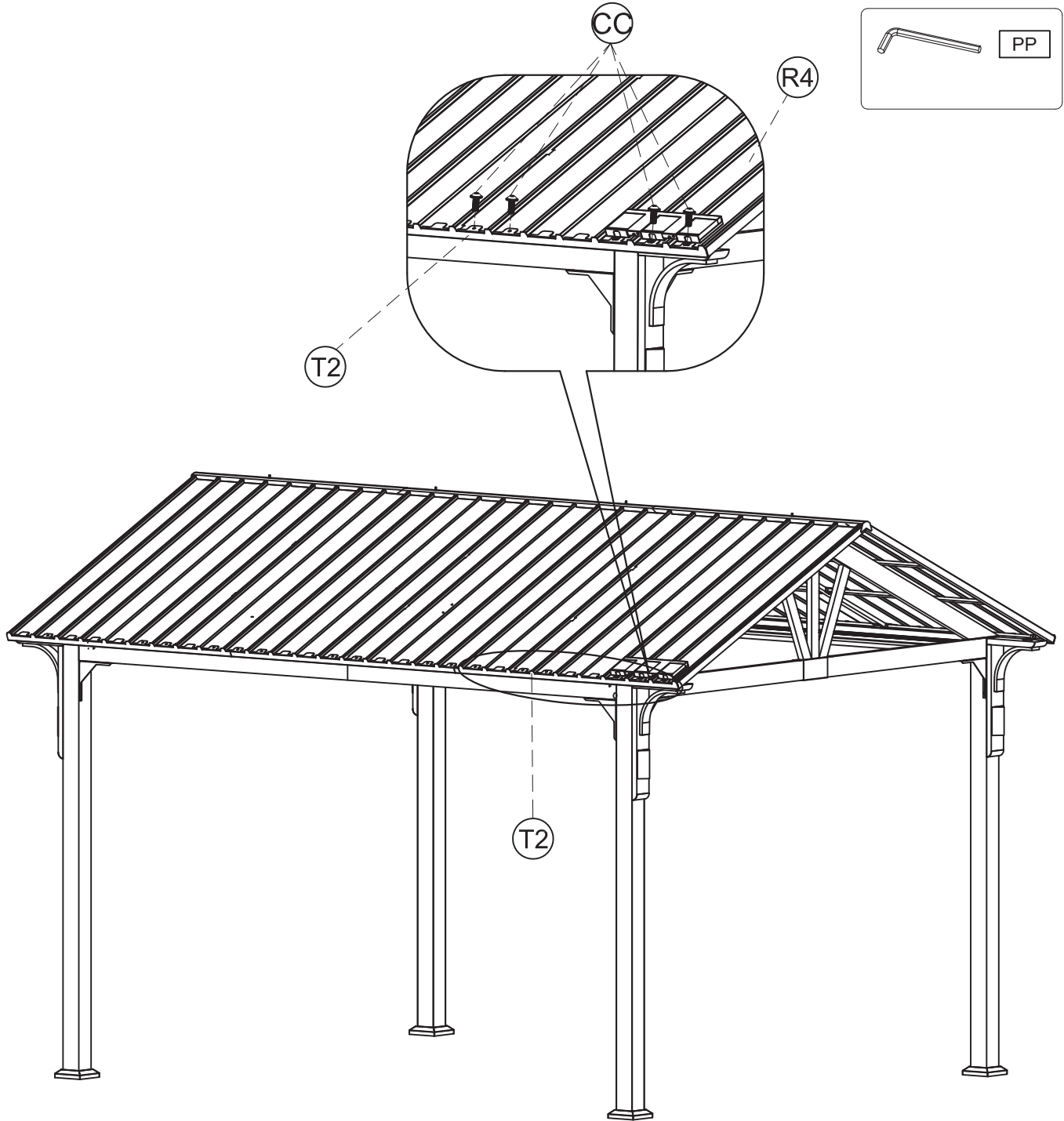
Step 45

1. Attach the Solar panel (V) to the Roof panel.
2. The wires of the switch and the plug are connected to the corresponding wires .
3. Put the wire into Post leg (A1) to hide it.



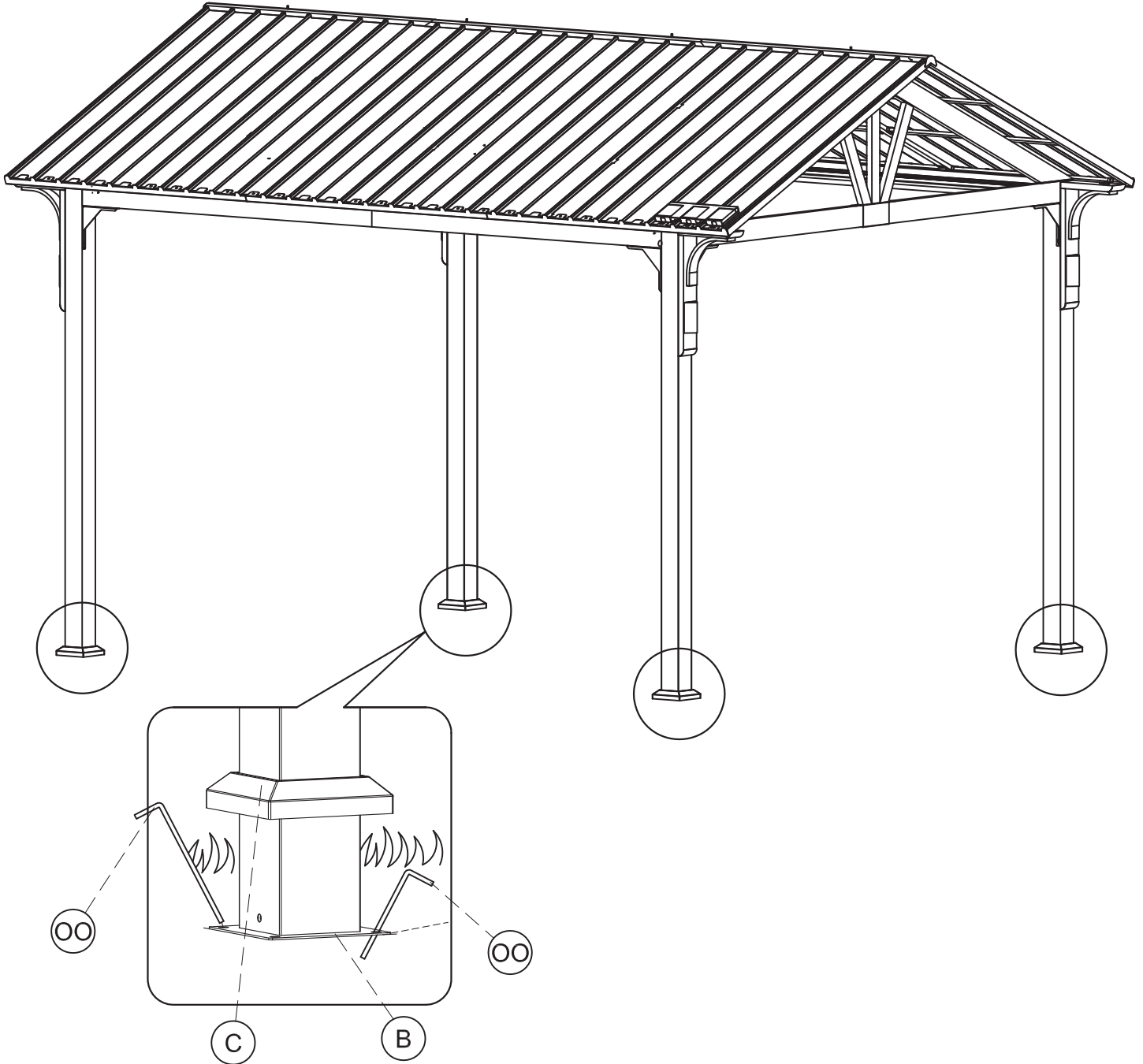
Step 46

1. Attach the Roof edge cap (T2) to the Roof panel (R2) & Roof panel (R4) with M6*15mm bolt with washer (CC).
2. Tighten all bolts by using Allen wrench (PP).



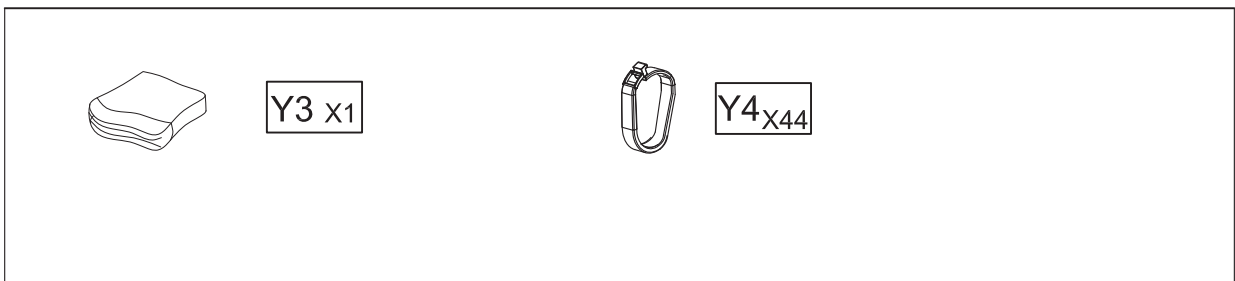
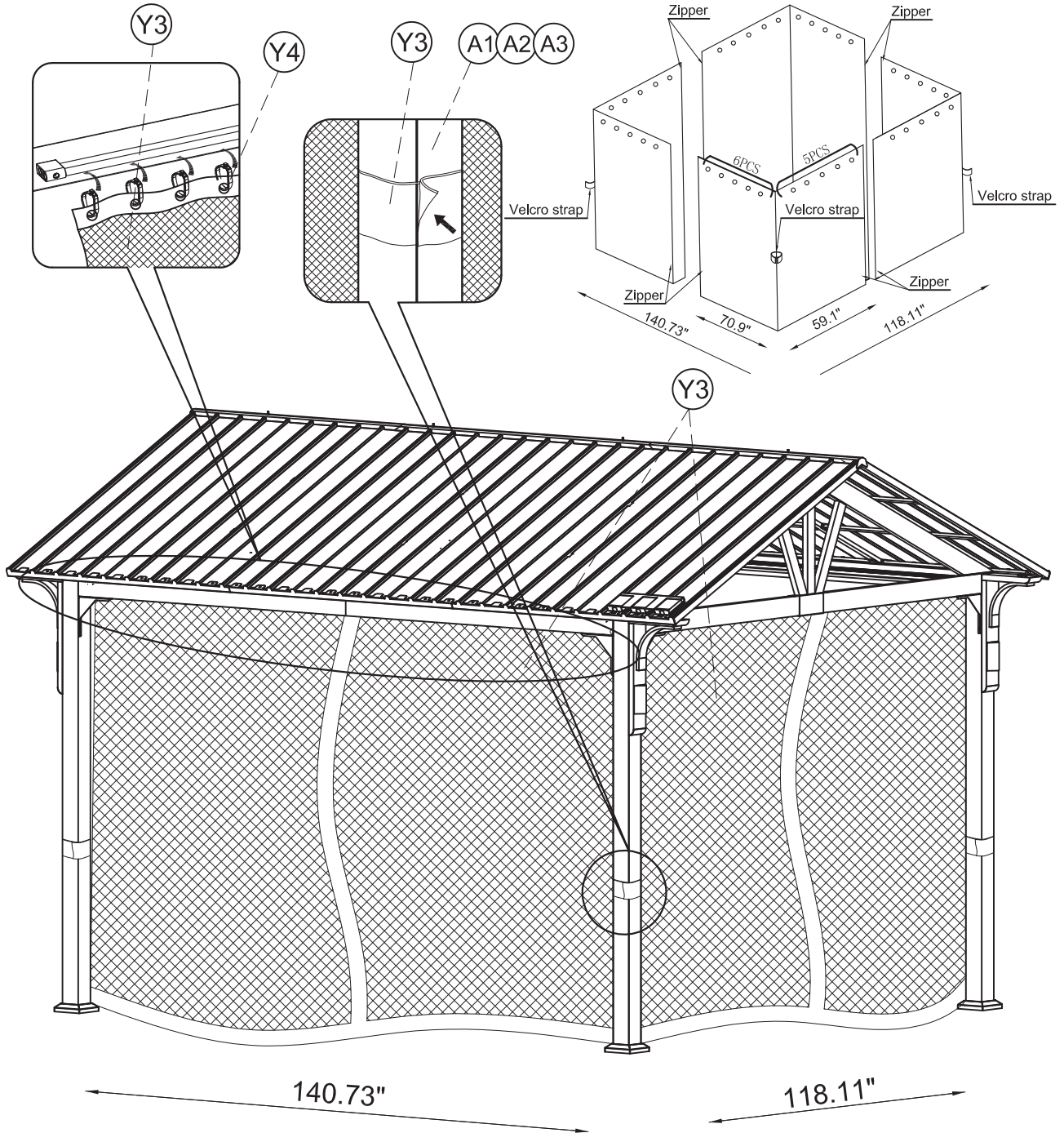
Step 47

1. Insert the Ground stakes (OO) into the holes on the Foot plate (B) and into the ground.
2. Repeat for all corners.



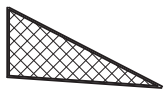
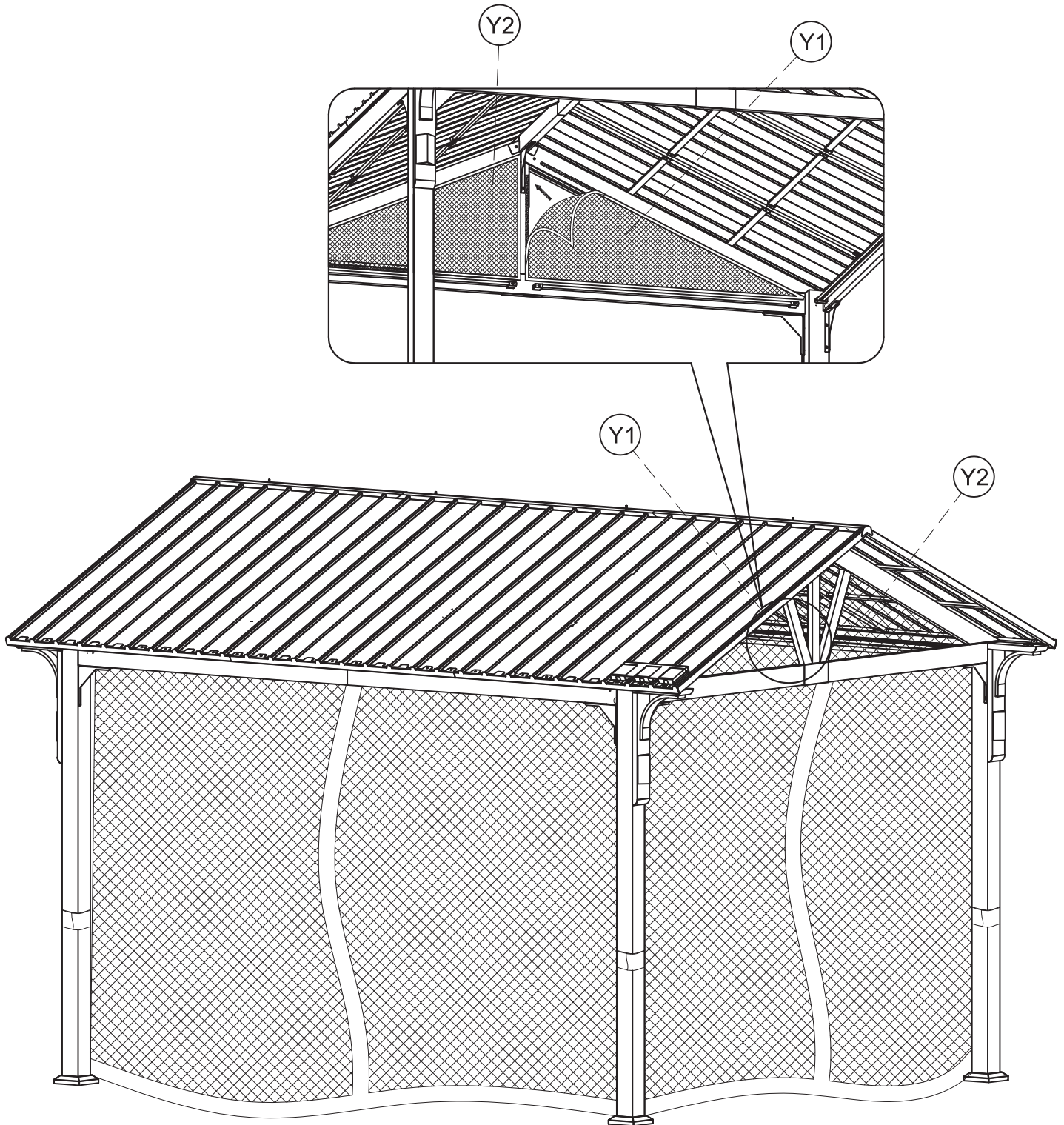
Step 48

1. Hang the Plastic hook (Y4) on the Netting (Y3).
2. Attach the Netting (Y3) to the Long beam & short beam.
3. Velcro strap to the Post leg (A1) & (A2) & (A3).

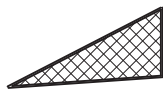


Step 49

1. Attach the Triangular netting (Y1) & (Y2) to the Inclined beam.



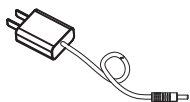
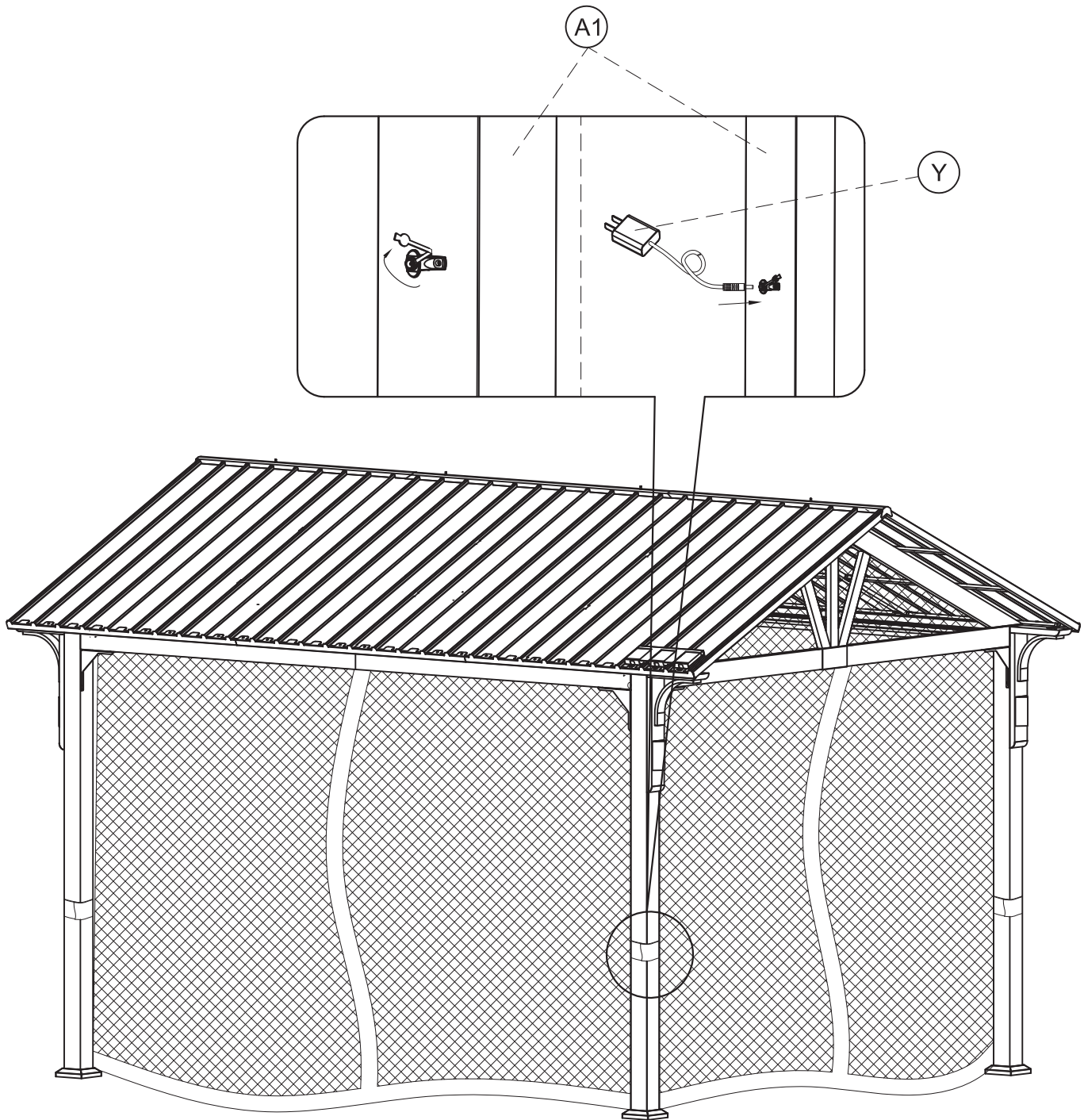
Y1 x2



Y2 x2

Step 50

1. Insert the Plug (Z) into the Post leg (A1).
2. Ensure that all connections are secure before use.
3. Gazebo assembly is completed.



Z x1