

# Body-Solid

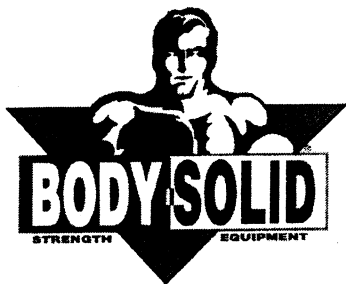
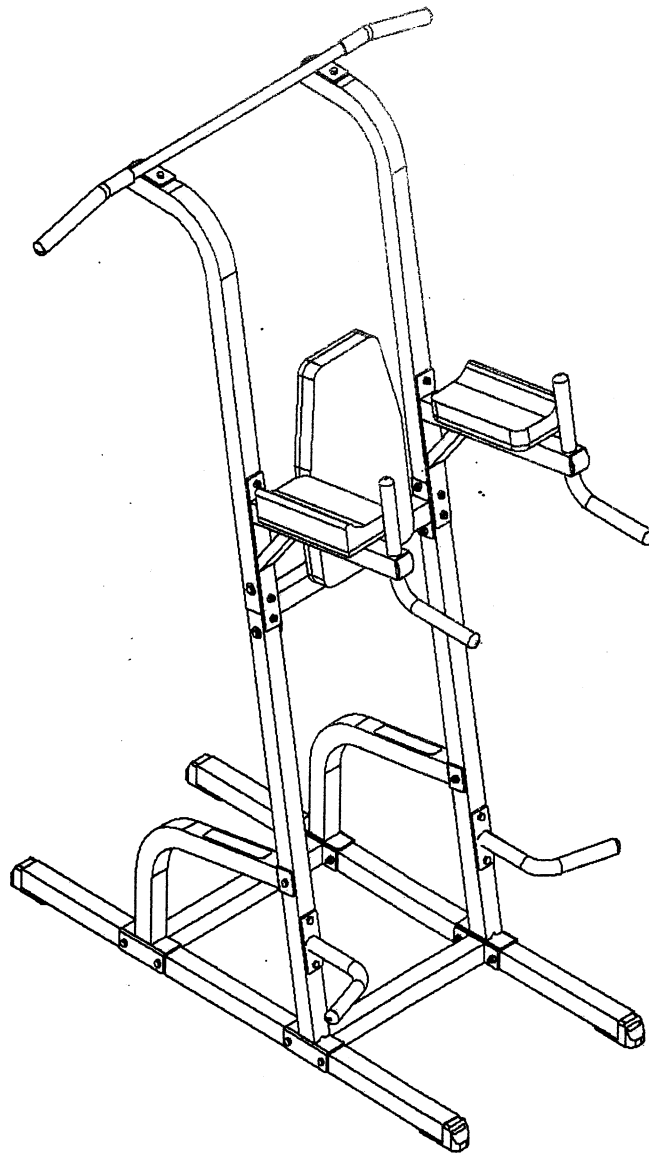

BODY-SOLID, Inc.  
1900 S. Des Plaines Ave.  
Forest Park, IL 60130 USA  
Phone: (708) 427-3555  
Fax: (708) 427-3556  
[www.bodysolid.com](http://www.bodysolid.com)

## GVKR82 OWNER'S MANUAL

# GVKR82 ASSEMBLY INSTRUCTIONS

## TABLE OF CONTENTS

|  |       |
|--|-------|
| General Instructions .....                 | 2     |
| Training Tips and Safety Information ..... | 3     |
| Inspection and Maintenance Schedule .....  | 4     |
| Hardware Illustration .....                | 5     |
| Parts Illustration .....                   | 6     |
| Assembly ( Step 1 ) .....                  | 7-8   |
| Assembly ( Step 2 ) .....                  | 9-10  |
| Assembly ( Step 3 ) .....                  | 11-12 |

# **GVKR82 ASSEMBLY INSTRUCTIONS**

## **GENERAL INSTRUCTIONS**

Thank you for purchasing the Body-Solid equipment. At Body-solid, our goal is to ensure customer satisfaction. If you have any questions about these instructions or have any problems with assembly or parts for this machine, please call our Customer Service Department at 1-800-556-3113.

Prior to assembling any Body-Solid machine, please take the time to read the instructions thoroughly. Please use this manual to make sure that all parts have been included with your shipment. When ordering replacement parts, please refer to the part number and description of each part from this manual. Use only Body-Solid replacement parts when servicing any Body-Solid machine. Failure to do so may void your warranty and could result in personal injury.

Body-Solid equipment is designed to provide the safest, smoothest and most effective workouts possible. After you have finished assembling this product, check all stations to ensure correct operation. If for some reason you experience problems with any functions of this machine, do not continue operation. First, re-check all of the assembly instructions to locate any possible errors made during assembly. If you are not able to correct the problem, contact our Customer Service Department immediately at 1-800-556-3113.

## **TOOLS REQUIRED**

- Socket Wrench
- 5/16", 3/8" and 1/2" Sockets
- Crescent Wrench
- Rubber Mallet

# **GVKR82 ASSEMBLY INSTRUCTIONS**

## **TRAINING TIPS AND SAFETY INFORMATION**

**Before starting any exercise program, it is recommended that you consult your physician and get a complete physical examination. There is a risk assumed by individuals who use this type of equipment. To minimize risk, follow the rules below.**

- Always consult your physician before starting any exercise program.
- Do not allow children or minors to play on or around the equipment.
- Warm up properly before engaging in any weight training regimen.
- Before using, read all the warning labels and instructions on the use of this machine.
- Do not modify the machine in any way.
- Inspect the machine before use for any damaged, worn or missing parts. If there is any doubt about the ability of this equipment to operate safely, do not use the equipment until it is serviced.
- Exercise with care, performing exercises at a smooth, moderate pace. Never perform jerky or uncoordinated movements that may result in injury.
- Never hold your breath while exercising.
- Learn how to perform the exercise correctly before using heavy weight. Correct form is important to avoid injury and to ensure that you work the proper muscle groups.
- It is recommended that you train with a training partner.
- Keep body and clothing clear of cables and moving parts when the machine is in use.
- Know your limitations. If you are new to resistance training or are starting an exercise routine after a prolonged lay-off, start slowly and build up to a more intense routine.

**Failure to follow these rules may result in serious injury. If unsure about the proper use of the machine, consult your local Body-Solid distributor or call the Body-Solid Customer Service department at 1-800-556-3113.**

# **GVKR82 ASSEMBLY INSTRUCTIONS**

## **INSPECTIONS AND MAINTENANCE SCHEDULE**

**There is a risk assumed by individuals who use this type of equipment. To minimize risk, follow the rules below.**

- Inspect equipment daily, ensuring that all nuts, bolts and screws are fully tightened.
- Inspect cables daily ensuring they are routed properly and not worn, frayed or stretched. Check and adjust tension on cables daily.
- When using pop-pin adjustments, always make sure the plunger for the pop-pin is securely inserted into an adjustment hole.
- Before performing any exercise, always make sure all ball-pins, ring-pins, pop-pins and selector pins are inserted properly and all snap-links are properly closed.
- Replace worn parts immediately.
- Human perspiration is corrosive. Clean your machine regularly. Wipe down and dry upholstery and frame pieces on a daily basis.
- Every week clean the chrome guide rods with a dry cloth and apply a coat of dry silicon spray or Teflon based spray lubricant.
- Every week clean and lubricate all non-chrome guide rods and all seat posts and adjustments for starting positions.
- Every week check hand grips, rollers and non-skid surfaces for wear.
- Only use Body-Solid parts. Parts from other manufacturers or any other modifications will void the warranty and may result in serious injury.
- Do not use this machine with damaged, worn or missing parts.
- If there is any doubt about the ability of this equipment to operate safely, do not use the equipment until it is serviced.
- Please ensure that all warning stickers are visible and acknowledged by users of the equipment.

**Failure to follow these rules may result in serious injury. If unsure about the proper use of the machine, consult your local Body-Solid distributor or call the Body-Solid Customer Service department at 1-800-556-3113.**

# GVKR82 ASSEMBLY INSTRUCTIONS

## HARDWARE ILLUSTRATION

|  | Qty.    |
|--|---------|
| A1. M10X70L HEX HEAD BOLT -----              | [18PCS] |
| A2. M10X75L HEX HEAD BOLT -----              | [8PCS]  |
| A3. M8X70L HEX HEAD BOLT -----               | [6PCS]  |
| B1. M10 NYLON LOCK NUT -----                 | [26PCS] |
| C1. M10 (I.D)WASHER -----                    | [16PCS] |
| C2. M8 (I.D)WASHER -----                     | [6PCS]  |
| C3. M8 SPRING WASHER -----                   | [6PCS]  |
| D1. 2"X2" FOOT CAP (9211-024) -----          | [4PCS]  |
| D2. 2"X2"X1.8t END CAP (9211-087) -----      | [5PCS]  |
| D6. 38X195 RUBBER PAD (9310-030) -----       | [2PCS]  |
| D7. $\phi$ 1" ROUND END CAP (9260-021) ----- | [8PCS]  |

A1



A2



A3



B1



C1



C2



C3



D1

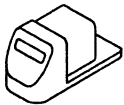

D2



D6

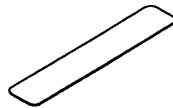

D7

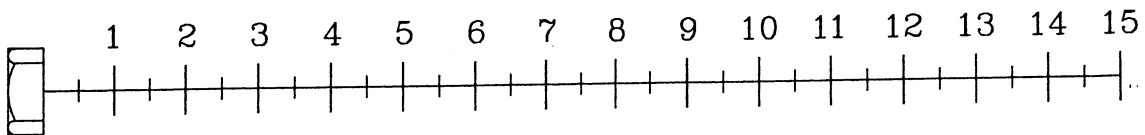

# GVKR82 ASSEMBLY INSTRUCTIONS

## PARTS ILLUSTRATION

A [2PCS]

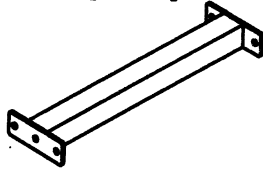

B [1PCS]

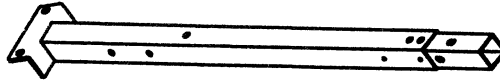

C [1PCS]

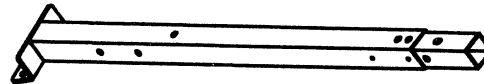

D [1PCS]

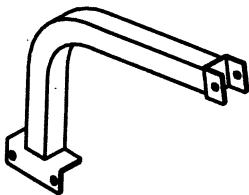

E [1PCS]

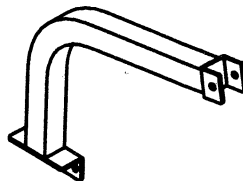

F [1PCS]



M [1PCS]



G [1PCS]

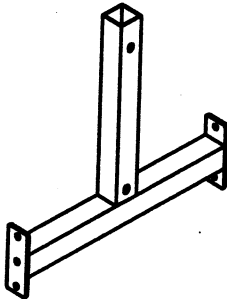

I [1PCS]

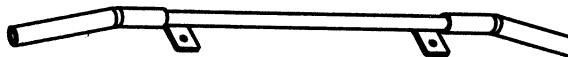

J [2PCS]

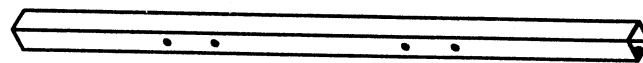

K [1PCS]

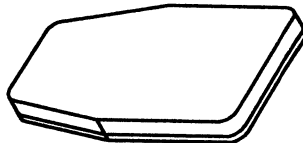

L [2PCS]



H [2PCS]

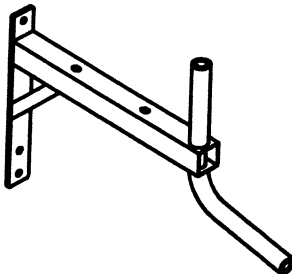

N [2PCS]

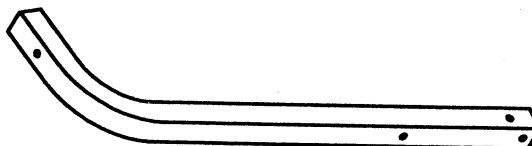

# GVKR82 ASSEMBLY INSTRUCTIONS

## ASSEMBLY- STEP 1

*\*\*Note : Do Not fully tighten frame bolts and nuts until after completing Step 2*

The following Parts and Hardware will be needed to complete Step 1

| Parts Description |             |                         | Hardware Description |             |                         |
|-------------------|-------------|-------------------------|----------------------|-------------|-------------------------|
| <u>Qty</u>        | <u>Part</u> | <u>Part Description</u> | <u>Qty</u>           | <u>Part</u> | <u>Part Description</u> |
| 1                 | A           | Bottom Cross Frame      | 4                    | A2          | M10x75L Hex Head Bolt   |
| 2                 | J           | Bottom Base Frame       | 4                    | B1          | M10 Nylon Lock Nut      |
| 1                 | D           | Right Support Frame     | 4                    | D1          | 2x2 Foot Cap            |
| 1                 | E           | Left Support Frame      | 2                    | D6          | 38x195 Rubber Pad       |

### Step by Step

1. Attach 4 (D1) to 2 (J) - Bottom Base Frames
2. Attach (A) - Bottom Cross Frame, (D) - Right Support Frame, and (E) - Left Support Frame to 2 (J) - Bottom Base Frames (note:2 (J) - Bottom Base Frames must be positioned so that the length between the bolt holes and the end of the tubing is longer in the front as shown in picture)
3. Attach 2 (D6) 38x195 Rubber Pad to (D) Right Support Frame and (E) Left Support Frame

# GVKR82 ASSEMBLY INSTRUCTIONS

## ASSEMBLY- STEP 1

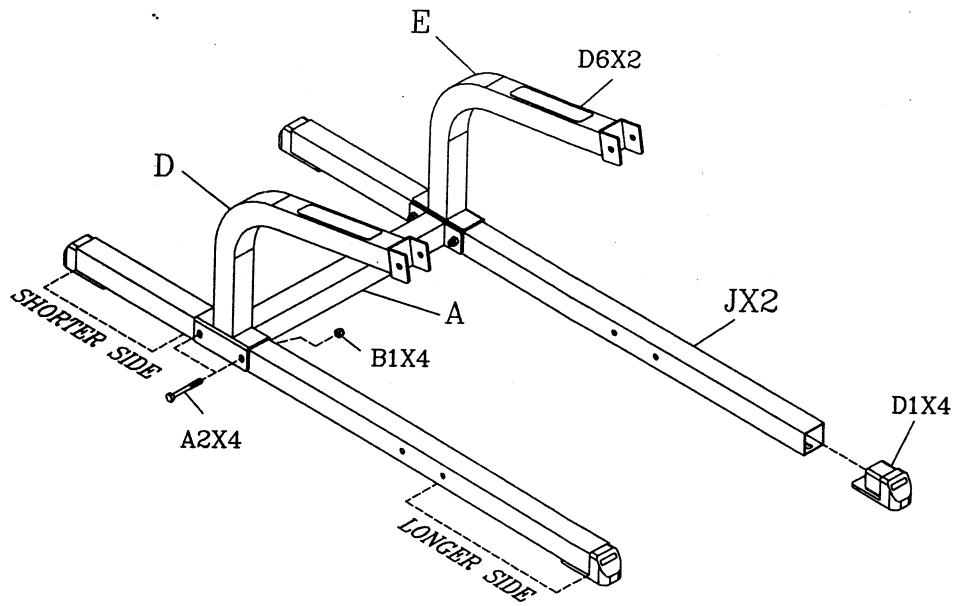

# GVKR82 ASSEMBLY INSTRUCTIONS

## ASSEMBLY- STEP 2

*\*\*Note : Do Not fully tighten frame bolts and nuts until after completing Step 2*

The following Parts and Hardware will be needed to complete Step 2

| Parts Description |      |                     | Hardware Description |      |                       |
|-------------------|------|---------------------|----------------------|------|-----------------------|
| Qty               | Part | Part Description    | Qty                  | Part | Part Description      |
| 1                 | A    | Bottom Cross Frame  | 10                   | A1   | M10×70L hex head bolt |
| 1                 | B-1  | Right Upright Frame | 4                    | A2   | M10×75L hex head bolt |
| 1                 | C-1  | Left Upright Frame  | 14                   | B1   | M10 nylon lock nut    |
| 1                 | F    | Left Push Up Bar    | 8                    | C1   | M10 ID washer         |
| 1                 | G    | Back Pad Frame      | 1                    | D2   | 2×2 end cap           |
| 1                 | M    | Right Push Up Bar   | 2                    | D7   | 1" round end cap      |
| 2                 | N    | Top Frame           |                      |      |                       |

### Step by Step

1. Place (A) - Bottom Cross Frame in between 2 (J) - Bottom Base Frames
2. Attach (B) - Right Upright Frame and (C) - Left Upright Frame to (A) - Bottom Cross Frame and 2 (J) - Bottom Base Frames, next bolt (B) - Right Upright Frame to (D) - Right Support Frame and (C) - Left Upright Frame to (E) - Left Support Frame
3. Attach 2(N) - Top Frame to (B) - Right Upright Frame and (C) Left Upright Frame
4. Attach (G) - Back Pad Frame to (B) - Right Upright Frame and (C) - Left Upright Frame
5. Attach (F) - Left Push Up Bars to (C) - Left Upright Frame and (G) – Back Pad Frame
6. Attach (K) - Right Push Up Bars to (B) - Right Upright Frame and (G) - Back Pad Frame

**\*\*Securely Tighten All Frame Bolts Used in Steps 1 and 2**

# GVKR82 ASSEMBLY INSTRUCTIONS

## ASSEMBLY-STEP 2

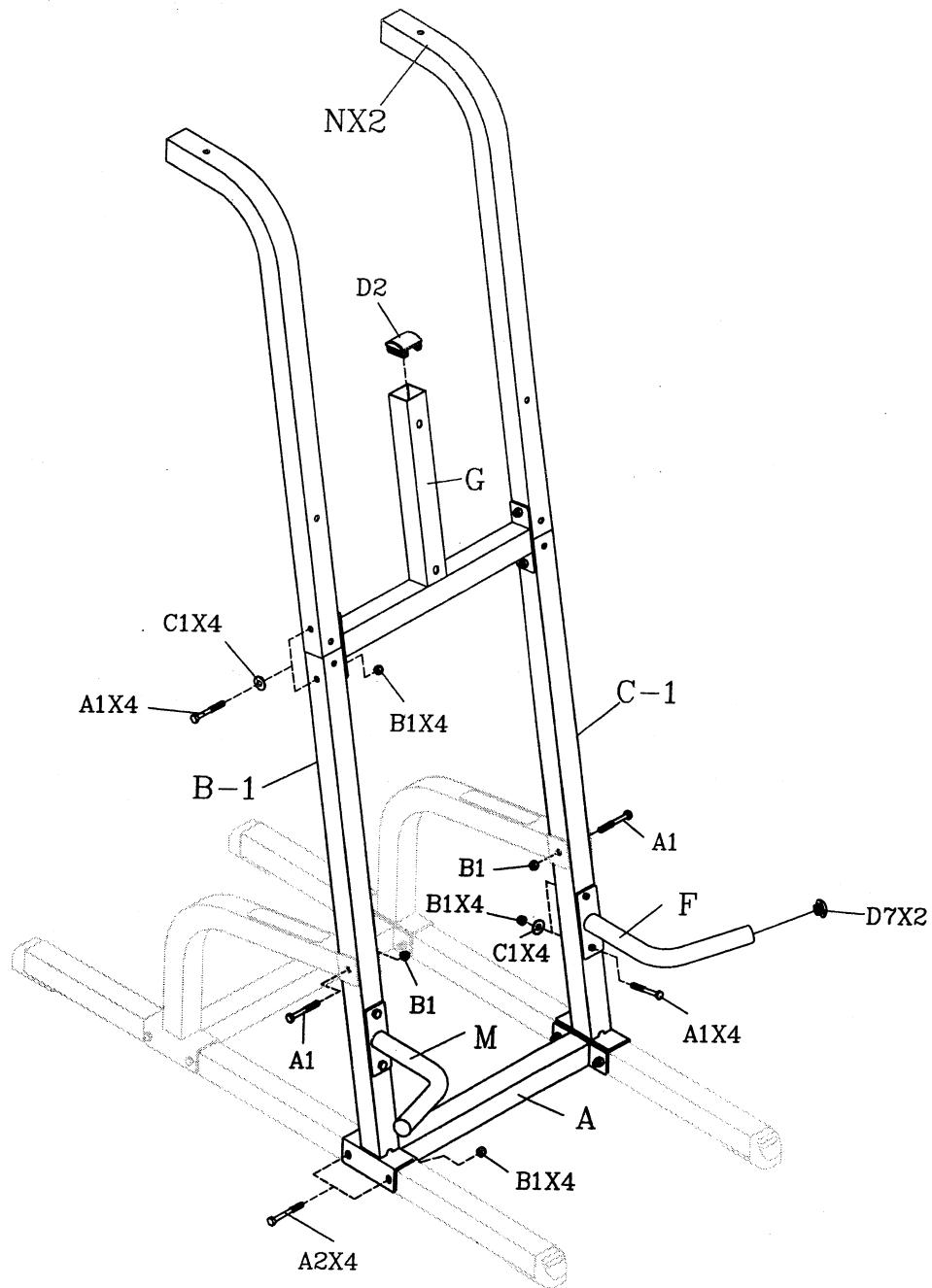

# **GVKR82 ASSEMBLY INSTRUCTIONS**

## **ASSEMBLY- STEP 3**

*\*\*Note : Do Not fully tighten frame bolts and nuts until after completing Step 3*

The following Parts and Hardware will be needed to complete Step 3

### **Parts Description**

### **Hardware Description**

| <u>Qty</u> | <u>Part</u> | <u>Part Description</u> | <u>Qty</u> | <u>Part</u> | <u>Part Description</u> |
|------------|-------------|-------------------------|------------|-------------|-------------------------|
| 2          | H-1         | Arm Pad Frame           | 8          | A1          | M10x70L hex head bolt   |
| 1          | I           | Pull Up Bar             | 6          | A3          | M8x70L hex head bolt    |
| 1          | K           | Back Pad                | 8          | B1          | M10 nylon lock nut      |
| 2          | L           | Arm Pads                | 8          | C1          | M10 ID washer           |
|            |             |                         | 6          | C2          | M8 ID washer            |
|            |             |                         | 6          | C3          | M8 spring washer        |
|            |             |                         | 4          | D2          | 2x2 end cap             |
|            |             |                         | 6          | D7          | 1" round end cap        |

### **Step by Step**

1. Attach 2 (L) - Arm Pads to 2 (H) - Arm Pad Frames
2. Attach (H) - Arm Pad Frames to (B) - Right Upright Frame, attach (H) - Arm Pad Frame to (C) - Left Upright Frame
3. Attach (I) - Pull Up Bar to (B) - Right Upright Frame and (C) - Left Upright Frame
4. Attach (K) - Back Pad to (G) - Back Pad Frame

**\*\*Securely Tighten All Frame Bolts Used in Steps 3**

# GVKR82 ASSEMBLY INSTRUCTIONS

## ASSEMBLY- STEP 3

