

Hand Sink with Tubular Supports

ASSEMBLY INSTRUCTIONS

CAUTION

INSPECT CONTENTS IMMEDIATELY AND FILE CLAIM WITH DELIVERING CARRIER FOR ANY DAMAGE. **SAVE YOUR BOX AND ALL PACKING MATERIALS.** YOU ARE RESPONSIBLE FOR DAMAGE TO YOUR UNIT IF RETURNED IMPROPERLY PACKED.

Dimensions for plumbing rough-ins:

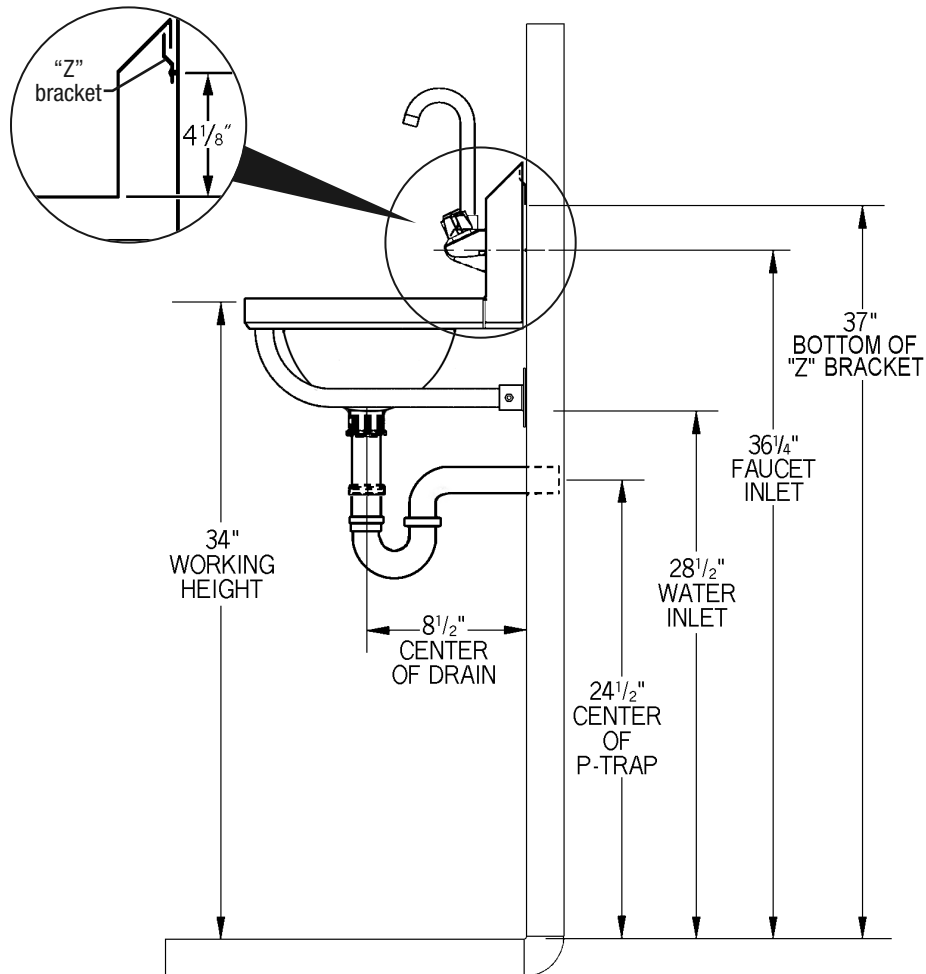

(continued on back page) 

EG9893 Revised 02/24



• 100 Industrial Boulevard, Clayton, Delaware 19938-8903 U.S.A.
• Phone: 302/653-3000 • 800/441-8440 • Fax: 302/653-2065
• www.eaglegrp.com • www.eaglemh.com

Eagle Foodservice Equipment, Eagle MHC, and SpecFAB® are divisions of Eagle Group. ©2024 by the Eagle Group

Hand Sink with Tubular Supports

ASSEMBLY INSTRUCTIONS

Please note before assembly:

- Attach faucet to hand sink per faucet instructions.
- Please follow the plumbing rough-ins (front page). All dimensions are nominal.

Step 1 - Assemble tubular supports to sink.

- Insert tubular supports into wall mounted gussets.
- Insert other end of tubular supports into gusset/plate assemblies* located underneath sink deck.

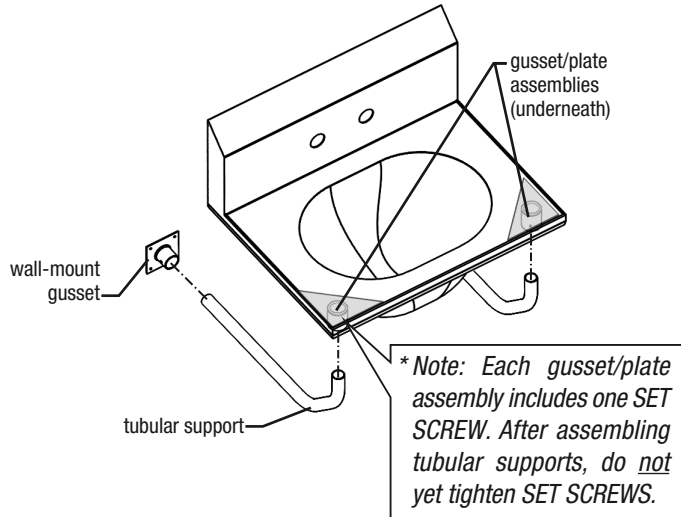

Step 2 - Mount z-bracket to wall.

Use a level for straightness.

(Note: Mounting hardware not included.)

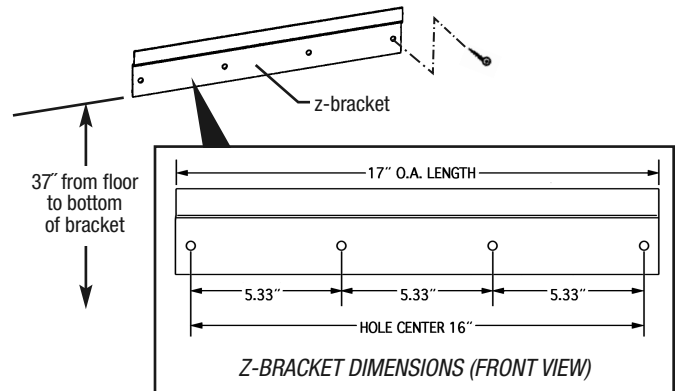

Step 3 - Hang sink off z-bracket.

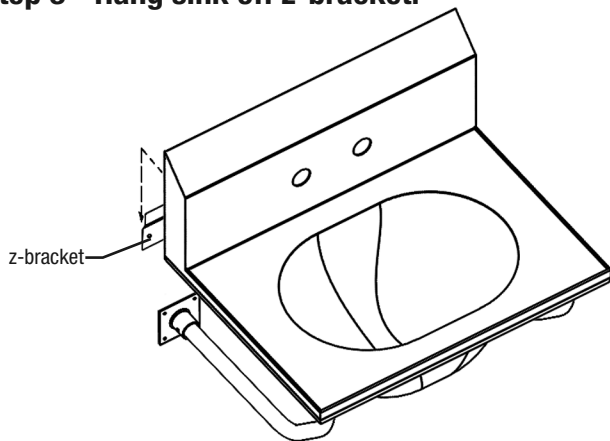

Step 4 - Secure wall-mounted gussets to wall.

(Note: Mounting hardware not included.)

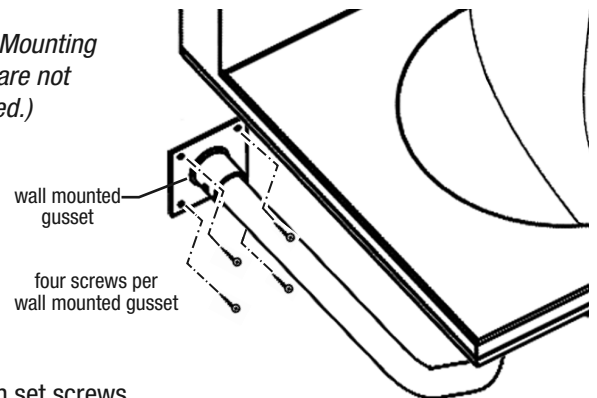

Tighten set screws of all gussets.

(End)