



## Wi-Fi® Portable Video Baby Camera with Cry Detection and Translation



### User Guide

For: PIP2000-P CONNECT

#### Important Notes:

Charge the camera unit of PIP2000-P CONNECT for 8 hours before use.

## Safety instructions

# **WARNING**

Strangulation Hazard. Children have STRANGLED in cords. Keep this cord out of the reach of children (more than 1 meter or 3 feet away). Do not remove the tags from the AC Adapters. Only use the AC Adapters provided.



## Baby Camera setup and use:

- Choose a location for the baby unit that will provide the best view of your baby in their crib.
- Place the baby unit on a flat surface, such as a dresser, desk, shelf or wall mount the unit securely with the wall mount bracket provided in the pack.
- NEVER place the baby unit or cords in the crib or within reach of the baby (the unit and cords should be more than 3 feet (1m) away).

## WARNING

This Smart Video Baby Camera is compliant with all relevant standards regarding electromagnetic fields and is, when handled as described in the User Guide, safe to use. Therefore, always read the instructions in this User Guide carefully before using the device.

- Adult assembly is required. Keep small parts away from children when assembling.
- This product is not a toy. Do not allow children to play with it.
- This baby camera is not a substitute for responsible adult supervision.
- Keep this User Guide for future reference.
- Do not place the baby (camera) unit or cords in the crib or within reach of the baby (the unit and cords should be more than 3 feet (1m) away).
- Keep the cords out of reach of children.
- Do not cover the baby camera with a towel, blanket, or other item that will stop air circulation.
- Never use extension cords with power adapters. Only use the power adapters provided.
- Test this camera and all its functions so that you are familiar with it prior to actual use.
- Do not use the baby camera near water or allow water or other foreign substances to enter the power port or adapter.
- Do not place the Baby Camera near a heat source.
- Only use the chargers and power adapters provided. Do not use other chargers or power adapters as this may damage the device and battery packs.
- Do not touch the plug contacts with sharp or metal objects.
- The unit should be set up and used so that parts of the user's body other than the hands are maintained at a distance of approximately 8 inches (20 cm) or more.
- The wall mounting height is less than 2 m for the baby unit.

# Welcome...

## to your new Smart Video Baby Camera!

Thank you for purchasing your new Smart Nursery product. Now you can see and hear your baby sleeping in another room or you can monitor your older children in their playroom.

### Important

To use your baby camera, you must be able to establish a Wi-Fi link between your baby camera and your Wi-Fi router, and the range will be affected by environmental conditions.

Any large metal object, like a refrigerator, a mirror, a filing cabinet, a metallic door or reinforced concrete between the baby camera and the Wi-Fi router may block the radio signal.

The signal strength may also be reduced by other solid structures, like walls, or by radio or electrical equipment, such as TVs, computers, cordless or mobile phones, fluorescent lights or dimmer switches.

Other 2.4GHz products, Bluetooth™ systems, microwave ovens or other baby monitors, may cause interference with this product, so keep the baby camera at least 5 ft (1.5 m) away from these types of products, or switch them off if they appear to be causing interference.

If the signal is weak, try moving the baby camera to different positions in rooms.

### Need help?

If you have any problems setting up or using your **PIP2000-P CONNECT**, please visit us at: [motorolanursery.com/support](http://motorolanursery.com/support)

Alternatively, you may find the answer in the 'Help' section at the back of this guide.

**This User Guide provides you with all the information you need to get the most from your Smart Video Baby Camera.**

**Read the instructions carefully, and be aware that this Smart Video Baby Camera is only intended as an aid. It is not a substitute for responsible and proper adult supervision.**

**Before you use the Smart Video Baby Camera, follow the simple instructions in ‘Getting started’, on the next few pages.**

### **Important**

Use only the supplied power adapter (DC5V / 2000 mA).

### **Got everything?**

- Baby (camera) unit
- AC power adapter for the baby (camera) unit
- USB-A to USB-C cable
- Wall mount bracket and screws

**If you have purchased multi camera pack, you will also have the following additional items:**

- Baby (camera) unit(s)
- AC power adapter(s) for the baby (camera) unit(s)
- USB-A to USB-C cable (s)

For Wi-Fi® internet viewing you will need a suitable Android or iPhone/iPad device and Wi-Fi® internet connection of at least 1.5 Mbps upload bandwidth per baby (camera) unit.

1.	Getting started .....	7
2.	Getting to know your baby camera .....	9
3.	Viewing the baby through your device.....	10
3.1	Minimum System Requirements.....	10
3.2	Connect your device.....	10
3.3	Set up the camera.....	10
3.3.1	Set up user account and camera on your devices.....	11
3.3.2	Connect the Camera.....	11
3.3.3	Download the app.....	11
3.3.4	Sign up or log in to the app.....	11
3.3.5	Add a camera to your account.....	11
3.3.6	Help center on the app .....	11
3.4	Cry detection and translation on your device .....	12
4.	Help.....	14
5.	Technical Specifications.....	16
6.	General information.....	17

# 1. Getting started

## Location

### Important

Do not place your **PIP2000-P CONNECT** in the bathroom or other humid areas.

Place your units within reach of the AC power outlet and wall socket. The socket-outlet should be installed near the equipment and should be easily accessible.

## Setting up

### Important

The baby (camera) unit must be plugged into the wall socket at all times. Use only the AC power adapter supplied with the product.

## Connecting the baby (camera) unit

You will need to carry out this process for the single or multi baby (camera) units.

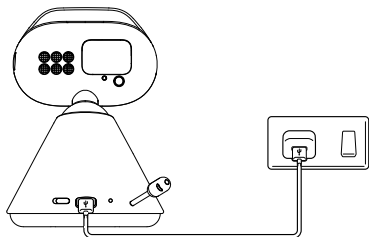

1. Plug the supplied USB cable into the USB-A socket of the AC power adapter.
2. Plug the USB cable into the USB-C socket on the side of the camera unit and plug the AC power adapter into the wall socket.
3. Switch on the AC power (if your AC power outlet has a switch) and slide the switch to ON position on the camera unit. The baby (camera) unit turns on and the power indicator lights up in blue and flashes in red after 30 seconds if paired to the Motorola Beb  App.

**Your PIP2000-P CONNECT is now ready for use.**

## 2. Getting to know your baby camera

### Overview of your baby (camera) unit

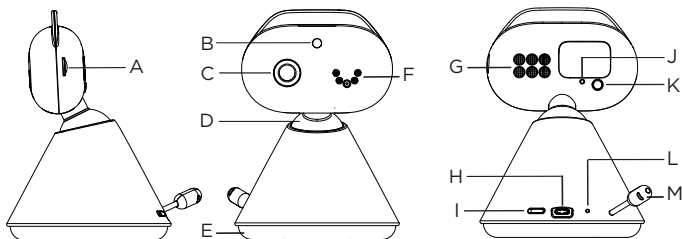

#### A SD card socket (support up to 128G SD card)

Support micro SD card. Store the video from event or live recordings.

#### B Light sensor and Infrared LEDs

The light sensor detects a low level of ambient light to activate night vision mode. The infrared LEDs around the camera and behind the black lens are ON, and the screens on your smartphone turn black and white.

#### C Camera (CMOS sensor with Infrared LEDs around)

#### D Manual pan tilt head

#### E Desk stand

#### F Microphone

It picks up the sound from the baby.

Note: Make sure you remove any cover or protective tape from it.

#### G Speaker

#### H Power jack (USB-C)

#### I Slide switch (Power On/OFF the camera unit)

#### J Power / Linking LED indicator

Lights up in blue when the baby (camera) unit is powered on and linked to the Motorola Bebé App.

It flashes red when the camera unit is not connected to the Wi-Fi routers.

It turns OFF automatically during night mode.

#### K Pair button

Press and hold to pair to the Motorola Bebé App.

#### L Battery Charging LED Indication

Lights up in red during battery charging.

It turns OFF when battery is fully charged.

Battery level is shown on the Motorola Bebé App.

#### M Temperature sensor

## Wall mount the baby (camera) unit

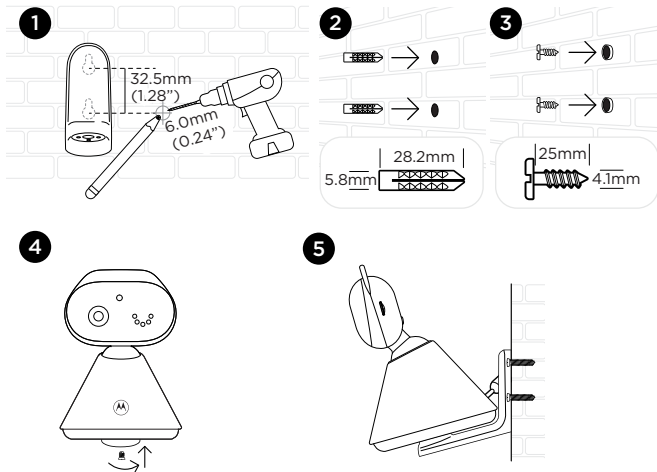

1. Place the supplied wall mount bracket on the wall and mark the positions of 2 screw holes. Drill a screw hole at each marking.
2. Install the supplied wall anchors into 2 screw holes on the wall.
3. Insert the supplied wall mounting screws into the wall anchors.
4. Fix and fasten this screw on the baby (camera) unit and the wall mount bracket.
5. Hang the wall mount bracket on the wall mounting screws on the wall.
6. Adjust the camera manually if necessary.

## 3. Viewing the baby through your device

### 3.1 Minimum System Requirements

#### Android™ System

- Version 7.0 or above

#### iPhone®/iPad® iOS

- Version 13.0 or above

#### High Speed (Wi-Fi®) Internet

- At least 1.5 Mbps upload bandwidth per camera (you can test your internet speed on this site: <http://www.speedtest.net>).

### 3.2 Connect your device

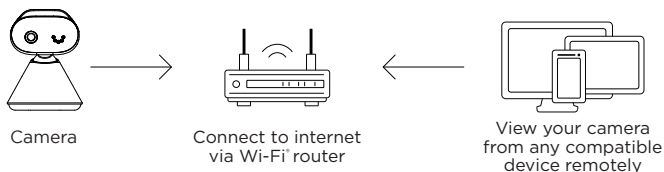

When a user tries to access the Wi-Fi® camera (baby unit), our server authenticates the user's identity and permits access to the Wi-Fi® camera (baby unit).

#### Note

You can only set up through a compatible smartphone or tablet but not through a PC.

### 3.3 Set up the camera

Connect the Wi-Fi® camera (baby unit) to the power adapter, then plug into the wall socket. The camera must be within range of the Wi-Fi® router with which you want to connect. Make sure the password of the router is available for entering during the in-app setup process.

The following table shows the meanings of different LED connection status.

State	LED indication
Pair	Flashes blue and red
Connected	Solid blue
Video streaming	Solid blue

### 3.3.1 Set up user account and camera on your devices

You will need:

- Wi-Fi® camera (baby unit)
- Power adapter for the camera
- Device with Android™ system version 7.0 and above, or
- iPhone®/iPad® with iOS version 13.0 and above
- Wi-Fi® router works at 2.4GHz or 5GHz

### 3.3.2 Connect the Camera

1. Switch off any parent unit in case you have, before connecting the camera (baby unit) to Wi-Fi®.
2. Connect the power adapter to the power outlet and insert the plug into the power socket on the back of the camera (baby unit). The camera turns on.

### 3.3.3 Download the app

1. Scan the QR code with your smart device and download the **Motorola Bébé App** from App Store for iOS devices or from Google Play™ Store for Android™ devices.



2. Install the app on your device.

### 3.3.4 Sign up or log in to the app

1. Ensure that your smart device is connected to your Wi-Fi® router.
2. Follow the on-screen instructions to run and sign up or log in to the app.

### 3.3.5 Add a camera to your account

1. Log in to the App.
2. Tap **+** on the home screen and select **Add Device** to pair a new camera.
3. Tap the device **'PIP2000-P CONNECT'**.
4. Follow the on-screen instructions to add the new camera.

### 3.3.6 Help center on the app

Should you have any queries on using the app, you can go to the Help center on the app where you can have a FAQ list or you can enter your questions.

1. Inside the camera screen, tap **---** on the right hand upper corner.
2. Scroll down and tap **'Help Center'**.

Alternatively, you can go to the **User** screen and tap **'FAQ & Feedback'**.

### 3.4 Cry detection and translation on your device



BeyondCry™ insights, powered by Zoundream™, is a feature designed to assist parents and caregivers by analysing their baby's cries and offering possible interpretations of what they may indicate, simplified into five physical states: hungry, sleepy, uncomfortable, burping, or irritated. However, it is important to remember that this feature is intended as a helpful guide only — it should never replace your own experience, intuition, or judgment as a parent or caregiver. The interpretations generated by the system are not medical advice, and Meizhou Guo Wei Electronics Co., LTD assumes no responsibility for their accuracy or any decisions made in reliance upon them. If you have concerns about your baby's health or well-being, you should consult a qualified healthcare professional.

To start using the BeyondCry™ insights feature, please download and open the Motorola Beb  app (see the "Download the App" section) and follow the in-app steps to activate it.

You can enjoy full access to BeyondCry™ insights free of charge for the first month following activation. Afterwards you can then continue using the feature by signing up for a subscription service with Zoundream™. Terms and conditions apply. Usage is calculated by calendar day; any use within a given day counts as access and activation.

Note: The BeyondCry™ feature will only work when your Baby Unit (camera) is connected to the internet.

#### 3.4.1 Set up user account to activate

- On the app, enter **PIP2000-P CONNECT** to view the live stream, tap  and then tap the BeyondCry™ icon  at the bottom.
- The app view of the Cry translation will be shown. Tap '**Activate**' and then set up the account in Zoundream's web view.

#### 3.4.2 Cry translation on the app view

After the feature is activated, your baby's cries will be detected and translated. The app view will show:

- Cry detected and translating.
- Cry translated - uncomfortable, sleepy, irritated, hungry or burp with the time stamp.
- The last translated result will be shown on the app view and it will stay there for 24 hours if no other cries are detected.
- To review the history of the cry translated, tap '**More Insights**' and go to Zoundream's web view.

When cry is detected, the following translation results will be shown on the app view:

Uncomfortable  Baby is uncomfortable

Irritated  Baby is irritated

Hungry  Baby is hungry

Sleepy  Baby is sleepy

Burp  Baby is burping

 Not possible to translate the sounds

### Note

This cry detection and translation feature will involve subscriptions. For details, please check the app.

**The translation of the baby's cry may give an idea of the baby's needs but may be incorrect. Every baby is different, every situation is different, and artificial intelligence can make mistakes. Therefore, the responsible adult supervising the baby should use their best judgement to determine the baby's needs.**

**This is not a medical device and is intended solely for non-clinical, domestic use by caregivers. It must not be used for medical decision-making, diagnostics, or in any safety-critical application. Any such use constitutes unintended use and falls outside the scope for which the system has been validated.**

## 4 Help

### **No display (only for models with parent unit)**

- Try recharging the battery pack.
- Reset the parent and baby (camera) units. Unplug the baby unit from the wall socket, then plug it back in. Press and hold the power button to reset the parent unit.
- Check if the parent/baby (camera) unit is powered on.
- Press and hold the power button on the parent unit to switch it on.
- Make sure the correct camera is selected. Change the camera number if necessary.
- Make sure the display of the parent unit is turned on.
- When operating using batteries only, the display will go blank after 5 minutes, 15 minutes or 30 minutes to save power (depending on video settings). The parent unit is still active and will give you audio alerts. You can press any button to reactivate the screen.

### **The baby (camera) unit has lost its link with the parent unit (only for models with parent unit).**

- The baby (camera) unit is too far away and may be out of range. Move the it closer to the parent unit.
- Power reset both the parent and baby (camera) units. Wait for about 15 seconds and reconnect them. Allow up to one minute for the parent and baby (camera) units to synchronize.
- Re-register your baby (camera) unit if necessary, see page 13.

### **Noise interference on your device**

- The baby and parent units may be too close with each other. Move them further apart (only for models with parent unit).
- Make sure there is at least (2 meters) 6 feet between the parent and baby (camera) units to avoid audio feedback (only for models with parent unit).
- The baby (camera) unit is too far away and may be out of range. Move it closer to the parent unit. (only for models with parent unit)
- Make sure the parent and baby (camera) units are not placed near other electrical equipment, such as a television, computer or cordless/mobile telephone. Move the parent and baby (camera) units 1.5 meters (5 feet) away from other electrical equipment. (only for models with parent unit)
- Use of other 2.4 GHz products, such as Bluetooth™ systems or microwave ovens, may cause interference with this product. Keep the parent and baby (camera) units at least 1.5 meters (5 feet) away from these types of products, or switch them off if they appear to be causing interference. (only for models with parent unit)
- If the signal is weak, try moving the parent and/or baby (camera) units to different positions in rooms.

## Lost connection to your smart device

- Check your Wi-Fi® settings and power reset your Wi-Fi router if necessary. Power reset the baby (camera) unit. Wait for a few minutes for the baby (camera) unit to connect with the Wi-Fi® system.



## System reset

- When problems cannot be fixed based on the above guides, you can try to do a system reset. Note that after system reset, you will need to do the pairing to the app again.
- System reset for the parent unit: right under the USB socket on the parent unit, there is a small hole. Use a small pin to insert and press into it. The parent unit will go through a system reset. (only for models with parent unit)
- System reset of the camera unit: press and hold  on the camera for about 15 seconds. The voice prompt 'Ready for pairing' will be heard first. Do not release until you hear a beep. Within 3 seconds, short press it twice and you will hear the voice prompt 'Reset Camera'. The camera has now been reset successfully.

## Maintenance reset

- The camera will occasionally enter maintenance reset, there may be loss link beeps heard. If the loss link beeps do not stop, this may be caused by being at the limiting edge of the range/interference, please try to move the parent unit close to the camera unit.

## No event notification on the app

- On the camera screen, tap  and then tap 'Features'. Check if the motion detection, sound detection and temperature detection are enabled.
- On the camera screen, tap  and then tap . Check if this feature is activated.

## Talk back does not work

Please check the phone settings to see if it allows the app to access the microphone. If not, please enable it.

For more support, you can reach us at [motorolanursery.com/support](https://motorolanursery.com/support) or call +1-800-763-2207 (United States and Canada, Monday - Friday, [8:00AM - 6:00PM CT]). For questions on the app, you can also reach us at the "Help center" on the app described in the section 3.3.6.

## 5. Technical Specifications

RF frequency bands	2400 MHz to 2483.5 MHz 5150 MHz to 5850 MHz
RF transmission power	< 20dBm (only for CE)
Power adapter for the camera units	Input: 100-240V AC 50/60Hz, 0.35A Output: DC5V 2.0A

Operating temperature: 0°C to 40°C

- Camera power off: short press the pair button 5 times. You will hear a beep to confirm the camera is powered off.
- Camera power on: short press the pair button when the camera power is off.

### Accuracy of the cry translation:

Age	Accuracy	Notes
0-3 months	89-92%	Newborn cries are mostly instinctive and consistent (for hunger, sleep, or comfort), so translation is most accurate at this stage.
3-6 months	87-90%	Cries start to include more variation as babies grow and develop, but accuracy remains high.
6-9 months	~ 81%	Babies use more complex sounds and vocalizations, so translations may be less precise, though still helpful for identifying common needs.

### Key influencing factors:

- Data volume and diversity: Largest dataset for 0-3 months; smaller for 3-6 months; limited for 6-9 months. Expansion ongoing.
- Developmental changes: Cry patterns become more complex after 6 months.
- Environmental noise: System optimized for typical home conditions; excessive noise can reduce performance.

Note: Real-world testing reflects conservative conditions with realistic noise and varied inputs, which is why practical accuracy may be slightly lower than controlled research figures.

The outcomes are generated using AI. They are based on statistical inference, and while designed for relevance and consistency, they are not deterministic or guaranteed to be correct.

### WARNING

- Use only with provided power adapters as tabulated in the above.

### Note

Specifications are subject to change without prior notice.

## 6. General information

### Cleaning and care

#### Important

Always switch off and disconnect the power adapter before cleaning your video baby monitor.

- Clean your video baby monitor with a slightly damp cloth or with an anti-static cloth. Never use cleaning agents or abrasive solvents.
- Do not clean any part of the video baby monitor with thinners or other solvents and chemicals - this may cause permanent damage to the product which is not covered by the warranty.
- Keep your video baby monitor away from hot, humid areas or strong sunlight, and do not let it get wet.
- Every effort has been made to ensure high standards of reliability of your Video Baby Monitor. However, if something does go wrong, please do not try to repair it yourself - contact Customer Service for assistance.

### Product Disposal Instructions

#### Product disposal instructions for residential users

When you have no further use for it, please remove any batteries and dispose of them and the product according to your local authority's recycling processes. For more information, please contact your local authority or the retailer where the product was purchased.



#### Product disposal instructions for business users

Business users should contact their suppliers and check the terms and conditions of the purchase contract and ensure that this product is not mixed with other commercial waste for disposal.

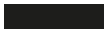

### Consumer Products and Accessories Warranty

Thank you for purchasing this Motorola branded product manufactured under license by Meizhou Guo Wei Electronics Co. LTD., AD1 Section, The Economic Development Area, Meizhou, 514000, Guangdong Province, China ("MZGW").

#### What Does this Warranty Cover?

Subject to the exclusions contained below, MZGW warrants that this Motorola branded product ("Product") or certified accessory ("Accessory") sold for use with this product that it manufactured to be free from defects in materials and workmanship under normal consumer usage for the period outlined below. This Limited Warranty is your exclusive warranty and is not transferable.

#### Who is covered?

This warranty extends only to the first consumer purchaser, and is not transferable.

## What will MZGW do?

MZGW or its authorized distributor at its option and within a commercially reasonable time, will at no charge repair or replace any Products or Accessories that do not conform to this limited warranty. We may use functionally equivalent reconditioned / refurbished / pre-owned or new Products, Accessories or parts.

## What Other Limitations Are There?

ANY IMPLIED WARRANTIES, INCLUDING WITHOUT LIMITATION THE IMPLIED WARRANTIES OF MERCHANTABILITY AND FITNESS FOR A PARTICULAR PURPOSE, SHALL BE LIMITED TO THE DURATION OF THIS LIMITED WARRANTY, OTHERWISE THE REPAIR OR REPLACEMENT PROVIDED UNDER THIS EXPRESS LIMITED WARRANTY IS THE EXCLUSIVE REMEDY OF THE CONSUMER, AND IS PROVIDED IN LIEU OF ALL OTHER WARRANTIES, EXPRESS OF IMPLIED. IN NO EVENT SHALL MOTOROLA OR MZGW BE LIABLE, WHETHER IN CONTRACT OR TORT (INCLUDING NEGLIGENCE) FOR DAMAGES IN EXCESS OF THE PURCHASE PRICE OF THE PRODUCT OR ACCESSORY, OR FOR ANY INDIRECT, INCIDENTAL, SPECIAL OR CONSEQUENTIAL DAMAGES OF ANY KIND, OR LOSS OF REVENUE OR PROFITS, LOSS OF BUSINESS, LOSS OF INFORMATION OR OTHER FINANCIAL LOSS ARISING OUT OF OR IN CONNECTION WITH THE ABILITY OR INABILITY TO USE THE PRODUCTS OR ACCESSORIES TO THE FULL EXTENT THESE DAMAGES MAY BE DISCLAIMED BY LAW.

Some jurisdictions do not allow the limitation or exclusion of incidental or consequential damages, or limitation on the length of an implied warranty, so the above limitations or exclusions may not apply to you. This warranty gives you specific legal rights, and you may also have other rights that vary from one jurisdiction to another.

Products Covered	Length of Coverage
<b>Consumer Products</b>	<b>One (1) year</b> from the date of the products original purchase by the first consumer purchaser of the product.
<b>Consumer Accessories (battery, power supply(s) and line cords)</b>	<b>Ninety (90) days</b> from the date of the accessories original purchase by the first consumer purchaser of the product.
<b>Consumer Products and Accessories that are Repaired or Replaced</b>	<b>The balance of the original warranty or for ninety (90) days</b> from the date returned to the consumer, whichever is longer.

## Exclusions

**Normal Wear and Tear.** Periodic maintenance, repair and replacement of parts due to normal wear and tear are excluded from coverage.

**Batteries.** Only batteries whose fully charged capacity falls below 80% of their rated capacity and batteries that leak are covered by this limited warranty.

**Abuse & Misuse.** Defects or damage that result from: (a) improper operation, storage, misuse or abuse, accident or neglect, such as physical damage (cracks, scratches, etc.) to the surface of the product resulting from misuse; (b) contact with liquid, water, rain, extreme humidity or heavy perspiration, sand, dirt or the like, extreme heat, or food; (c) use of the Products or Accessories for commercial purposes or subjecting the Product or Accessory to abnormal usage or conditions; or (d) other acts which are not the fault of Motorola or MZGW are excluded from coverage.

**Use of Non-Motorola branded Products and Accessories.** Defects or damage that result from the use of Non-Motorola branded or certified Products or Accessories or other peripheral equipment are excluded from coverage.

**Unauthorized Service or Modification.** Defects or damages resulting from service, testing, adjustment, installation, maintenance, alteration, or modification in any way by someone other than Motorola, MZGW or its authorized service centers, are excluded from coverage.

**Altered Products.** Products or Accessories with (a) serial numbers or date tags that have been removed, altered or obliterated; (b) broken seals or that show evidence of tampering; (c) mismatched board serial numbers; or (d) nonconforming or non-Motorola branded housings, or parts, are excluded from coverage.

**Communication Services.** Defects, damages, or the failure of Products or Accessories due to any communication service or signal you may subscribe to or use with the Products or Accessories is excluded from coverage.

### **How to Obtain Warranty Service or Other Information?**

To obtain service or information, please visit us at:

[motorolanursery.com/support](http://motorolanursery.com/support)

You will receive instructions on how to ship the Products or Accessories at your expense and risk, to a MZGW Authorized Repair Center.

To obtain service, you must include: (a) the Product or Accessory; (b) the original proof of purchase (receipt) which includes the date, place and seller of the Product; (c) if a warranty card was included in your box, a completed warranty card showing the serial number of the Product; (d) a written description of the problem; and, most importantly; (e) your address and telephone number.

### **EU Declaration of Conformity (DoC)**

Hereby, Meizhou Guo Wei Electronics Co. LTD declares that the product is in compliance with RE Directive 2014/53/EU. The full text of the EU declaration of conformity is available on the website: [motorolanursery.com](http://motorolanursery.com).

### **UK Declaration of Conformity (DoC)**

Hereby, MZGW declares that this product is in compliance with the requirements for UKCA marking. The Declaration of Conformity can be obtained at [motorolanursery.com](http://motorolanursery.com).

## FCC and IC regulations

### FCC Caution:

Any changes or modifications not expressly approved by the party responsible for compliance could void the user's authority to operate the equipment.

This device complies with part 15 of the FCC Rules. Operation is subject to the following two conditions: (1) This device may not cause harmful interference, and (2) this device must accept any interference received, including interference that may cause undesired operation.

### IMPORTANT NOTE:

Note: This equipment has been tested and found to comply with the limits for a Class B digital device, pursuant to part 15 of the FCC Rules. These limits are designed to provide reasonable protection against harmful interference in a residential installation. This equipment generates, uses and can radiate radio frequency energy and, if not installed and used in accordance with the instructions, may cause harmful interference to radio communications. However, there is no guarantee that interference will not occur in a particular installation. If this equipment does cause harmful interference to radio or television reception, which can be determined by turning the equipment off and on, the user is encouraged to try to correct the interference by one or more of the following measures:

- Reorient or relocate the receiving antenna.
- Increase the separation between the equipment and receiver.
- Connect the equipment into an outlet on a circuit different from that to which the receiver is connected.
- Consult the dealer or an experienced radio/TV technician for help.

## ISED Warning

This device complies with Innovation, Science, and Economic Development Canada licence-exempt RSS standard(s). Operation is subject to the following two conditions:

- (1) this device may not cause interference, and
- (2) this device must accept any interference, including interference that may cause undesired operation of the device.

Le présent appareil est conforme aux CNR d'Innovation, Sciences et Développement économique Canada applicables aux appareils radio exempts de licence. L'exploitation est autorisée aux deux conditions suivantes :

- (1) l'appareil ne doit pas produire de brouillage, et
- (2) l'utilisateur de l'appareil doit accepter tout brouillage radioélectrique subi, même si le brouillage est susceptible d'en compromettre le fonctionnement.

The device for operation in the band 5150–5250 MHz is only for indoor use to reduce the potential for harmful interference to co-channel mobile satellite systems.

Operation of 5250-5350 MHz is restricted to indoor use only.

L'appareil destiné à fonctionner dans la bande 5150–5250 MHz est uniquement destiné à une utilisation en intérieur afin de réduire le risque d'interférence nuisible aux systèmes mobiles par satellite utilisant le même canal.

Le fonctionnement de la bande 5250-5350 MHz est limité à une utilisation en intérieur uniquement.

### **Radiation Exposure Statement:**

The baby unit complies with FCC/ISED radiation exposure limits set forth for an uncontrolled environment. The baby unit should be installed and operated with minimum distance 20cm between the radiator& your body.

### **Déclaration d'exposition aux radiations:**

L'unité bébé est conforme aux limites d'exposition aux rayonnements FCC/ ISED établies pour un environnement non contrôlé. L'unité bébé doit être installée et utilisée avec une distance minimale de 20 cm entre le radiateur et votre corps.

**Manufactured by:**

Meizhou Guo Wei Electronics Co., Ltd.

**Factory address:**

AD1 Section, The Economic Development Area, Meizhou, 514000,  
Guangdong Province, China

**USA address:**

16192 Coastal Highway, Lewes, Delaware, 19958, County of Sussex, USA

**UK address:**

207 Regent Street, Suite 8, Third Floor, London, W1B 3HH. UK

**EU address:**

51 Bracken Road, Carlisle Offices, Dublin 18, D18 CV48. Ireland

**Contact email address:**

support@motorolanursery.com

Manufactured, distributed or sold by Meizhou Guo Wei Electronics Co. LTD., official licensee for this product. MOTOROLA and the Stylized M Logo are trademarks or registered trademarks of Motorola Trademark Holdings, LLC. and are used under license. All other trademarks are the property of their respective owners. © 2026 Motorola Mobility LLC. All rights reserved.

Version 7.0 (EN)



*Séparez les éléments avant de trier*



Points de collecte sur [www.quefairede mesdechets.fr](http://www.quefairede mesdechets.fr)  
Privilégiez la réparation ou le don de votre appareil !

