

Use and Care Guide

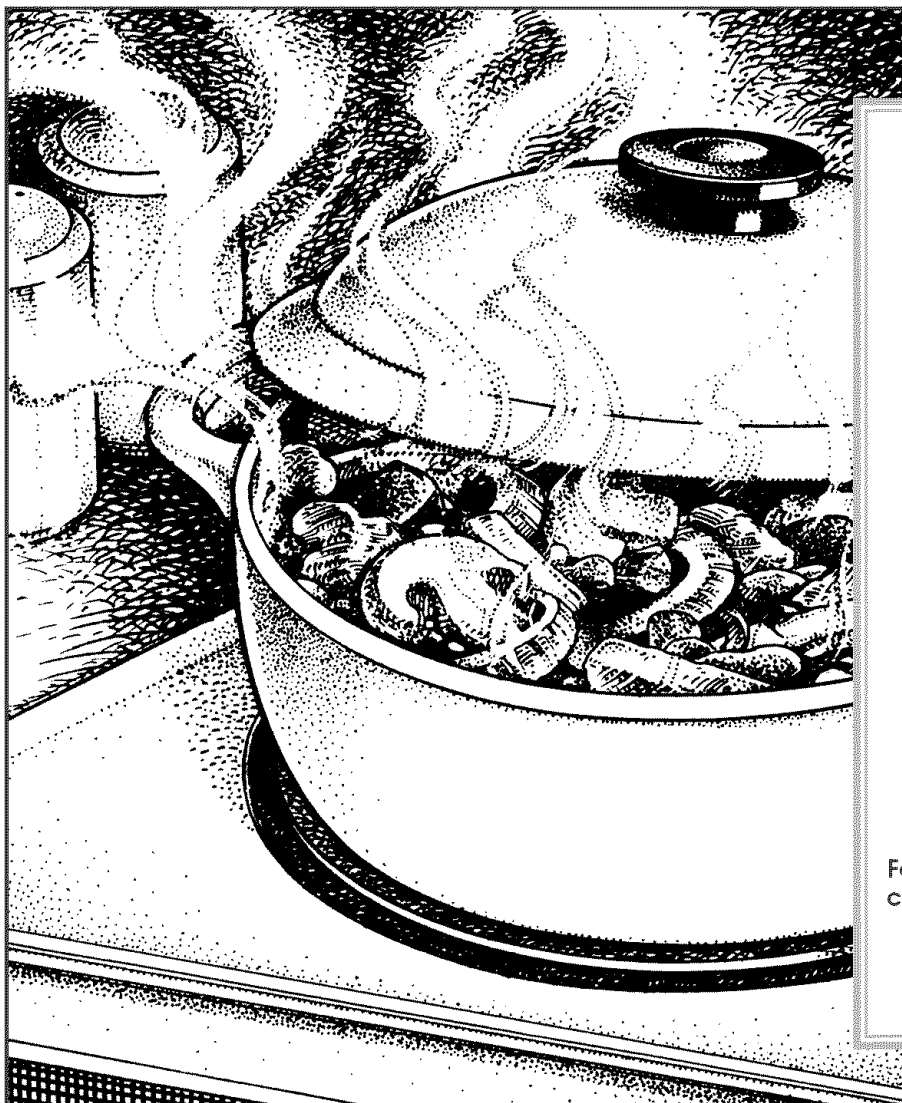

KitchenAid®
FOR THE WAY IT'S MADE®

Table of Contents	2
A Note to You	2
Cooktop Safety	3
Using Your Cooktop	5
Caring For Your Cooktop	13
Troubleshooting	17
Requesting Assistance or Service	18
Warranty	20

For assistance or service in the U.S.A.,
call the Consumer Assistance Center.

For assistance or service
in Canada, see page 19.

KITCHENAID® Gas Sealed Burner Cooktop

MODELS KGCR055G KGCT055G KGCS105G KGCS127G KGCS166G
KGCT305G KGCT365G KGCT366G

Table of Contents

A Note to You	2	Caring for Your Cooktop.....	13
Cooktop Safety	3	Cleaning chart.....	13
Using Your Cooktop	5	Stainless steel surfaces	14
Using the Surface Burners.....	5	Sealed surface burners and cooktop ..	15
Characteristics of cookware materials	12	Troubleshooting.....	17
		Requesting Assistance or Service.....	18
		Warranty	20

A Note to You

Thank you for buying a KITCHENAID® appliance!

Because your life is getting busier and more complicated, KitchenAid appliances are easy to use, save time, and help you manage your home better. To ensure that you enjoy many years of trouble-free operation, we developed this Use and Care Guide. It contains valuable information concerning how to operate and maintain your new appliance properly and safely. Please read it carefully. Also, please complete and mail the enclosed Product Registration Card.

Please record your model's information.

Whenever you call our Consumer Assistance Center at **1-800-422-1230** (in Canada, **1-800-461-5681**) or request service for your appliance, you need to know your complete model number and serial number. You can find this information on the model and serial number plate (see illustration on pages 6-10 for location of plate).

Please also record the purchase information.

Model Number _____

Serial Number _____

Purchase/
Installation Date _____

Builder/Dealer
Name _____

Address _____

Phone _____

NOTE: You must provide proof of purchase or installation date for in-warranty service.

Keep this book and the sales slip together in a safe place for future reference.

Cooktop Safety

Your safety and the safety of others is very important.

We have provided many important safety messages in this manual and on your appliance. Always read and obey all safety messages.



This is the safety alert symbol.

This symbol alerts you to hazards that can kill or hurt you and others.

All safety messages will be preceded by the safety alert symbol and the word "DANGER" or "WARNING." These words mean:

⚠ DANGER

You will be killed or seriously injured if you don't follow instructions.

⚠ WARNING

You can be killed or seriously injured if you don't follow instructions.

All safety messages will identify the hazard, tell you how to reduce the chance of injury, and tell you what can happen if the instructions are not followed.

WARNING: If the information in this manual is not followed exactly, a fire or explosion may result causing property damage, personal injury or death.

- Do not store or use gasoline or other flammable vapors and liquids in the vicinity of this or any other appliance.
- WHAT TO DO IF YOU SMELL GAS
 - Do not try to light any appliance.
 - Do not touch any electrical switch; do not use any phone in your building.
 - Immediately call your gas supplier from a neighbor's phone. Follow the gas supplier's instructions.
 - If you cannot reach your gas supplier, call the fire department.
- Installation and service must be performed by a qualified installer, service agency or the gas supplier.

continued on next page



IMPORTANT SAFETY INSTRUCTIONS

WARNING: To reduce the risk of fire, electrical shock, injury to persons, or damage when using the cooktop, follow basic precautions, including the following:

- **CAUTION** – Do not store items of interest to children in cabinets above the cooktop – children climbing on the cooktop to reach items could be seriously injured.
- **Proper Installation** – The cooktop, when installed, must be electrically grounded in accordance with local codes or, in the absence of local codes, with the *National Electrical Code, ANSI/NFPA 70* or the *Canadian Electrical Code, Part 1*. Be sure the cooktop is properly installed and grounded by a qualified technician.
- This cooktop is equipped with a three-prong grounding plug for your protection against shock hazard and should be plugged directly into a properly grounded receptacle. Do not cut or remove the grounding prong from this plug.
- Disconnect the electrical supply before servicing the cooktop.
- Never Use the Cooktop for Warming or Heating the Room.
- Injuries may result from the misuse of the cooktop such as stepping, leaning, or sitting on the top surface.
- Maintenance – Keep cooktop area clear and free from combustible materials, gasoline, and other flammable vapors and liquids.
- Storage on the cooktop – Flammable materials should not be stored on or near surface units.
- Top burner flame size should be adjusted so it does not extend beyond the edge of the cooking utensil.

– SAVE THESE INSTRUCTIONS –

Using Your Cooktop

Using the surface burners

Your cooktop has sealed gas burners with an electric ignition system. The sealed burners spread the heat evenly across the bottom of the cookware and provide infinite heat control.

IMPORTANT: Your cooktop is factory-set for use with Natural Gas. If you wish to use L.P. gas, an L.P. Gas Conversion Kit is provided with the unit. The conversion must be done by a qualified service technician.

Surface Grates

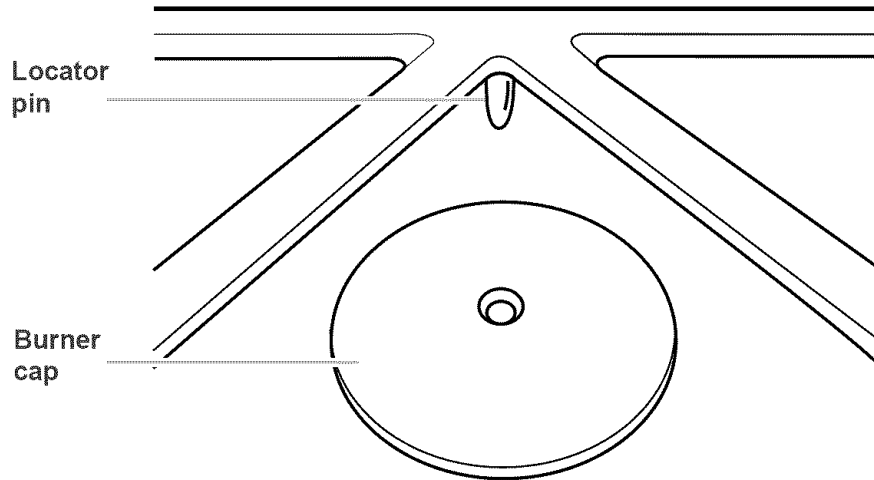

The locator pin on the grate must be positioned in the burner cap hole to hold the grate in place.

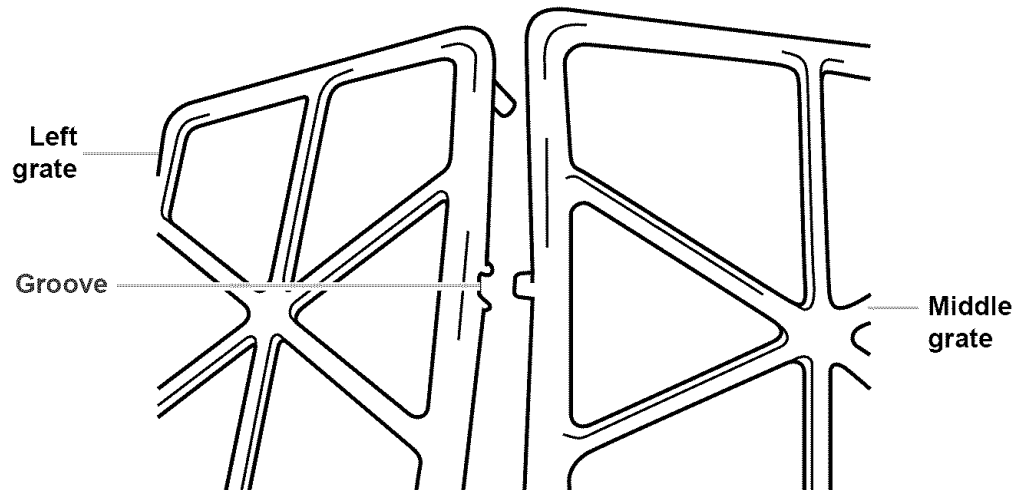

The grates located on the left and right side of the cooktop contain grooves. These grooves must always face inward toward the control knobs to hold the grates in place.

NOTE: The middle grate must be placed in position first followed by the left and right grates (see pp. 7-10 for illustration)

Using Your Cooktop

Models KGCT055G (15 inch/38.1 cm)
KGCR055G (15 inch/38.1 cm)-not shown

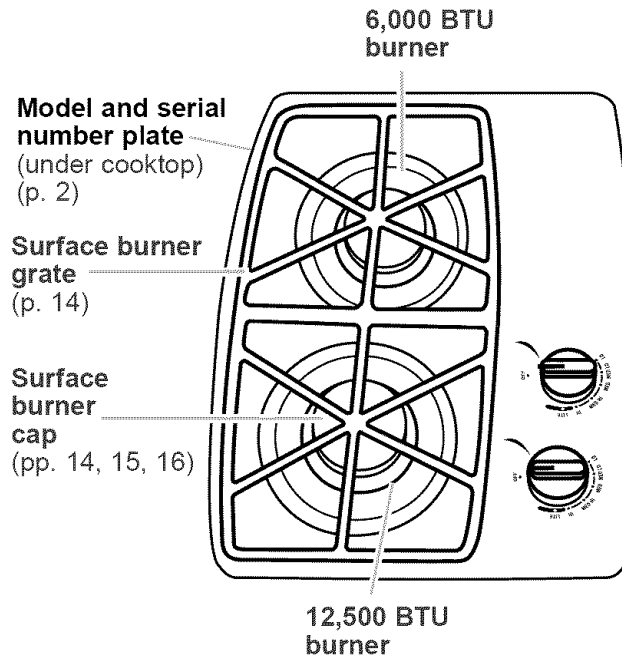

Use the rear burner for simmering or for cooking smaller quantities of food requiring small cookware.
Use the front burner for cooking large quantities of food, deep-fat frying, or cooking with large cookware.

Control panel

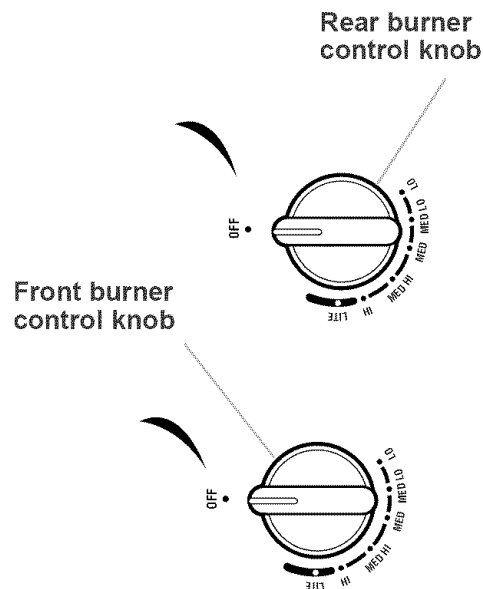



Model KGCT365G (36 inch/91.4 cm)

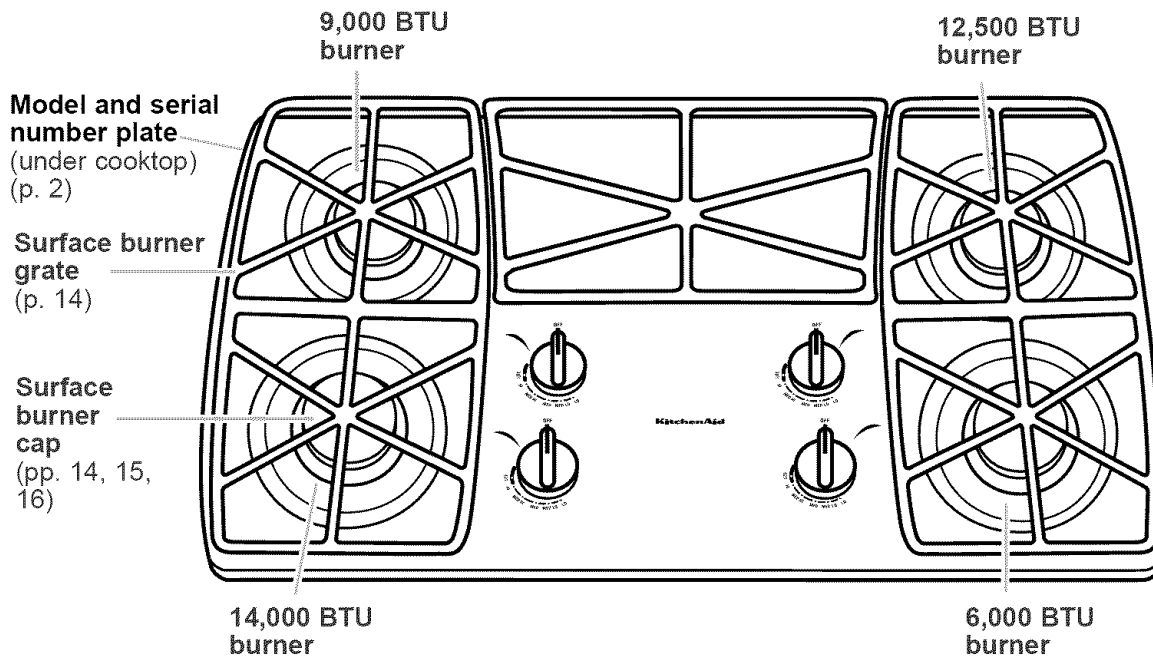

Use the left rear and right front burners for simmering or for cooking smaller quantities of food requiring small cookware.
 Use the left front and right rear burners for cooking large quantities of food, deep-fat frying or cooking with large cookware.

Control panel

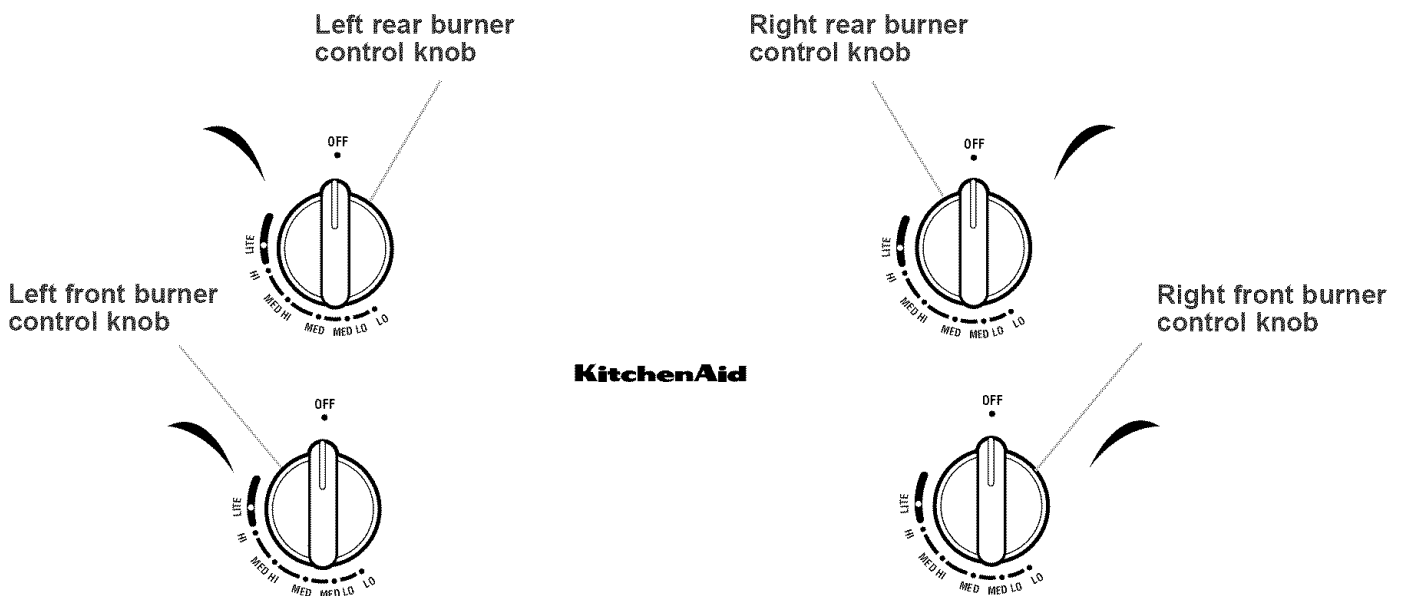



Using Your Cooktop

Models KGCS105G (30 inch/76.2 cm)
KGCT305G (30 inch/76.2 cm)

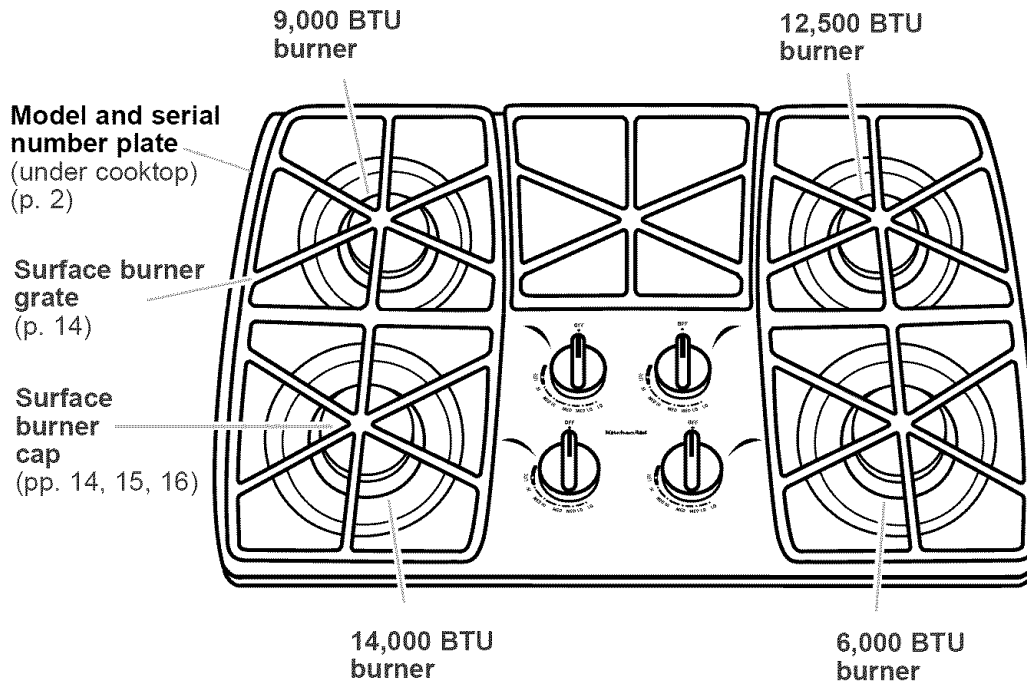

Use the left rear and right front burners for simmering or for cooking smaller quantities of food requiring small cookware.

Use the left front and right rear burners for cooking large quantities of food, deep-fat frying, or cooking with large cookware.

Control panel

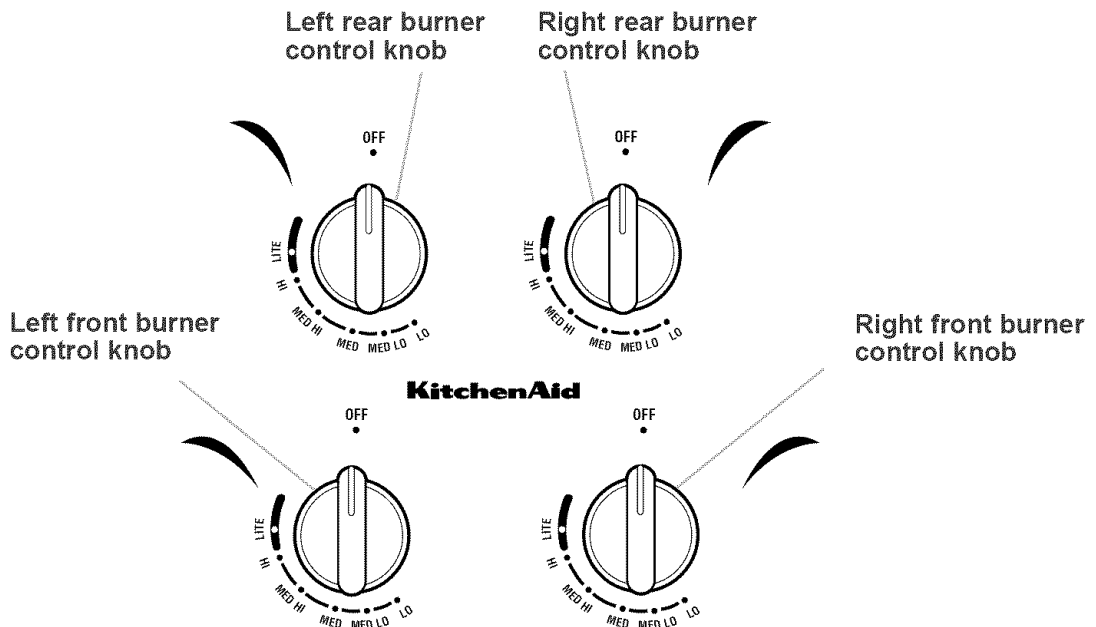

**Models KGCS166G (36 inch/91.4 cm)
KGCT366G (36 inch/91.4 cm)**

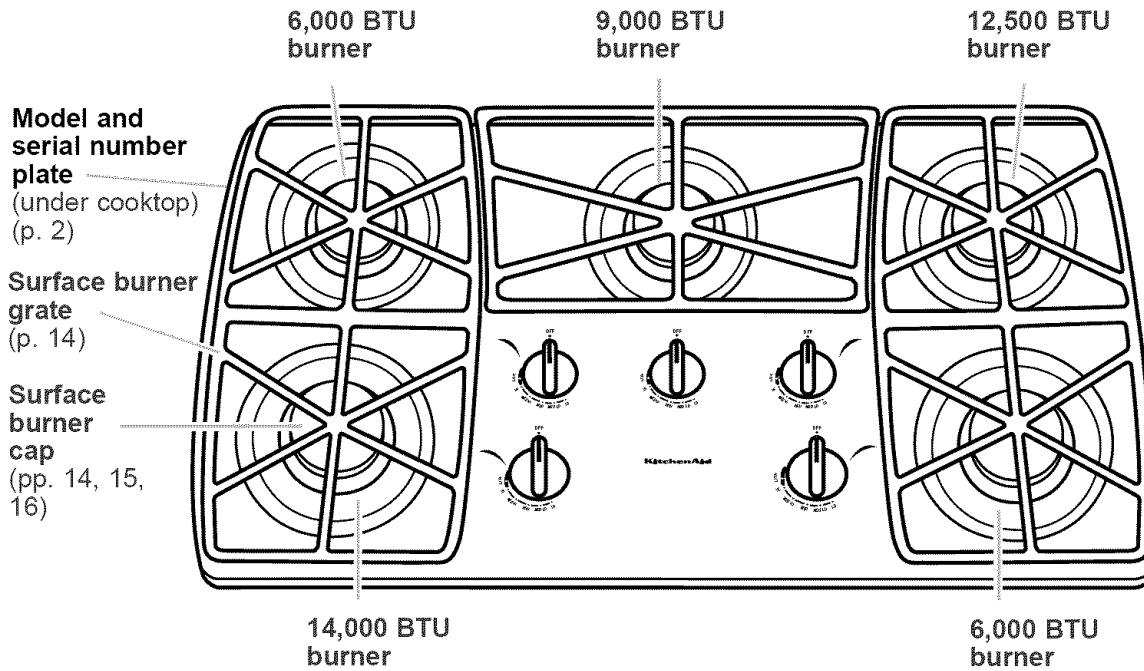

Use the left rear, center, or right front burners for simmering or for cooking smaller quantities of food requiring small cookware.

Use the left front and right rear burners for cooking large quantities of food, deep-fat frying or cooking with large cookware.

Control panel

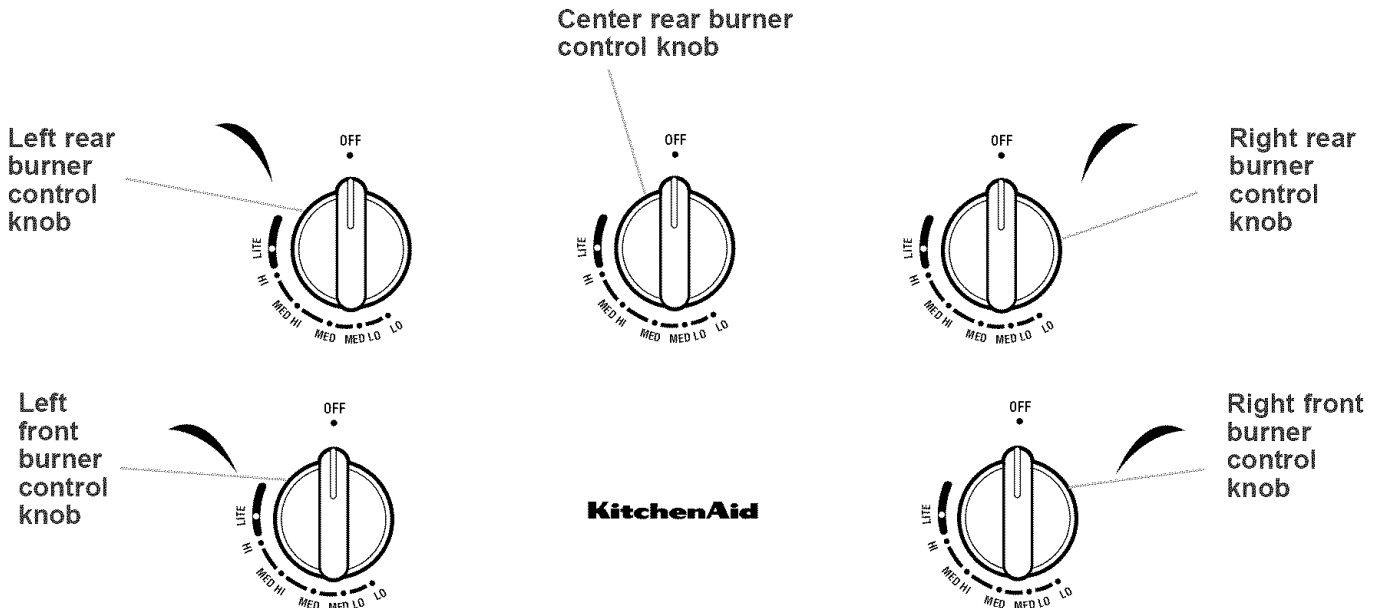



Using Your Cooktop

Model KGCS127G (43 inch/109 cm)

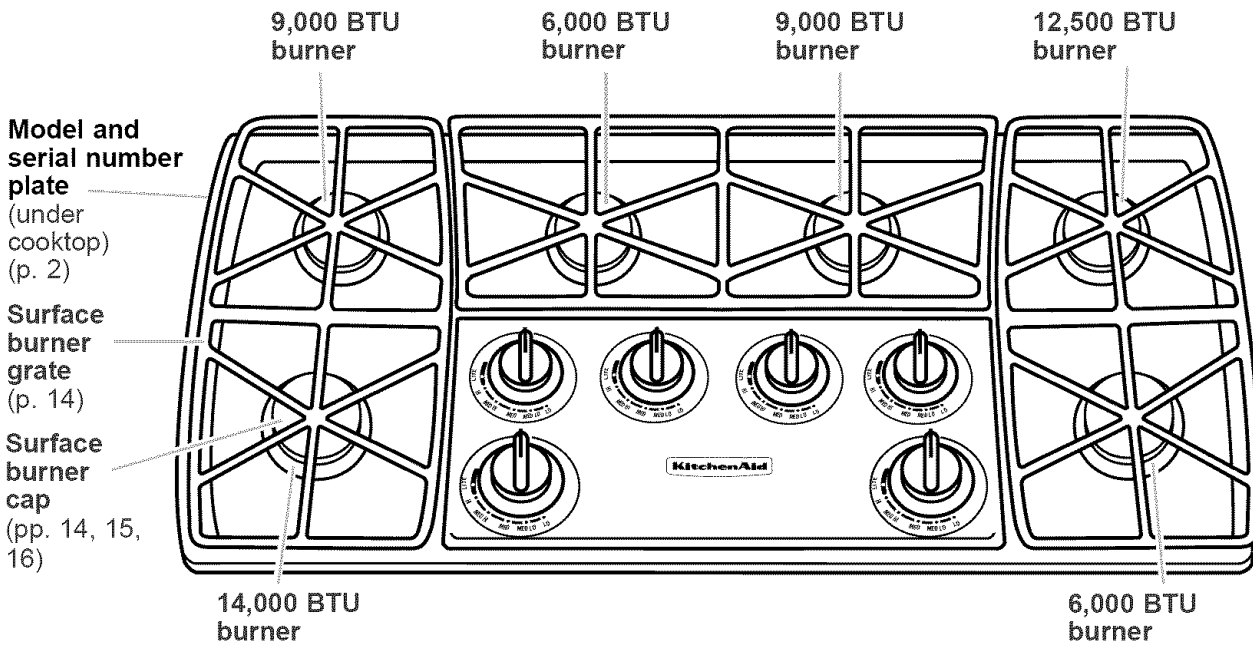

Use the left rear, center left rear, center right rear, or right front burners for simmering or for cooking small-quantity quantities of food requiring small cookware.

Use the left front or right rear burners for cooking large quantities of food, deep-fat frying, or cooking with large cookware.

Control panel

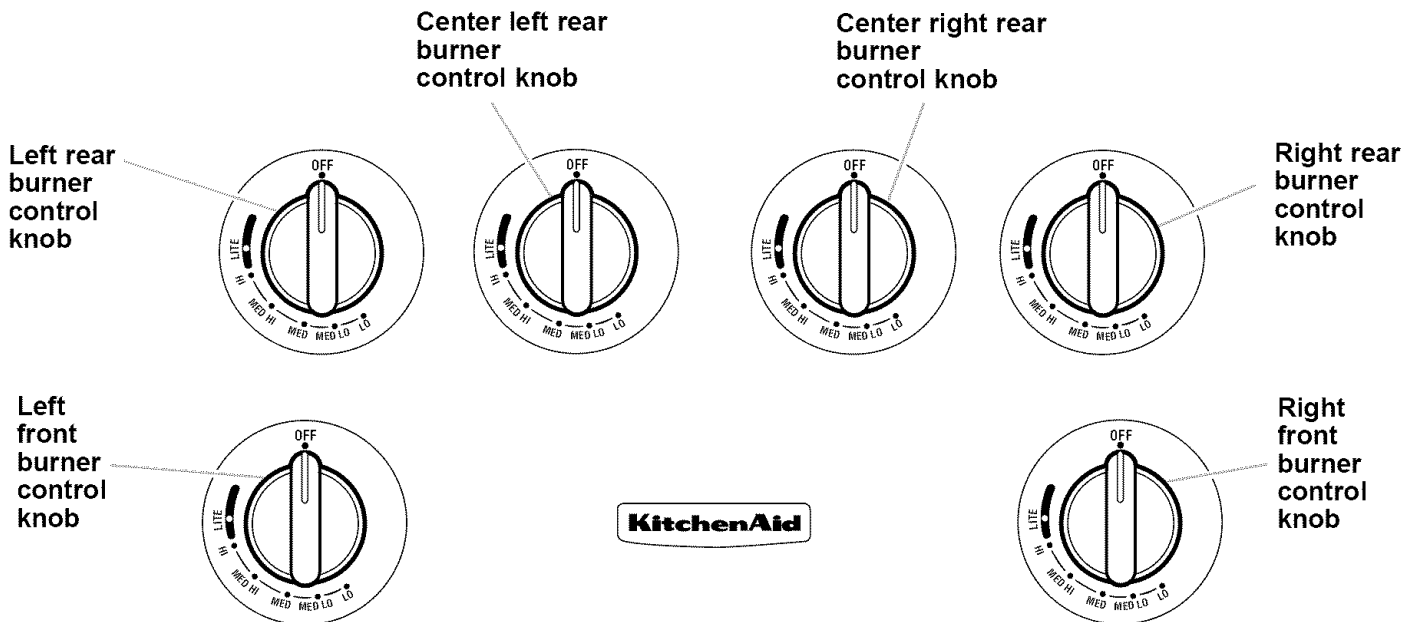

Using the Surface Burners (cont.)

Using the control knobs

Your cooktop comes with electric ignitors. Electric ignitors automatically light the burners each time you turn the control knobs to LITE.

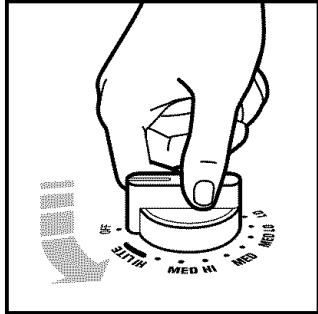

- Place a filled pan on the burner grate before turning on the surface burner. Do not operate a burner for extended periods of time without having cookware on the grate.

- Push in the control knob and turn it **counter-clockwise** to the LITE position. The clicking sound is the ignitor sparking. Make sure the burner has lit.
- To stop the clicking sound after the burner lights, turn the control knob to the cook setting you want. You can set the control knob anywhere between HI and LO.

NOTE: All electric ignitors will click at the same time. However, the burner with the control knob turned to LITE is the one that will ignite.

!WARNING



Fire Hazard

Do not let the burner flame extend beyond the edge of the pan.

Turn off all controls when not cooking.

Failure to follow these instructions can result in death or fire.

NOTE: Do not leave empty cookware, or cookware which has boiled dry, on a hot surface burner. The cookware could overheat causing damage to the cookware or cooking product.

Burner heat settings

Use the following chart as a guide.

SETTING	RECOMMENDED USE
LITE	• To light the burner.
HI	• To start food cooking. • To bring liquid to a boil.
MED HI	• To hold a boil. • To fry chicken or pancakes.
MED	• For gravy, pudding, and icing. • To cook large amounts of vegetables.
MED LO	• To keep food cooking after starting it on a higher setting.
LO	• To keep food warm. • To melt chocolate or butter. • To simmer.

Energy saving tips

- To help shorten your cooking time, use the least amount of liquid possible.
- Preheat your pans only when recommended and for the shortest time possible.
- Start your food on a higher heat setting, then turn the control to a lower setting to finish cooking.

Using the Surface Burners (cont.)

In case of a prolonged power failure

You can manually light surface burners. Hold a lit match near a burner and turn the control knob to the LITE position. After the burner lights, turn the control knob to the setting you want.

Home canning information

The large diameter of most water-bath or pressure canners combined with high heat settings for long periods of time can cause damage to the cooktop.

To protect your cooktop:

- Center the canner over the surface burner. Do not extend more than 1 inch outside the burner area.
- Do not place your canner on two surface burners at the same time.
- Start with hot water, cover with a lid and bring to a boil; then reduce heat to maintain a boil or required pressure levels in a pressure canner.

- Refer to your canner manual for specific instructions.

For up-to-date information on canning, contact your local U.S. Government Agricultural Department Extension Office or companies who manufacture home canning products.

Using the right cookware makes a big difference

- The pan should have a flat bottom, straight sides, and a well-fitting lid.
- Choose medium to heavy gauge (thickness) cookware.
- The pan material (metal or glass) affects how quickly and evenly the pan heats.
- When using glass or ceramic cookware, check to make sure it is suitable for use on surface burners.
- To avoid tipping, make sure pots and pans are centered on the grates.

Characteristics of cookware materials

The pan material affects how fast heat transfers from the surface cooking area through the pan material and how evenly heat spreads over the pan bottom. Choose pans that provide the best cooking results.

Aluminum	<ul style="list-style-type: none"> • Heats quickly and evenly. • Use for all types of cooking. • Medium or heavy thickness is best for most cooking. • Used as a core or base in cookware to provide even heating.
Cast iron	<ul style="list-style-type: none"> • Heats slowly and evenly. • Good for browning and frying. • Maintains heat for slow cooking. • Can be coated with porcelain enamel.
Ceramic or ceramic glass	<ul style="list-style-type: none"> • Heats slowly and unevenly. • Use on low to medium settings. • Follow manufacturer's instructions.
Copper	<ul style="list-style-type: none"> • Heats very quickly and evenly. • Used as a core or base in cookware to provide even heating.
Earthenware	<ul style="list-style-type: none"> • Can be used for cooktop cooking if recommended by the manufacturer. • Use on low settings.
Porcelain enamel-on-steel or enamel-on-cast iron	<ul style="list-style-type: none"> • See cast iron and stainless steel.
Stainless steel	<ul style="list-style-type: none"> • Heats quickly but unevenly. • A core or base of aluminum or copper on the cookware provides even heating. • Can be coated with porcelain enamel.

Caring for Your Cooktop

Your cooktop is designed so you can care for it easily. You can do most cleaning with items found around your home. Cleaning your cooktop whenever spills or soiling occurs will help to keep it looking and working like new.

	! WARNING
	<p>Explosion Hazard</p> <p>Do not store flammable materials such as gasoline near this appliance. Doing so can result in death, explosion, or fire.</p>

Cleaning chart

Before cleaning, always make sure all controls are off and the cooktop is cool. Refer to instructions on all cleaning products before using them to clean your cooktop.

PART	CLEANING METHOD	SPECIAL INSTRUCTIONS
Control Knobs	<ul style="list-style-type: none"> • Soap and water • Dishwasher 	<ul style="list-style-type: none"> • DO NOT use steel wool or abrasive cleaners. • Pull knobs straight away from control panel. • Wash, rinse and dry with soft cloth.
Control Panel	<ul style="list-style-type: none"> • Soap and water • Spray glass cleaner 	<ul style="list-style-type: none"> • Wash, rinse and dry with soft cloth. • Apply spray cleaner to paper towel; do not spray directly on panel.
Cooktop Surface	<ul style="list-style-type: none"> • Soap and water • Mild liquid cleaner • Spray glass cleaner • Non-abrasive plastic scrubbing pad 	<ul style="list-style-type: none"> • DO NOT use abrasive or harsh cleaners like chlorine bleach, ammonia or oven cleaners. • Wash, rinse and dry with soft cloth. • Gently clean around the model and serial plate, too much scrubbing could remove the numbers. • NOTE: To avoid product damage, do not remove the cooktop.

* When the cooktop is cool, remove all spills and clean. Food spills containing acids, such as vinegar and tomato, may affect the finish.

Cleaning chart (cont.)

PART	CLEANING METHOD	SPECIAL INSTRUCTIONS
Surface burner grates and caps* <ul style="list-style-type: none"> • Light to moderate soil • Heavy burned on soils 	<ul style="list-style-type: none"> • Soap and water • Non-abrasive plastic scrubbing pad • Dishwasher (grates only) • Non-abrasive plastic scrubbing pad • Mild abrasive powdered cleanser and water 	<ul style="list-style-type: none"> • Clean as soon as they become dirty. • Wash, rinse and dry well. • Repeat steps of cleaning process (with items at left) as needed, until soil is completely removed. • Rinse thoroughly and dry. • NOTE: Do not reassemble caps on burners while wet. Do not wash caps in dishwasher.
Surface burners		<ul style="list-style-type: none"> • See “Sealed surface burners and cooktop” in the “Caring for your cooktop” section.

Stainless steel surfaces (some models)

Cleaning Stainless Steel Surfaces <ul style="list-style-type: none"> • Do not use steel wool or soap-filled scouring pads • Rub in the direction of the grain line to avoid marring surface • Always wipe dry to avoid water marks • If commercial cleaners are used, follow label directions. If product contains chlorine (bleach), rinse thoroughly and dry with a soft, lint-free cloth. Chlorine is a corrosive substance. 		
	CLEANING AGENT	HOW TO USE
Routine cleaning and fingerprints	• Liquid detergent and water; all-purpose cleaner	• Wipe with damp cloth or sponge, then rinse with clean water and wipe dry.
Stubborn stains and baked-on residue	• Mild-abrasive cleanser or stainless steel cleaners	• Rub in the direction of the grain lines with a damp cloth or sponge and cleaner. Rinse thoroughly. Repeat if necessary.
Hard water spots	• Vinegar	• Swab or wipe with cloth. Rinse with water and dry.

Sealed surface burners and cooktop

Cleaning the surface burners

- You should routinely remove and clean the burner caps. Always clean the burner caps after a spillover. Keeping the burner caps clean prevents improper ignition and an uneven flame.
- For the proper flow of gas and ignition of the burner, **DO NOT ALLOW SPILLS, FOOD, CLEANING AGENTS, OR ANY OTHER MATERIAL TO ENTER THE GAS TUBE OPENING.**
- Gas must flow freely through the gas tube opening for the burner to light properly. You must keep this area free of any soil and protect it from boilovers or spillovers. **ALWAYS** keep the burner cap in place whenever a surface burner is in use.
- Let the cooktop cool before cleaning.
- Do not use oven cleaners, bleach, or rust removers.
- Do not obstruct the flow of combustion and ventilation air.
- If the knobs are removed while cleaning, be careful not to spill liquids through the holes in the control area.
- Be careful not to allow moisture to collect in the control area. Moisture can cause the ignitor switches to fail.

Cast-iron burner cap

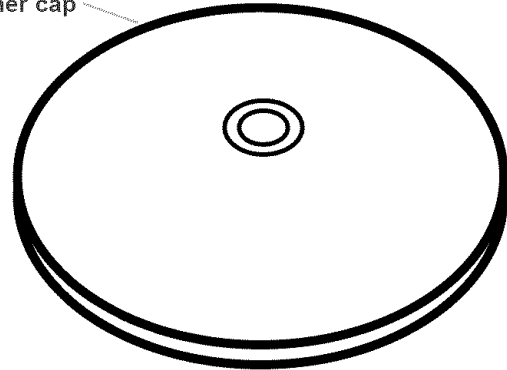

Alignment pins

Ignitor

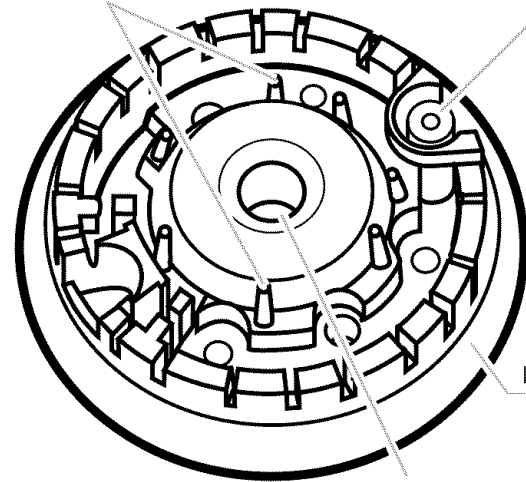

Burner base

Gas tube opening

- Occasionally check the burner flames for proper size and shape as shown. A good flame is blue in color. If the flames are uneven, you may need to clean the burners.

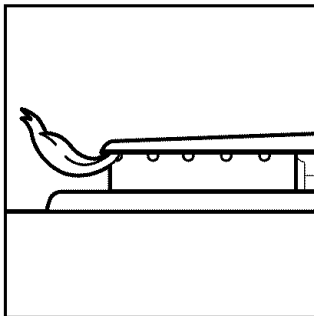

Sealed surface burners and cooktop (cont.)

To clean the burners:

1. Pull the burner caps straight up from the burner base.
2. Clean the burner caps with warm, soapy water and a sponge. You can also clean the caps with a mildly abrasive plastic scrubbing pad and powdered cleanser. Do not clean the burner caps in a dishwasher or self-cleaning oven.
3. If the gas tube opening has become soiled or clogged, use a cotton swab or a soft cloth to clean the area.
4. If the ports are clogged, clean them with a straight pin. Do not enlarge or distort the port. Do not use a wooden toothpick. If the burner needs to be adjusted, call a qualified technician for service.

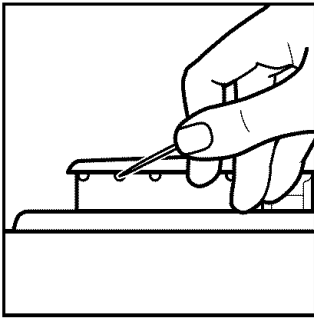

5. After cleaning the gas tube opening and ports, replace the burner caps. To replace the burner caps, make sure the alignment pins on the burner base are properly aligned with the cap.

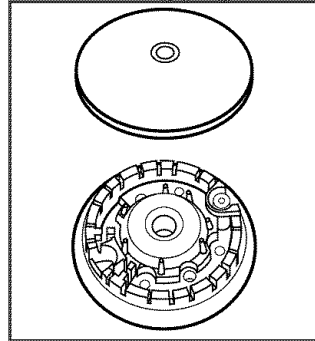

6. Turn on the burner to see if it will light. If the burner does not light after you have cleaned it, contact an authorized KitchenAid service technician. Do not service the sealed burner yourself.

Troubleshooting

You can solve many common cooktop problems easily, saving you the cost of a possible service call. Try the suggestions below to see if you can solve your problem without outside help. If the suggestions do not work, see “Requesting Assistance or Service” on page 18 (In the U.S.A.), or on page 19 (in Canada).

Problem	Problem Cause	Solution
Nothing will operate.	<ul style="list-style-type: none"> • The cooktop is not wired into a live circuit with proper voltage. • The cooktop is not properly connected to the gas supply. • A household fuse has blown or a circuit breaker has tripped. • A control knob is not set correctly. 	<ul style="list-style-type: none"> • Wire the cooktop into a live circuit with proper voltage. (See installation instructions.) • Contact an authorized KitchenAid service technician to reconnect the cooktop to the gas supply. • Replace household fuse or reset circuit breaker. • Push in the control knobs before turning them.
The burner fails to light.	<ul style="list-style-type: none"> • A household fuse has blown or a circuit breaker has tripped. • The burner is wet from being washed. • The burner ports may be clogged. 	<ul style="list-style-type: none"> • Replace household fuse or reset circuit breaker. • Let it dry. • Clean them with a straight pin. (See page 16.)
<p>The burner flames are uneven.</p> <p>The burner flames lift off the ports, are yellow, or are noisy when turned off.</p>	<ul style="list-style-type: none"> • The burner ports may be clogged. • The burner needs cleaning. • The air/gas mixture is incorrect. 	<ul style="list-style-type: none"> • Clean them with a straight pin. (See page 16.) • Clean as directed on page 16. • Contact an authorized KitchenAid service technician to check the air/gas mixture or see Installation Instructions.
Cooking results are not what you expected.	<ul style="list-style-type: none"> • The cooktop is not level. • The pan used is not the correct type or size. • The flame size does not fit the cookware being used. • The flow of combustion and/or ventilation air to the cooktop is blocked. 	<ul style="list-style-type: none"> • Level the cooktop. • Refer to a reliable cookbook for recommended pan type and size. • Pan should be the same size or slightly larger than surface cooking are being used. • Remove any obstructions around knobs or burners.

Requesting Assistance or Service

Before calling for assistance or service, please check the “Troubleshooting Guide” section. It may save you the cost of a service call. If you still need help, follow these instructions.

If you need assistance or service in the U.S.A.:

Call the KitchenAid Consumer



Assistance Center toll free: 1-800-422-1230.
Our consultants are available to assist you.

When calling:

Please know the purchase date, and the complete model and serial number of your appliance (see the “A Note to You” section). This information will help us to better respond to your request.

Our consultants provide assistance with:

- Features and specifications on our full line of appliances.
- Installation information.

- Use and maintenance procedures.
- Accessory and repair parts sales.
- Specialized customer assistance (Spanish speaking, hearing impaired, limited vision, etc.).
- Referrals to local dealers, service companies, and repair parts distributors.

KitchenAid service technicians are trained to fulfill the product warranty and provide after-warranty service, anywhere in the United States.

To locate the authorized KitchenAid service company in your area, you can also look in your telephone directory Yellow Pages.

If you need replacement parts

If you need to order replacement parts, we recommend that you only use factory authorized parts. These parts will fit right and work right, because they are made with the same precision used to build every new KITCHENAID® appliance.

To locate factory authorized replacement parts in your area, call our Consumer Assistance Center telephone number or your nearest authorized service center.

For further assistance

If you need further assistance, you can write to KitchenAid with any questions or concerns at:

KitchenAid Brand Home Appliances
Consumer Assistance Center
c/o Correspondence Dept.
2000 North M-63
Benton Harbor, MI 49022-2692

Please include a daytime phone number in your correspondence.

If you need assistance or service in Canada:

Call the KitchenAid Consumer



Assistance Center toll free:
8:30 a.m. - 6 p.m. (EST) at
1-800-461-5681. Our consul-
tants are available to assist
you.

When calling:

Please know the purchase date, and the complete model and serial number of your appliance (see the "A Note to You" section). This information will help us to better respond to your request.

Our consultants provide assistance with:

- Features and specifications on our full line of appliances.

- Accessory and repair parts sales.
- Specialized customer assistance (French speaking, hearing impaired, limited vision, etc.).
- Referrals to local dealers, service companies, and repair parts distributors.

KitchenAid service technicians are trained to fulfill the product warranty and provide after-warranty service, anywhere in Canada.

To locate the authorized KitchenAid service company in your area, you can also look in your telephone directory Yellow Pages.

KitchenAid Canada Appliance Service – Consumer Services

Direct service branches:

BRITISH COLUMBIA		1-800-665-6788
ALBERTA		1-800-661-6291
ONTARIO (except 807 area code)	Ottawa area Outside the Ottawa area	1-800-267-3456 1-800-807-6777
MANITOBA, SASKATCHEWAN and 807 area code in ONTARIO		1-800-665-1683
QUEBEC	Montreal (except South Shore) South Shore Montreal Quebec City Sherbrooke	1-800-361-3032 1-800-361-0950 1-800-463-1523 1-800-567-6966
ATLANTIC PROVINCES		1-800-565-1598

If you need replacement parts

If you need to order replacement parts, we recommend that you only use factory authorized parts. These parts will fit right and work right, because they are made with the same precision used to build

every new KITCHENAID® appliance. To locate factory authorized replacement parts in your area, call our Consumer Assistance Center telephone number or your nearest authorized service center.

For further assistance

If you need further assistance, you can write to KitchenAid with any questions or concerns at:

Consumer Relations Department
KitchenAid Canada
1901 Minnesota Court
Mississauga, Ontario L5N3A7

Please include a daytime phone number in your correspondence.

KitchenAid® Gas Cooktop Warranty

LENGTH OF WARRANTY:	KITCHENAID WILL PAY FOR:	KITCHENAID WILL NOT PAY FOR:
ONE-YEAR FULL WARRANTY FROM DATE OF PURCHASE.	Replacement parts and repair labor costs to correct defects in materials or workmanship. Service must be provided by an authorized KitchenAid servicing outlet.	A. Service calls to: 1. Correct the installation of the cooktop. 2. Instruct you how to use the cooktop. 3. Replace house fuses or correct house wiring. 4. Correct house plumbing. B. Repairs when cooktop is used in other than normal home use.
SECOND-THROUGH FIFTH-YEAR LIMITED WARRANTY FROM DATE OF PURCHASE.	Replacement parts for any gas burner to correct defects in materials or workmanship.	C. Damage resulting from accident, alteration, misuse, abuse, fire, flood, acts of God, improper installation, or installation not in accordance with local electrical or plumbing codes. D. Any labor costs during the limited warranties. E. Replacement parts or repair labor costs for units operated outside the United States and Canada. F. Pickup and delivery. This product is designed to be repaired in the home. G. Repairs to parts or systems resulting from unauthorized modifications made to the appliance. H. In Canada, travel or transportation expenses for customers who reside in remote areas.

8/98

KITCHENAID AND KITCHENAID CANADA DO NOT ASSUME ANY RESPONSIBILITY FOR INCIDENTAL OR CONSEQUENTIAL DAMAGES. Some states or provinces do not allow the exclusion or limitation of incidental or consequential damages, so this exclusion or limitation may not apply to you. This warranty gives specific legal rights and you may also have other rights which vary from state to state or province to province.

Outside the United States and Canada, a different warranty may apply. For details, please contact your authorized KitchenAid dealer.

If you need assistance or service, first see the "Troubleshooting" section in this book. After checking "Troubleshooting," additional help can be found by checking the "Requesting Assistance or Service" section. In the U.S.A., call our Consumer Assistance Center at **1-800-422-1230**. In Canada, call KitchenAid Canada at one of the telephone numbers listed in the "Requesting Assistance or Service" section.

