

ARG30|ARG30LP|ARG36|ARG36LP|ARG36W|ARG36WLP|ARG36B|ARG36BLP

ARG MODELS

COOK LIKE A GOD

THOR
K I T C H E N[®]

USE & CARE MANUAL

USE AND CARE MANUAL

GAS RANGES

ARG MODELS

ARG30 | ARG30LP

ARG36 | ARG36LP

ARG36W | ARG36WLP

ARG36B | ARG36BLP

THOR
K I T C H E N[®]

TABLE OF CONTENTS

| | |
|--|-----------|
| 1. WARNINGS | 3 |
| 2. WELCOME | 4 |
| 3. BEFORE YOU START | 5 |
| 4. SAFETY AND WARNINGS | 6 |
| Safety Symbols..... | 6 |
| Electrical Shock Hazard..... | 7 |
| Tipping Hazard..... | 7 |
| Explosion Hazard..... | 8 |
| Fire Hazard..... | 8 |
| Poisoning Hazard..... | 9 |
| Hot Surface Hazard..... | 9 |
| Other Safety Tips..... | 9 |
| 5. GAS SUPPLY REQUIREMENTS | 12 |
| Safety Tips For Gas Operation..... | 12 |
| 6. DIMENSIONS AND CLEARANCES | 13 |
| Btu Design..... | 13 |
| Gas Range Dimensions..... | 14 |
| Gas Range Clearance..... | 15 |
| 7. ELECTRIC POWER SUPPLY REQUIREMENTS | 16 |
| 8. ELECTRICAL GROUNDING INSTRUCTIONS | 17 |
| 9. CONNECT RANGE TO GAS SUPPLY | 17 |
| After Installation..... | 18 |
| 10. FIRST USE | 19 |
| Conditioning The Oven..... | 19 |
| 11. COOKTOP SAFETY GUIDELINES | 19 |
| Surface Burner Ignition..... | 20 |
| Simmer And Boil..... | 21 |
| Flame Size..... | 21 |
| Power Failure | 21 |
| Cooktop..... | 21 |
| Burner Grates..... | 22 |
| 12. OPERATING THE OVEN | 23 |
| Oven Cooking Safety Guidelines..... | 23 |
| Oven Function..... | 24 |
| Using The Option Function..... | 24 |
| Clock..... | 25 |
| Temp Unit..... | 25 |
| Sound On/Off..... | 25 |
| Temp Calibration..... | 25 |
| 12 hrs Safety Shutoff..... | 25 |

TABLE OF CONTENTS

| | |
|---|-----------|
| Cooking Modes Bake..... | 26 |
| Conv. Bake | 26 |
| Conv. Roast | 27 |
| Pizza | 27 |
| Warm | 28 |
| Broil | 28 |
| 13. CLEANING INSTRUCTIONS | 29 |
| Do'S..... | 29 |
| Don'ts..... | 29 |
| Cleaning Burner Caps And Flame Spreaders | 29 |
| Cleaning Oven Shelves | 30 |
| Cleaning Broil/Roast Pan | 30 |
| Cleaning Bake And Broil Burners | 30 |
| Cleaning Porcelain Surfaces | 30 |
| Cleaning The Oven Glass Window | 30 |
| Cleaning The Oven Door Gasket | 31 |
| Cleaning Stainless Steel Surfaces | 31 |
| 14. REMOVING AND REPLACING THE OVEN DOOR | 32 |
| Removing The Oven Door | 32 |
| Replacing The Oven Door | 33 |
| 15. TROUBLESHOOTING GUIDE | 34 |
| Cooktop | 34 |
| Oven | 36 |
| Information code | 37 |
| 16. WARRANTY & SERVICE | 38 |

1. WARNINGS

These are the most critical warnings summarized below.

WARNING: If the information in these instructions is not followed exactly, a fire or explosion may result causing property damage, personal injury or death.

Do not store or use gasoline or other flammable vapors and liquids in the vicinity of this or any other appliance.

WHAT TO DO IF YOU SMELL GAS

- Do not try to light any appliance.
- Do not touch any electrical switch.
- Do not use any phone in your building.
- Immediately call our gas supplier from a neighbor's phone.

Follow the gas supplier's instructions.

- If you cannot reach your gas supplier, call the fire department.

Installation and service must be performed by a qualified installer, service agency or the gas supplier.

WARNING:

Never Operate the Top Surface Cooking Section of this Appliance Unattended

- Failure to follow this warning statement could result in fire, explosion, or burn hazard that could cause property damage, personal injury, or death.
- If a fire should occur, keep away from the appliance and immediately call your fire department.

DO NOT ATTEMPT TO EXTINGUISH AN OIL/GREASE FIRE WITH WATER.

WELCOME

2. Welcome

Thank you for purchasing Thor range. We appreciate your business and we recommend that you read this entire User's Manual before operating your new appliance for the first time.

This manual contains instructions on how to properly install and set up your new range, as well as insights into the unique features that our product offers. Please keep this manual for future reference, as it contains answers to questions that you might have as you begin to cook.

Thank you, Thor Group

This manual applies to the following models' series:



**ARG30、ARG30LP、ARG36、ARG36LP、ARG36W、ARG36WLP、
ARG36B、ARG36WLP**

3. Before you start

- Make sure that the anti-tip of the range has been interoperability.
- Find the model and serial numbers on the CSA label in the bottom right-hand corner of the backboard. Note these numbers down for future reference in the space provided in section 'Warranty and service'.
- Read this guide, taking special note of the 'Safety and warnings' section.
- Remove all the packaging from the oven(s) and cook top. Recycle items that you can. If any adhesive residue is left on surfaces, remove this using dish washing liquid on a soft cloth. Do not use any harsh or abrasive cleaners.
- Make sure you follow the instructions under 'First use' before using your range cooking.
- To reduce the risk of fire, electrical shock, injury to persons, or damage when strengthen appliance, follow the important safety instructions limp-wristed:

SAFETY AND WARNINGS

4. Safety and Warnings

| SYMBOL | DEFINITION |
|--|--|
|  | <p>This will alert you to potential personal or property safety hazards. Obey all safety rules to avoid any property damage, personal injury or death.</p> |
|  WARNING | <p>WARNING: indicates a potentially hazardous situation, which, if not avoided, could result in serious injury or death.</p> |
|  CAUTION | <p>CAUTION: indicates a moderate hazardous situation, which, if not avoided, could result in minor or moderate injury.</p> |
| CAUTION | <p>CAUTION: when used without the safety alert symbol, indicates a potentially hazardous situation, which, if not avoided, could result in property damage.</p> |
| IMPORTANT | <p>IMPORTANT: used for installation, operation and maintenance information that are not related to safety.</p> |

SAFETY AND WARNINGS

Electrical Shock Hazard

Before removing a faulty oven light bulb, make sure you turn OFF the power to the range at the main fuse or circuit breaker panel. If you don't know how to do this, contact an electrician.

Do not remove the kick panel or the back panel. Due to electrical wires behind it, both panels should only be removed by a qualified technician.

This appliance is equipped with a three-prong grounding plug for your protection against shock hazard and should be plugged directly into a properly grounded power outlet. Do not under any circumstances cut or remove the grounding prong from this plug.

Failure to follow this advice may result in death or electrical shock.

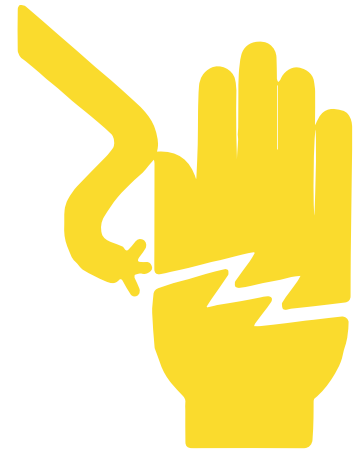

Tipping Hazard

All ranges can tip and cause injuries to adults and children. To prevent tipping, install the anti-tip device supplied with your range. Follow all installation instructions.

Even after the safety device is installed, do not step, lean or sit on the oven door or place any heavy objects on it. Doing so may result in personal injury.

Make sure anti-tip device is installed as follows:

1. Slide the range forward.
2. Install the anti-tip device as described in the instruction sheet
3. Safely tilt the front section of the range and slide the range slowly back against the wall.
4. The rear pins should slide under the bracket.

Do not use the appliance until it has been secured. Failure to follow this advice may result in serious injury.

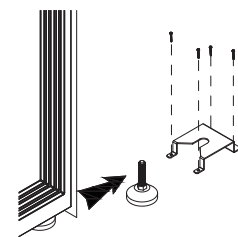
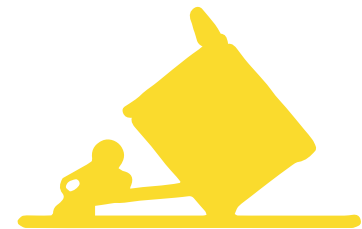

Anti-tip device for 30 inch

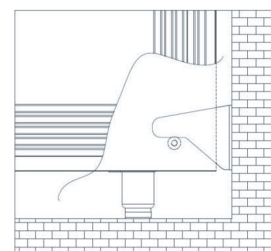

Anti-tip device for 36 inch

SAFETY AND WARNINGS

Explosion Hazard

If you smell gas, do not use the appliance. Open a window or door to let the gas escape, then follow the instructions on the inside front cover of this manual.

Do not use water on grease fires. A violent steam explosion may result.

Turn all burners off, then smother fire or flame with a dry chemical or foam-type extinguisher. Do not try to smother with blanket-blank.

Do not heat unopened food containers such as cans. Build-up of pressure may cause container to burst and result in injury.

Failure to follow this advice may result in injury or death

Fire Hazard

Never use your appliance as a space heater. Persons could be injured or a fire could start.

Keep the area around the appliance free from combustible materials (e.g. wall coverings, curtains, drapes), gasoline and other flammable vapors and liquids.

Clean the stove and burners regularly. Do not let cooking grease or other flammable materials accumulate on the surfaces or near the appliance.

Do not hang any articles (e.g. dish towels) off the oven handle. Some fabrics may ignite or melt from the heat.

Never leave the cook top burners unattended when in use. Boil over causes smoking and greasy spillovers that may ignite.

Never spray an aerosol cleaner on or around the appliance while burners are lit, Be sure all the controls are turned off and the appliance is cool. The aerosol gas and chemicals in such cleaners could, in the presence of heat, ignite or cause metal parts corrode.

Do not store flammables near cook top
Flammable materials should not be stored in an oven or near the cook top. An accident could cause a serious fire.



SAFETY AND WARNINGS

Poisoning Hazard

Never cover any slots, holes or passages in the oven bottom or cover an entire rack or the oven floor with materials such as aluminum foil. Doing so blocks airflow through the oven and may cause carbon monoxide poisoning. Aluminum foil linings may also trap heat, causing a fire hazard.

Clean the appliance with caution. If a wet sponge or cloth is used to wipe spills on a hot cooking area, be careful to avoid steam burn. Some cleaners can produce noxious fumes if applied to a hot surface. Follow the directions of the cleaner manufacturer.

Failure to follow this advice may result in poisoning or death.



Hot Surface Hazard

Accessible parts may become hot during use.

Do not touch burners, areas near burners, the grill, griddle, grease drip- pans, heating elements or interior surfaces of oven. These may be hot enough to cause burns even though they are dark in color. During and after use, do not touch, or let clothing or other flammable materials contact these parts and surfaces until they have had sufficient time to cool. Other parts and surfaces of the appliance may become enough to cause burns - among these areas are the grates, back trim and oven vents at the back of the cook top, front edge, surfaces adjacent to the cook top, and the oven door.

Use only dry potholders. Moist or damp potholders on hot surfaces may result in burns from steam. Do not let potholder touch hot heating elements. Do not use a towel or other bulky-cloth.

Let hot grease cool before attempting to handle it. Failure to follow this advice could result in burns and scalds.



Other Safety Tips

- ✓ Read instructions before use
Read all the instructions before using appliance. Use the appliance only for its intended purpose as described in constructionist.
- ✓ Install the stove properly
Be sure your stove is properly installed and grounded by a qualified technician.

SAFETY AND WARNINGS

- ✓ Do not install or operate stove if damaged. Do not operate the appliance if it is damaged or not working properly. If you received a damaged product, contact your dealer or installer immediately.
- ✓ Know how to turn off power in emergency. Be sure to have the installer show you where and how to turn off the power supply to the range (i.e. location of the main fuse or circuit breaker panel) and where and how to turn off the gas supply to the range in an emergency.
- ✓ Do not leave children alone near stove
Children should not be left alone or unattended in the area where the appliance is in use. They should never be allowed to play with the appliance or to sit or stand on any part of the appliance.
- ✓ Do not store toys or candy over the stove
For safety reasons, do not store items of interest to children in cabinets above a range or at the back of the range – children climbing on the range to reach items could be seriously injured.
- ✓ Don't wear loose clothing that could catch fire
Loose-fitting or hanging garments should never be worn while using the appliance.
- ✓ Do not repair or replace parts yourself (unless recommended) Do not repair or replace any part of the appliance unless specifically recommended in the manual. All other servicing should be referred to a qualified technician. Technicians must disconnect the appliance from the power supply before any servicing.
- ✓ Careful opening oven door
Use care when opening the oven door by allowing warm air or steam escape before removing or replacing food.
- ✓ Keep oven vent ducts unobstructed.
- ✓ Do not touch hot oven shelves
Protect your hands from burning by making sure the oven is cool before sliding oven shelves into oven. If a shelf must be removed while the oven is hot, do not let oven mitts or potholder contact the base of the oven or hot heating elements in the oven.
- ✓ Protect oven gasket
Do not clean the oven gasket or use any oven-cleaning products on it. It is essential for a good seal,
- ✓ which ensures that the oven operates efficiently. Care should be taken not to rub, damage or move it.
- ✓ Protect glass oven doors
Do not use harsh/abrasive cleaners, scourers or sharp metal scrapers to clean the oven door glass since they scratch the surface, which may result in the glass shattering.
- ✓ Never step on oven door or place a heavy object (like a Turkey) on it
- ✓ Check for gas leaks
When the appliance is installed, check for gas leaks according to the instruction before use.
- ✓ Ventilation hood is mandatory
This appliance should not be operated without a properly sized and operational ventilation hood.
- ✓ Use proper gas conversion kit
This stove might be used for natural gas or liquid propane. If you are not sure whether the unit is used for NG or LP, please contact your dealer or Thor customer service for verification. For LP conversion, please use conversion kit for your certain model. Please have a certified technician install the unit and kit (technical support is available during normal business hours). If planning to resell unit, please indicate whether it is natural gas or has LP kit installed.
- ✓ Do not reach for items over the stove when it is lit Be careful when reaching for items stored in cabinets above the appliance.
- ✓ Read all instructions before using the product to ensure proper and safe operation. Install or locate the product only in accordance with the provided Installation Instructions.
- ✓ Do not attempt to adjust, repair, service or replace any part of your appliance unless it is specifically recommended in this guide.
- ✓ Do not use the range as a space heater.
- ✓ Do not leave children unattended in the area where the range is in use. Never allow children to sit or stand on any part of the range. Do not let children play with the range.
- ✓ All servicing should be referred to a qualified technician.
- ✓ Have the technician show you the location of the gas shut off valve and how to shut it off in an emergency.

SAFETY AND WARNINGS

- ✓ Always disconnect power to appliance before any type of servicing.
- ✓ Do not use abrasive or caustic cleaners or detergents on this appliance. They may cause permanent damage to the surface.
- ✓ When cooking, set the burner controls so that the flame heats only the bottom of the utensil and does not overlap at the sides of the utensil.
- ✓ Utensils (pots and pans) that conduct heat slowly, i.e. glass pots, should be used in conjunction with burner flames at a low or medium setting.
- ✓ Turn off all controls and wait for appliance parts to cool down before touching them. Do not touch the burner grates or surrounding areas until cool.
- ✓ Do not use water on grease fires.
- ✓ Clean appliance with caution.
- ✓ Always turn pot handles to the side or back of the range. Do not turn handles towards the area where they are easily burned. Handles should not extend over the adjacent burners.
- ✓ Use the range only for cooking tasks as outlined in this manual. When using the range, do not touch the grates, burner caps, burner bases, or any other parts in proximity to the flame. These components may be hot enough to cause burns.
- ✓ Use dry pot holders. Moist or damp pot holders on hot surfaces may result in burns from steam.
- ✓ Do not use a towel or other bulky cloth.
- ✓ Do not heat unopened food containers. Buildup of pressure may cause the container to explode and result in injury.
- ✓ During and after use, do not touch intercommunicates of the oven until cool.
- ✓ Do not let pot holder touch hot subsurface.

GAS SUPPLY REQUIREMENTS

5. Gas Supply Requirements

Installation of this range must conform with local codes, or in the absence of local codes, with national Fuel Gas Code, ANSIZ223.1 / NFPA 54.

In Canada, installation must conform to the current natural Gas Installation /code, CAN 1-1.1-M81 and with local codes where applicable.

This range has been design-certified according to ANSIZ21.1a, latest edition.

| Reading | LP in. w.c. | NG (Natural Gas) in. w.c |
|---|-------------|--------------------------|
| Maximum gas pressure | 11.0 | 7.0 |
| Appliance Regulator Setting for outlet pressure | 10.0 | 5.0 |

Safety Tips for Gas Operation

- ✓ Keep appliance area clear and free from combustible materials, gasoline, and nonflammable vapors.
- ✓ Do not obstruct the flow of combustion air into the range and ventilation air away from the range.
- ✓ Ventilation: it is a must that the unit be set under a powered, vented exhaust hood of sufficient size and capacity.
- ✓ Before installing the range, you must locate and secure the included anti-tip bracket to the wall for your range.



- ✓ The use of cabinets for storage above the appliance may result in a potential burn hazard. Combustible items may ignite; metallic items may become hot and cause burns. If a cabinet storage is to be provided, the risk can be reduced by installing a range hood that projects horizontally a minimum of 5" (12.7cm) beyond the bottom of the cabinets.



WARNING

- ✓ The appliance shall not be used for space heating. This information is based on safety considerations.
- ✓ All openings in the wall behind the appliance and in the floor under the appliance shall be sealed.

6. Dimensions and Clearances

- ✓ The range may be installed flush to the rearwall.
- ✓ You may install a non-combustible material, such as tile, on the rear wall above the range and up the vent hood.
- ✓ It is not necessary to install non-combustible materials behind the range below the countertop height.
- ✓ The minimum distance from the side of the range above the counter top to combustible sidewalls must be at least 10 inches.

Btu Design

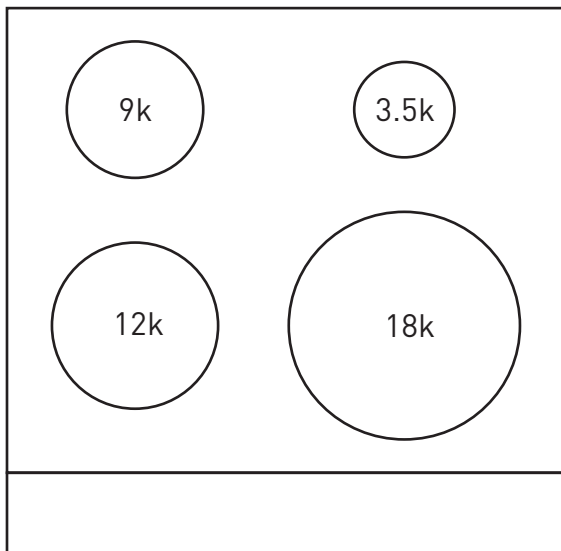

ARG30

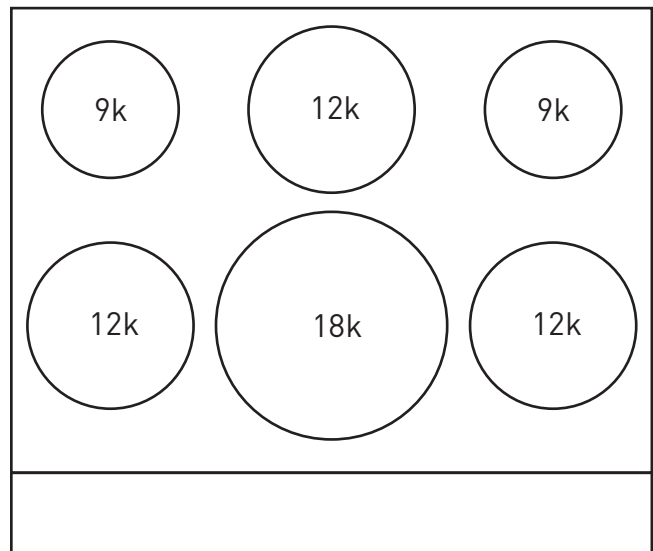

ARG36

DIMENSIONS AND CLEARANCE

Gas range dimensions

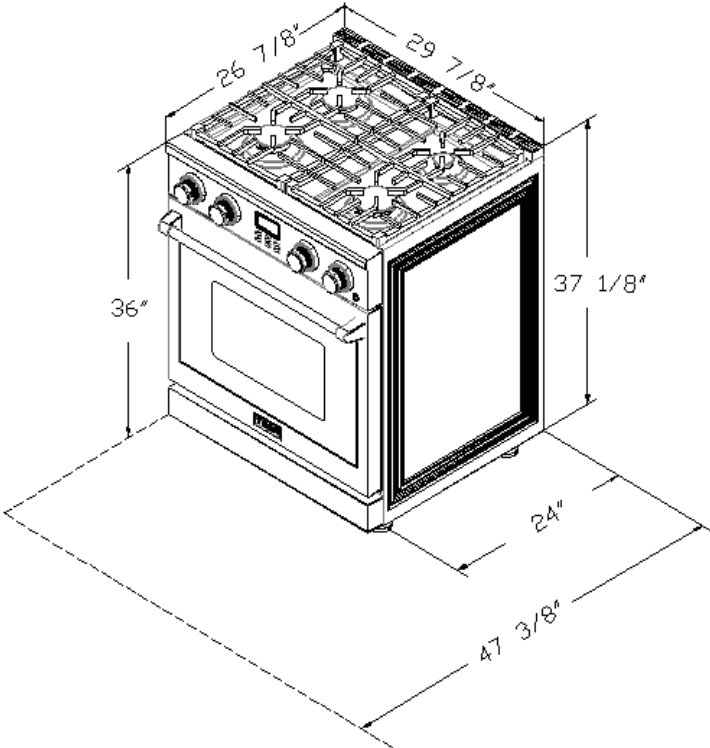

ARG30

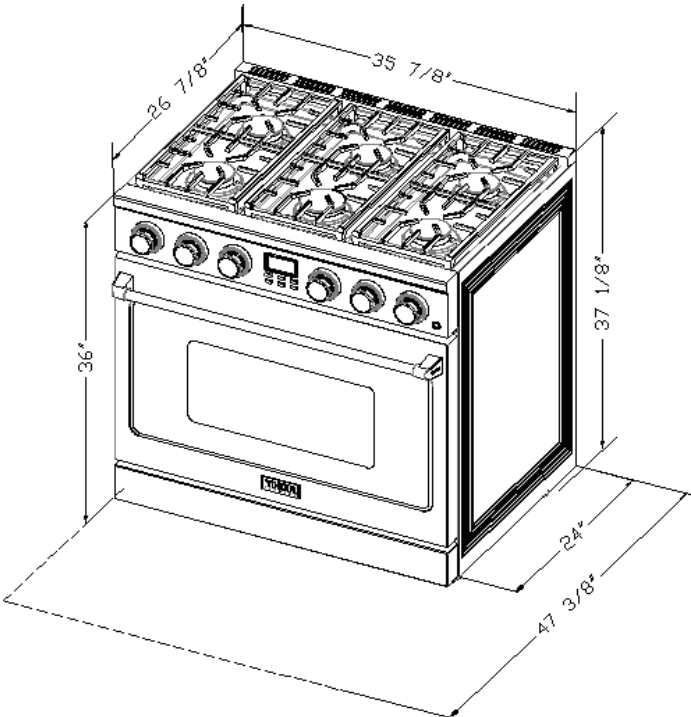

ARG36



DIMENSIONS AND CLEARANCE

Gas range clearance

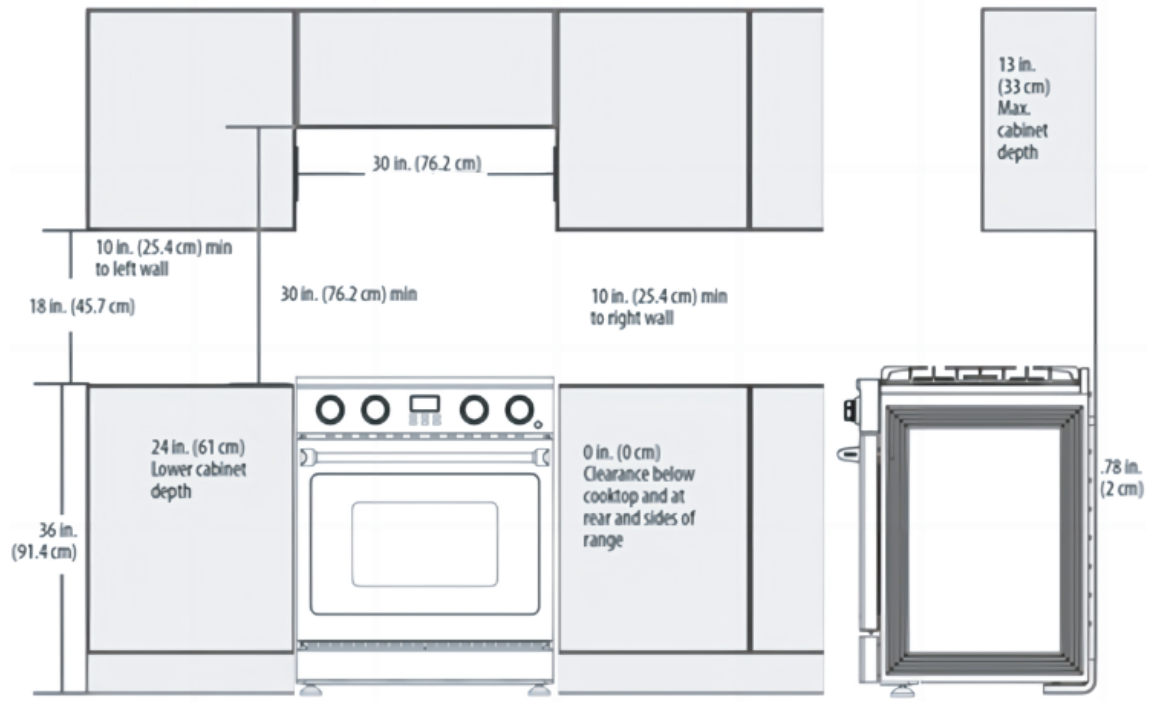

ARG30

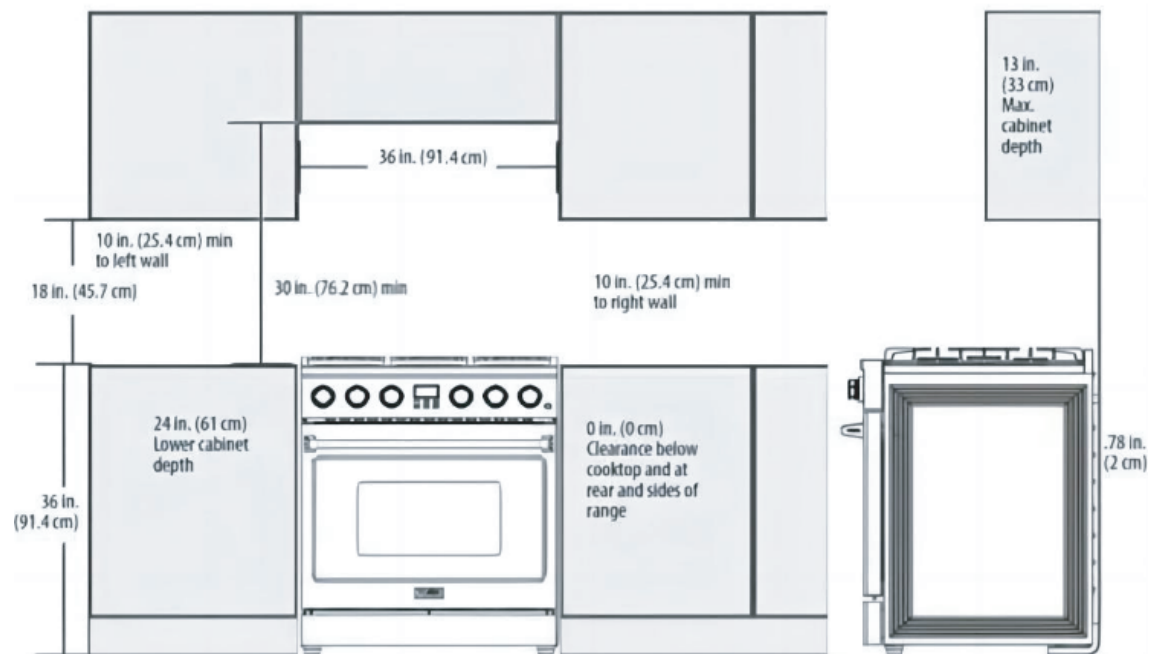

ARG36



ELECTRIC POWER SUPPLY REQUIREMENTS

7. Electric Power Supply Requirements

Your range must be electrically grounded in accordance with local codes or, in the absence of local codes, in accordance with the National Electrical Code (ANSI/NFPA 70, latest edition).

In Canada, electrical grounding must be in accordance with the current CSA C22.1 Canadian Electrical Code Part 1 and/or local codes. A copy of this standard may be obtained from: National Fire Protection Association, 1 Battery March Park, Quincy, Massachusetts 02269-9101.

The power supply must be the correct polarity. Reverse polarity will result in continuous sparking of the electrodes, even after flame ignition. If there is any doubt as to whether the power supply has the correct polarity or grounded, have it checked by a qualified electrician.

Use 120V, 60Hz, and properly grounded branch circuit protected by a 15-amp or 20-amp circuit.

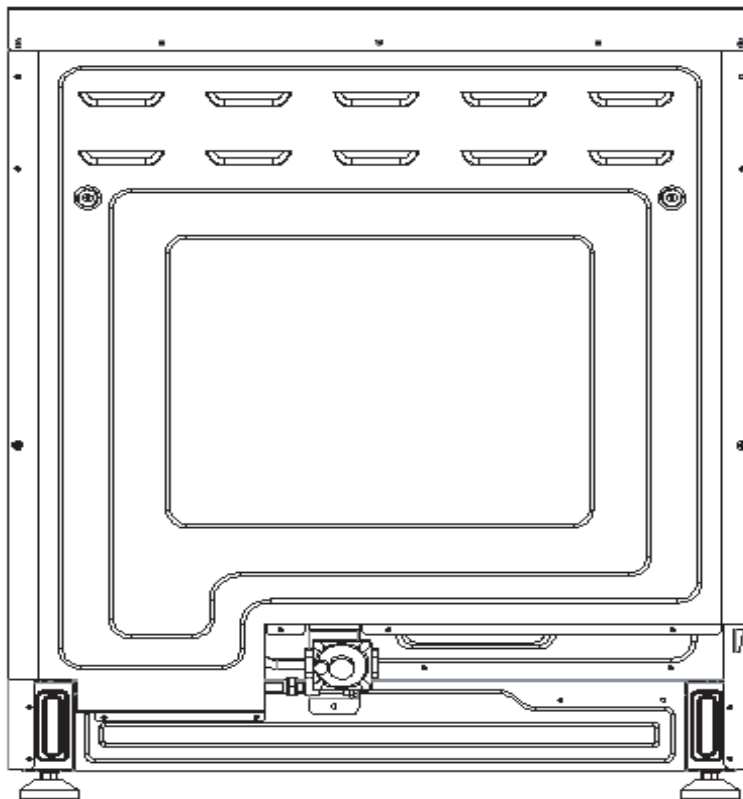

Installation for ARG Gas Range

ELECTRICAL GROUNDING INSTRUCTIONS

8. Electrical Grounding Instructions

WARNING

This indoor gas cooking appliance is equipped with a three-prong (grounding) plug for your protection against shock hazard and should be plugged directly into a properly grounded three- pronged receptacle.

Where a standard two-prong wall receptacle is encountered, it is the responsibility and litigation the customer to have it replaced with a properly grounded three-prong wall receptacle.

Do not cut or remove the grounding prong from the power cord.

Before connecting plug to the cord, disconnect the electrical supply.

CAUTION

Label all wires prior to disconnection when servicing controls. Wiring errors can cause improper and dangerous operation. Verify proper operation after servicing.

9. Connect Range to Gas Supply

Most localities will require that the stove shutoff valve and gas connections be installed by a certified technician or plumber. These instructions are for a professional. Gas installation specifications and regulations may vary so please consult your local codes before proceeding.

1. Install a manual gas line shut-off valve in the gas line as follows:

- a.** in an easily accessed location outside the range
- b.** in the gas piping external to the appliance

2. Install male 1/2" flare union adapter to 1/2" NPT internal thread elbow at inlet of regulator.

On models equipped with standard twin burners, install the male pipe thread end of the 1/2" flare union adapter to the 1/2" NPT internal thread at inlet of pressureregulator.

Use a wrench on the regulator fitting to avoid damage.

CONNECT RANGE TO GAS SUPPLY

Install male 1/2" or 3/4" (3/4" refers to 48-inch gas range) flare union adapter to the NPT internal thread of the manual shut-off valve, taking care to secure the shut-off valve to keep it from turning.

The gas supply pressure for checking the regulator setting is 6 in.w.c. (Nature Gas) and 11 inch.w.c. (LP gas) connect flexible gas line connector to the regulator on the range. Position range to permit connection at the shut-off valve.

When all connections have been made, make sure all range controls are in the position and turn on main gas supply valve.

Leak testing of the appliance shall be conducted according to the manufacturer's instructions. Use some soap water (50% water and 50% soap) or a leak detector at all joints and connections to check for leaks in the system. Do not use a flame to check for gas leaks.

The appliance must be isolated from the building's gas supply piping system by closing its individual manual shut-off valve during any pressure testing of the gas supply piping system at test pressure equal to or less than 1/2 pig (3.5kPa).

After installation:

Check ignition of cook top burners.

Check ignition of oven burner.

Visually check tubular burner (oven burner) re-ignition to be sure both rows of burner ports are relighting each time.

Check for gas leaks at all gas connections (using a gas detector, never a flame).

Check oven bake and convection bake function.

10. First Use

Conditioning the oven

Conditioning will burn off any manufacturing residues and ensure that you get the best results right from the start.

Follow these steps to condition your new stove's oven:

1. Insert all the shelves. See 'Positioning the shelves' for instructions.
2. Turn on the ventilation hood above your range on high.
3. Heat the empty oven at the highest temperature for:
 - a. 30 minutes using BAKE
 - b. 30 minutes using BROIL (some ovens only).
4. There will be a distinctive smell while you are conditioning the oven. This is normal, but make sure the kitchen is well ventilated during the conditioning.
5. Once cooled, wipe out the oven with a damp cloth and mild detergent, and dry thoroughly.
6. Positioning the shelves
7. Both the sides panel and shelves with safety stop to keep them sliding out of the oven when pulled forward;
8. And the front stop prevents the shelves from against hitting the back of the oven

11. Cooktop Safety Guidelines

There are dual burners have the same low turn-down setting (SIM) for gentle simmering (620 BTU/hr.). Use the SIM setting for melting chocolate and butter, cooking rice and delicate sauces, simmering soups and stews, and keeping cooked food hot.

- ✓ Never leave the cook top unattended when in use. Boil over causes smoking and greasy spills that may ignite.
- ✓ Never allow flames to extend beyond cookware or curl up on sides. This could discolor and damage the utensil and you may get burned touching the hot handle.

COOKTOP SAFETY GUIDELINES

Keep handles out of the way. Turn handles so that they don't extend over the edge of the range or on a burner that is on.

Take care when deep-frying. Oil or fat can overheat very quickly, particularly on a high setting.

Make sure that all burner parts are properly in place. Incorrectly or incompletely assembled burners may produce dangerous flames. See 'Replacing the burner parts' in 'Care and cleaning'.

Keep the burners clean, especially after a spill or boil over, make sure you clean the affected burners before using them again. Food residue may clog the igniter and the notches of the flame spreader, stopping the burner from functioning correctly. See "Care and cleaning" for instructions.

Check that the burner flames. They should be blue with no yellow tipping, and burn without fluttering all around the burner cap. If not, see 'Troubleshooting' for advice.



Surface Burner Ignition

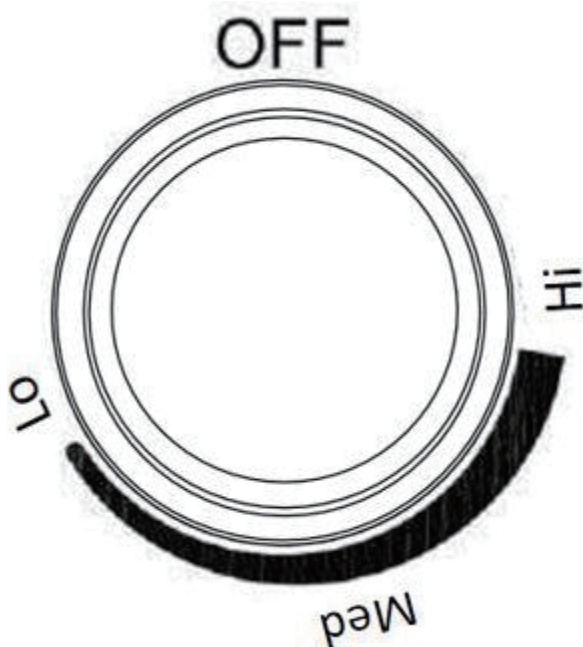

To light the top burners, push and turn the appropriate control knob counter clockwise to the "Hi" or "Med" or "Lo" position. You will hear a clicking noise – the sound of the electric spark igniting the burner. Once burner ignition has been achieved, then turn the burner control knob to adjust the desired heat setting.

COOKTOP SAFETY GUIDELINES

NOTE: When one burner is turned to the “Hi” position, the burner igniters will park. Do not attempt to disassemble or clean around any burner while another burner is on. Do not touch any burner cap, burner base, or ignite while the igniters are sparking.

Simmer and Boil

A smaller flame will give the best simmer results. Small flames offer precise cooking performance for delicate foods, keeping food warm, melting chocolate or butter, and for cooking that need to cook over low heat for a long time.

The highest flame settings provides the maximum heat that is available on your range. This setting should be used for heavy cooking loads such as water boiling or pastacooking.

Flame Size

When you select the flame size, watch the flame when you turn the knob.

Any flame larger than the bottom of the cookware is wasted. The flame should be steady and blue in color. Foreign material in the gas line may cause an orange flame during initial operation.

Power Failure

If the gas does not ignite within four seconds, turn off the valve and allow at least five minutes for any gas to dissipate. Repeat the lighting procedure.

If the power fails, it is not capable of being safely placed in operation and user that no attempt should be made to operate during power failure.

Cooktop

To prevent the cooktop from discoloring or staining, clean cooktop after each use, and wipe up acidic or sugary spills as soon as the cooktop has cooled.

The sealed burners of your range are not sealed to your cooktop and are designed to be removed. Boil overs or spills will not seep underneath the cooktop. The burners should be cleaned after each use.

COOKTOP SAFETY GUIDELINES

Burner Grates

The grates must be properly positioned before cooking. Improper installation of the grates may result in scratching of the cooktop and / or poor combustion.

- ✓ Do not place water, ice, or any dish or tray directly on the oven floor, as this will irreversibly damage the enamel.
- ✓ Do not cover the slotted grid of the broil/roast pan with aluminum foil. This will catch the grease and could cause fire.
- ✓ Do not use plastic wrap or wax paper in the oven.
- ✓ For food safety reasons, do not leave food in the oven for longer than two hours before and after cooking or defrosting. This is to avoid contamination by organisms which may cause food poisoning. Take care during warmer weather.

WARNING

NEVER use this appliance as a space heater to heat or warm the room. Doing so may result in carbon monoxide poisoning and overheating of the oven.

12. Operating The Oven

Oven Cooking Safety Guidelines

- ✓ Do not block the ducts on the rear of the range when cooking in the oven. It is important that the flow of moist warm air from the oven and fresh air into the oven burner never be interrupted.
- ✓ Avoid touching the vent opening or nearby surfaces during oven or broiler operation because they are hot. Do not place plastics, paper or other items that could melt or burn near the oven vent.
- ✓ Use all the oven modes with the oven door closed.
- ✓ Never use aluminum foil to cover the oven shelves or to line the floor of the oven. The trapped heat can irreversibly damage the enamel and may even cause a fire.
- ✓ Do not place water, ice, or any dish or tray directly on the oven floor, as this will irreversibly damage the enamel.
- ✓ Do not cover the slotted grid of the broil/roast pan with aluminum foil. This will catch the grease and could cause fire.
- ✓ Do not use plastic wrap or wax paper in the oven.
- ✓ For food safety reasons, do not leave food in the oven for longer than two hours before and after cooking or defrosting. This is to avoid contamination by organisms which may cause food poisoning. Take care during warmer weather.

WARNING

According to the United States Department of Agriculture: DO NOT hold foods at temperatures between 40°F to 140°F more than 2 hours. Cooking raw foods below 275°F is not recommended.

WARNING

NEVER cover any slots, holes or passages in the oven bottom or Cover an entire rack with materials such as aluminum foil. Doing so blocks airflow through the oven and may cause carbon monoxide Poisoning. Aluminum foil linings may also trap heat, causing a fire hazard.

OPERATING THE OVEN

Oven Function

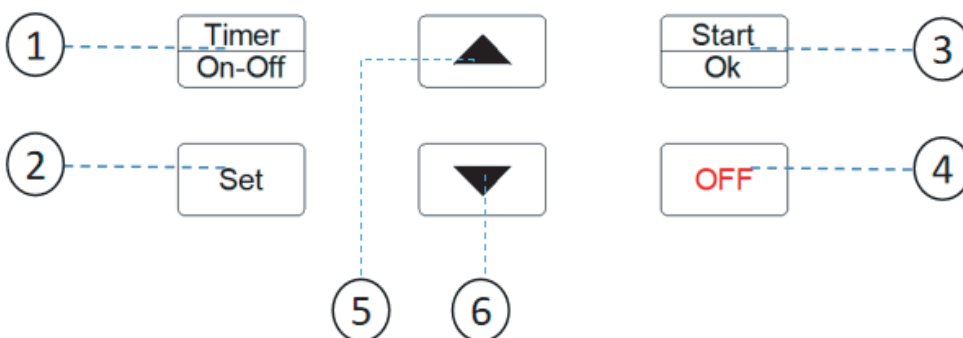

1. Timer On-Off: Set or cancel the kitchen timer;
2. Set: Using option settings;
3. Start/OK: start oven cooking and confirm when setting;
4. **OFF**: Exit or return to reset and exit work;
5. Up button: Set options or move up or number to increase up;
6. Down button: Set options to move down or number to decrease;

Using the option function

This function enables you to control various electronic control options. Refer to the following table for available options. The option menu is only available when the oven is not being used (not cooking).

| Options | Feature |
|-------------------------|---|
| 1.Clock | You can set the clock |
| 2.Temp Unit | Lets you program the oven control to display temperatures in Fahrenheit or Centigrade. |
| 3.Sound On/Off | Lets you set the oven controls to operate silently. |
| 4.Temp Calibration | Lets you correct the temperature in the oven. |
| 5.12 hrs Safety Shutoff | This feature automatically turns off the oven after 12 hours during baking functions or after 3 hours during a broil function. |

OPERATING THE OVEN

Clock

Using Clock, you can set the oven clock display. How to turn the clock:

1. Press "Set", and then press "Start/OK" or Press ▲ or ▼ to select CLO
2. Press ▲ or ▼ to set the clock.
3. Press "Start/OK" to save the changes.

Temp Unit

Using Temp Unit, you can switch the temperature units you want. How to turn temp unit:

1. Press ▲ or ▼ to select "F-C", and then press "Start/OK"
2. Press ▲ or ▼ to select "°F" or "°C"
3. Press "Start/OK" to save the changes.

Sound On/Off

Using Sound On/Off, you can set the oven controls to operate silently. How to turn Sound On/Off:

1. Press ▲ or ▼ to select "Son", and then press "Start/OK"
2. Press ▲ or ▼ to select "ON" or "OFF"
3. Press "Start/OK" to save the changes.

Temp Calibration

The temperature in the oven has been calibrated at the factory. When first using the oven, be sure to follow recipe times and temperatures. If you think the oven is too hot or too cool, you can correct the temperature in the oven. Before correcting, test a recipe by using a temperature setting that is higher or lower than the recommended temperature. The baking results should help you to decide how much of an adjustment is needed.

The oven temperature can be adjusted ± 30 °F. How to correct the oven temperature:

1. Press ▲ or ▼ to select "CAL" and then press "Start/OK"
2. Press ▲ or ▼ to select you want number,
3. Press "Start/OK" to save the changes.

NOTE:

This adjustment will not affect the broiling or the self-cleaning temperatures. The adjustment will be retained in memory after a power failure.

12 hrs Safety Shutoff

If you accidentally leave the oven on, this feature will automatically turn off the oven after 12-hours during baking functions or after 3 hours during a broil function. **(Default setting : ON)** How to use the 12 hrs Safety Shutoff :

1. Press ▲ or ▼ to select "SAF" and then press "Start/OK".

OPERATING THE OVEN

2. Press ▲ or ▼ to select "On" or "Off".
3. Press "Start/OK" to save the changes.

Cooking Modes Bake

The oven can be programmed to bake at any temperature from 175 °F to 550 °F. Baking temperature and time will vary depending on the ingredients and the size and shape of the baking pan used. Dark or nonstick coatings may cook faster with more browning.

How to set the oven for baking:

1. Press ▲ or ▼ to select "Bake", and then press "Start/OK".
2. Press ▲ or ▼ to select the desired temperature, and then press "Start/OK".
3. Displays cooking time Settings, you can press ▲ or ▼ to select you want cooking time.
4. Press "Start/OK" to save the changes, or do not set cooktime directly press "Start/OK" and then the oven will work on the maximum safe time, The temperature display will start to change once the oven temperature reaches 100 °F (the actual oven temperature is displayed when the remaining oven temperature is between 100°F than 550°F).
5. If you want to change the cooking time or cooking mode, Press "OFF" to stop the oven and return to the cooking mode selection.
6. When the cooking time arrives, the oven will stop working and the buzzer will sound, and the display screen will switch to "End" for the cooking time. If the oven door is not opened within 1 minute and the "End" will go out, return to the standby state display (standby state will show the clock, and when the temperature in the oven \cong 150°F will show "HOT").

NOTE

Place food in the oven after preheating if the recipe calls for it. Preheating is very important for good results when baking cakes, cookies, pastry, and breads. After the oven has reached the desired temperature, the range will beep.

Conv Bake

The oven convection fan circulates and distributes the heat in the oven for faster and even cooking. Convection cooking allows you to bake more items on multiple racks.

To bake using the convection fan:

1. Position the oven bottom cover and the oven shelves before using oven.
2. Remove any unused shelves and baking utensils from the oven.
3. Preheat the oven to the temperature stated in the recipe. Depending on the temperature and the size of the oven, preheating will take around 15-20 minutes.
4. Arrange pans and food items evenly on the shelves. Make sure pans do not touch each other or the sides of the oven. When baking a single item, always center the item on the oven shelf. If baking on multiple shelves, make sure you stagger items on the shelves so that one is never directly above another.
5. When baking using convection, either reduce the temperature stated in the recipe and leave the baking time unchanged, or reduce the baking time by several minutes and leave the temperature unchanged. For foods with a baking time of over an hour, reducing both the temperature and time slightly may give the best results.
6. Dark metal baking pans or those with a dull finish absorb heat faster than shiny pans, and are excellent for pies and breads, or anything that needs browning or a crisper crust.
7. A shiny finish may work best for foods that require lighter, delicate browning (e.g. cakes and

OPERATING THE OVEN

cookies), as it reflects some heat and gives a less intense baking surface.
8. Avoid opening the oven door frequently during baking.

How to set the oven for convection bake:

1. Press ▲ or ▼ to select "Conv Bake", and then press "Start/OK".
2. Press ▲ or ▼ to select the desired temperature, and then press "Start/OK".
3. Displays cooking time Settings, you can press ▲ or ▼ to select you want cooking time.
4. Press "Start/OK" to save the changes, or do not set cooktime directly press "Start/OK" and then the oven will work on the maximum safe time, The temperature display will start to change once the oven temperature reaches 100 °F (the actual oven temperature is displayed when the remaining oven temperature is between 100°F than 550°F).
5. If you want to change the cooking time or cooking mode, Press "OFF" to stop the oven and return to the cooking mode selection.
6. When the cooking time arrives, the oven will stop working and the buzzer will sound, and the display screen will switch to "End" for the cooking time. If the oven door is not opened within 1 minute and the "End" will go out, return to the standby state display (standby state will show the clock, and when the temperature in the oven \cong 150°F will show "HOT").

Conv Roast

For best results use the broiler pan. The pan is used to catch grease spills and has a cover to prevent grease splatter.

The convection fan circulates heated air over the around the food being roasted, sealing juices quickly for a moist and tender product while, at the same time, creating a rich golden-brown exterior.

Use the broil/roast pan and slotted grid supplied with the range when roasting in order to elevate the meat on a metal roasting rack. This allows hot air to circulate around the meat, browning it more evenly like a rotisserie. A suitable roasting rack can be purchased through by the distribute or Customer Care.

When roasting larger items like a whole turkey, use only the pan and grid for greater stability.
How to set the oven for convection roast:

1. Press ▲ or ▼ to select "Conv Roast", and then press "Start/OK".
2. Press ▲ or ▼ to select the desired temperature, and then press "Start/OK".
3. Displays cooking time Settings, you can press ▲ or ▼ to select you want cooking time.
4. Press "Start/OK" to save the changes, or do not set cooktime directly press "Start/OK" and then the oven will work on the maximum safe time, The temperature display will start to change once the oven temperature reaches 100 °F (the actual oven temperature is displayed when the remaining oven temperature is between 100°F than 550°F).
5. If you want to change the cooking time or cooking mode, Press "OFF" to stop the oven and return to the cooking mode selection.
6. When the cooking time arrives, the oven will stop working and the buzzer will sound, and the display screen will switch to "End" for the cooking time. If the oven door is not opened within 1 minute and the "End" will go out, return to the standby state display (standby state will show the clock, and when the temperature in the oven \cong 150°F will show "HOT").

Pizza

The oven can be programmed to bake at any temperature from 175 °F to 550 °F. Baking temperature

OPERATING THE OVEN

and time will vary depending on the ingredients and the size and shape of the baking pan used. Dark or nonstick coatings may cook faster with more browning.

How to set the oven for pizza:

1. Press ▲ or ▼ to select "Pizza", and then press "Start/OK"
2. Press ▲ or ▼ to select the desired temperature, and then press "Start/OK"
3. Displays cooking time Settings, you can press ▲ or ▼ to select you want cooking time.
4. Press "Start/OK" to save the changes, or do not set cooktime directly press "Start/OK" and then the oven will work on the maximum safe time, The temperature display will start to change once the oven temperature reaches 100 °F (the actual oven temperature is displayed when the remaining oven temperature is between 100°F than 550°F).
5. If you want to change the cooking time or cooking mode, Press "OFF" to stop the oven and return to the cooking mode selection.
6. When the cooking time arrives, the oven will stop working and the buzzer will sound, and the display screen will switch to "End" for the cooking time. If the oven door is not opened within 1 minute and the "End" will go out, return to the standby state display (standby state will show the clock, and when the temperature in the oven $\geq 150^{\circ}\text{F}$ will show "HOT").

Warm

When cooking is finished, Keep Warm will hold the food at a safe serving temperature for up to 3 hours. After 3 hours, the feature will shut off automatically. You can use the keep warm feature without any other cooking operations, or you can set it to activate after a timed or delay timed cooking operation. You should not use this feature to reheat cold food. How to set the oven for warm:

1. Press ▲ or ▼ to select "Warm," and then press "Start/OK", Displays the default temperature but cannot be set.
2. You can press ▲ or ▼ to select you want cooking time.
3. Press "Start/OK" to save the changes, or do not set cooktime directly press "Start/OK" and then the oven will work on the maximum safe time.
4. If you want to change the cooking time or cooking mode, Press "OFF" to stop the oven and return to the cooking mode selection.
5. When the cooking time arrives, the oven will stop working and the buzzer will sound, and the display screen will switch to "End" for the cooking time. If the oven door is not opened within 1 minute and the "End" will go out, return to the standby state display (standby state will show the clock, and when the temperature in the oven $\geq 150^{\circ}\text{F}$ will show "HOT").

Broil

Broiling is a method of cooking tender cuts of meat by direct heat under the broil element of the oven. The high heat cooks quickly and gives a rich, brown outer appearance. Broil mode is best for meats, fish, and poultry up to 1" thick.

Always preheat the oven for 5-10 minutes before broiling.

How to set the oven for broiling:

1. Press ▲ or ▼ to select "Broil," and then press "Start/OK".
2. You can press ▲ or ▼ to select "Hi" or "Lo".
3. Press "Start/OK" to save the changes, and then the oven will work on the maximum safe time.
4. If you want to cancel broiling or change the cooking mode, Please press "OFF" to reset.

13. Cleaning Instructions

Do's

- ✓ Read these cleaning instructions and the 'Safety and warnings' section before you start cleaning your range.
- ✓ Before cleaning or removing any part, make sure that everything on the range has been turned off.
- ✓ Unless suggested otherwise in the following chart, allow any part to cool to a safe temperature before cleaning. If you do need to handle a warm or hot part (e.g. grill or griddle), take extreme care. Wear long protective mitts to avoid burns from steam or hot surfaces.
- ✓ Try using any cleaner on a small area first, to ensure it does not stain.
- ✓ See the pages following this chart for instructions on removing and replacing various parts of the range for cleaning or maintenance.
- ✓ To help you identify any parts, see illustrations in section 'Introduction' and after this cleaning chart.

Don'ts

- ✓ Do not use aerosol cleaners until the range has completely cooled. The propellant substance in these cleaners could catch fire in the presence of heat.
- ✓ Do not let soiling or grease accumulate anywhere in or on the range. This will make future cleaning more difficult and may present a fire hazard.
- ✓ Do not use any abrasive or harsh cleaners, cloths, scouring pads or steel wool. These will scratch your range and damage its appearance.
- ✓ Do not use a steam cleaner to clean any part of the range.
- ✓ Do not lift the black grill and griddle frames off the cooktop.

Cleaning Burner caps and flame spreaders

1. Check that the burner is turned OFF and allow it to cool. Lift off the burner cap and flame spreader. Wash them in hot soapy water, rinse, and dry.
2. Use a stiff nylon brush or straight-ended paper clip to clear the notches of a flame spreader. Replace the flame spreader and burner cap correctly.
3. Before cleaning the cooktop, ensure that all burners are turned off and that all components are cool enough to safely touch.
4. To avoid electrical shock or burns, turn off controls and ensure the cooktop is cool before cleaning.

CLEANING INSTRUCTIONS

5. Do not use harsh or abrasive cleaning detergents, waxes, polishes, or commercial cooktop cleaners to clean the cooktop.
6. Use only a sponge, soft cloth, fibrous or plastic brush, and nylon pad for cleaning.
7. Always dry components completely before using the cooktop.
8. Control Panel, Door Handle, Control Housing

Clean the control panel, door handle and control housing with a solution of mild detergent and warm water.

9. Do not use abrasive cleaners or scrubbers; they may permanently damage the finish.
10. Dry the components with a soft, lint-free cloth.

Cleaning oven shelves

1. To remove stubborn or 'baked-on' soiling, scrub with a dampened, soap-filled, non-metal, non-abrasive pad, then wipe dry.
2. Apply a chrome cleaner with a damp sponge or cloth following manufacturer's instructions.
3. Wipe and dry.

Cleaning broil/roast pan

- ✓ Pre-soak any stubborn soiling in a solution of mild detergent and hot water.
- ✓ Wash by hand or in a dishwasher.

Cleaning bake and broil burners

- ✓ Do not clean these parts. They self-clean during normal use.

Cleaning porcelain surfaces

- ✓ Clean oven interior and inner door liners with a solution of mild detergents and hot water. Rinse and dry with a soft, lint-free cloth. Do not use abrasives or commercial oven cleaners.

Cleaning the oven glass window

- ✓ Clean all glass surfaces with a solution of mild detergent and hot water. Use a mild glass cleaner to remove fingerprint or smears.
- ✓ Dry completely with a soft, lint-free cloth.

CLEANING INSTRUCTIONS

Cleaning the oven door gasket

Avoid cleaning this part. If you need to remove large food particles off it, proceed as follows:

1. Dampen a sponge with clean hot water.
2. Gently wipe off the soiling, but do not rub.
3. Press a dry towel gently on the gasket to dry.

Do not use any cleaning detergents on the gasket. The gasket is essential for a good seal.

CAUTION: Do not scratch, displace, or damage it.

Cleaning stainless steel surfaces

Do not use any cleaning product with chlorine bleach.

Do not use a steel wool pad; it will scratch the surface.

Use a hot, damp cloth with a mild detergent.

Use a clean, hot, damp cloth to remove soap. Dry with a dry, clean cloth.

REMOVING AND REPLACING THE OVEN DOOR

14. Removing and replacing the oven door

Do not lift the oven door by its handle. Doing so may damage the door.
Make sure the oven and the door are cool before you begin to remove the door.

IMPORTANT

Before removing the door, make sure there is a large enough clear, protected surface in the kitchen to rest the door on.

The oven door is heavy!

Removing the oven door

1. Open the door very carefully

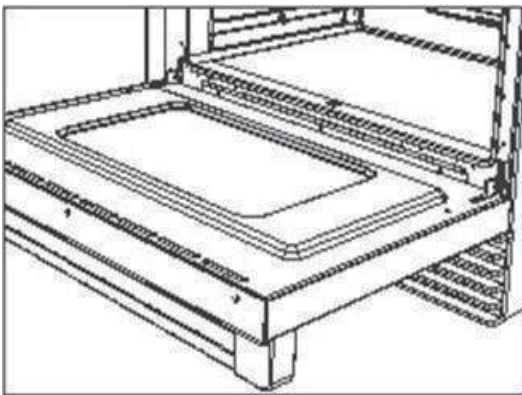

3. Holding the door firmly on both sides.

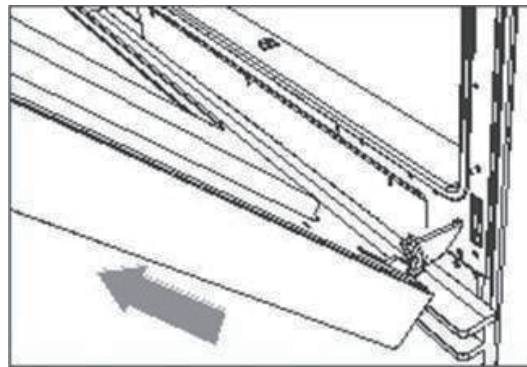

2. Open the levers fully on both sides.

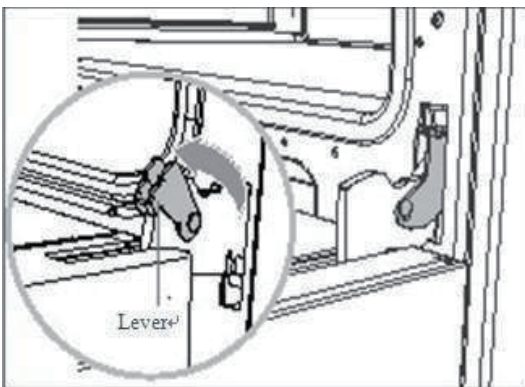

4. Disengage the hinges and remove the door, place on a protected surface.

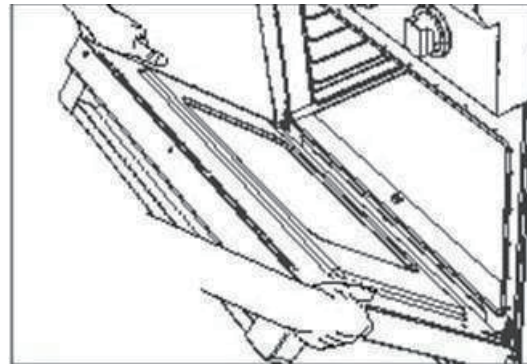

REMOVING AND REPLACING THE OVEN DOOR

Replacing the oven door

1. Hold the door firmly in an approximately open position.

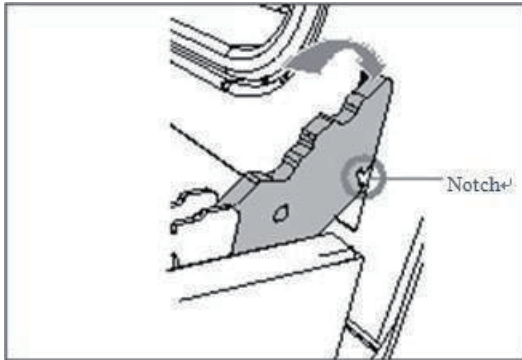

2. Insert the hinge tongues into the slots making sure that the notches on both sides drop into place as shown.

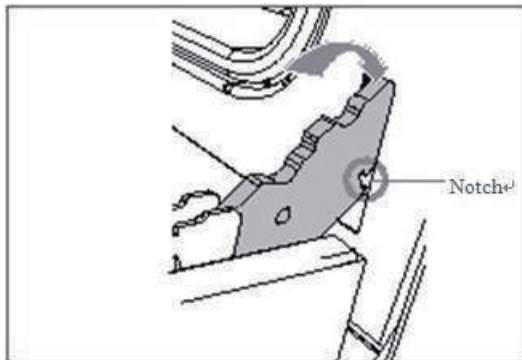

3. Open the door fully as shown,

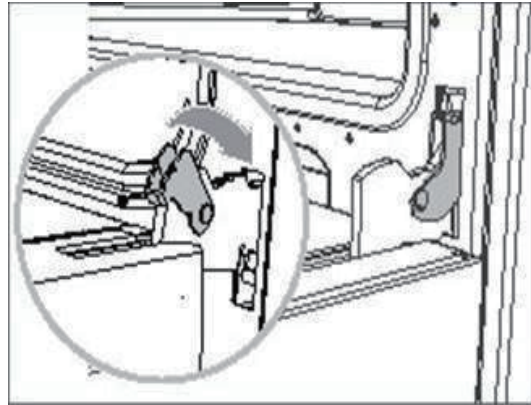

4. Fully close the levers on the left and right hinges, as shown, then close the door.

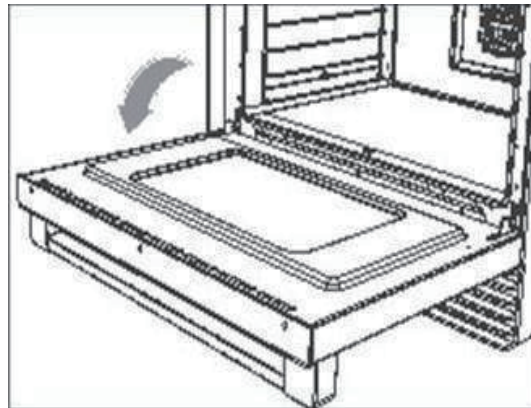

TROUBLESHOOTING GUIDE

15. Troubleshooting Guide

If you can't find an answer to your problem in the chart below, or if the problem cannot be fixed, you will need technical help. Contact your Authorized Service Center or Customer Care.

| Problem | Probable Causes | What To Do |
|---|--|---|
| COOKTOP | | |
| Some burners will not light. Flames do not burn all around the burner cap. | Burner parts or igniters may be wet, dirty, or misaligned. | Check that the burner parts are clean, dry, and correctly assembled. Check that the igniters are clean and dry. See 'Care and cleaning' for instructions. |
| Burner flames very large and yellow. | Burner bezel ports are clogged. Burner ports or burner caps are not positioned properly. Cooktop is being operated with the wrong type of gas. Regulator is not installed, is faulty, or is set for the wrong type of gas. | Clean burner bezel ring ports with straightened paper clip, needle, or wire. Remove and carefully re-install burner bezel and caps. Ensure that the type of cooktop matches the natural gas supply. Check installation, replace regulator, or set regulator for proper gas. |
| Sparking but no flame ignition. | Gas shut-off valve is in the 'OFF' position. | Turn shut-off valve to the 'ON' position. |
| Igniters spark continuously after flame ignition. | Power supply polarity is reversed. Igniters are wet or dirty. | Have polarity corrected. Dry or clean igniters. |
| Burner flame goes out at low setting. | Low gas supply pressure. Air intake holes around knobs are obstructed. | Contact gas company. Remove obstruction. |

| | | |
|--|---|---|
| <p>The flames have suddenly gone out.</p> | <p>A draft or a spill has extinguished the flame.</p> | <p>No action required. The burner will detect this and automatically relight. However,</p> <p>if there has been a large spill, we recommend turning the burners off and cleaning the burners and sump area. See 'Care and cleaning' for instructions</p> |
| <p>There is a power failure – can I still use the cooktop burners?</p> | <p>Power outage in your area.</p> | <p>The cooktop burners can still be used. To light them:</p> <p>Holding a lighted match to the flame spreader, push in on the control knob and turn counterclockwise to LITE.</p> <p>When the flame is burning all the way around the burner, you may adjust the heat. Important!</p> <p>If the flame is blown out during a power failure, turn the knob immediately to OFF, as the burner will not automatically relight and gas may escape.</p> |



TROUBLESHOOTING GUIDE

| Problem | Probable Causes | What To Do |
|---|--|---|
| OVEN | | |
| The oven doesn't work (no heating). | No power supply (oven light and halos do not come on either). No gas supply (gas ovens). | Check that the circuit breaker hasn't tripped and there is no power outage in your area. If there is a power outage, you cannot use the oven until power has been restored. The supply to the house may not be working or there may be an outage. Contact your local gas supplier. |
| One of the oven lights does not come on, but the oven works. | The light bulb is loose. The light bulb has blown. | See instructions for 'Replacing the oven light bulb' in section 'Care and cleaning'. Instead of replacing the bulb, simply ensure that it is secure in its socket. Replace the bulb. See instructions for 'Replacing the oven light bulb' in section 'Care and cleaning.' |
| Condensation around oven (e.g. on control panel or top of oven door.) | Food has high moisture content or local climate (temperature, humidity) is contributing to condensation. | Condensation is normal. You can wipe the drops off the control panel. If there is frequent or excessive condensation, make sure that cabinetry around the range is moisture-proofed. |
| Steam coming from oven vents at the back of the range. | Moisture from food evaporating during cooking. | This is normal, especially if you are cooking large quantities of food in the oven using a CONVECTION mode. |
| The convection fan does not come on in a CONVECTION mode. | Technical fault. | Contact your Authorized Service Center or Customer Care. |

TROUBLESHOOTING GUIDE

| | | |
|--|---|--|
| Oven will not heat | Oven settings are not corrected. | Follow mode selection and clock settings as specified in Oven Operation section of the manual. |
| Foods over-cooked or under-cooked. | Incorrect cooking time or temperature. | Adjust time, temperature, or rack position. |
| “Cracking” or “Popping” sound. | This is the sound of metal heating and cooling. | This is normal. |
| There is a power failure – can I still use the oven? | Power outage in your home or neighborhood. | The oven cannot be used until power is restored. |

Information code

| Error Code | Error Description |
|------------|---|
| E0 | The oven temperature control NTC is faulty |
| E1 | Overtemperature detection NTC faults |
| E2 | The circuit board NTC is faulty |
| E3 | The oven is not heated |
| E5 | The oven's not normal cooking temperature exceeds 343°C |
| E6 | The oven is not heated, but the temperature inside the oven |
| E9 | The clock malfunction |
| E10 | Chip fault |
| E15 | Circuit board overtemperature |
| E17 | Hall off the heat dissipation fan is faulty |

NOTE

Press **OFF**, then restart the oven. If the problem persists, disconnect all power to your range for at least 30 seconds, then reconnect the power. If this does not solve the problem, call for service.

WARRANTY

16. Warranty&Service

This product has been manufactured by Thor Group, 4651 E Airport Drive, California 91761

For Customer Service, please call (877) 288 - 8099

For the most up to date warranty and service policy, please refer to our website WWW.THORKITCHEN.COM/WARRANTY-REGISTRATION

For in-warranty service requests, please visit our website at WWW.THORKITCHEN.COM/SERVICE

Please Note: You must provide proof of purchase or installation date for any in-warranty service requests

Rubber Pad Installation on Back Panel

In order to meet the requirement for the clearance for the back of you Thor Kitchen Range, please install 2 pcs Rubber Pad provided in the manual package Please find the accessories and follow the below steps:

1. check the installation kit included in the manual package;

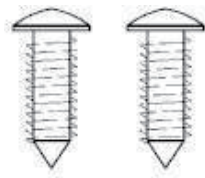

2* screws

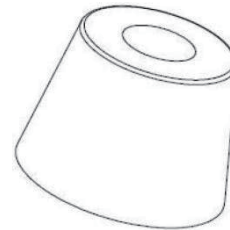

2* rubber pad

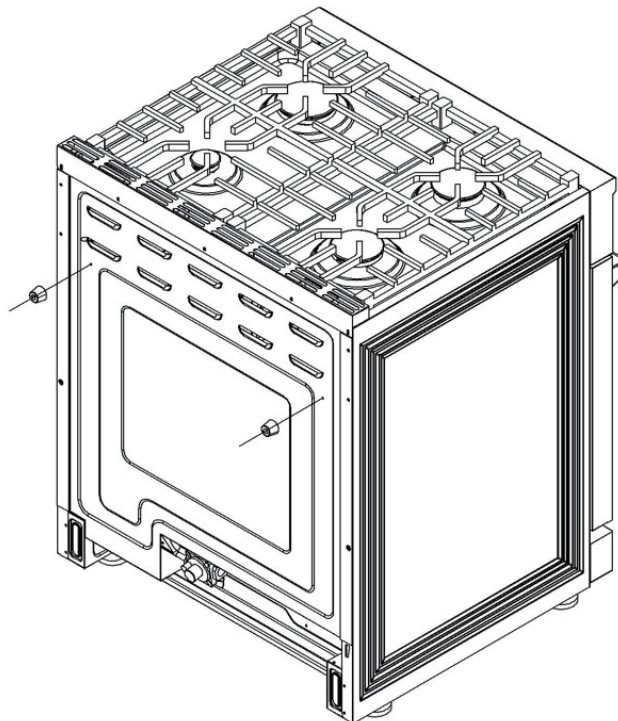

2. Install 2 pcs rubber pad shown above

WELCOME TO THE CLUB

You chose THOR Kitchen to enhance your culinary journey and we're stoked to have you in the club. Think of it as a secret society of really savvy people, such as yourself, choosing professional power and performance at an affordable price.



Register your product by following the steps below.

WARRANTY REGISTRATION



Scan the QR code or visit
thorkitchen.com/warranty



Input your product info
and select register



You're done.
Let's get cookin'.

WARRANTY



NEED PARTS?

